

CH-ST53-U12

[Chain ST53-U] Steel Standard Link Clock Chain

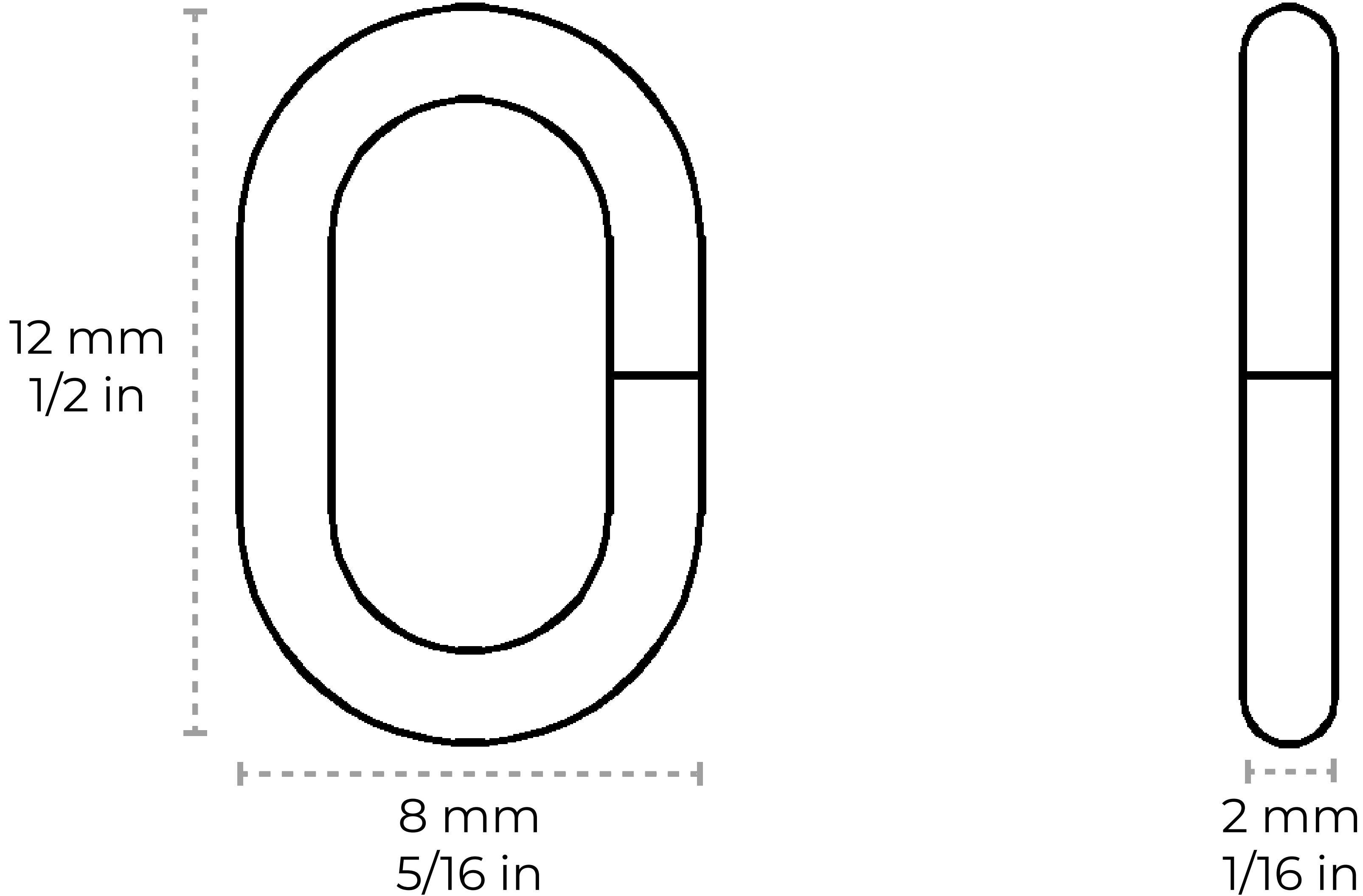

Material	Steel
Welding Type	Unwelded
Max Load	26 lbs
Weight per Foot	0.06 lbs/ft
Main Link Measurements	Length: 12 mm 1/2 in Width: 8 mm 5/16 in Diameter: 2 mm 1/16 in

Contact:

1-360-392-8121
<https://www.rchhardware.com>

