

NOTICE

- * Please make sure that you have all parts indicated and they are in good condition before you begin assembly of this item. Refer to part list and hardware list below for guidance.
- * This item should be assembled on a soft surface to prevent scratching the finish during assembly.
- * This item may require periodic tightening.
- * If you having difficulty, our friendly Customer Care team is always here to help.













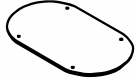

PREPARATION

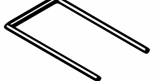
- * Before beginning assembly of product, make sure all parts are present. Compare parts with part contents list and hardware contents list.
- * If any part is missing or damaged, do not attempt to assemble the product.
- * Estimated Assembly Time: 30 minutes.
- * Tools Required for Assembly (included): Allen Key

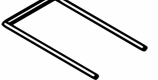
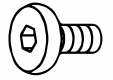
CARE AND MAINTENANCE

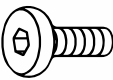
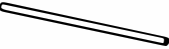
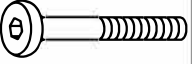
Always use felt pads under all articles to prevent discoloration or softening of the lacquer. Plastic and rubber bases on items can discolor wood. Wipe up spills immediately and avoid common hazards such as hot dishes, harsh solvents and abrasives. Cleaning should be done with a soft lint free cotton cloth dampened with water or furniture polish. On highly used surfaces we recommend applying a quality paste wax which should be used on a regular basis to provide additional protection from scratches and spills. How often you apply the wax depends on how much wear the furniture receives.

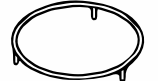
Part List and Hardware List

PIECE	DESCRIPTION	PICTURE	QUANTITY	PIECE	DESCRIPTION	PICTURE	QUANTITY
A	Table Top		1X	J	Supporter		1X
B	Bottom Board		1X	K	Support Tube		1X
C	Shelf Board		1X	HW1	Allen Key		1X
D	L-Side Frame		1X	HW2	Hex Bolt 1/4" x 1.2mm x 38mm		8X
E	R-Side Frame		1X	HW3	Hex Bolt 1/4" x 1.2mm x 12mm		9X
F	Leg		4X	HW4	Hex Bolt 1/4" x 1.2mm x 25mm		3X
G	Cross Tube		2X	HW5	Hex Bolt 1/4" x 1.2mm x 90mm		4X
H	Wine Glass Rack		1X	HW6	Washer		4X
I	Shelf Frame		1X	HW7	Cap		4X

Product Dimension: 29.5" x 17.7" x 32.8"H

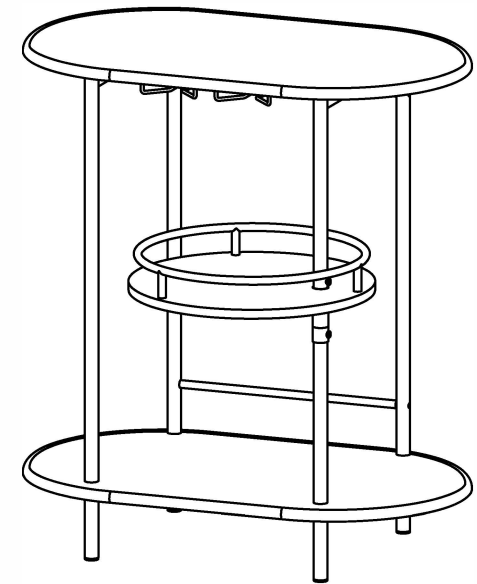

WARNING

Weight Capacity - 33.07LBS for table /
17.64LBS for shelf

Warning : Do not stand on table.

Warning : Do not over torque bolts.

PREPARATION

- * Before beginning assembly of product, make sure all parts are present. Compare parts with part contents list and hardware contents list.
- * If any part is missing or damaged, do not attempt to assemble the product.
- * Estimated Assembly Time: 30 minutes.
- * Tools Required for Assembly (included): Allen Key
- * If you having difficulty, our friendly Customer Care team is always here to help.

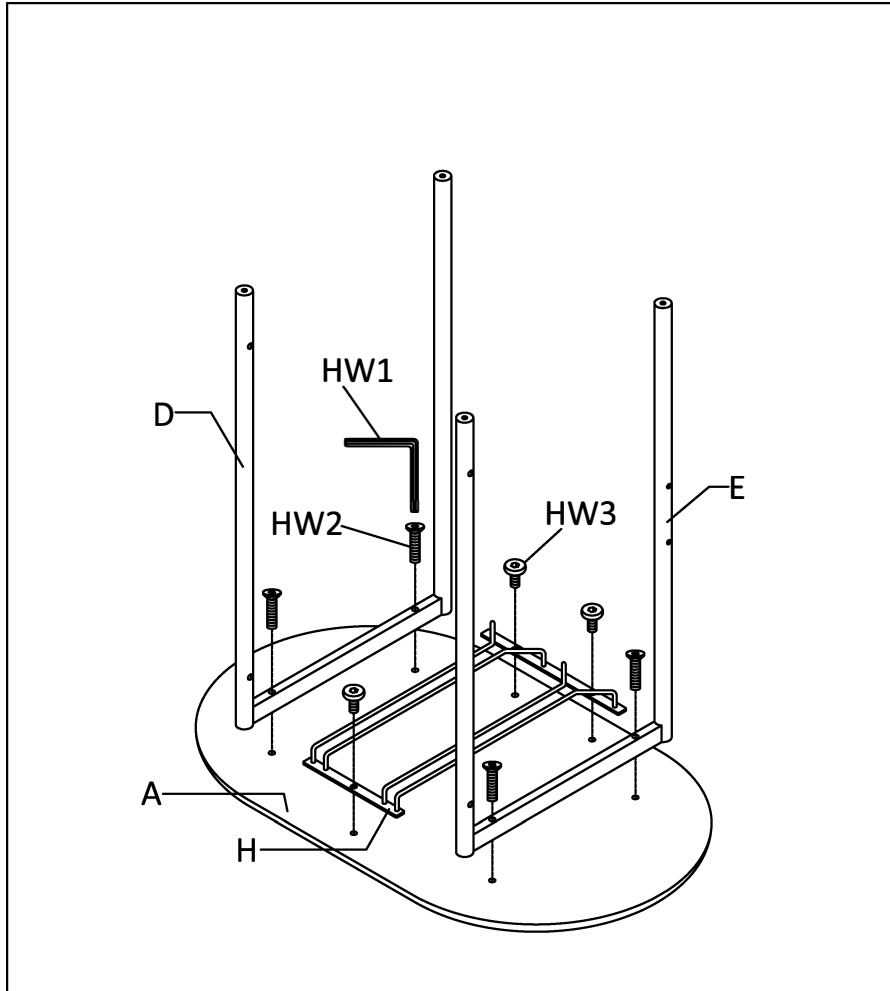

STEP1:

Please use the carton as a working surface to prevent table-top damage during assembly.

Assemble table top (A) and side frame (D,E) with bolt (HW2) by use of Allen key (HW1), then assemble table top (A) and rack (H) with bolt (HW3) by use of Allen key (HW1) as shown in drawing.

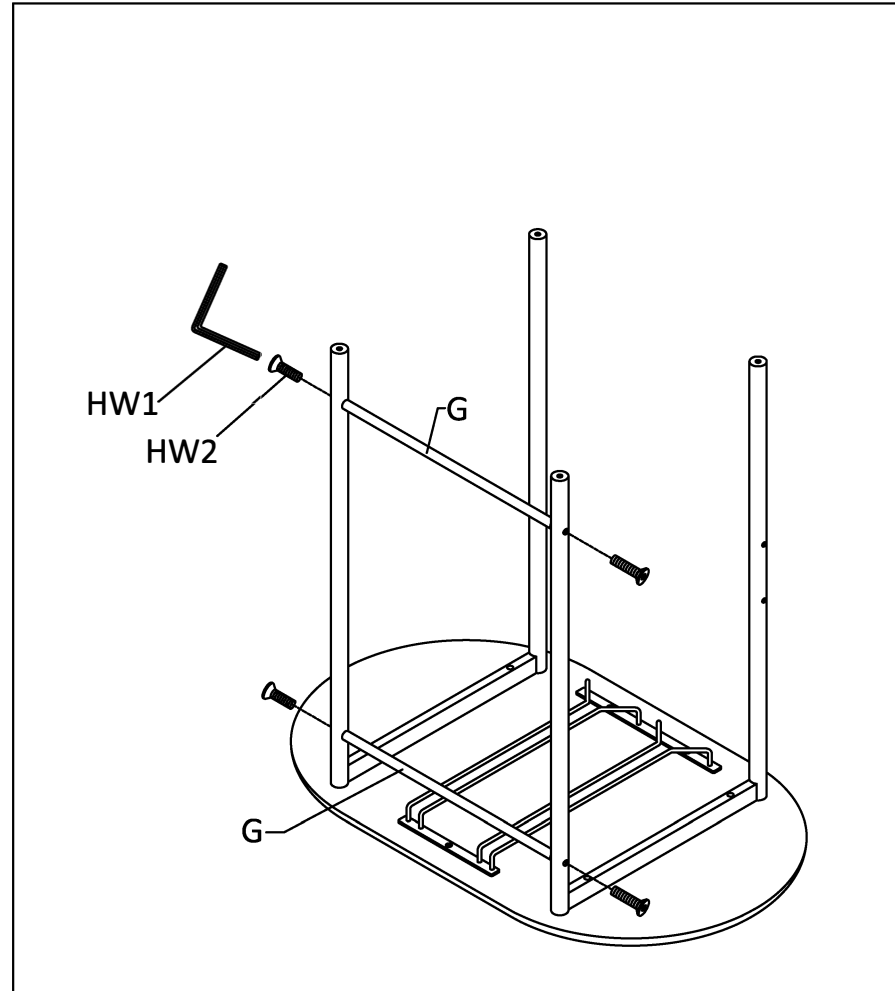

STEP2:

Assemble cross tube (G) on the assembled parts with bolt (HW2) by use of Allen key (HW1) as shown in drawing.

PREPARATION

- * Before beginning assembly of product, make sure all parts are present. Compare parts with part contents list and hardware contents list.
- * If any part is missing or damaged, do not attempt to assemble the product.
- * Estimated Assembly Time: 30 minutes.
- * Tools Required for Assembly (included): Allen Key
- * If you having difficulty, our friendly Customer Care team is always here to help.

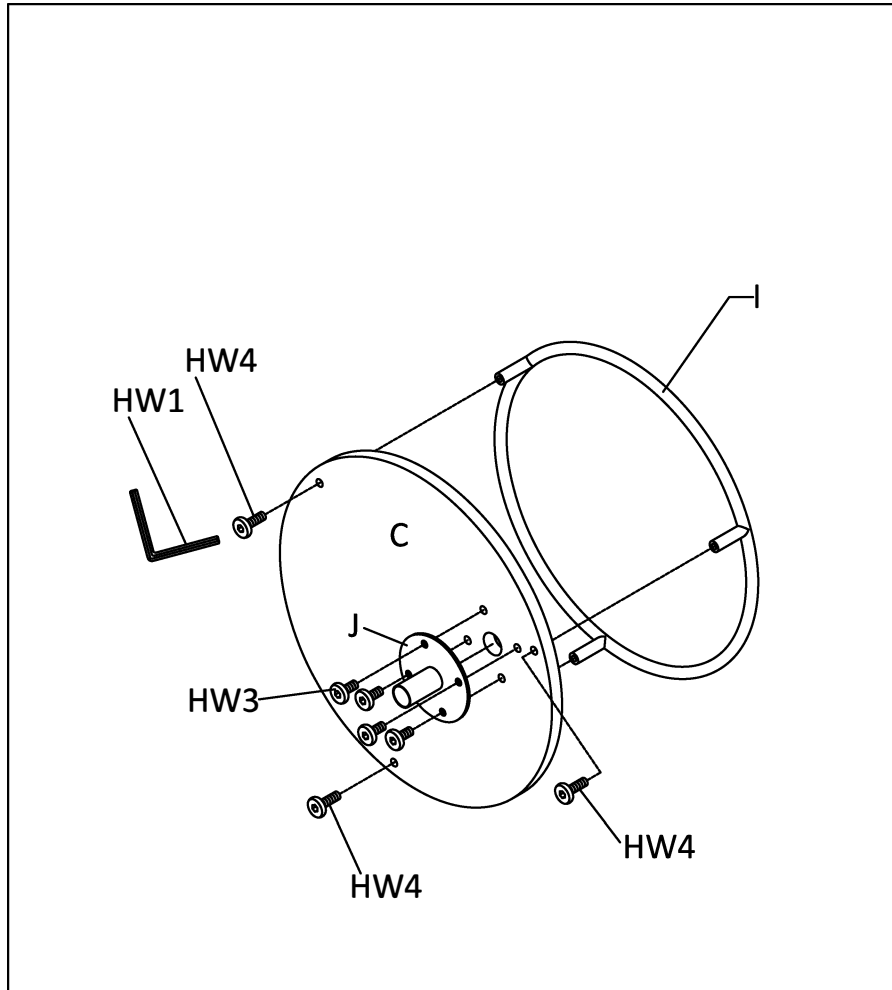

STEP3:
Assemble shelf board (C) and supporter (J) with bolt (HW3) by use of Allen key (HW1), then assemble shelf board (C) and shelf frame (I) with bolt (HW4) by use of Allen key (HW1) as shown in drawing.

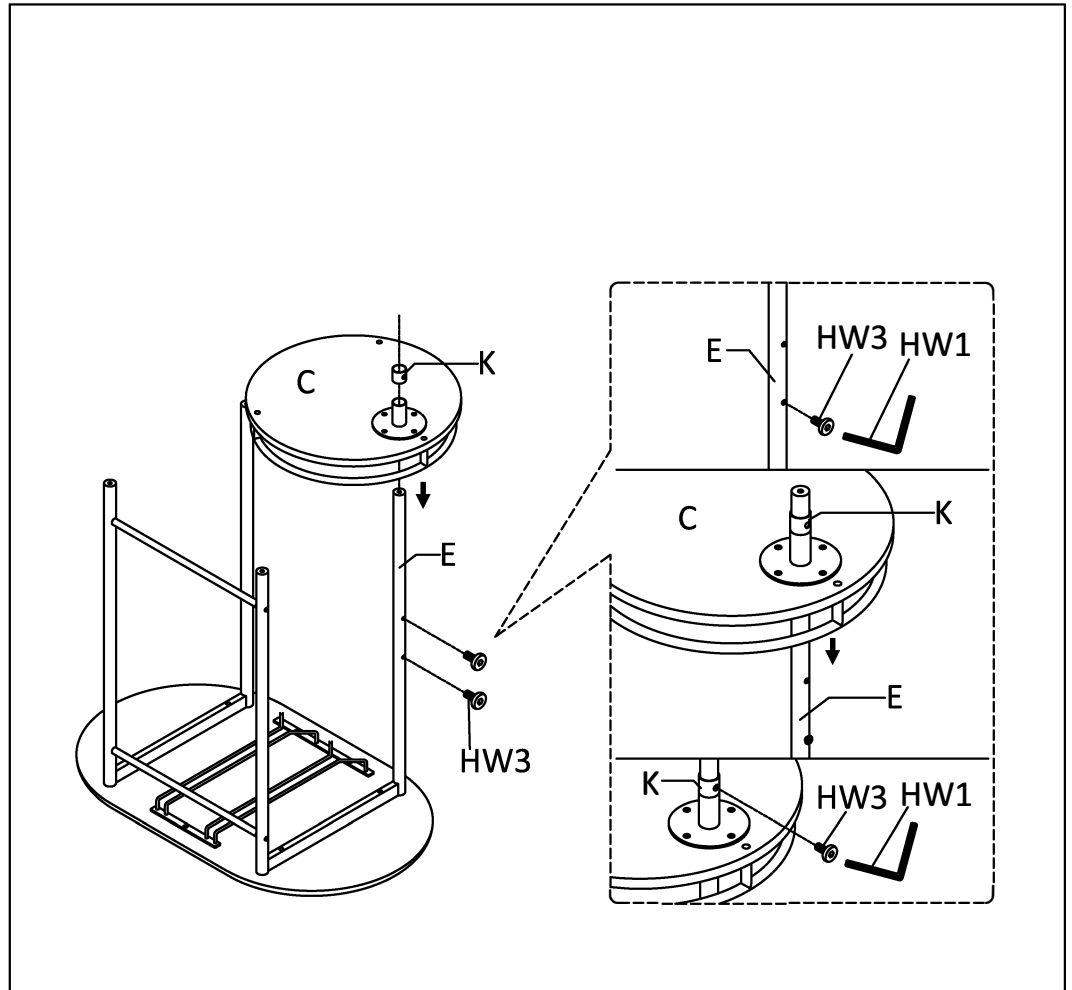

STEP4:
Tighten a bolt (HW3) into the bottom hole on the right side frame (E). Insert the assembled shelf (C&I&J) and support tube (K) into the leg of right side frame (E), then assemble the support tube (K) on right side frame (E) with bolt (HW3) by use of Allen key (HW1) as shown in drawing.

PREPARATION

- * Before beginning assembly of product, make sure all parts are present. Compare parts with part contents list and hardware contents list.
- * If any part is missing or damaged, do not attempt to assemble the product.
- * Estimated Assembly Time: 30 minutes.
- * Tools Required for Assembly (included): Allen Key
- * If you having difficulty, our friendly Customer Care team is always here to help.

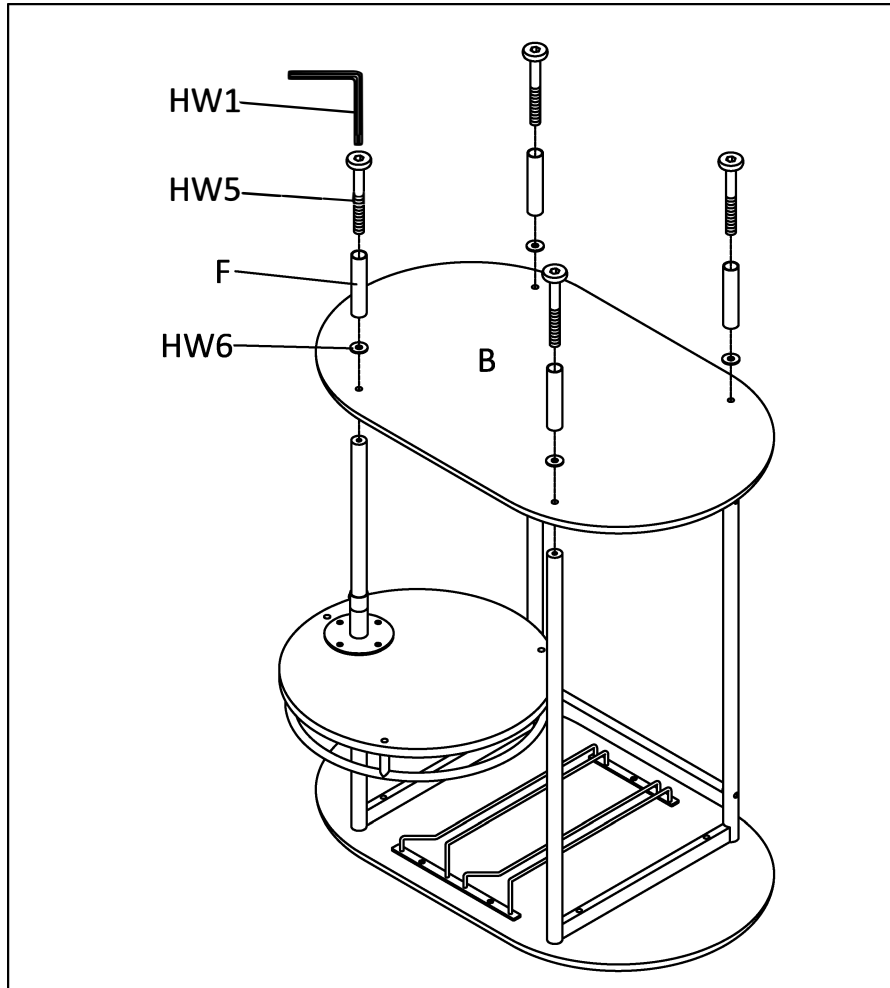

STEP5:

Assemble bottom board (B) and leg (F) on the assembled parts with bolt (HW5) and washer (HW6) by use of Allen key (HW1) as shown in drawing.

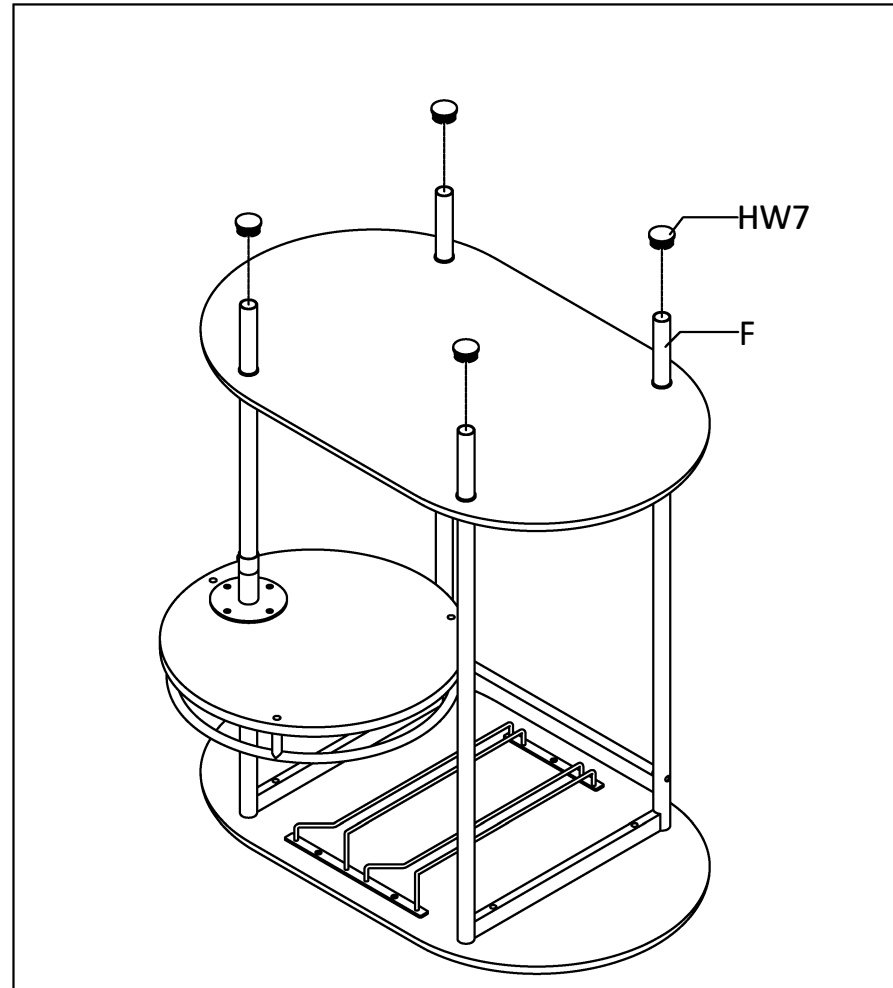

STEP6:

Make sure all bolts are fully tightened, then insert cap (HW7) into the tube end of bottom leg (F) as shown in drawing.