

Assembly Instructions

Caution: You must read this before you proceed

Dining Chair

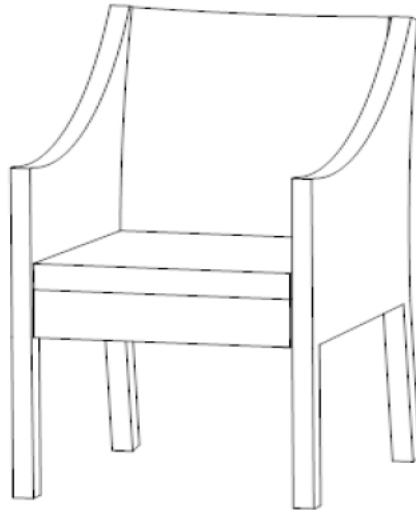

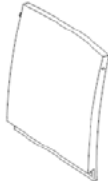
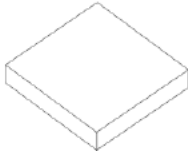

Parts List

Label	Picture	Description	QTY
A	A line drawing of the left armrest, showing a curved top and a vertical support leg.	Left Armrest	1
B	A line drawing of the right armrest, showing a curved top and a vertical support leg.	Right Armrest	1
C	A line drawing of the seat, showing a rectangular shape with a slightly raised edge.	Seat	1

D		Backrest	1
E		Seat Cushion	1

Hardware

Label	Picture	Description	QTY
①		Bolt (M6*35MM)	10
②		Washer	10
③		Allen Key	1

Assembly Preparation

Before Beginning Assembly:

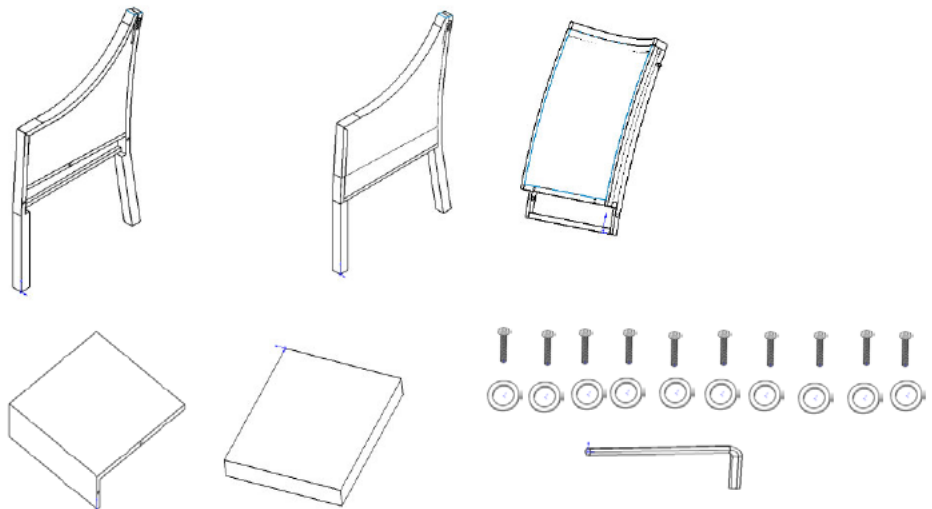

- Read instructions, cover to cover-



- Have 2 adults on hand for assembly-



- Do not assemble on flooring or carpet-



- Assemble on a clean non-marring surface (packing foam)-



- Save all packaging until finished-

Assembly Steps

Overview

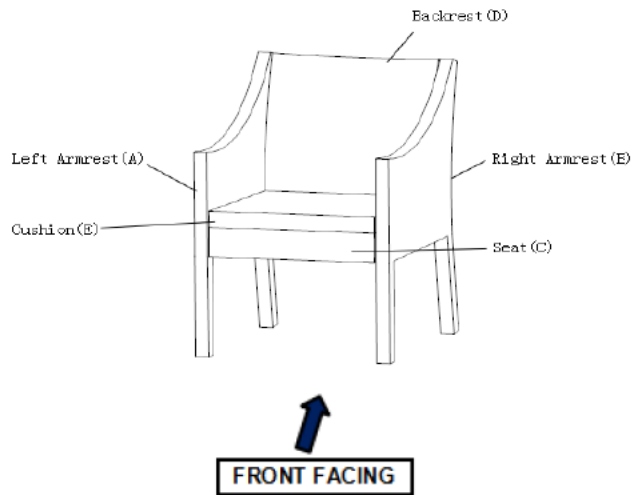

This Dining Chair has multiple parts and may require up to 30 minutes to assemble. To give you an overview of the Dining Chair parts, the above picture is to help you put the various parts into perspective. Please read through the instructions below to familiarise yourself with the parts and steps before assembly.

Step 1

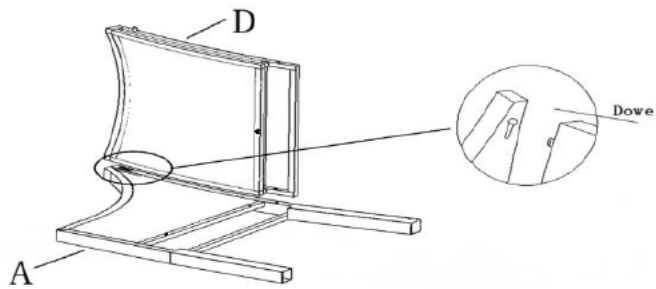
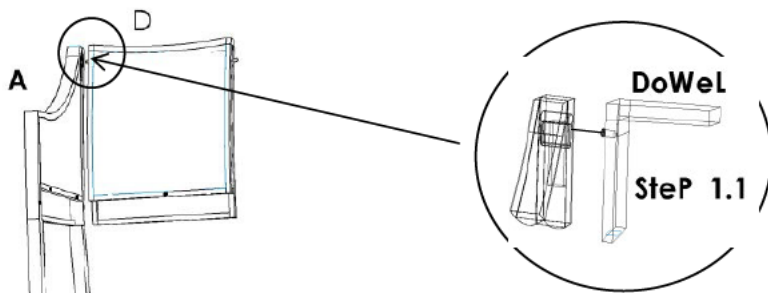

If the Dowel does not match the mounting position, please loosen the Dowel by 3-5MM.

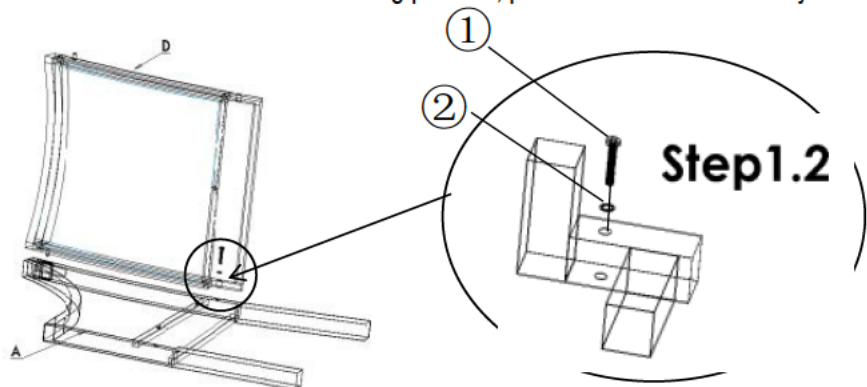

Open the carton and place all the parts onto a clean, non-marring surface.

1.1 Insert the Dowel on the Backrest(D) into the mounting position of the Left Armrest(A).

1.2 Attach Backrest(D) to Left Armrest(A) using Bolts(①) and Washers(②) with Allen Key(③) as shown in the picture.

Do not fully tighten the Bolts.

Occasionally some of the PE Wicker shifts and covers the mounting positions preventing easy assembly. The PE Wicker should never be cut, but moved away from the mounting positions.

Step 2

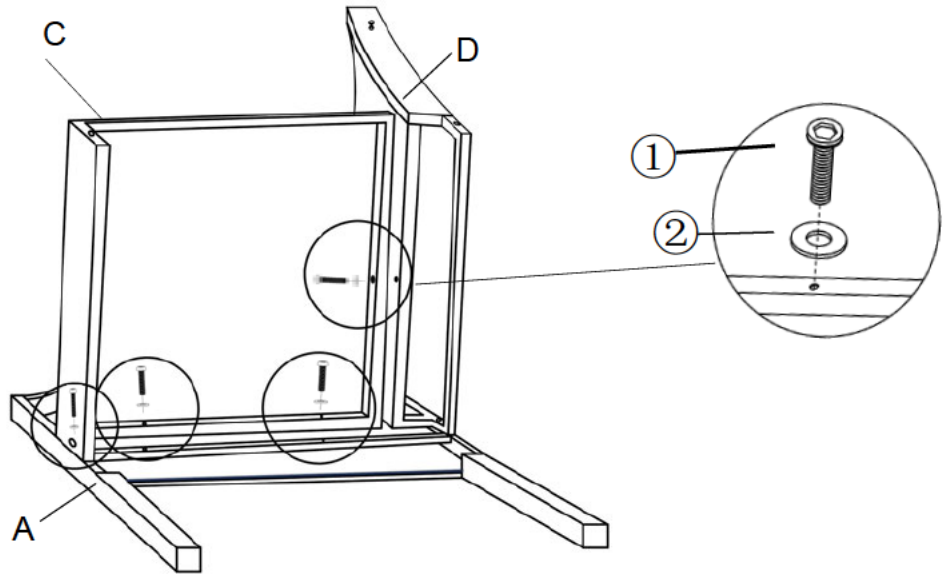

2.1 Align Seat(C) with Left Armrest(A) and Backrest(D).

2.2 Attach Seat(C) to Left Armrest(A) and Backrest(D) using Bolts(①) and Washers(②) with Allen Key(③) as pictured.

Do not fully tighten the Bolts.

Step 3

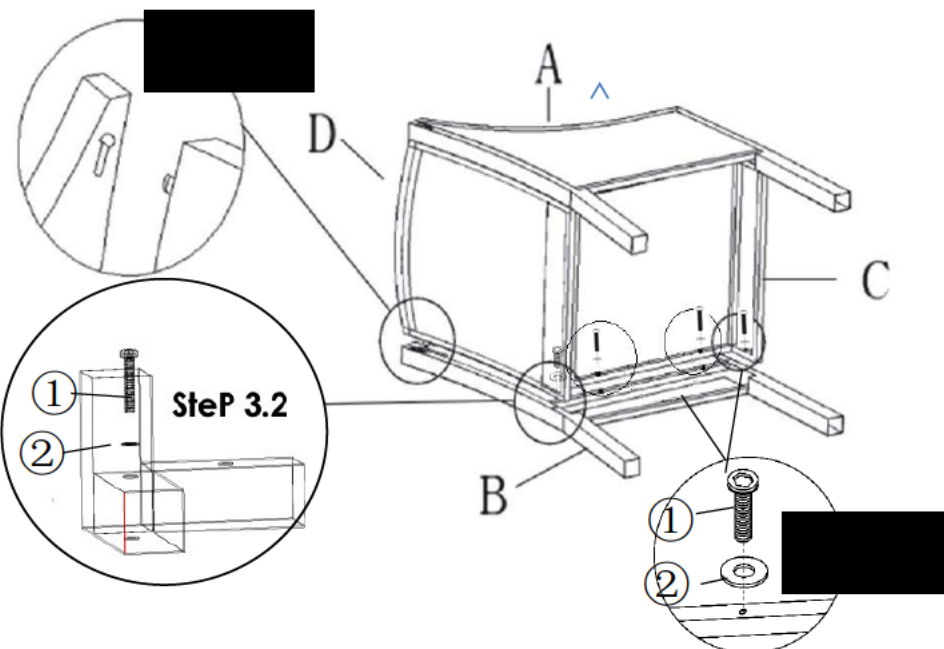

Align Right Armrest(B) to Backrest(D) and Seat(C).

3.1 Insert the Dowel on the Backrest(D) into the mounting position of the Right Armrest(B).

3.2 Attach Right Armrest(B) to Backrest(D) and Seat(C) using Bolts(①) and Washers(②) with Allen Key(③) as shown in the picture.

Stand the Chair up.

Exert pressure floorwards, onto the Chair with both your hands.

This pressure will help the Chair reach full alignments status.

Check for wobbles on a LEVEL surface.

If no wobbles are found proceed to tighten the Bolts and Screws in a sequential manner, until evenly secured.

When tightening the Bolts and Screws sequentially.

DO NOT tighten any Bolt or Screw fully and then move on towards the next one.

If there are still wobbles, loosen the Bolts and Screws and excute the same above process.

If the Chair is not stable it could lead to damage to the product.

Step 4













Put the Seat Cushion(E) on the Chair.

Your Dining Chair is ready for use.

This Dining Chair can only be used on the flat, level surface.

Care & Maintenance

-  ● Do not put hot items directly on furniture surface
 -  ● Do not clean furniture with harsh cleansers or polish.
 -  ● To obtain the longest lifespan of your outdoor products, minimizing exposure to direct sunlight is recommended.
 -  ● Children should not climb or jump on the furniture.
 -  ● Do not write on furniture without a padded barrier to protect the surface.
 -  ● To obtain the longest lifespan of your outdoor products, avoid extended and lengthy exposure to rain, snow, and direct sunshine. Whenever possible cover the product and /or place under patio or awnings.
 -  ● Not for commercial use. For residential use only .
 -  ● Stains may be removed with mild soap solution and damp cloth.
 -  ● Keep away from sources of ignition.
-
-  ● Dust and pick-up spills using a clean, non-colored, lint-free cloth.