

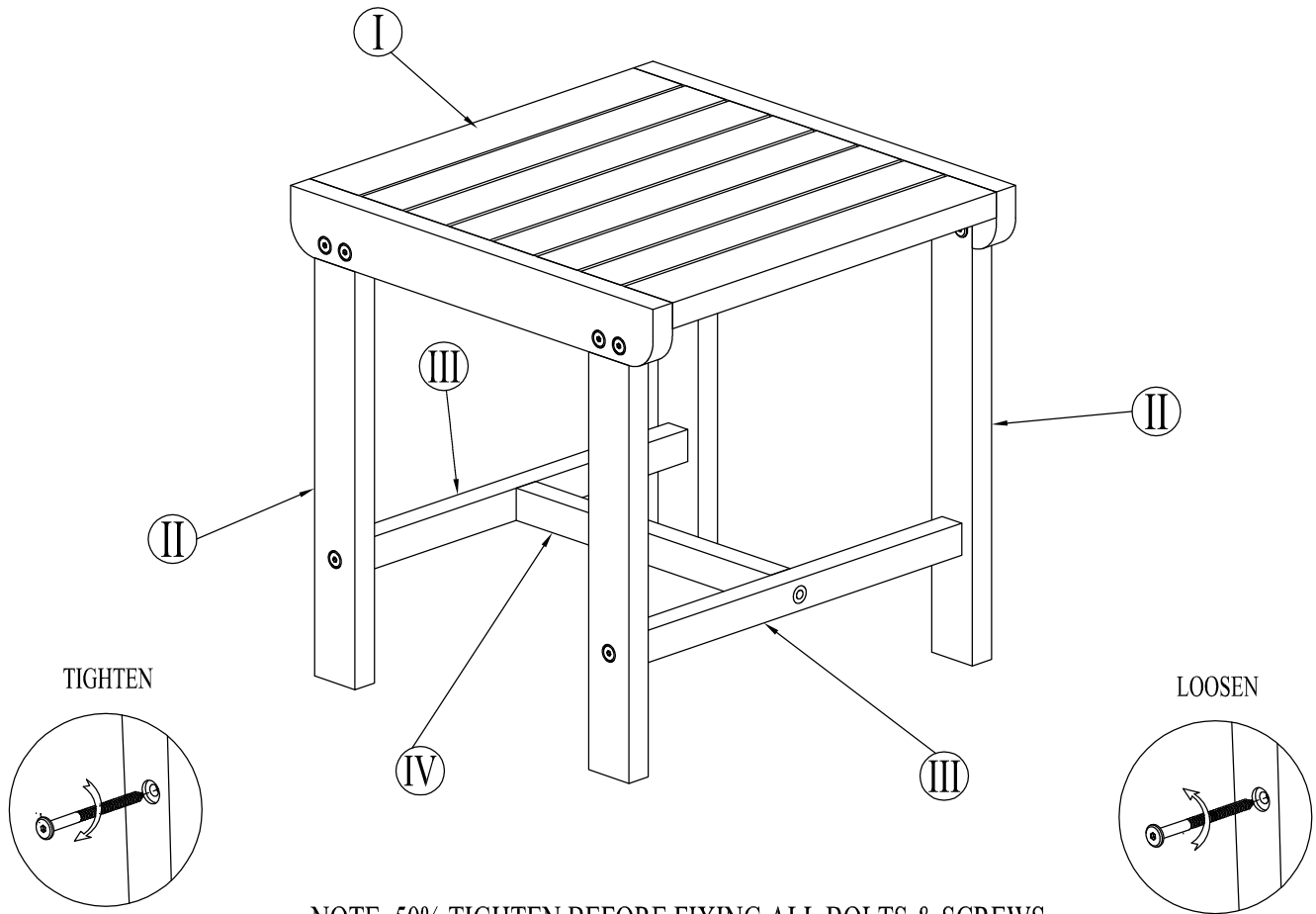

Maximum capacity : 40 kgs/88 Lbs







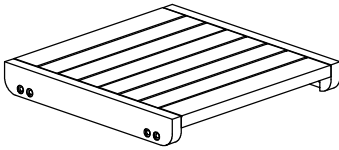

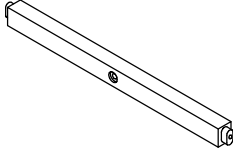
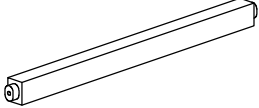
NOTE: 50% TIGHTEN BEFORE FIXING ALL BOLTS & SCREWS

COMPONENTS LIST

 <p>Q'TY 1</p>	 <p>Q'TY 4</p>	 <p>Q'TY 2</p>	 <p>Q'TY 1</p>
--	---	--	---

HARDWARE LIST

A		6	F - Screw 7x50	C		8	Sleeve nut
B		8	Bolt 6x15	D		2	Allen Key

Step 1

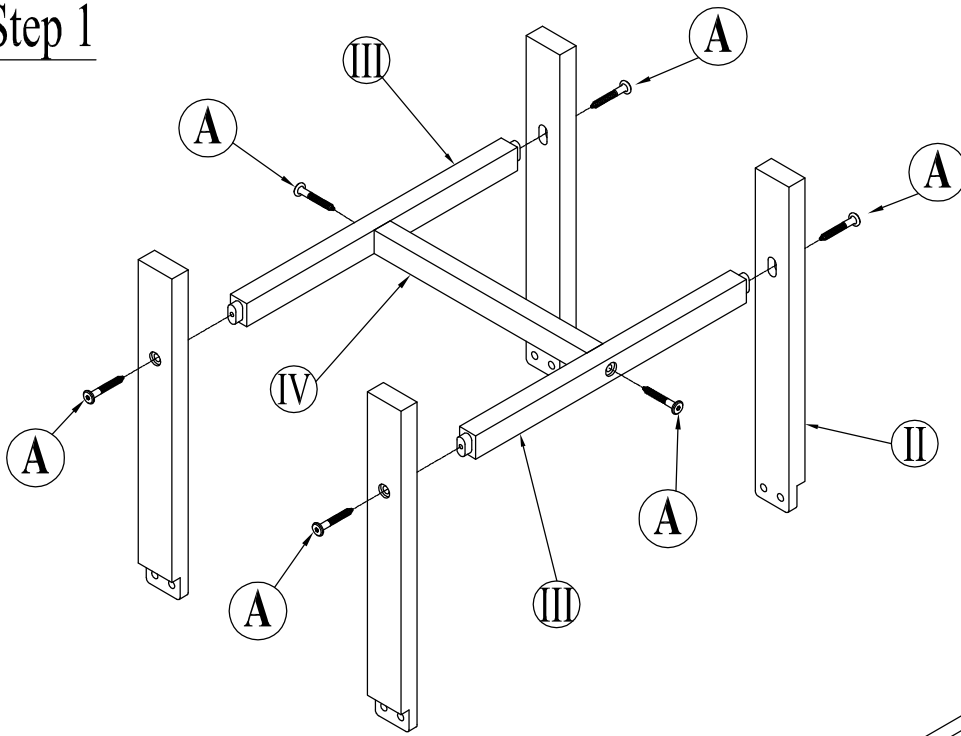

Step 2

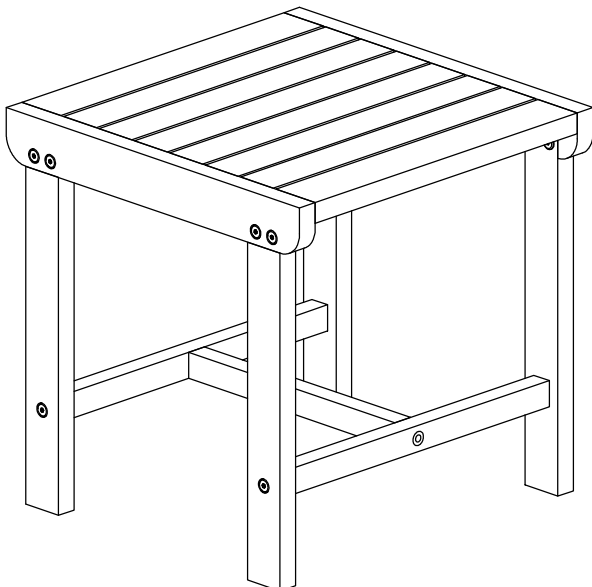
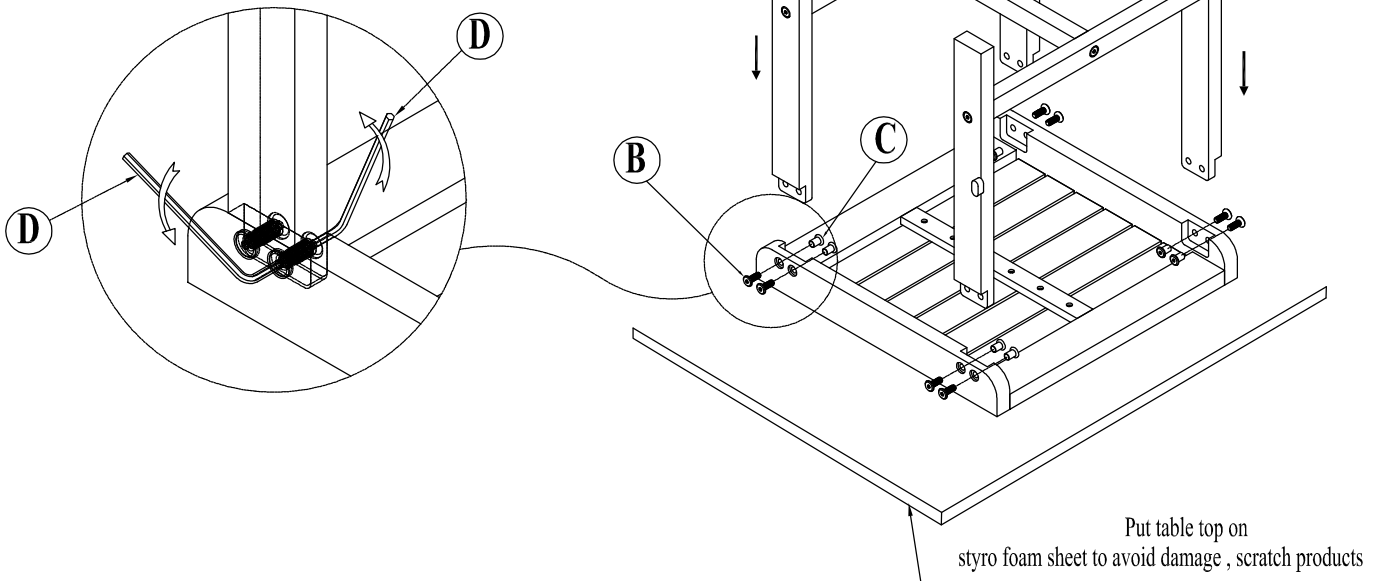

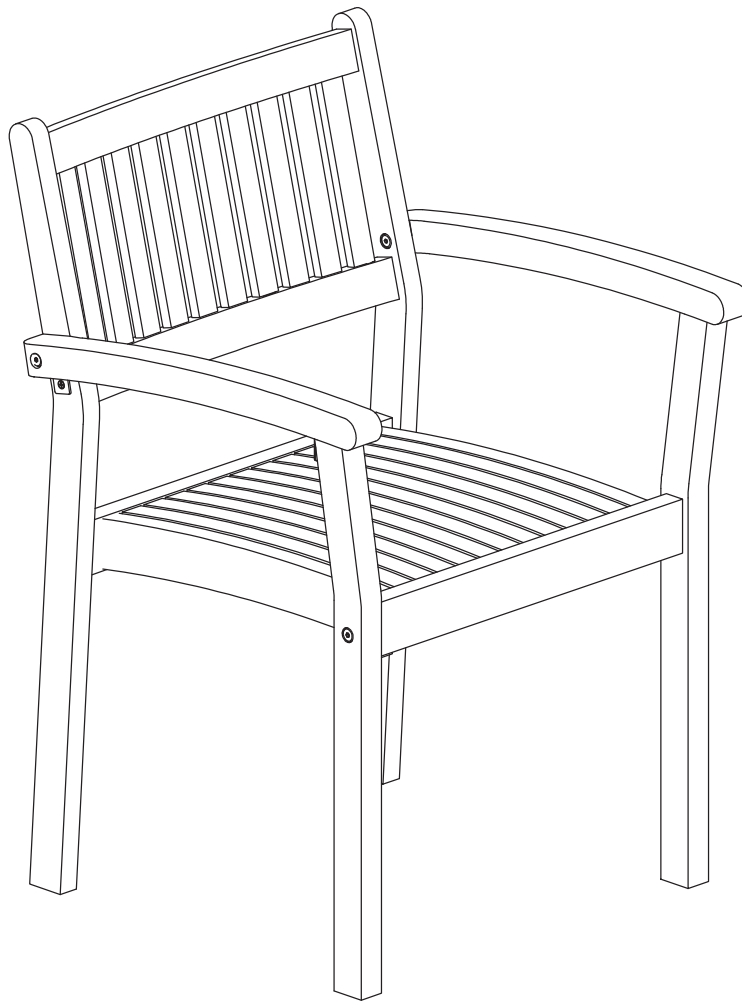

Maximum capacity : 110 kgs/242 Lbs



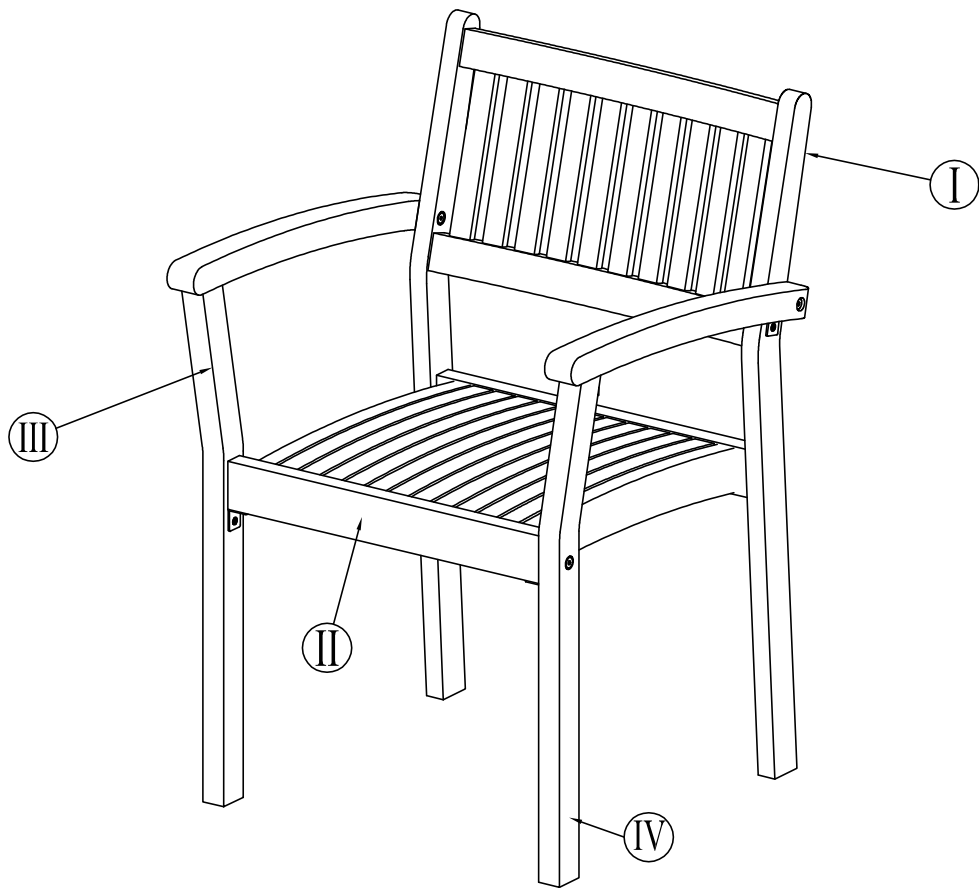





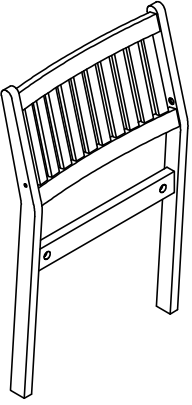
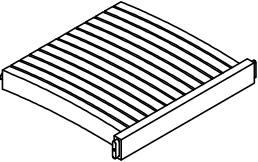

COMPONENTS LIST

HARDWARE LIST

<p>Ⓘ</p>  <p>Q'TY 2</p>	<p>Ⓜ</p>  <p>Q'TY 2</p>
--	--

A		2	F - Screw 7x70
B		2	F - Screw 7x90
C		2	F - Bolt 8x50
D		2	Sleeve nut 8 x15
E		4	Metal Bracket
F		8	C- Screw 4x20
G		2	Allen Key

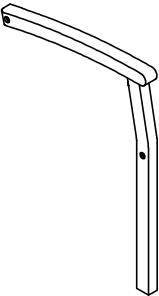
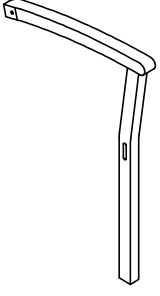
<p>Ⓜ</p>  <p>Q'TY 2</p>	<p>Ⓨ</p>  <p>Q'TY 2</p>
--	--

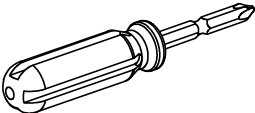
<p>SUPPORTING TOOLS</p>	
	<p>Screw driver</p>

Step 1

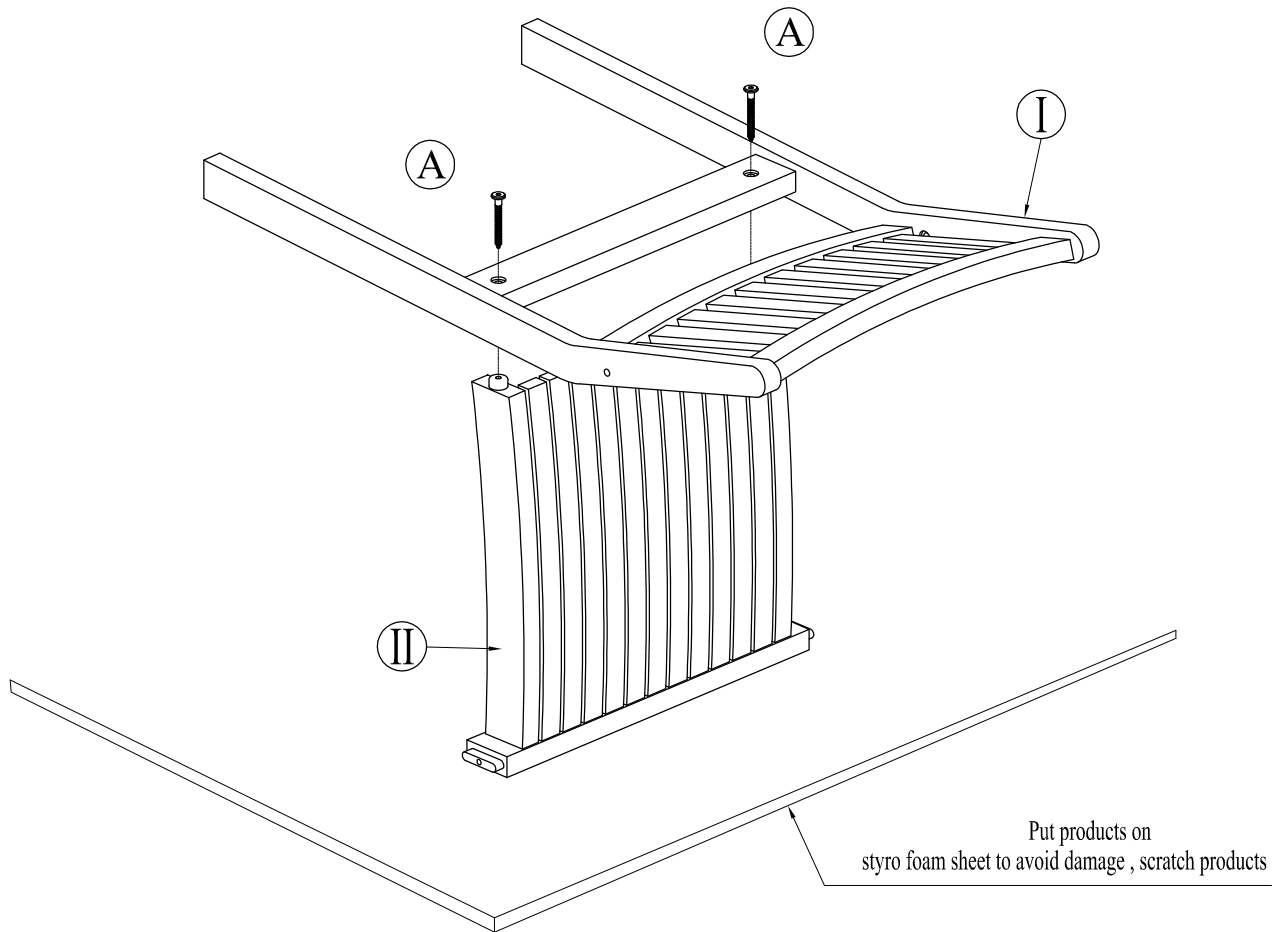

Step 2

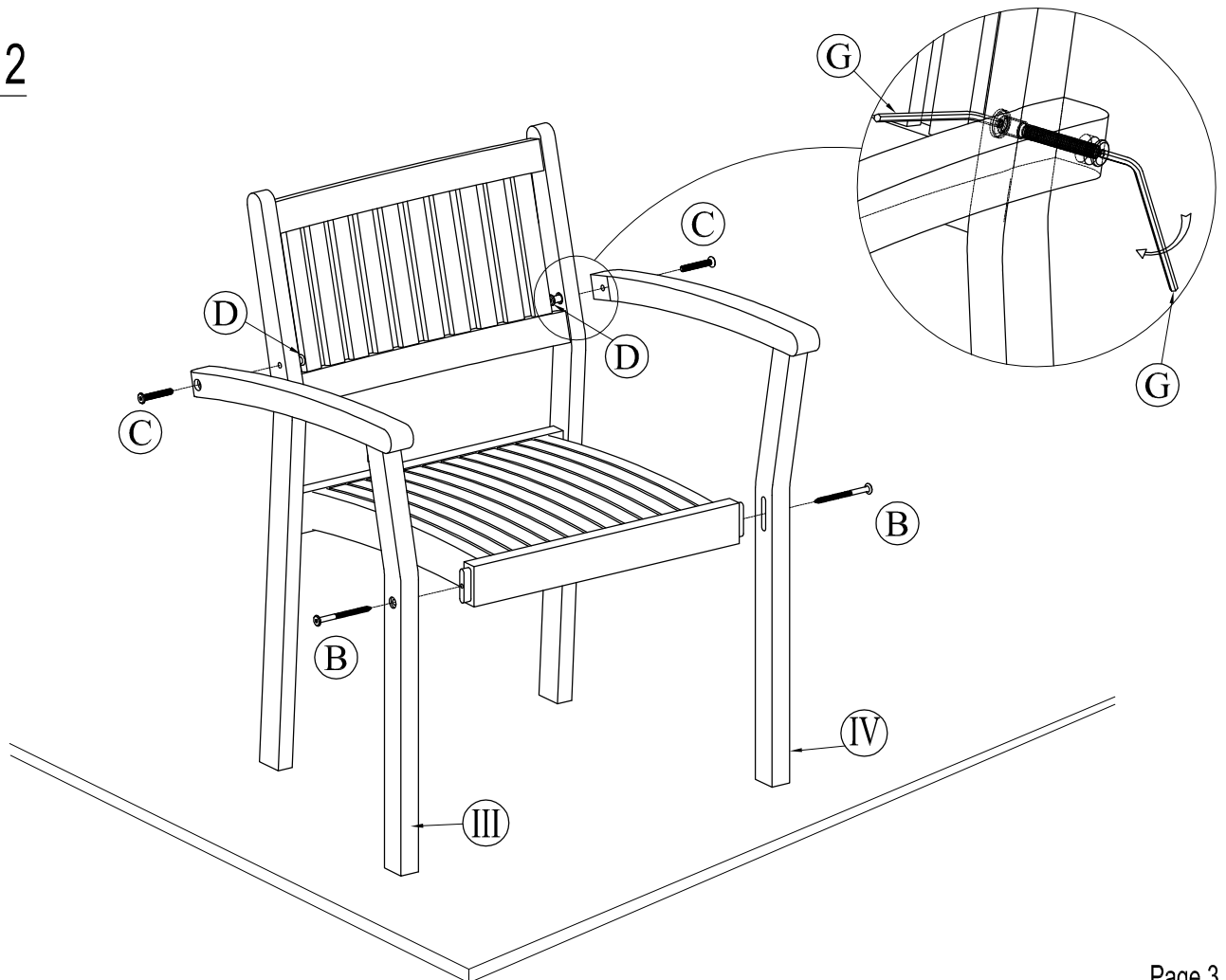

Step 3

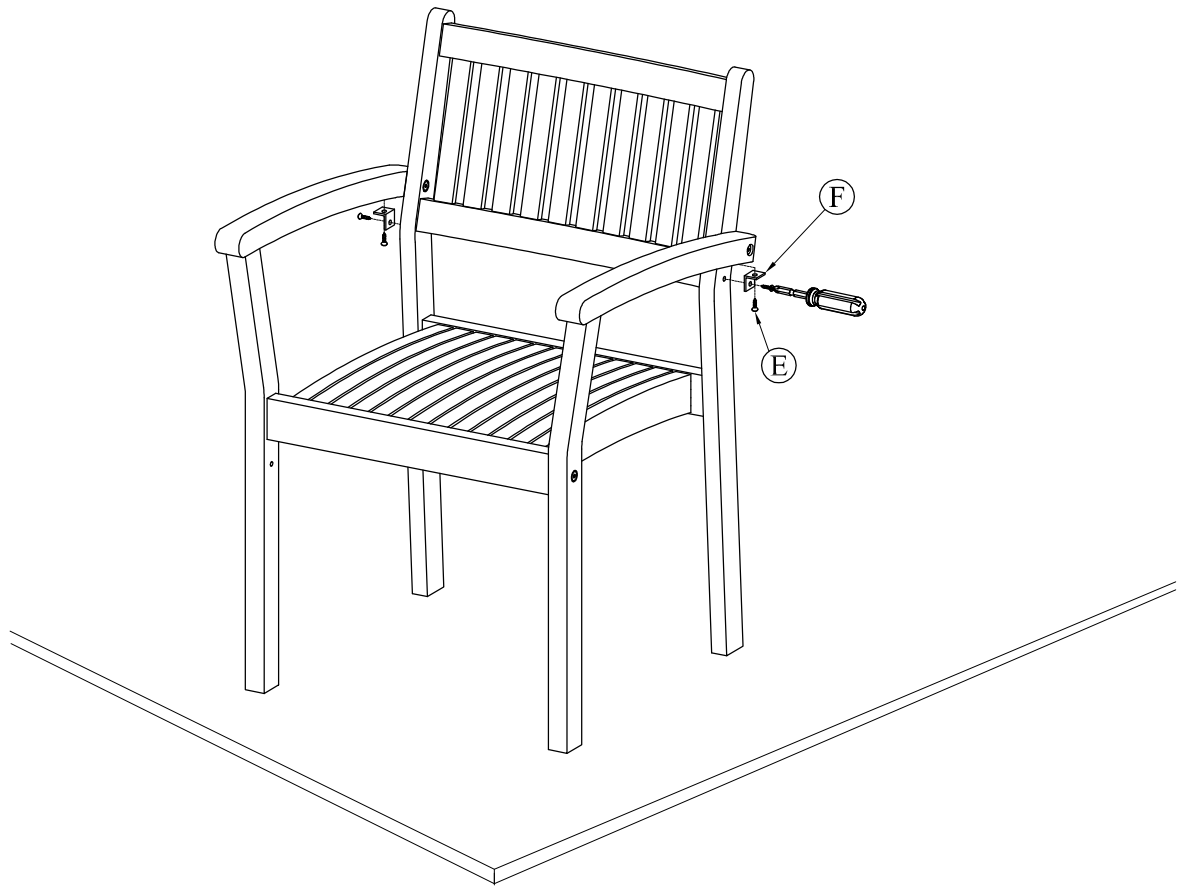

Step 4

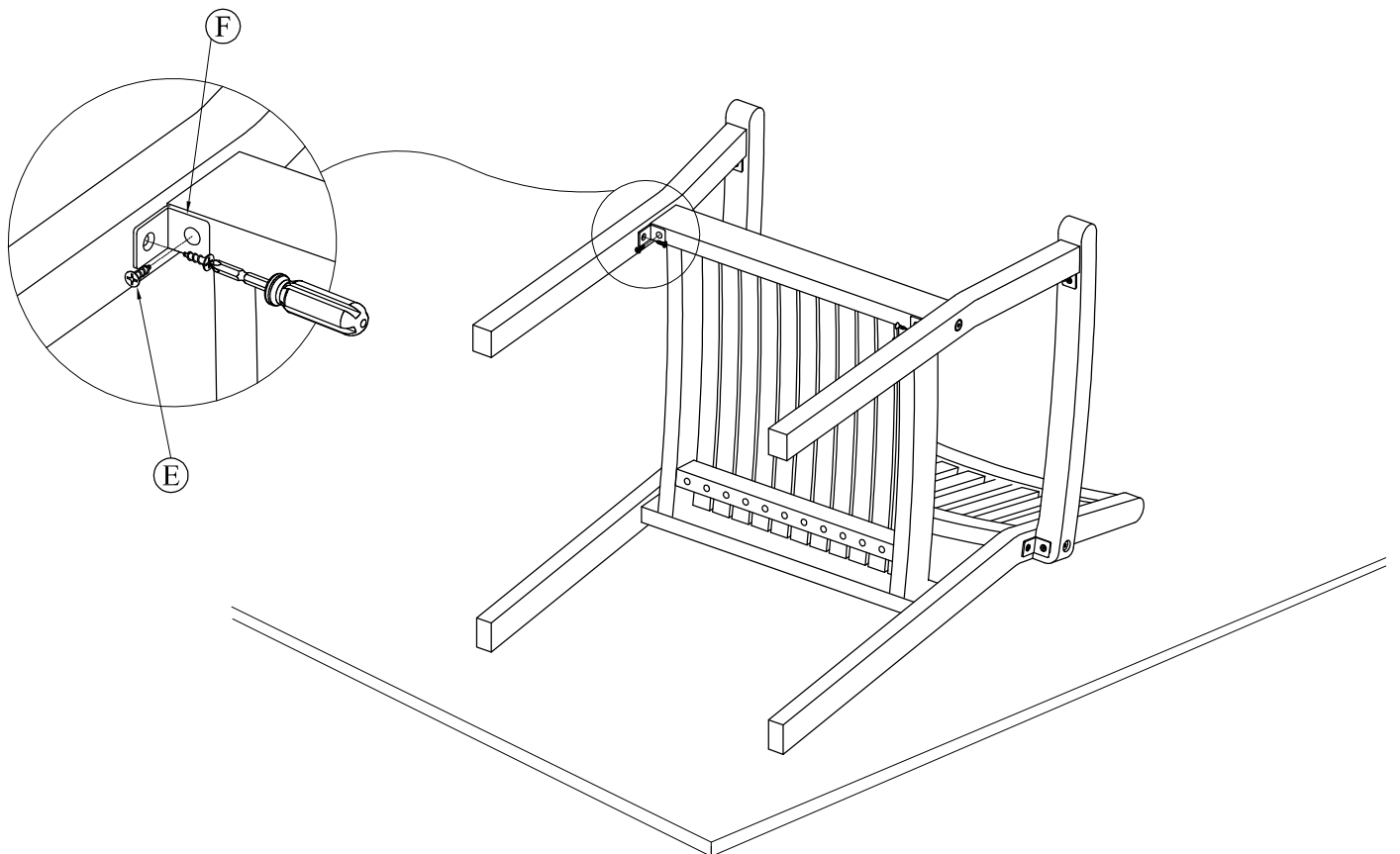

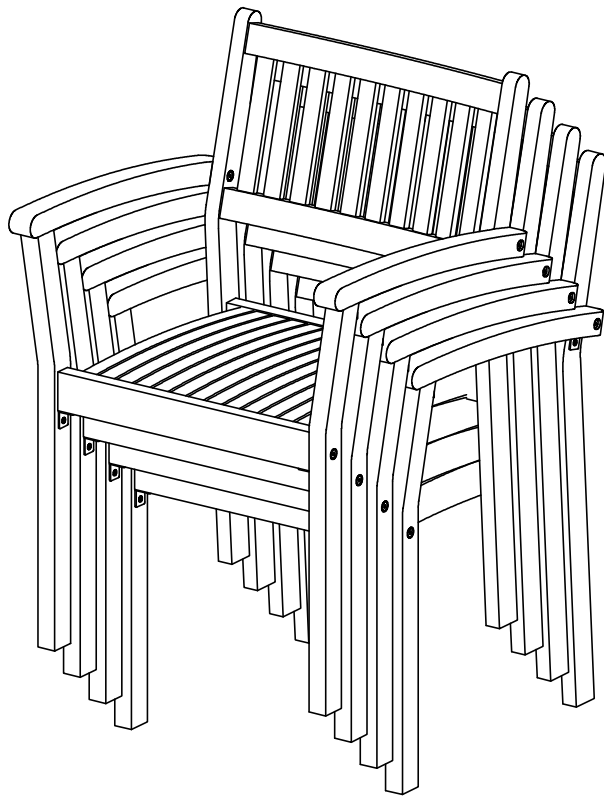
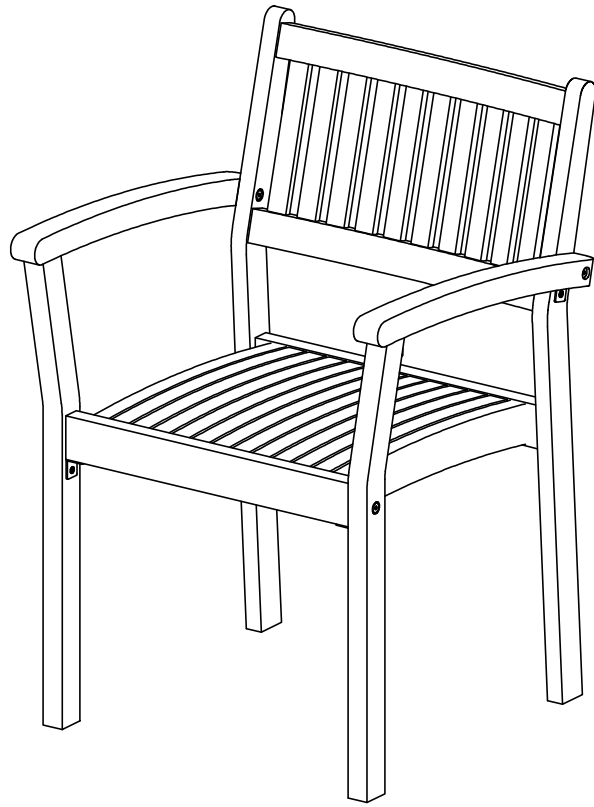

Warning: To ensure safety in using during please should not stack more than 4 chairs