

# *ASSEMBLY INSTRUCTIONS*

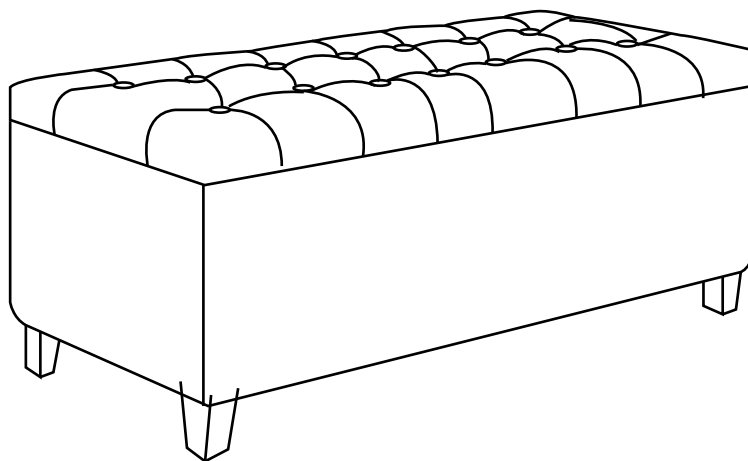

## ***Storage Bench***

# ASSEMBLY INSTRUCTIONS

## ASSEMBLY TIPS:

1. Remove hardware from box and sort by size.
2. Please check to see that all hardware and parts are present prior to start of assembly.
3. Please follow attached instructions in the same sequence as numbered to assure fast & easy assembly.



### WARNING!

1. Don't attempt to repair or modify parts that are broken or defective. Please contact the store immediately.
2. This product is for home use only and not intended for commercial establishments.



ASSEMBLY TIME

10 MINUTES

## PARTS IDENTIFICATION

A

STORAGE  
BENCH

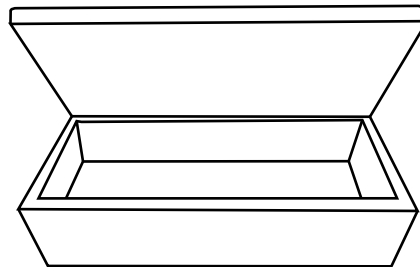

1PC

B

LEG



4PCS

## HARDWARE IDENTIFICATION

1

PAN HEAD SCREW  
(M4 X 45MM-BLK)



8PCS

### NOTE:

Phillips head screw driver is required in the assembly process; however, manufacturer does not provide this item.

# ASSEMBLY INSTRUCTIONS

## STEP 1

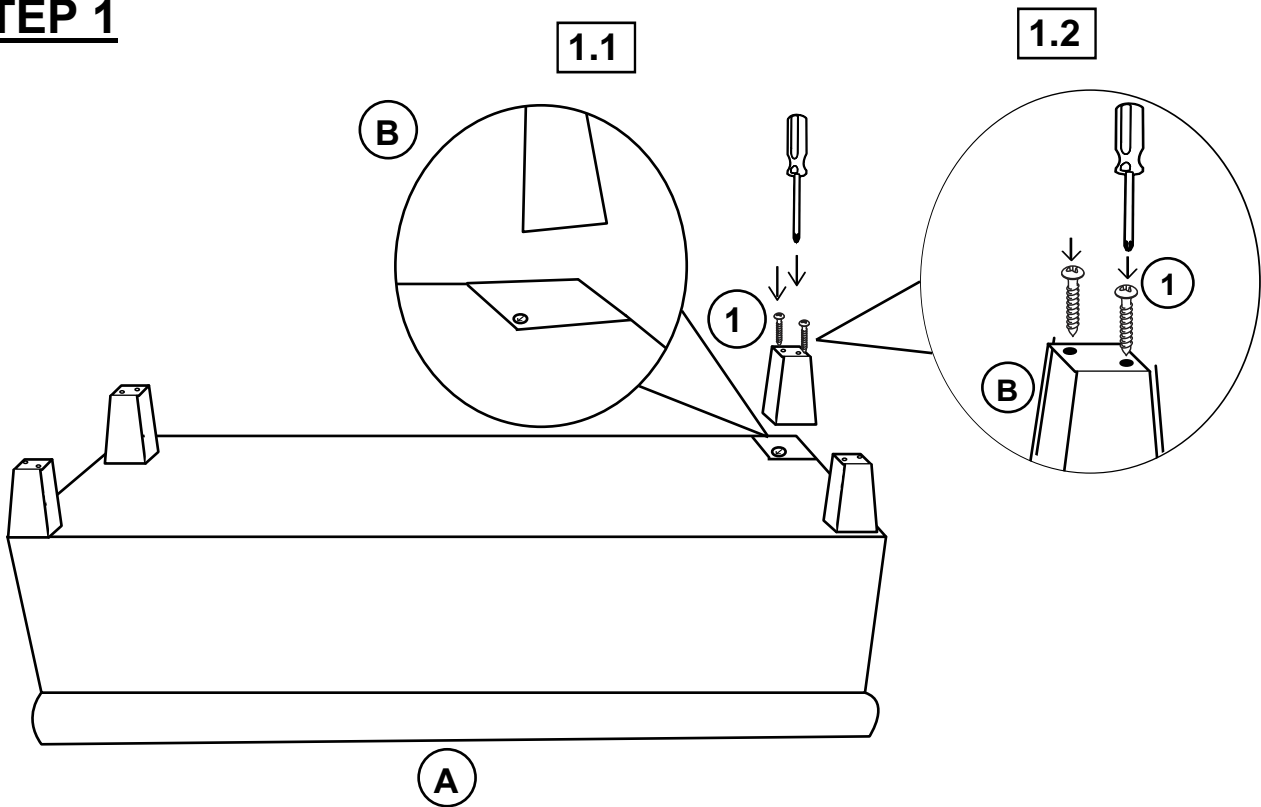

## STEP 2 COMPLETE

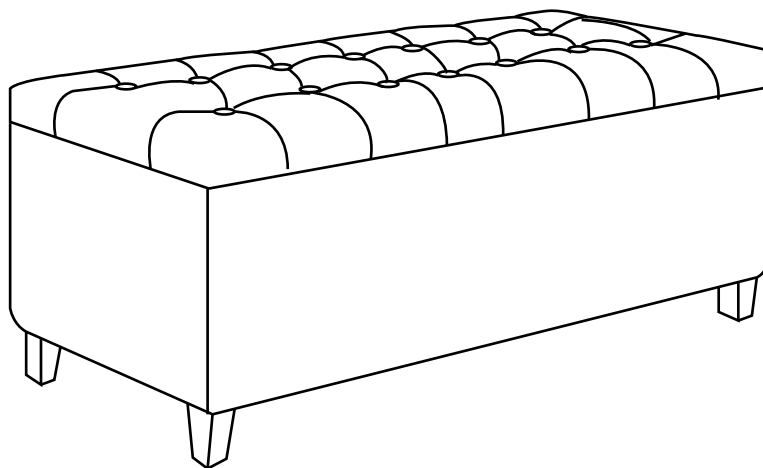

**INNER SIZE OF DRAWER : 14.59" x 40.35" X 11.61"**

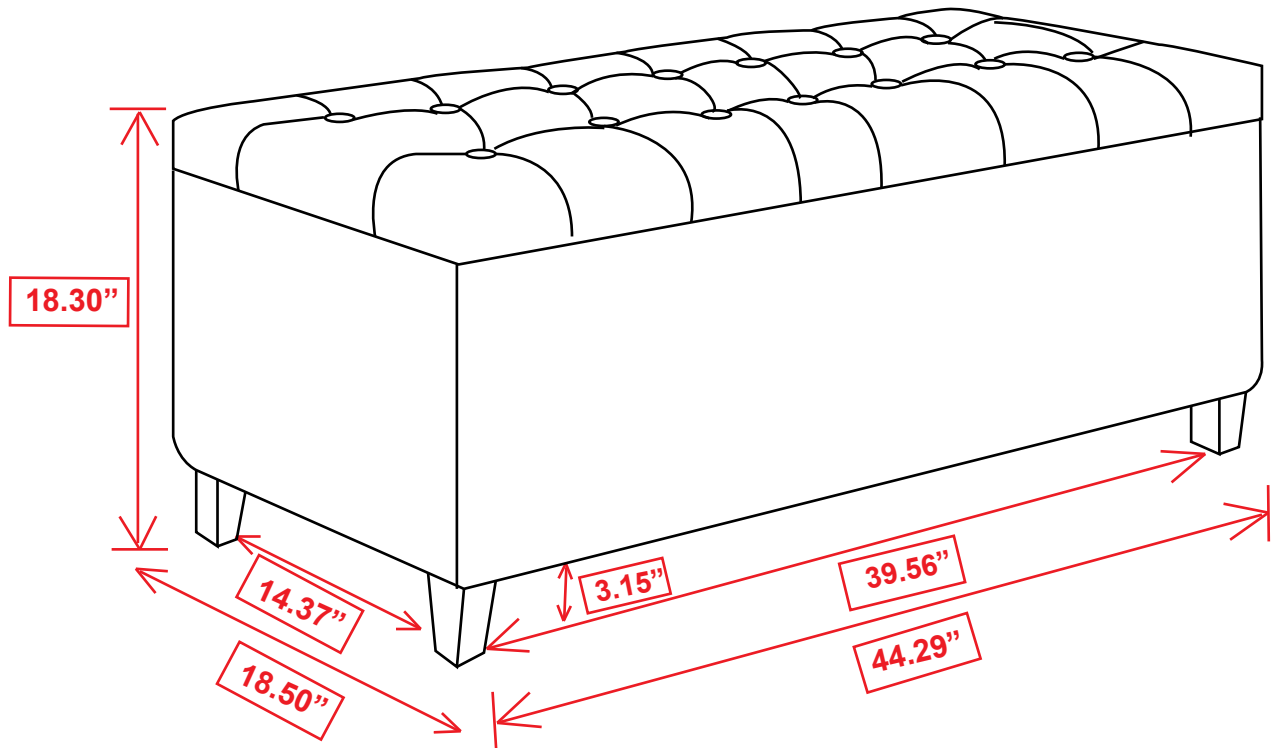

**Note :** Dimension tolerance  $\pm 5\%$