

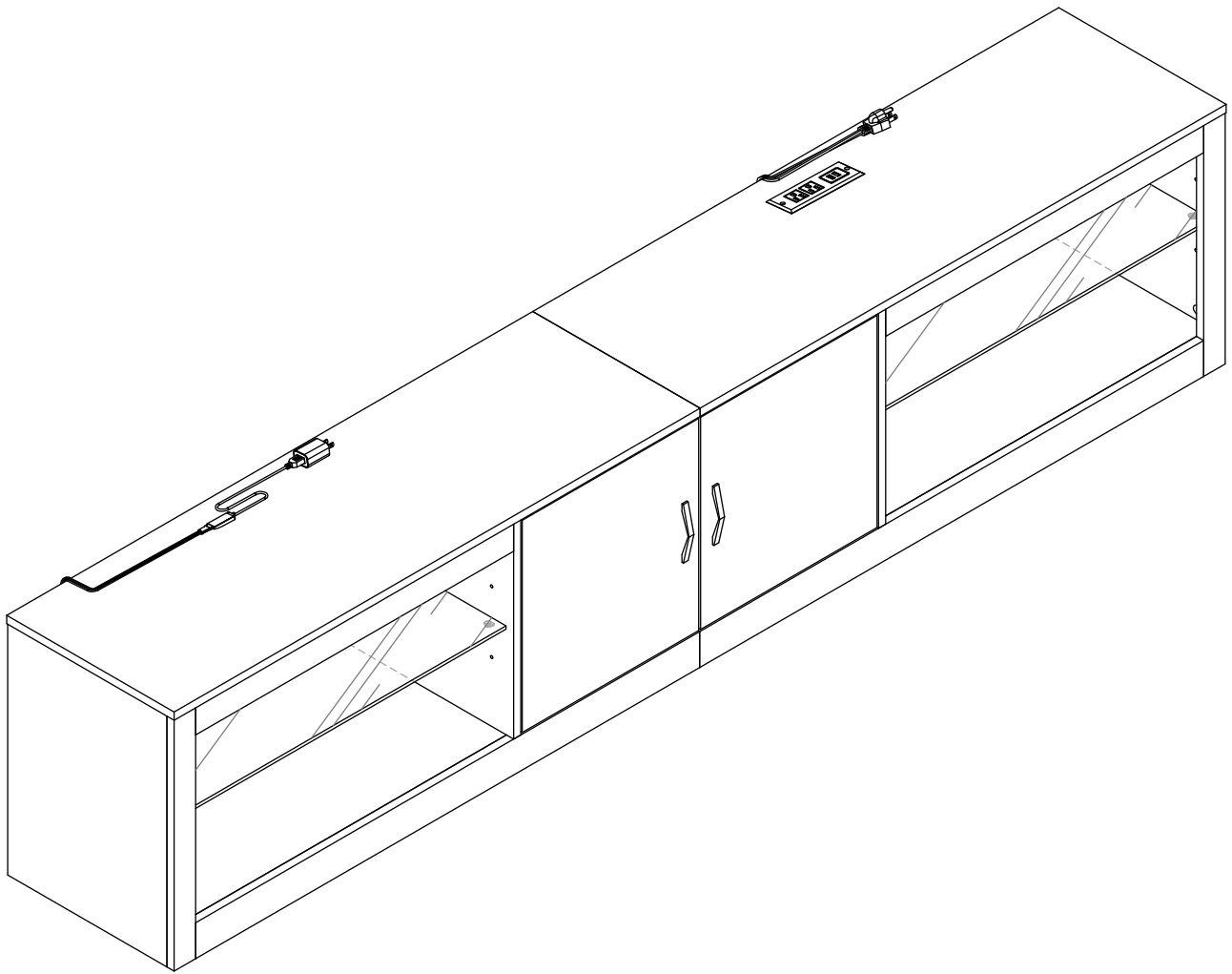

205CM/220CM

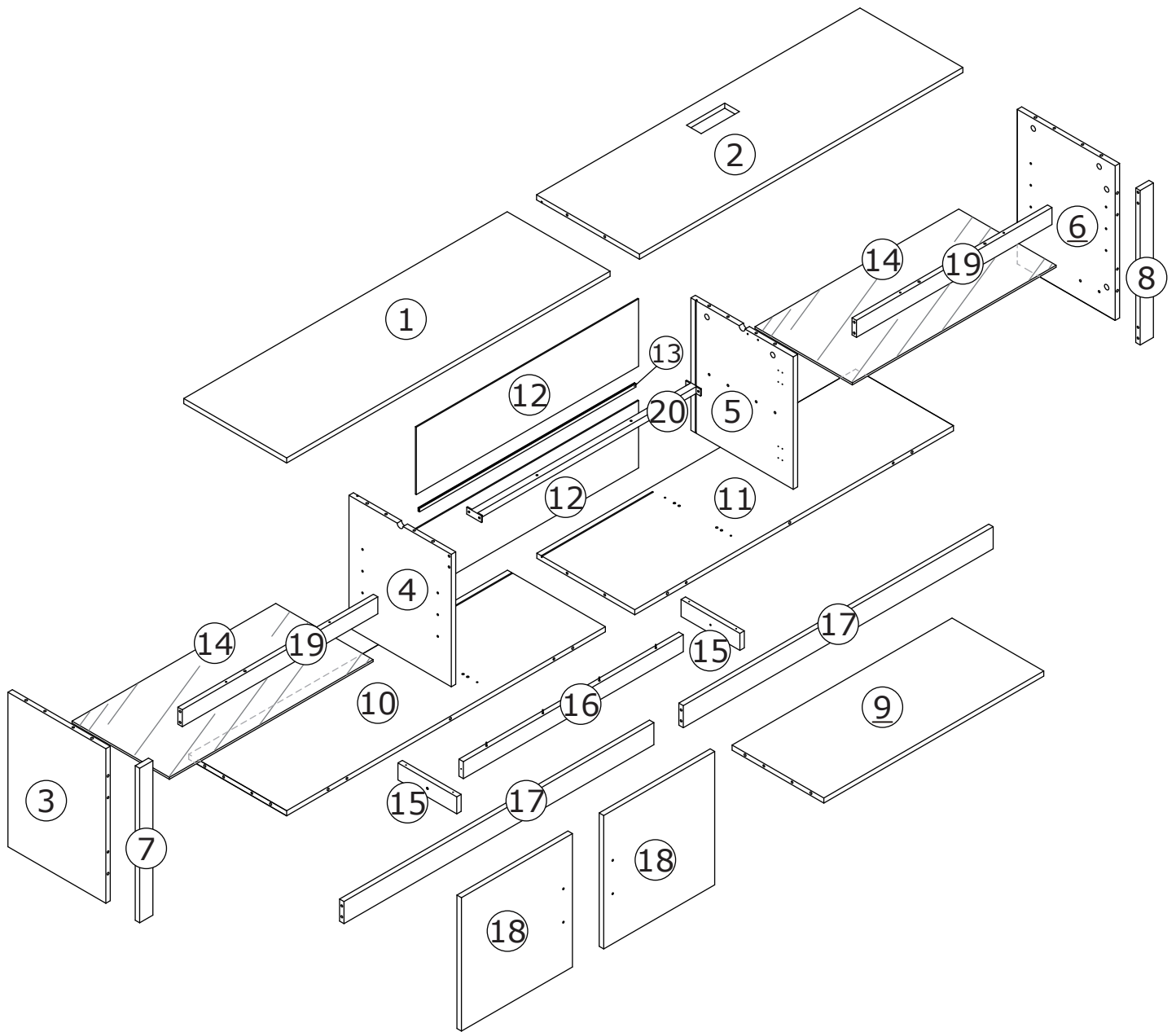

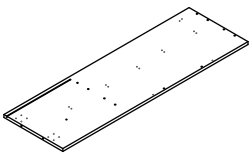

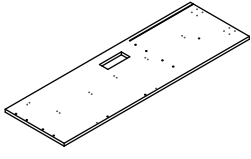
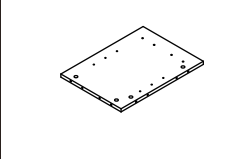
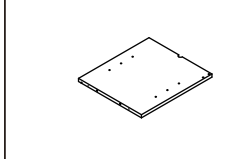
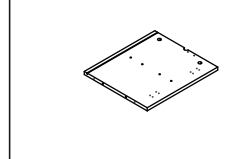
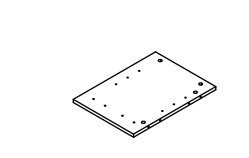
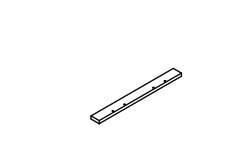
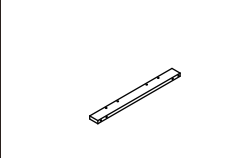
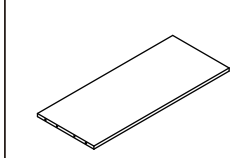
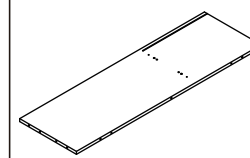
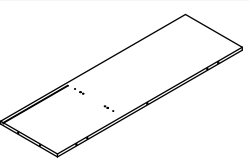
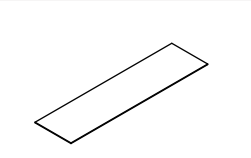

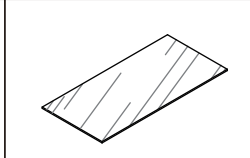
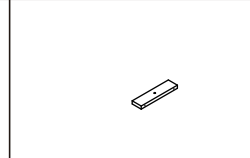
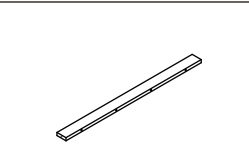
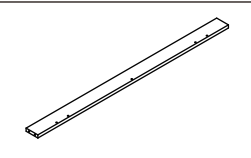
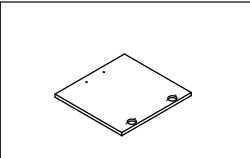
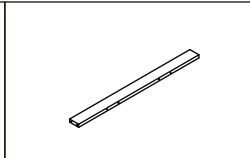
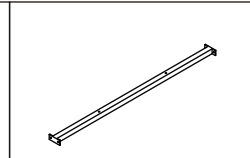



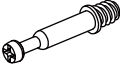

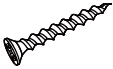

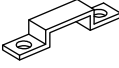

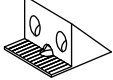
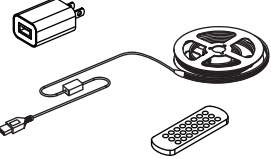

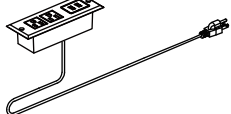



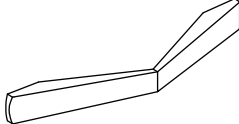

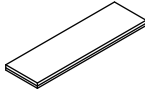
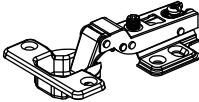
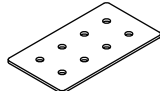
Parts and Operation Elements

				
① 1pc	② 1pc	③ 1pc	④ 1pc	⑤ 1pc
				
⑥ 1pc	⑦ 1pc	⑧ 1pc	⑨ 1pc	⑩ 1pc
				
⑪ 1pc	⑫ 2pcs	⑬ 1pc	⑭ 2pcs	⑮ 2pcs
				
⑯ 1pc	⑰ 2pcs	⑱ 2pcs	⑲ 2pcs	⑳ 1pc

Hardware

			
Cam Bolt	Cam Lock	Ø6x30mm Dowel	M4x40mm Screw
(A) 26pcs ^{+2pcs}	(B) 26pcs ^{+2pcs}	(C) 44pcs ^{+2pcs}	(D) 18pcs ^{+2pcs}
			
M3x12mm Screw		M3x16mm Screw	
(E) 24pcs ^{+2pcs}	(F) 11pcs ^{+2pcs}	(G) 4pcs	(H) 4pcs
			
			M4x14mm Screw
(J) 1pc	(K) 8pcs ^{+1pcs}	(L) 1pc	(M) 24pcs ^{+2pcs}
			
Ø8x40mm Dowel	M4x18mm Screw		
(N) 4pcs	(P) 4pcs	(Q) 2pcs	(R) 26pcs ^{+2pcs}
			
			M6x12mm Screw
(S) 16pcs ^{+2pcs}	(T) 4pcs	(U) 4pcs	(V) 32pcs ^{+2pcs}
			
M4x14mm Screw	M6x30mm Screw		Ø6x40mm Dowel
(W) 4pcs	(X) 2pcs	(Y) 1pc	(Z) 2pcs

General instructions to assemble connecting pieces

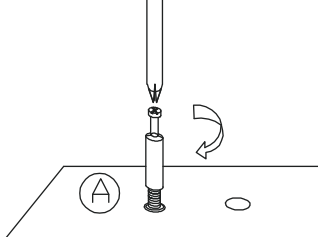
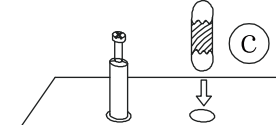
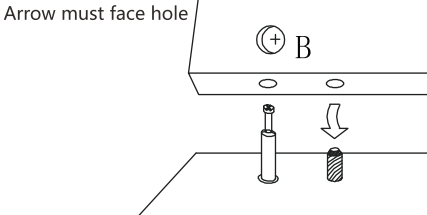
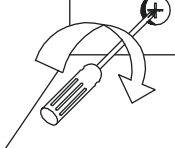
			
Gently screw cam bolt into the threaded anchor.	Insert the wood dowel halfway into hole.	Arrow must face hole	Screw the camlock firmly into locked position.

1

Tear off the film of plates 17 before assembly.

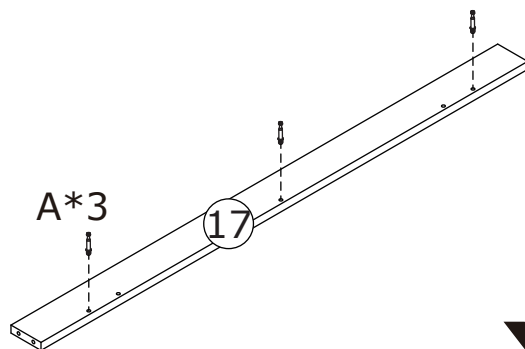

x2

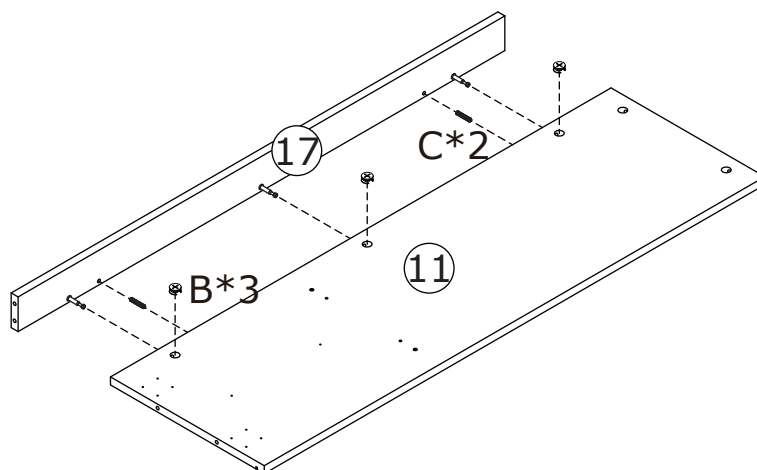
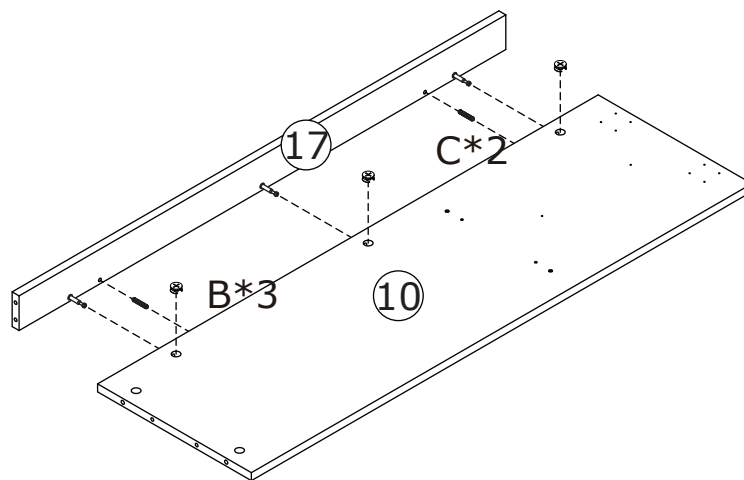
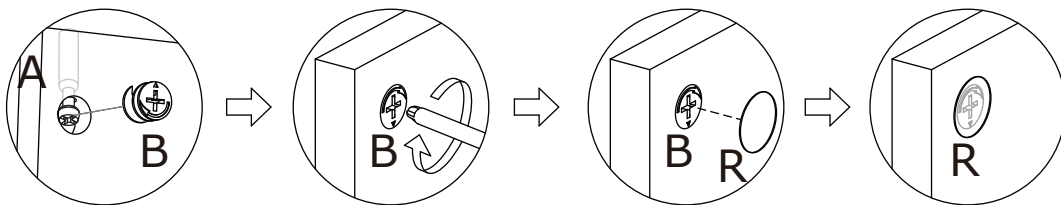
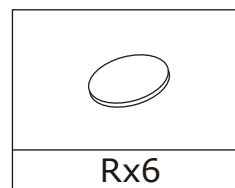
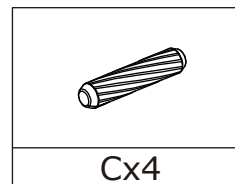
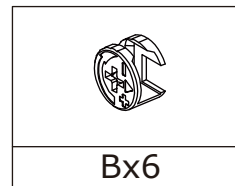
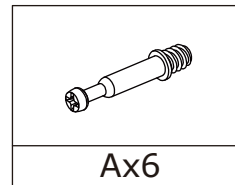

2

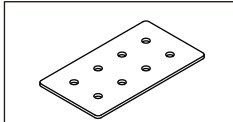
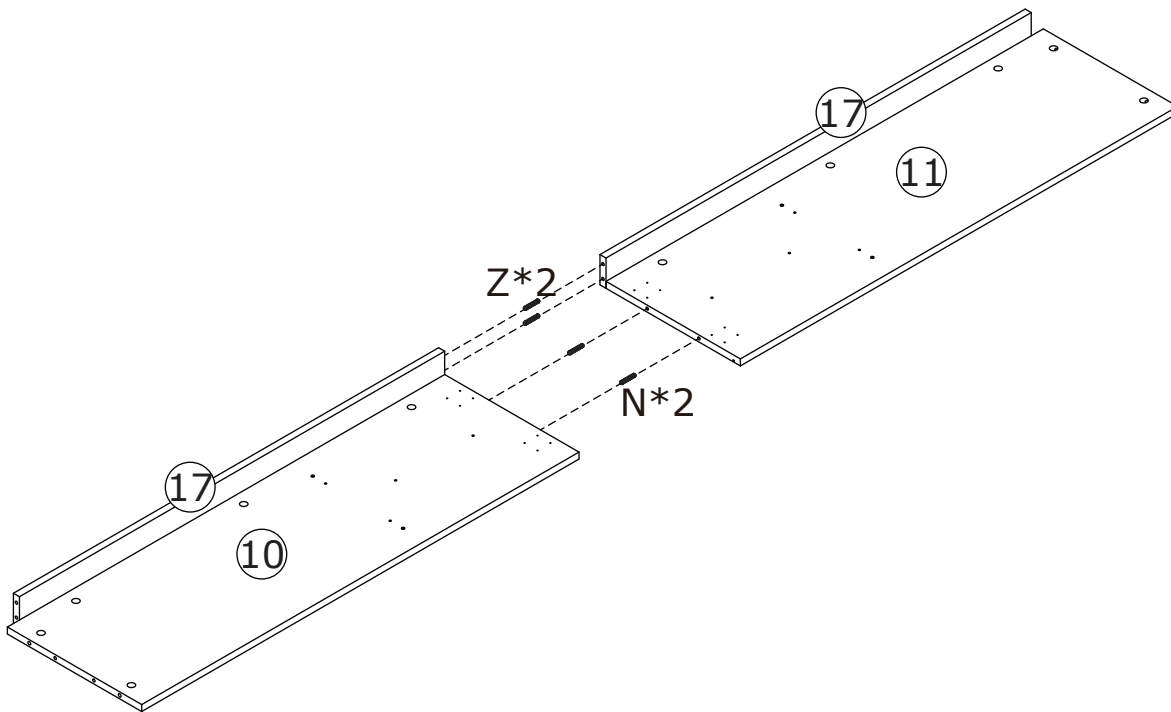

Ux2

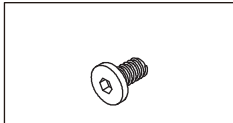

Vx16

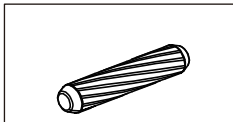

Nx2

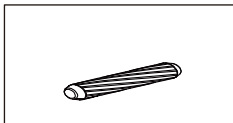

Zx2

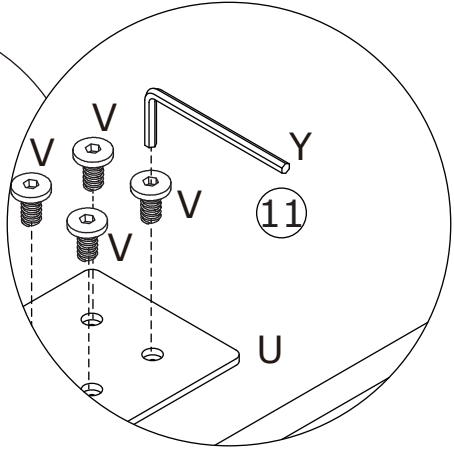
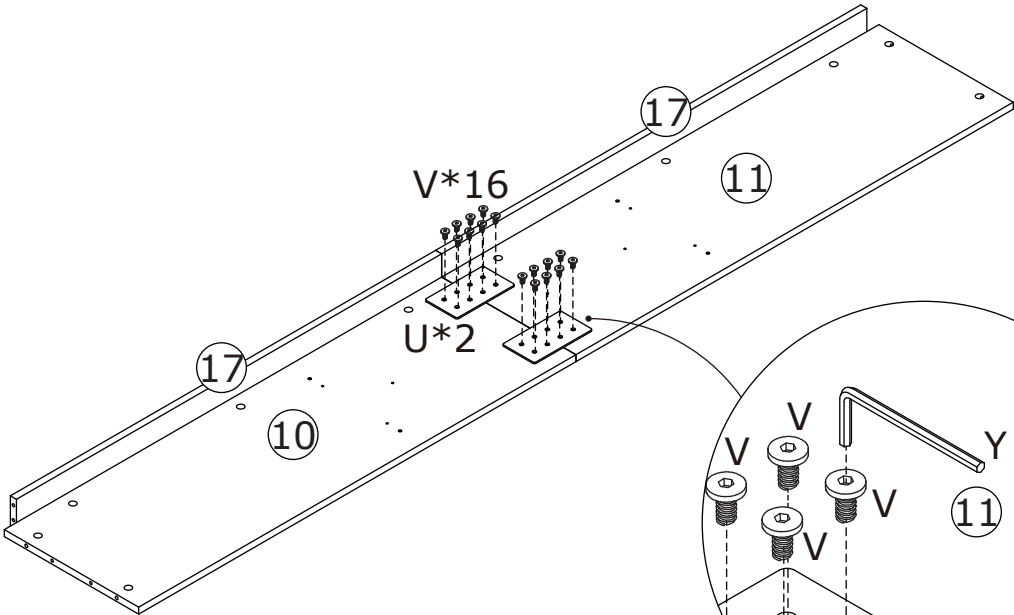

3

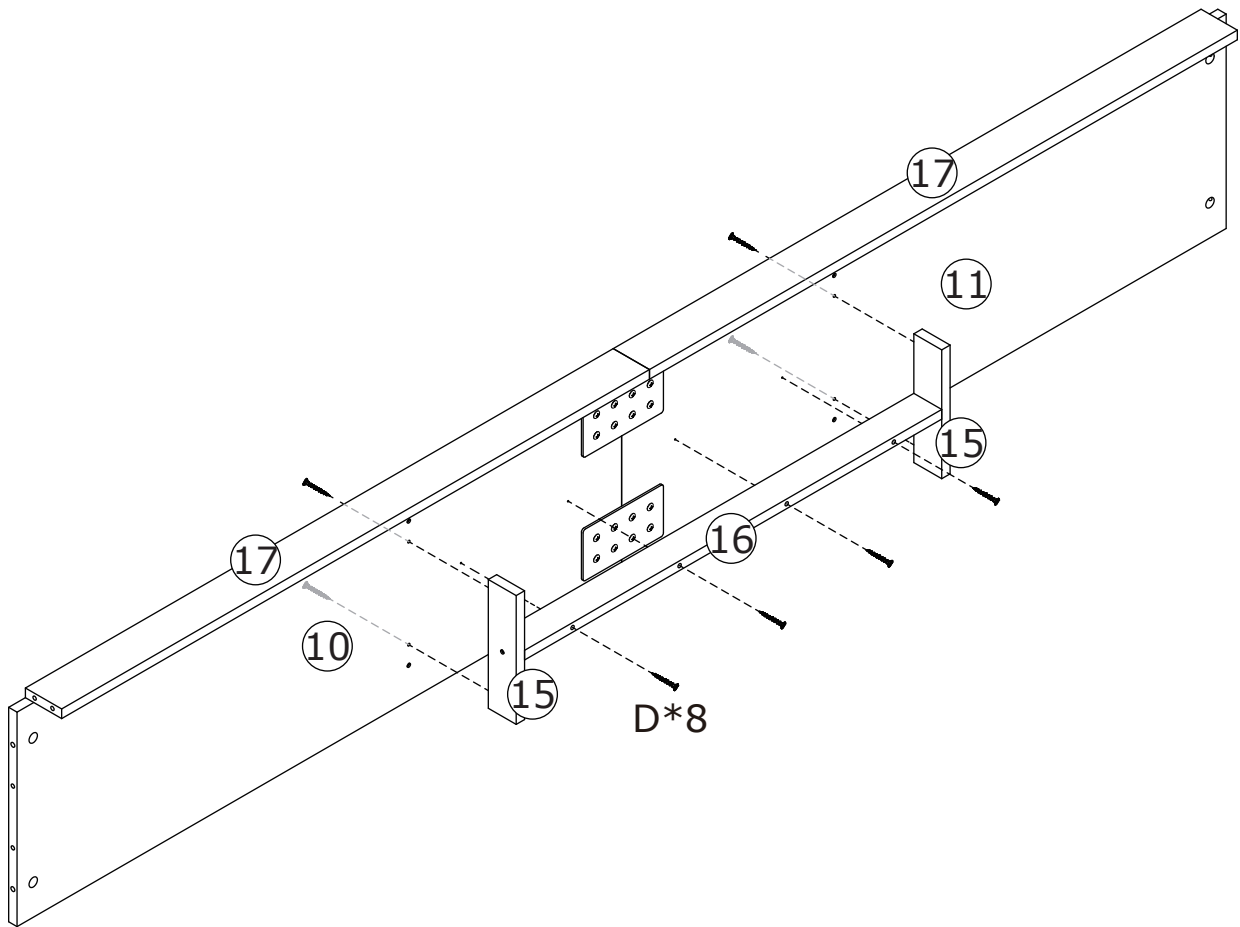
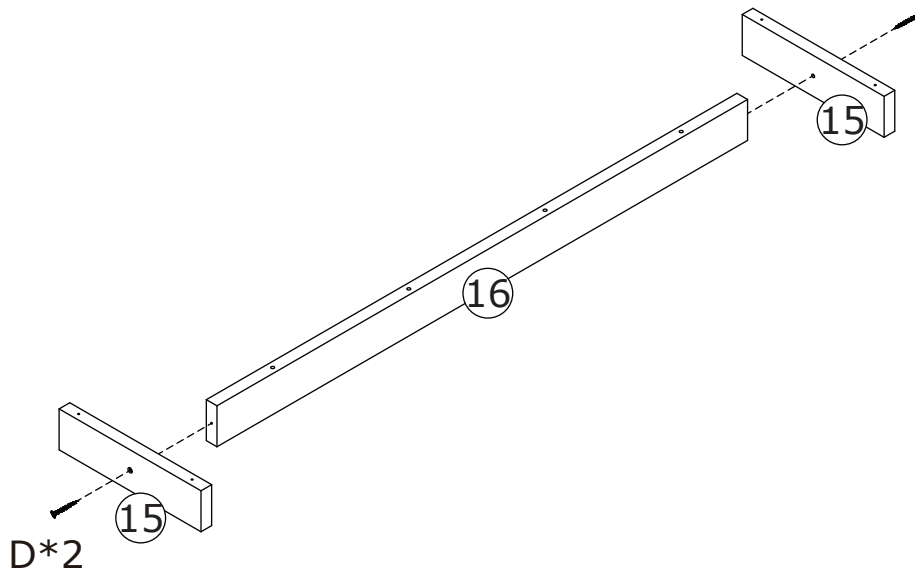
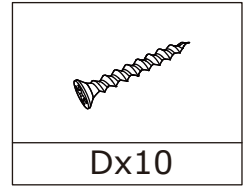

4

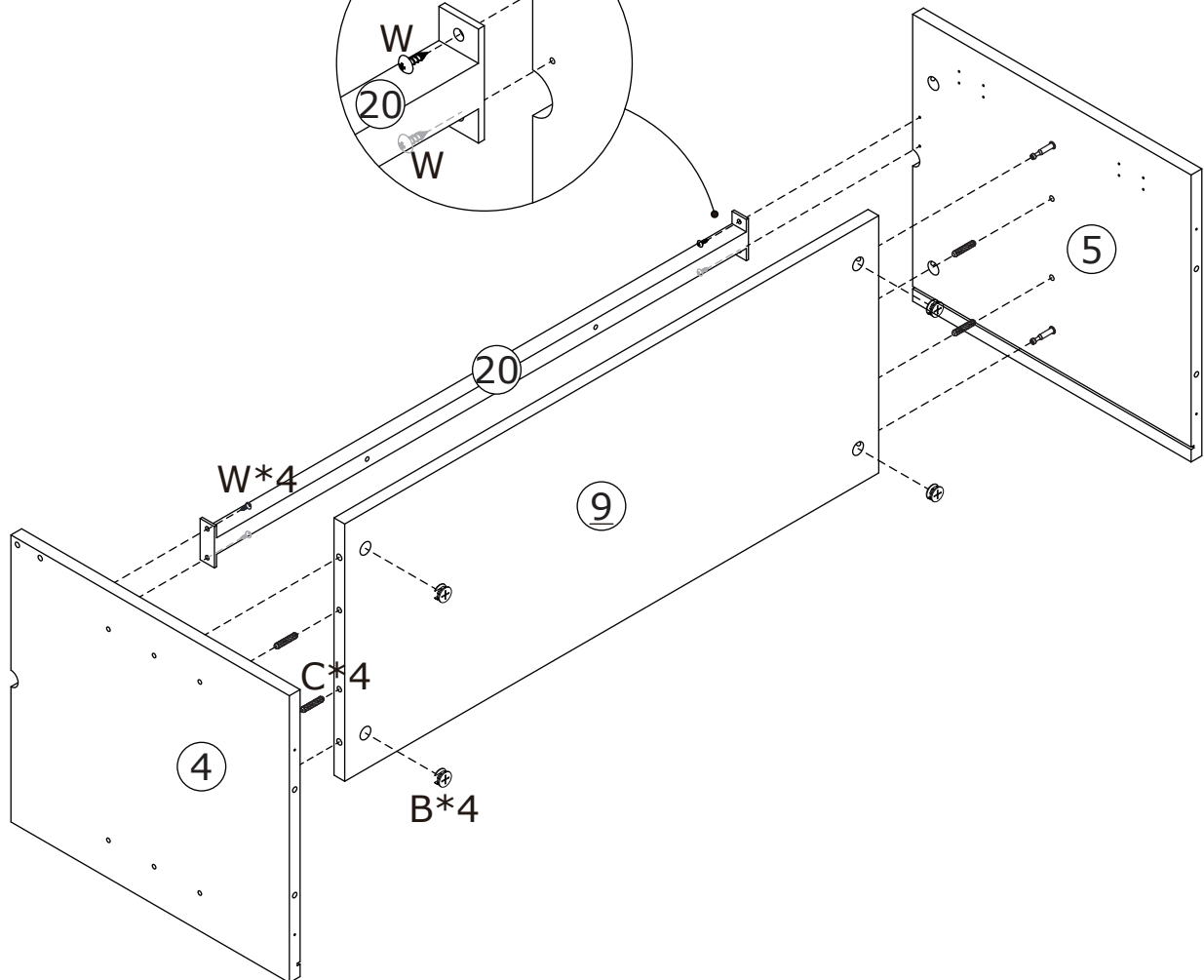
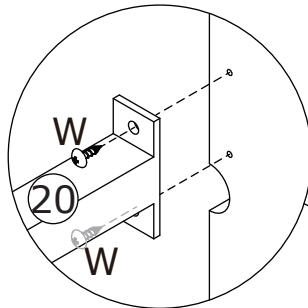
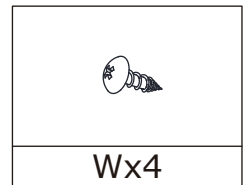
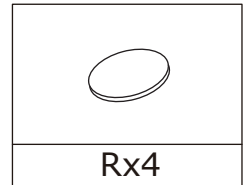
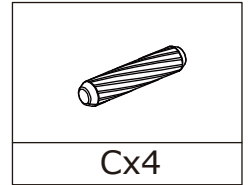
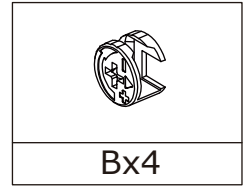
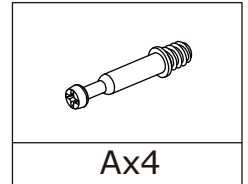
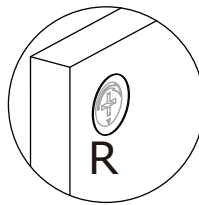
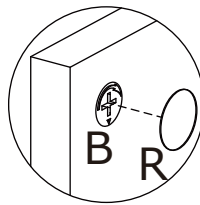
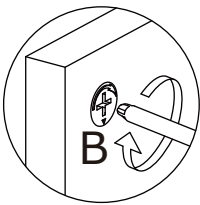
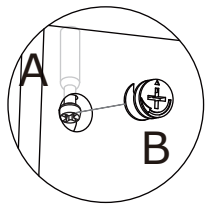
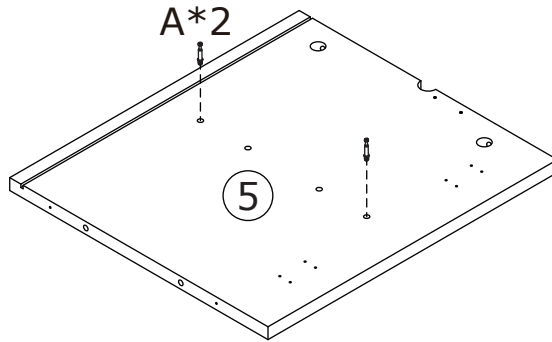
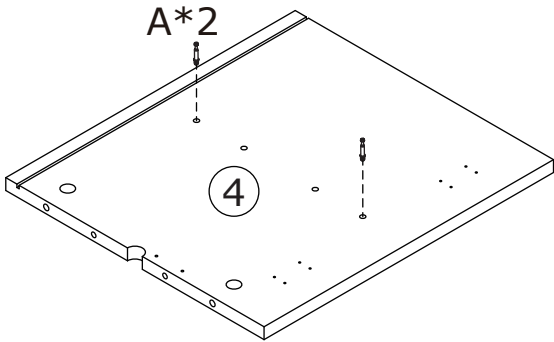

6

Tear off the film of plates 7 and 8 before assembly.

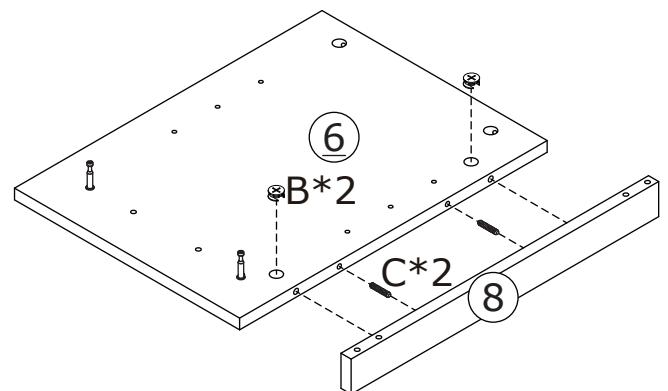
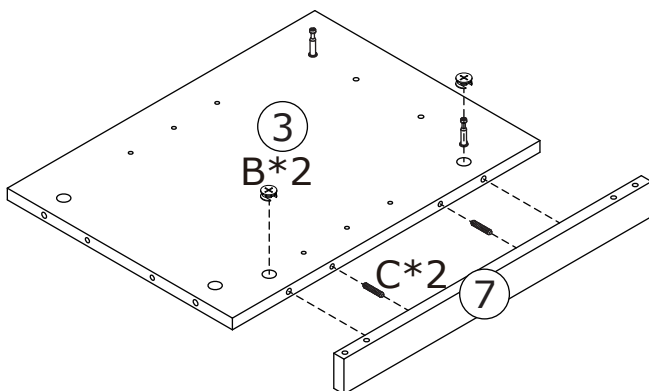
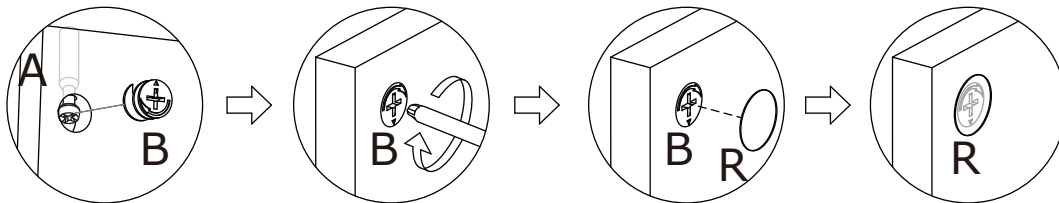
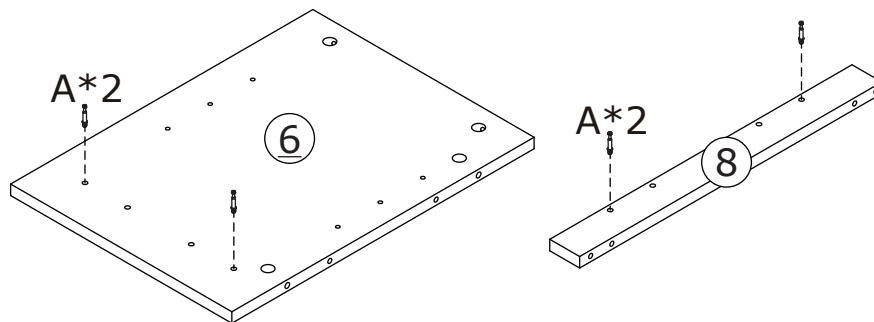
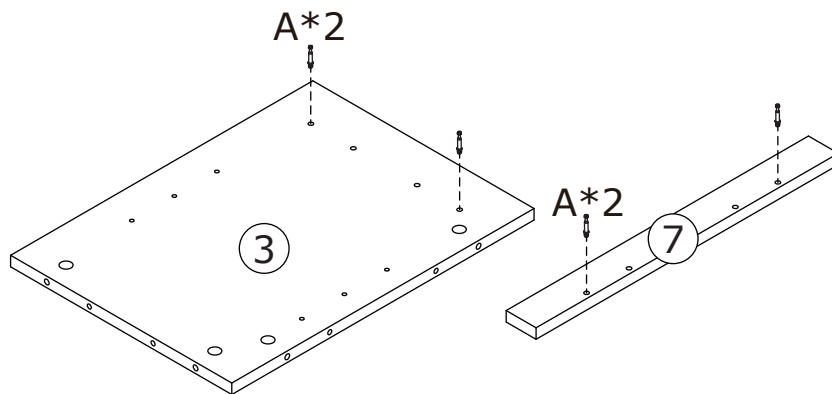
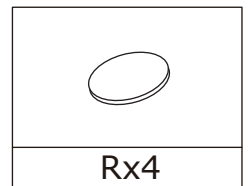
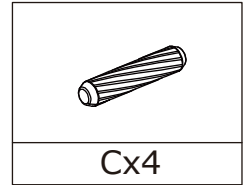
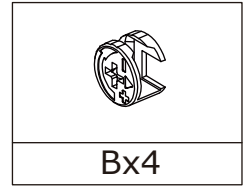
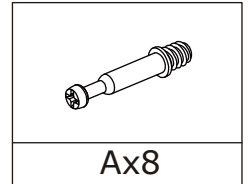

7

Tear off the film of plates 19 before assembly.

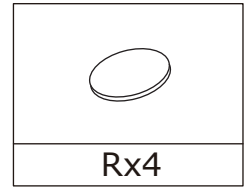
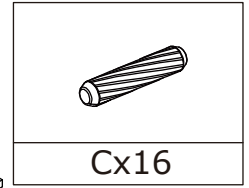
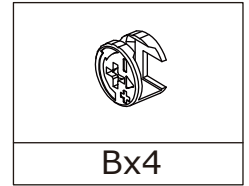
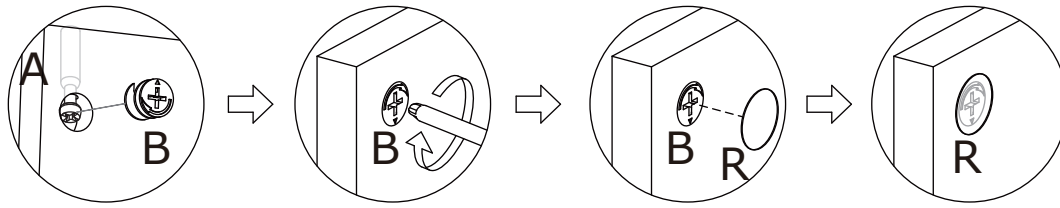

High-gloss edge banding outward.

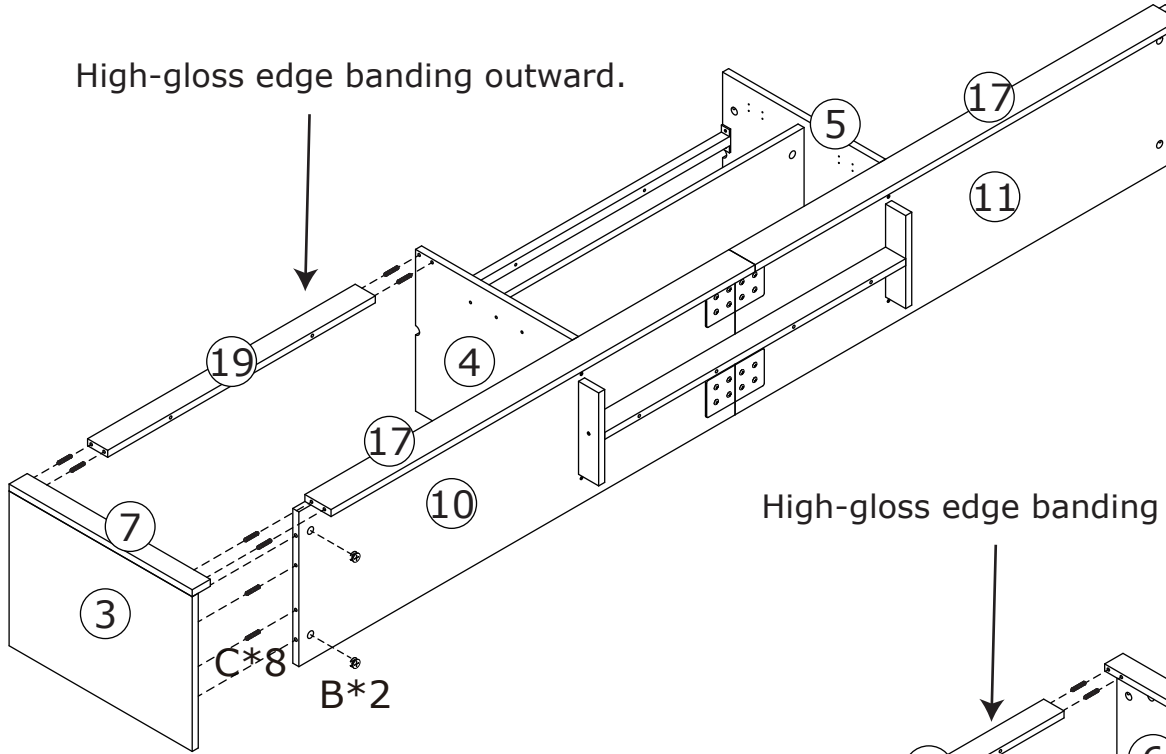

High-gloss edge banding outward.

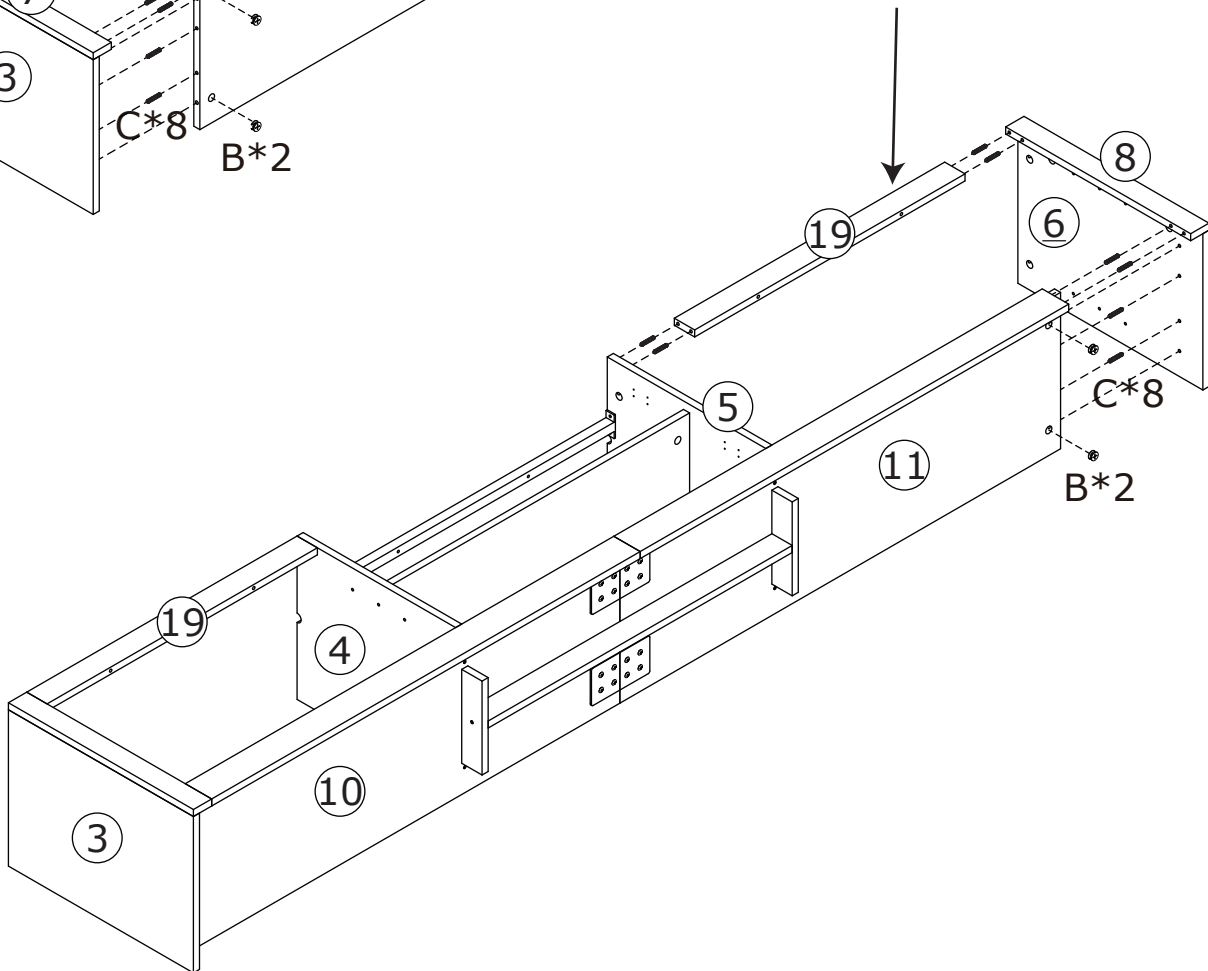

8

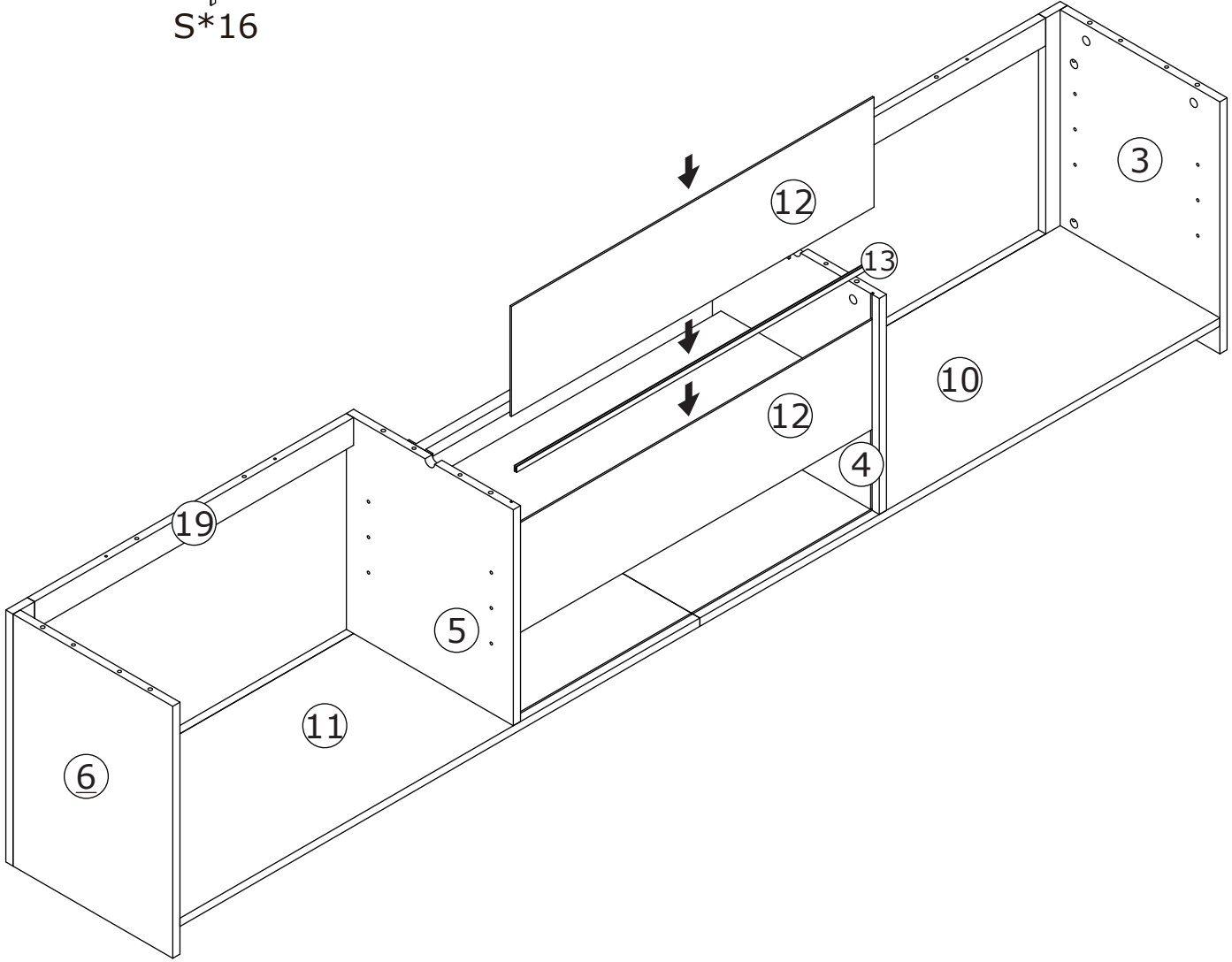
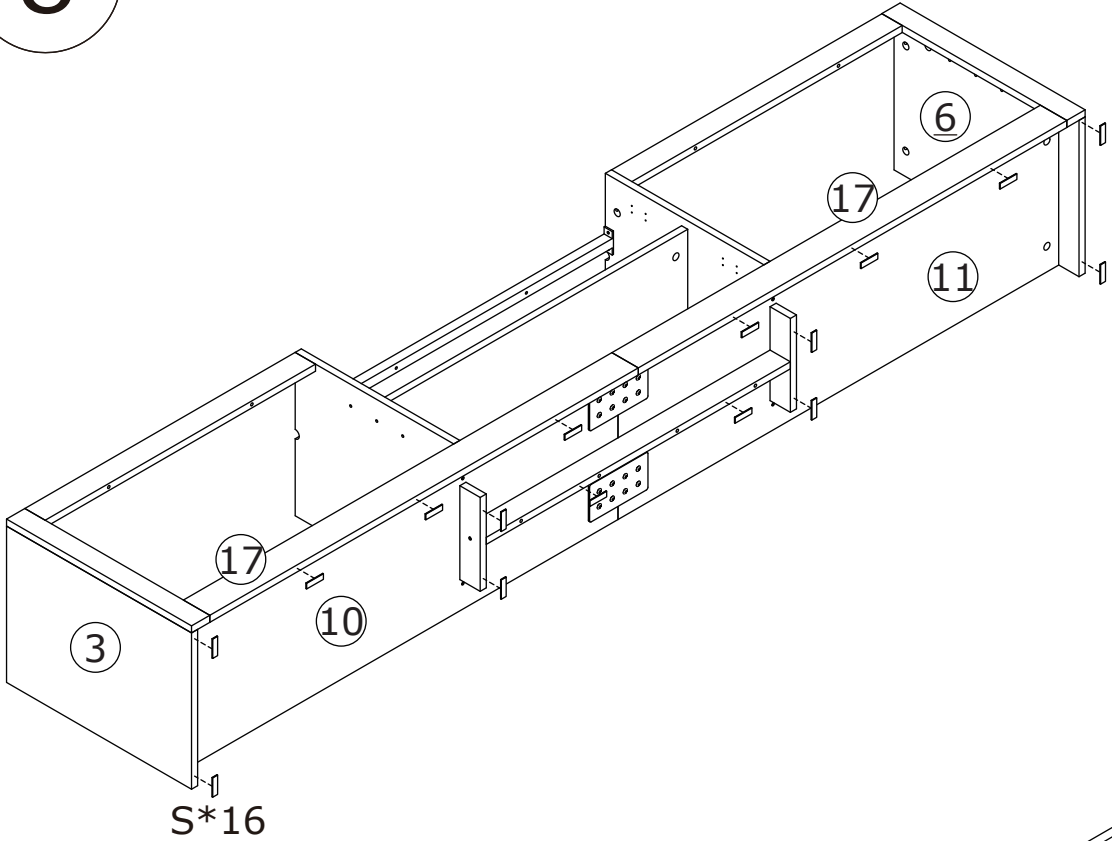
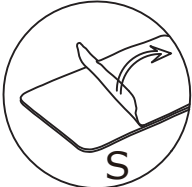
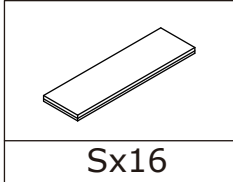

9

Tear off the film of plates 1 and 2 before assembly.

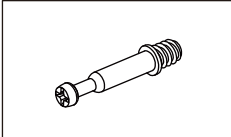
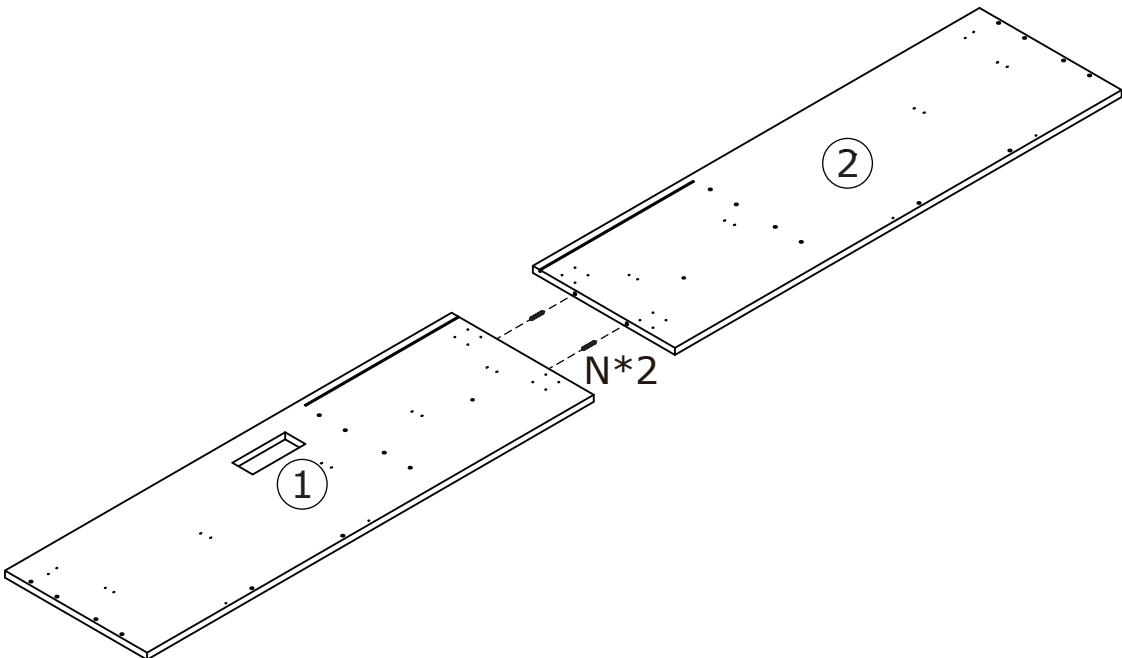

Ax8

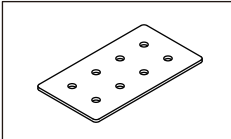

Ux2

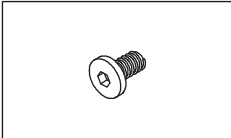

Vx16

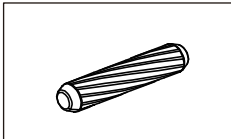

Nx2

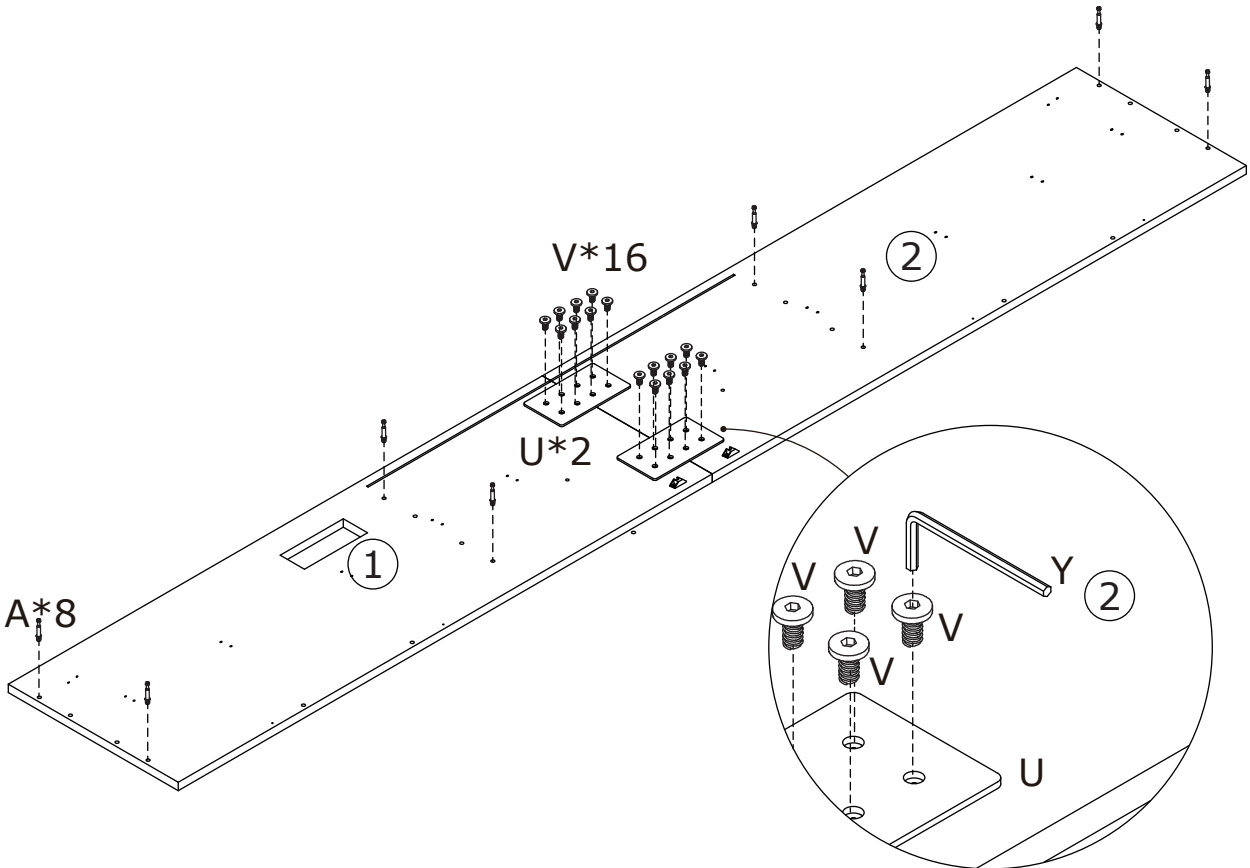

10

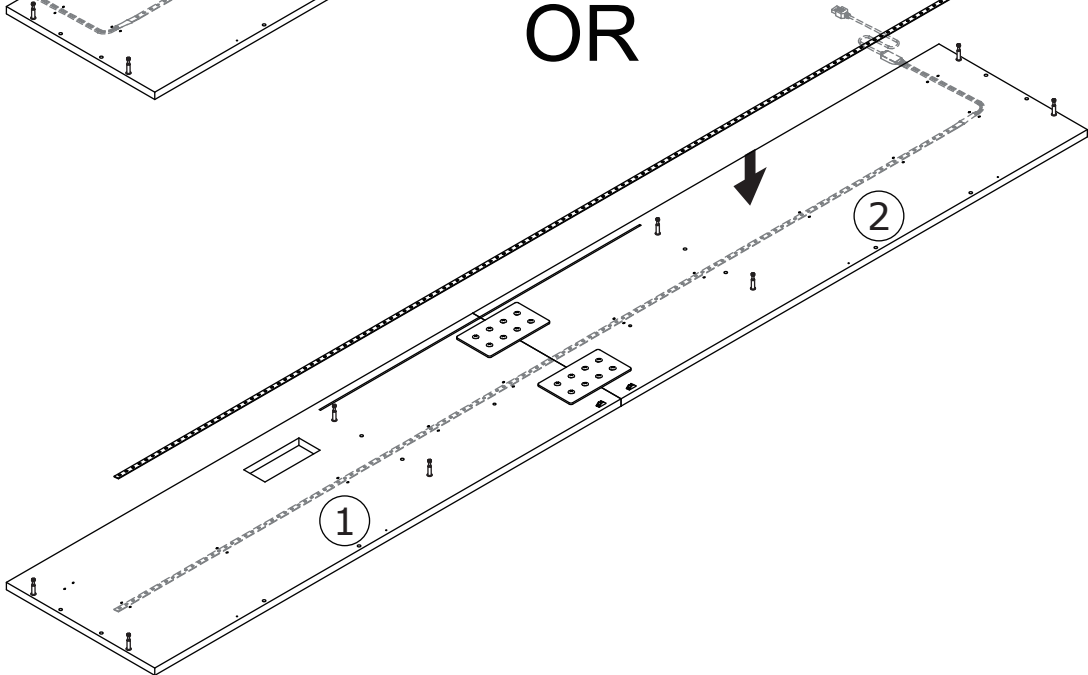
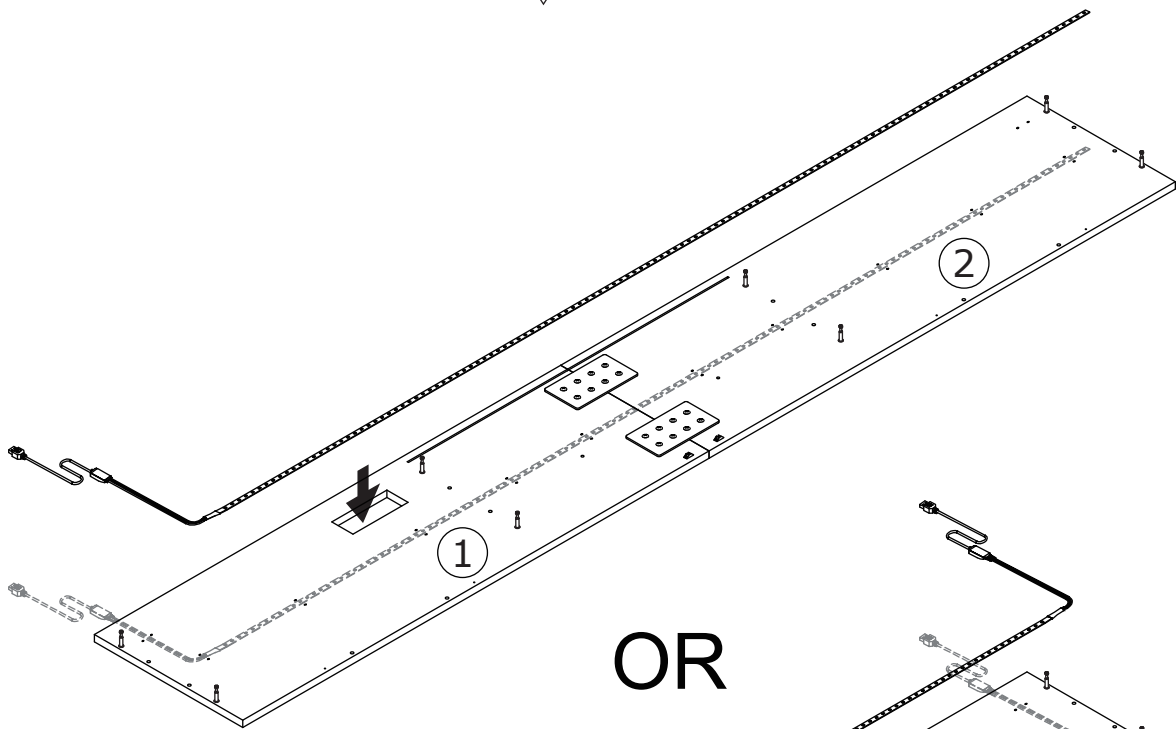
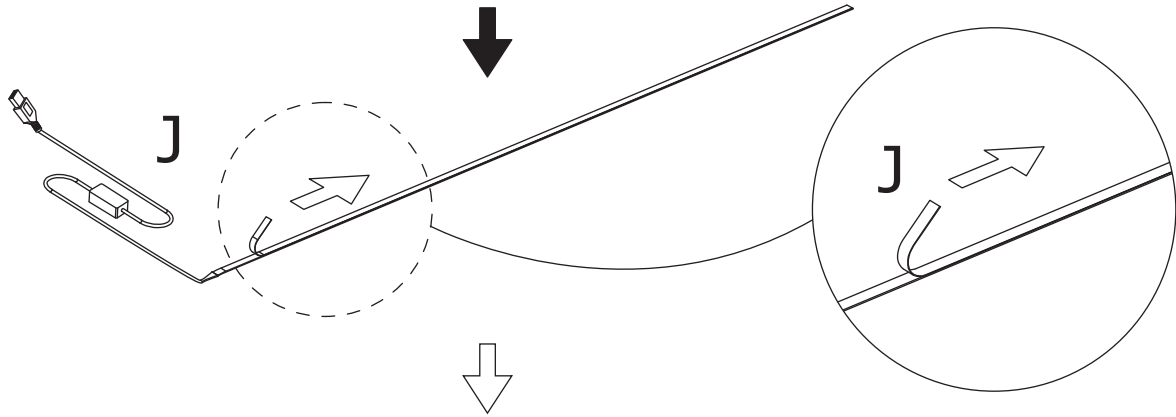
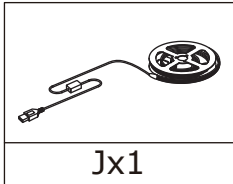
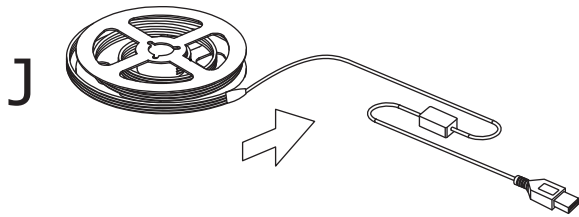

11

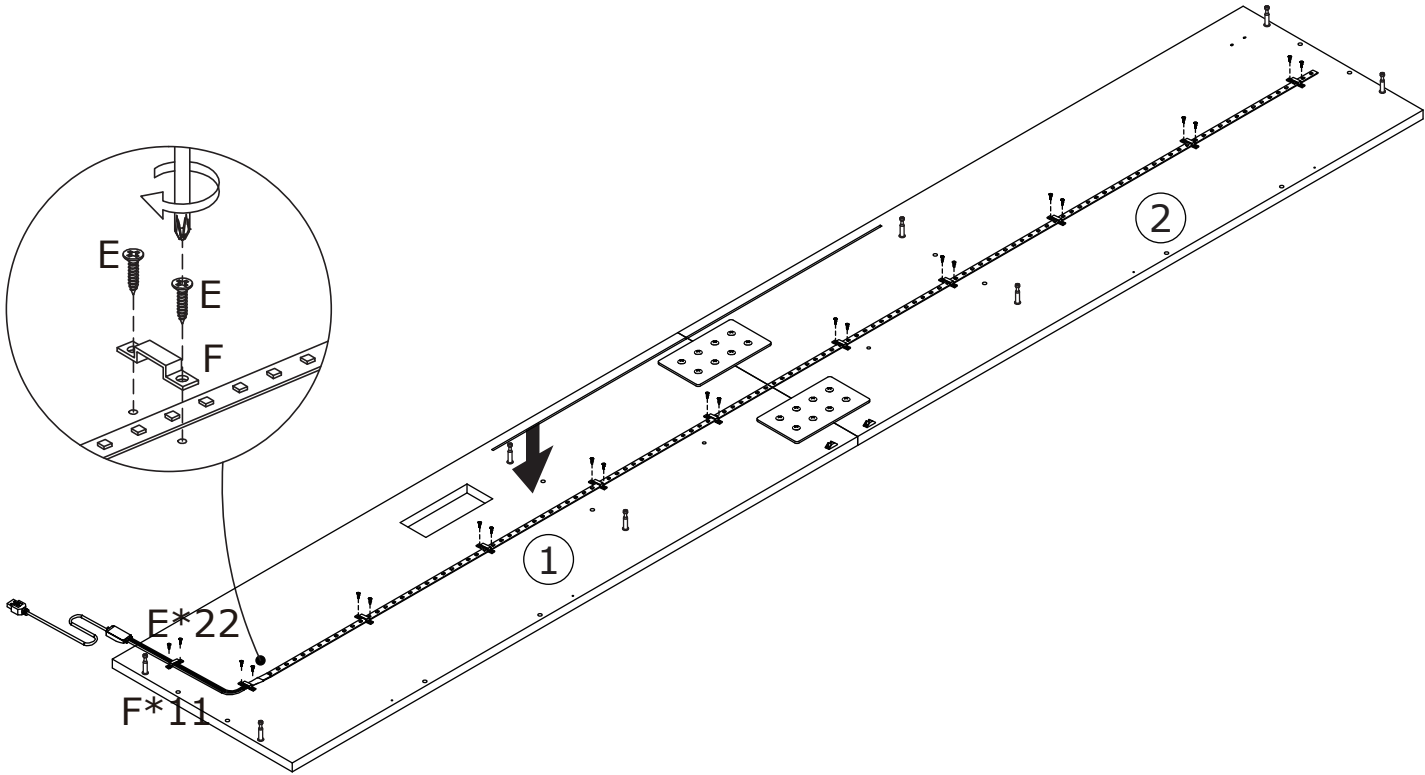
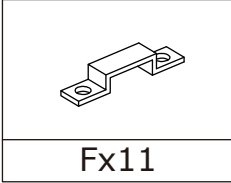
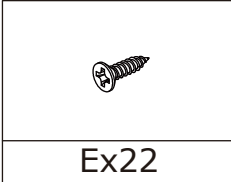

12

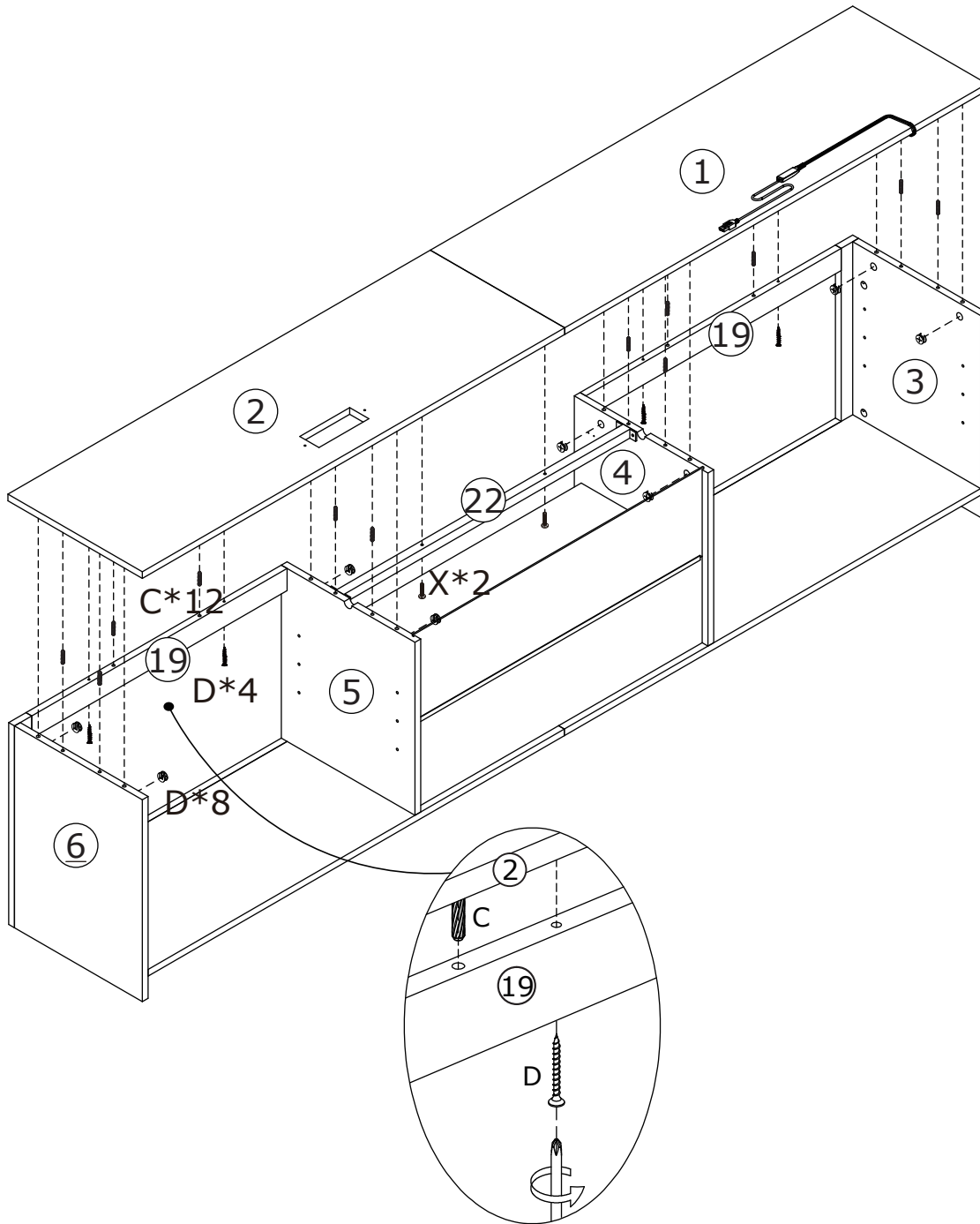
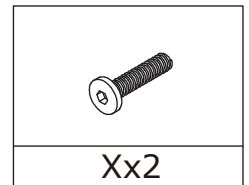
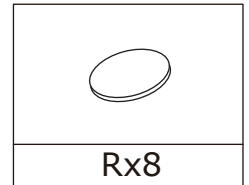
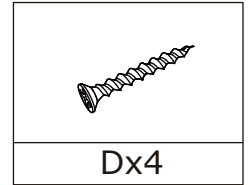
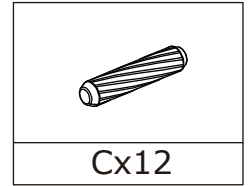
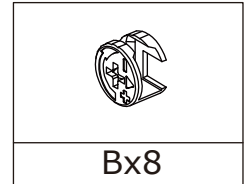
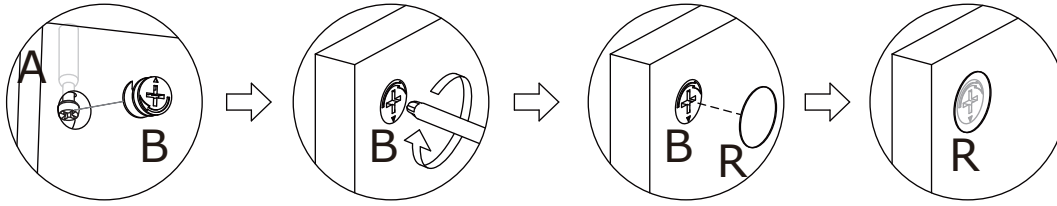

13

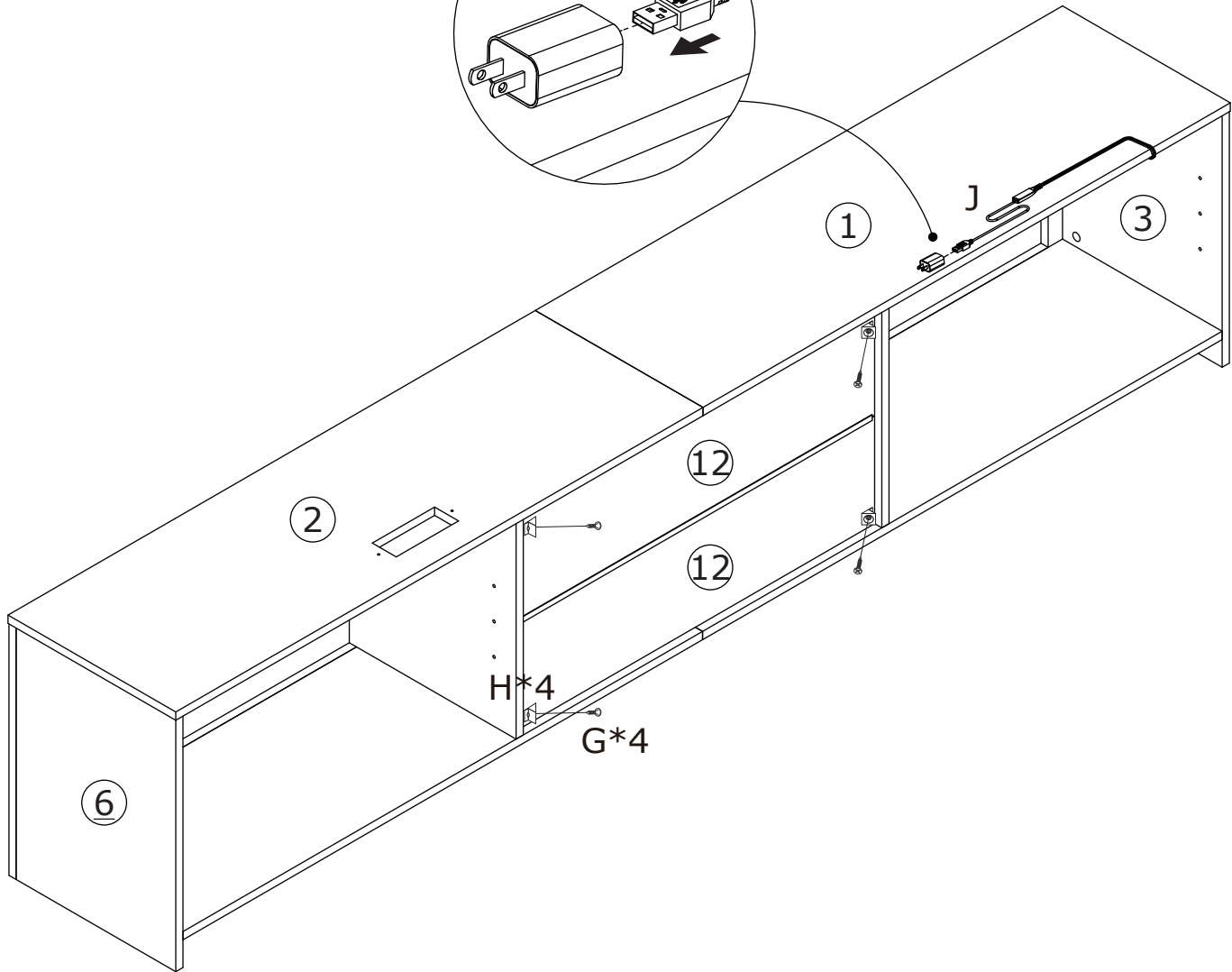
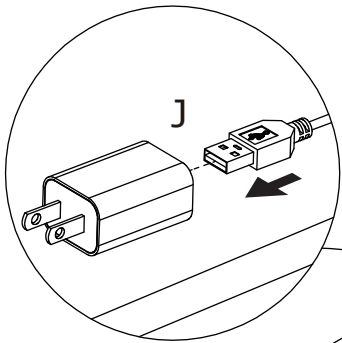
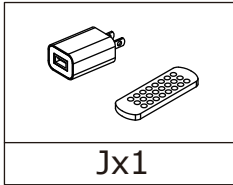
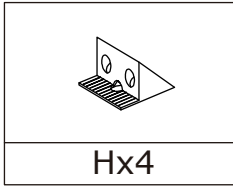
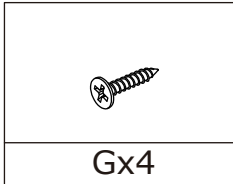

14

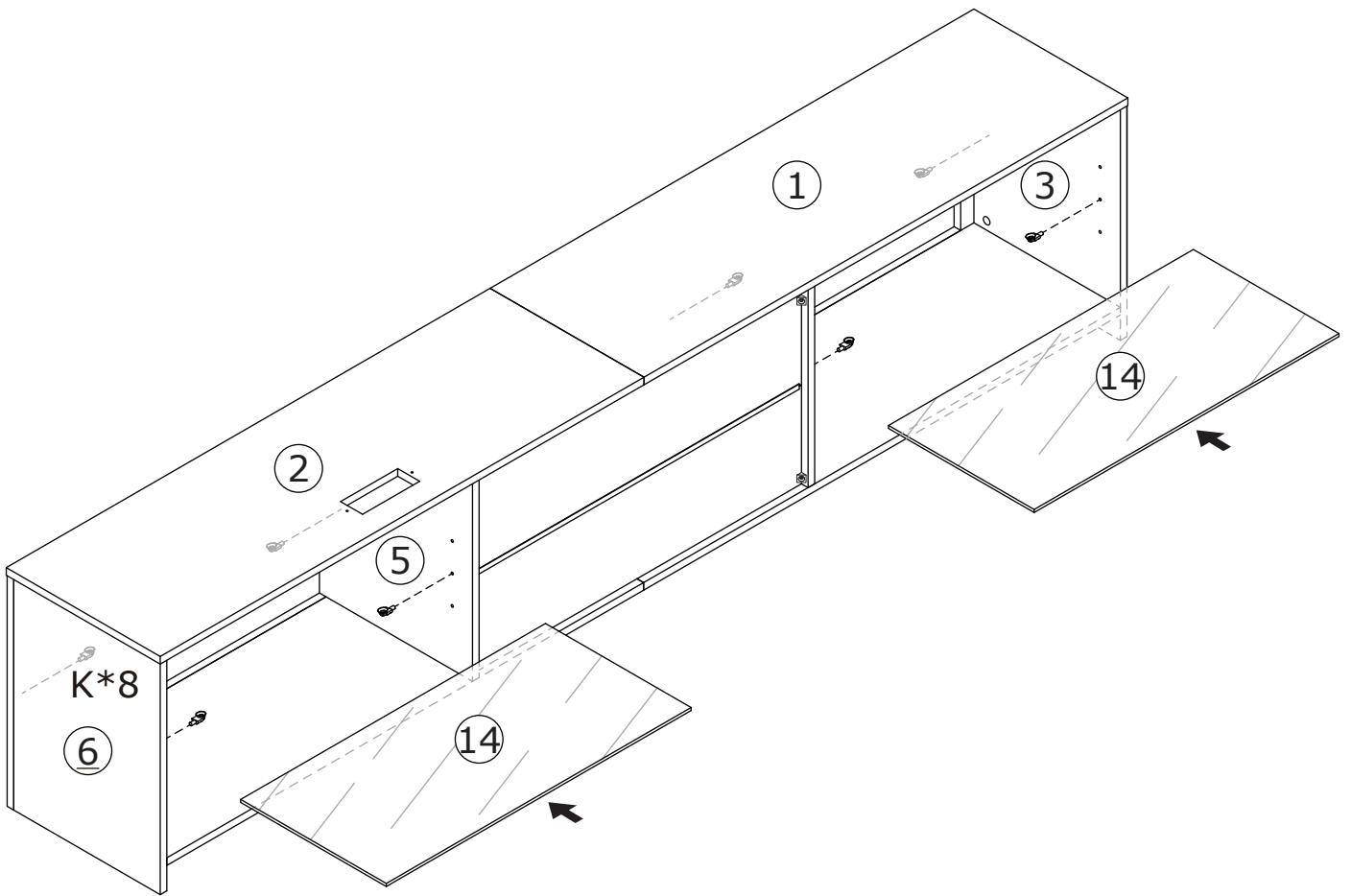
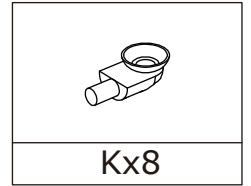

15

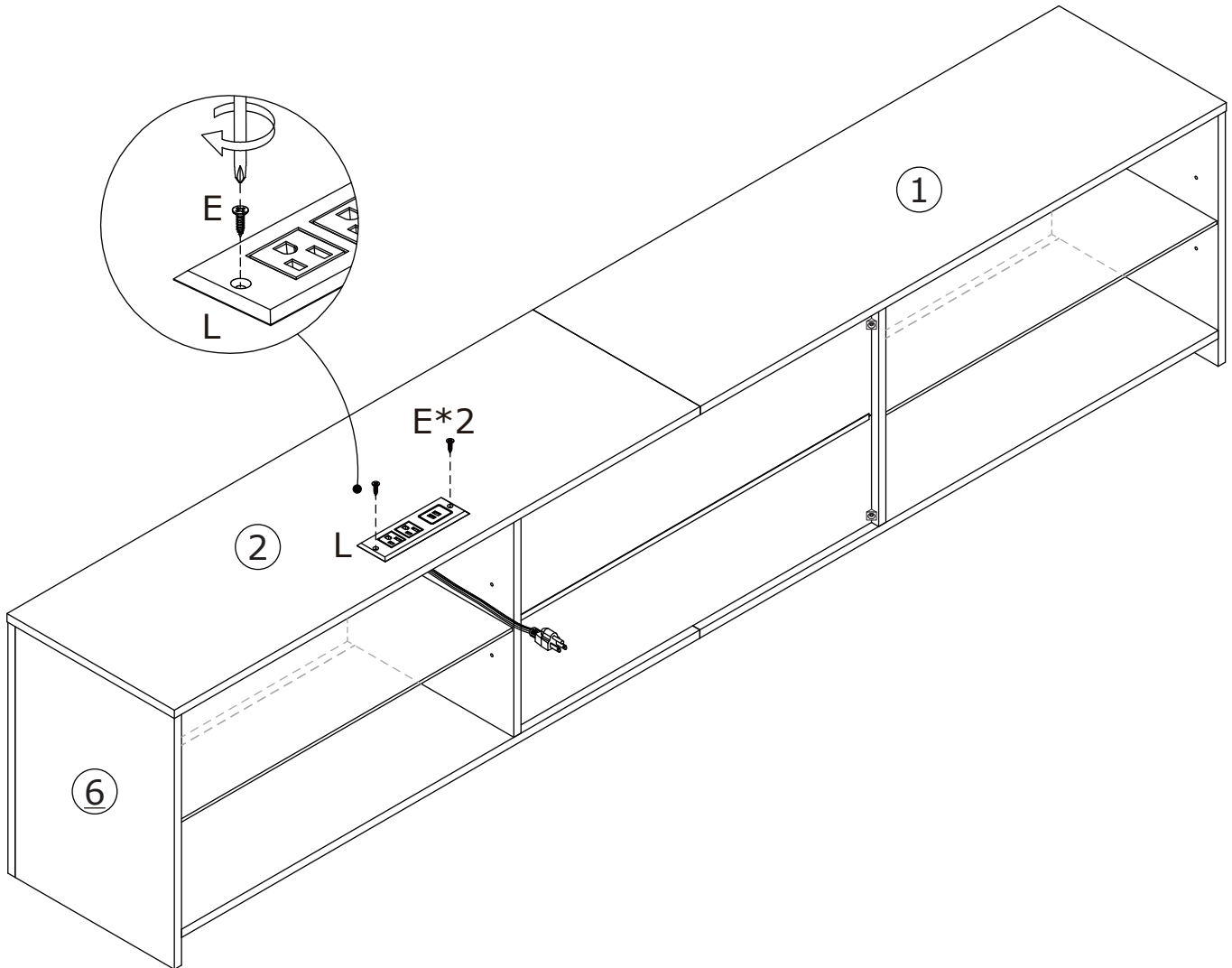
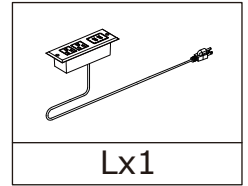
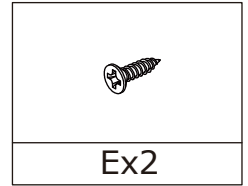

16

Tear off the film of plates 18 before assembly.

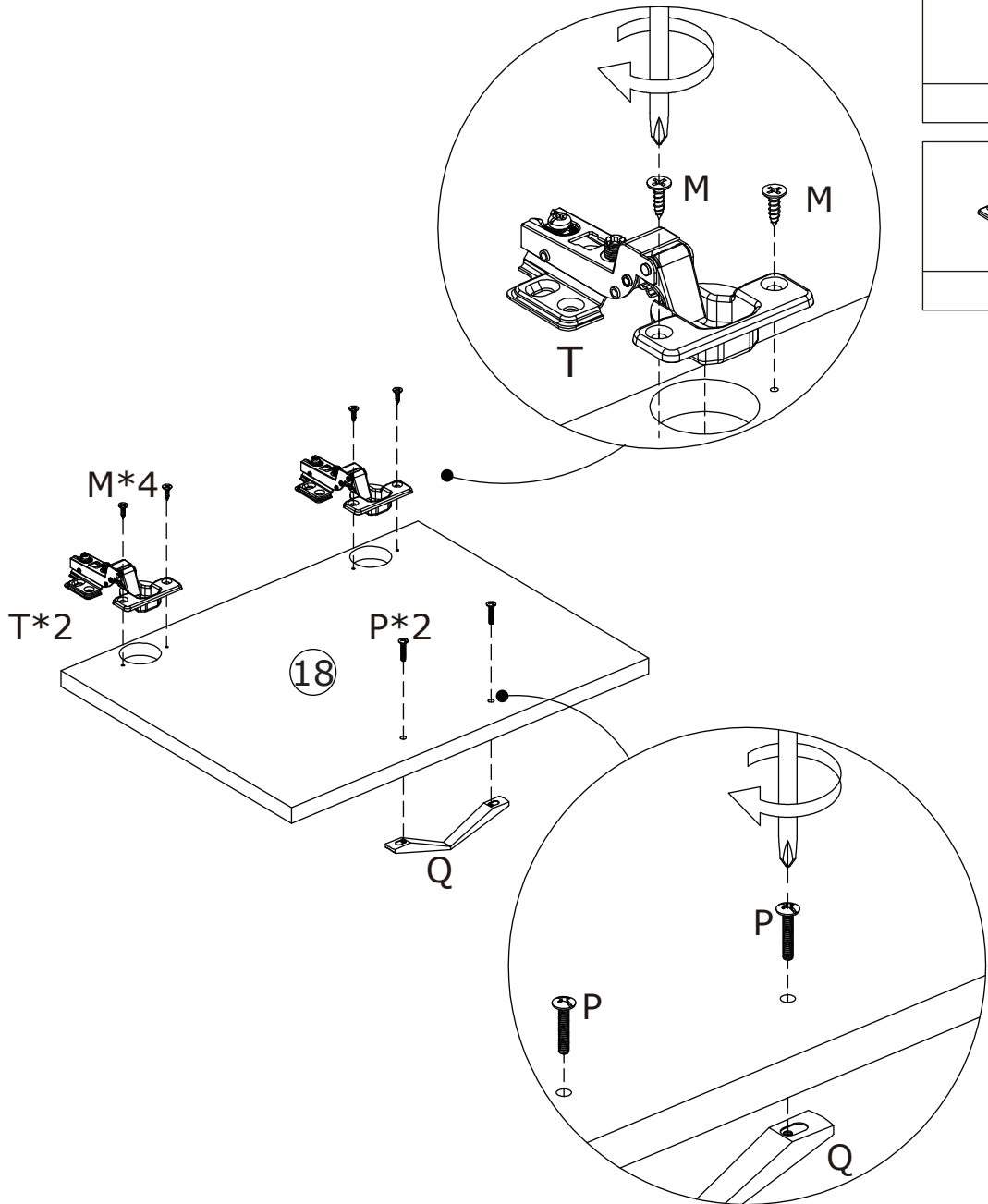
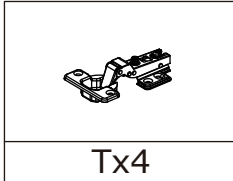
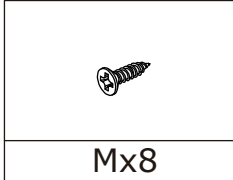
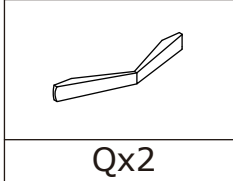
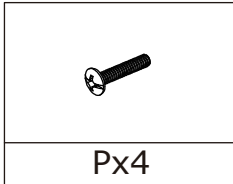

x2

17

