





ASSEMBLY INSTRUCTION

IMPORTANT NOTE :

BEFORE YOU BEGIN, PLEASE AND FOLLOW THE ASSEMBLY INSTRUCTIONS CAREFULLY.

- o IDENTIFY AND SEPARATE ALL PARTS BEFORE DISCARDING PACKAGING.
- o PLACE WOODEN PARTS ON A CLEAN SOFT SURFACE TO AVOID SCRATCHING THE PARTS.
- o DO NOT USE POWER TOOL FOR ASSEMBLY.
- o AS WITH ALL FURNITURE, OCCASIONALLY CHECK TO INSURE HARDWARE IS TIGHT.

PARTS LIST			
NO	DESCRIPTION		QTY
A	TABLE TOP		1 PC
B	PEDESTAL COLUMN		1 PC
C	PEDESTAL LEG		4 PCS
D	MOUNTING RAIL		1 SET

HARDWARE LIST			
NO	DESCRIPTION		QTY
E	HEX NUT		8 PCS
F	SPRING WASHER		8 PCS
G	FLAT WASHER (BIG)		8 PCS
H	WRENCH		1 PC
I	AJUSTABLE		4 PCS
J	JCBC BOLT		4 PCS
K	ALLEN KEY		1 PC
L	WOOD SCREW		16 PCS
M	FLAT WASHER (SMALL)		16 PCS

STEP 1

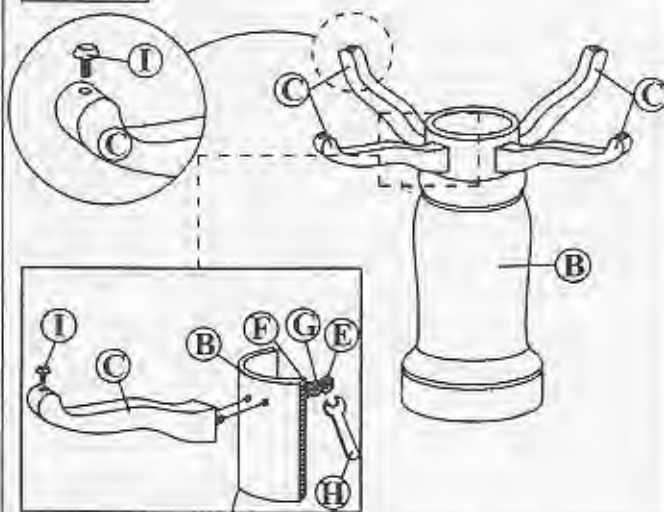

STEP 2

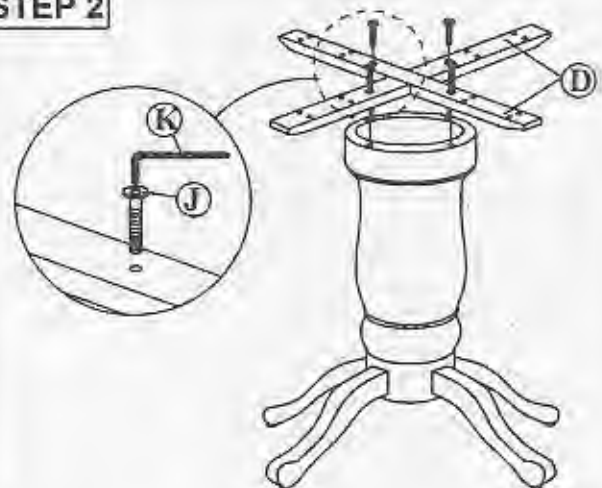

STEP 3

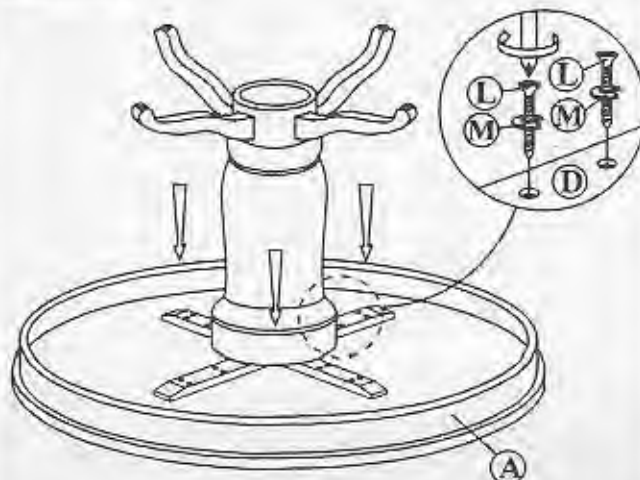





STEP 4





ASSEMBLY INSTRUCTION

No	Part List	Qty
A	Chair Back	1
B	Legs Frame	2
C	Stretchers (Short)	1
D	Stretchers (Long)	1

No	Hardware List	Qty
E	JCBC Bolt M6 x 50 mm 	2
F	Barrel Nut 	2
G	JCBC Screw M7 x 35mm 	6
H	Allen Key 	1
I	Wood Button 	2

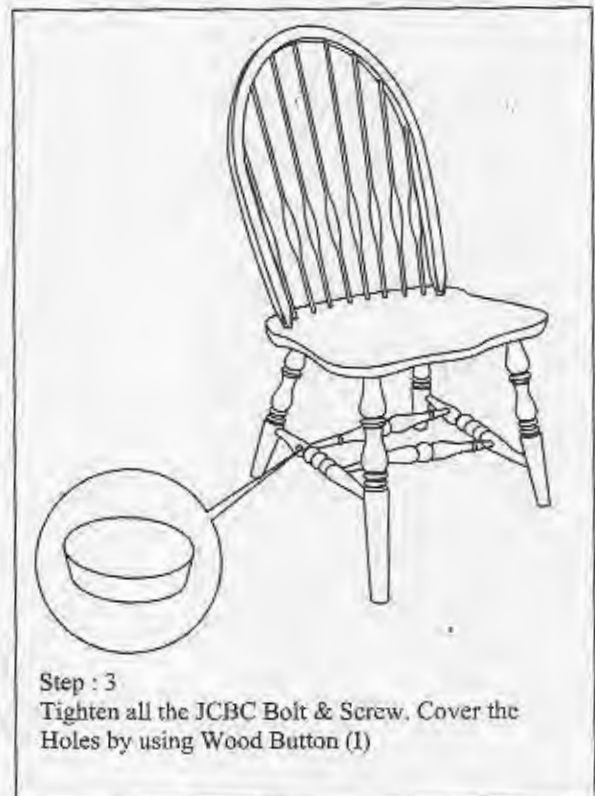
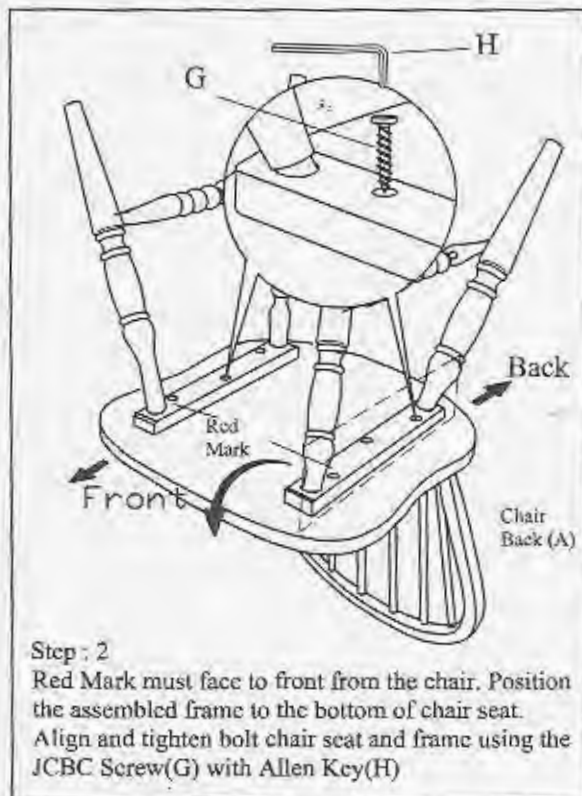
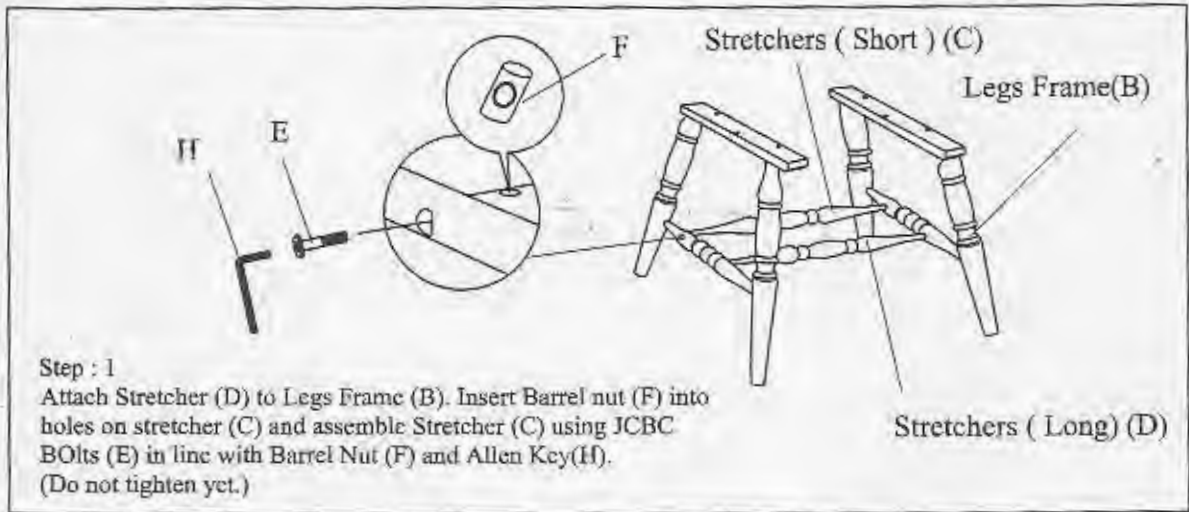

- After a few days of initial assembly and chairs have acclimated to new environment retighten all hardware.



Important Notes