

ASSEMBLY INSTRUCTION

TWIN PLATFORM FRAME

PART LIST:



A:RSF Metal Plate
1PC

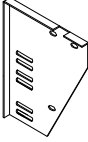

B:LSF Metal Plate
1PC

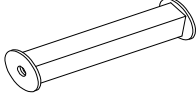

C:Support Tube
2PCS

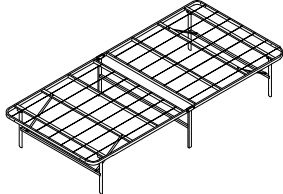

D:Bed Frame
1PC

HARDWARE SET:



E:Bolt
M6*25MM
X 10PCS



F:Bolt
M6*15MM
X 2PCS

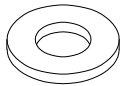

G:Washer
Ø16MM
X 10PCS

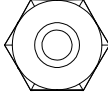

H:Nut
M6
X 4PCS



I:Wing Nut
M6
X 4PCS

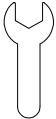

J:Wrench
6MM
X 1PC



K:Allen Key
4MM
X 1PC

STEP 1

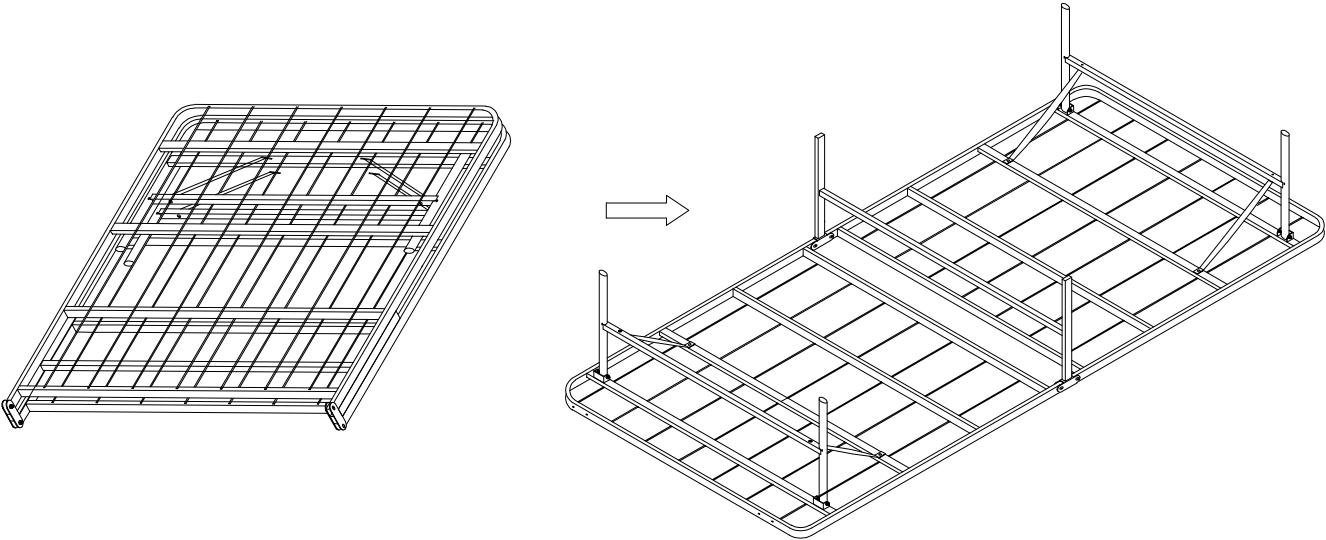

Note: Please do not tighten all bolts until the bed is assembled completely.

STEP 2

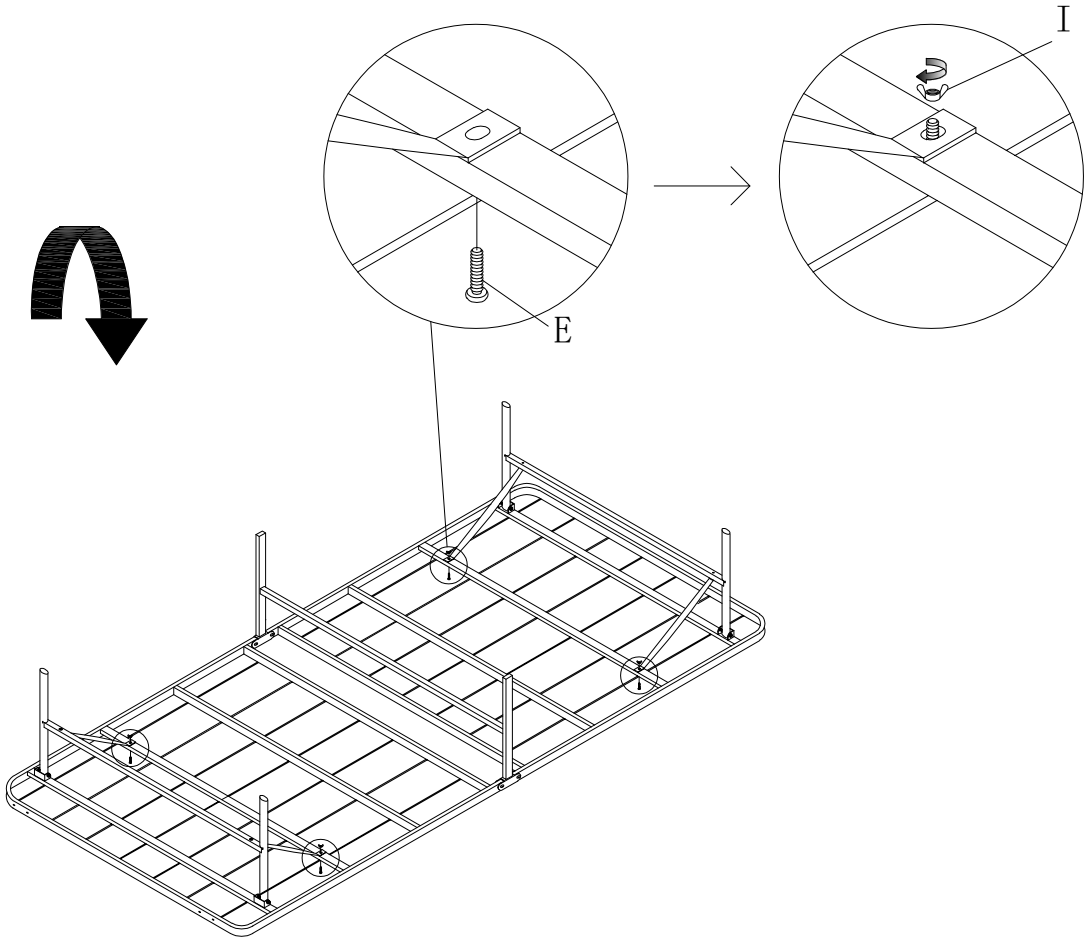

Hardware E: 4 pcs
Hardware I: 4 pcs

STEP 3

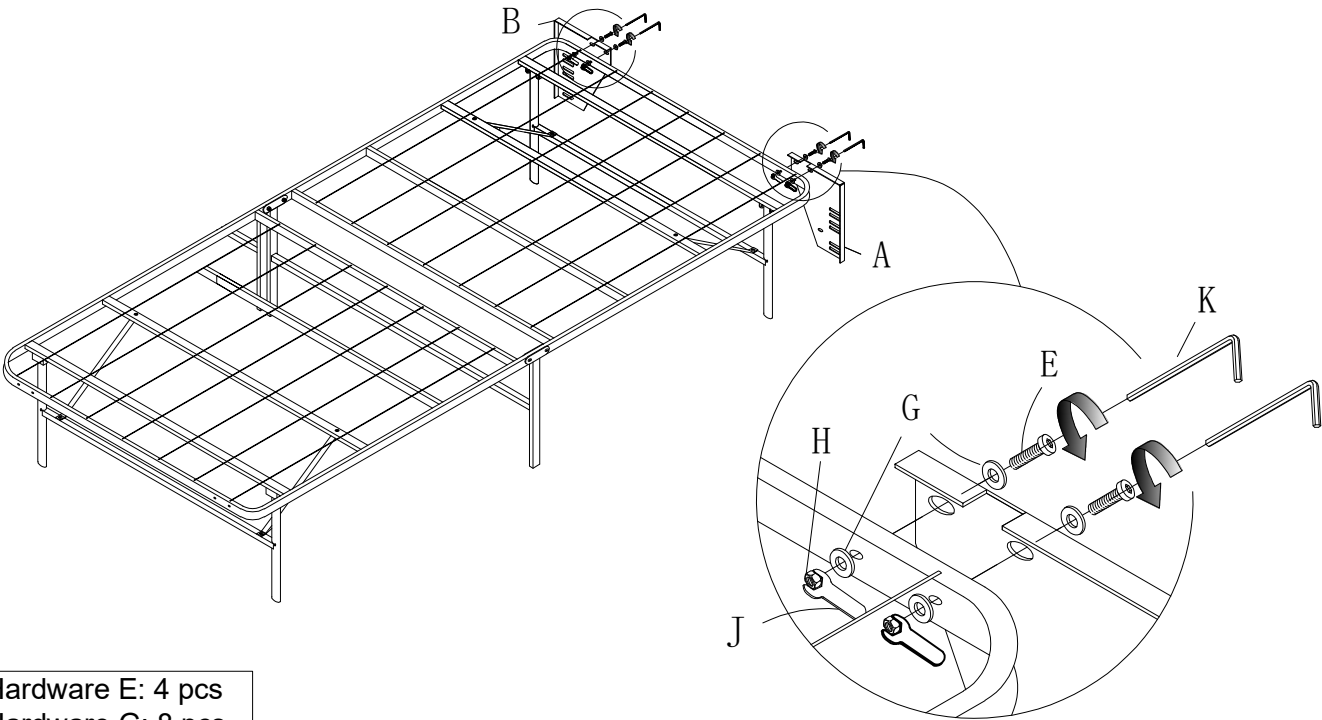

Hardware E: 4 pcs
Hardware G: 8 pcs
Hardware H: 4 pcs

STEP 4

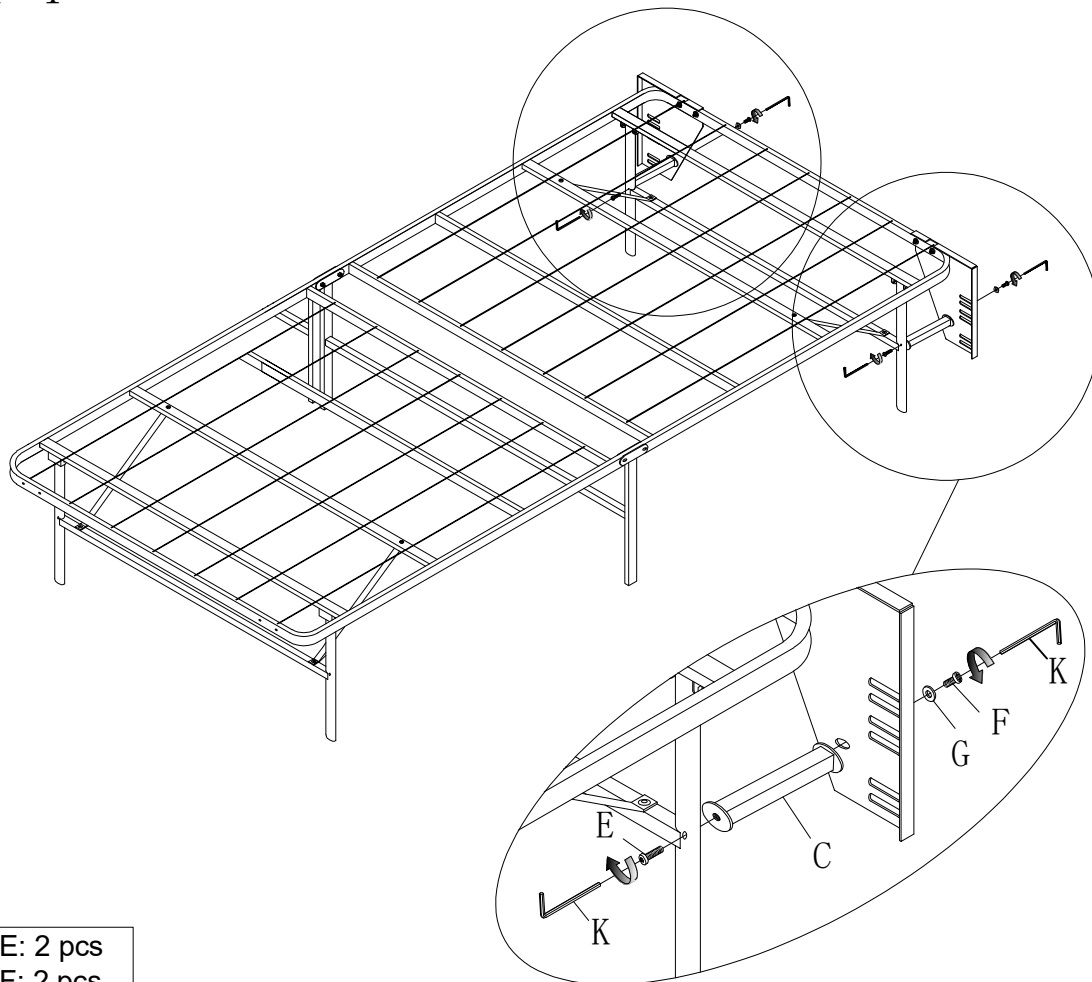

Hardware E: 2 pcs
Hardware F: 2 pcs
Hardware G: 2 pcs

COMPLETED

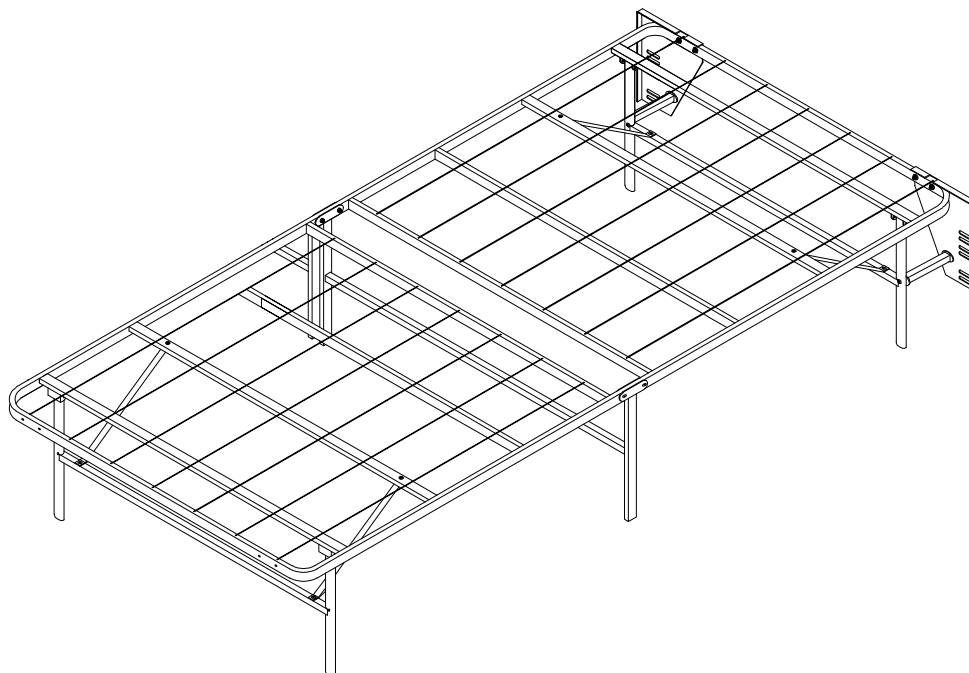

For items use on wooden floor, hard surfaces or carpets, it is recommended to install protective pads under all legs and supports to avoid/prevent from damages/scratches and discoloration.