

# BUFFET CABINET

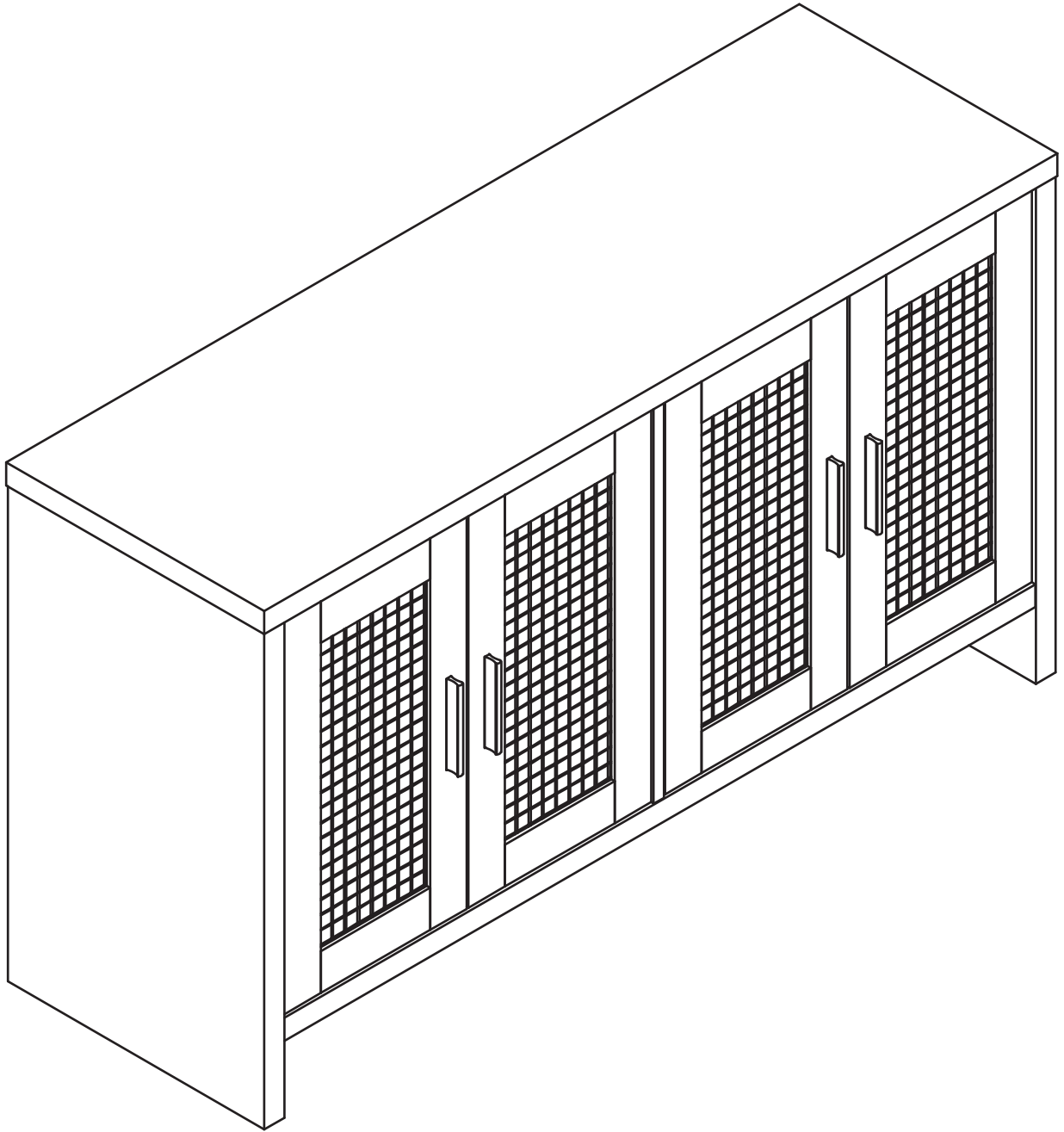

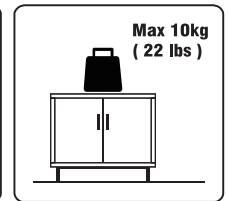
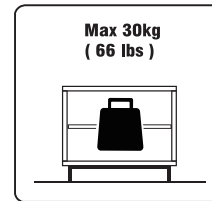
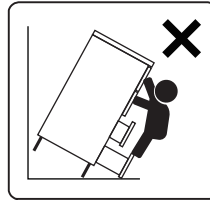
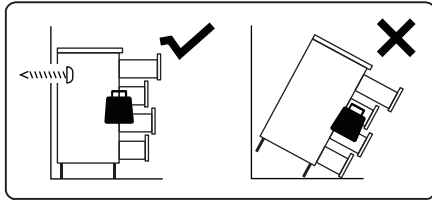
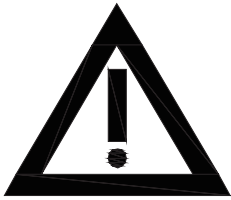

## WARNING (EN)

- During assembly, keep all parts out of children's reach.
- Properly install anti-tipping parts to avoid tipping over caused by uneven weight.
- Climbing can cause injuries to young children.
- Do not sit or stand on the top of the cabinet.

## AVERTISSEMENT (FR)

- Garder toutes les pièces hors de portée des enfants pendant l'assemblage.
- Installer correctement l'ensemble anti-bascule pour éviter que l'armoire ne bascule en raison d'un poids inégal.
- Les jeunes enfants peuvent se blesser en grim pant.
- Ne pas s'asseoir ou se tenir debout sur la surface supérieure de l'armoire.

## WARNUNG (DE)

- Halten Sie während der Montage alle Teile außerhalb der Reichweite von Kindern.
- Installieren Sie die Kippsicherung korrekt, um ein Umkippen aufgrund ungleichmäßiger Gewichtsverteilung zu vermeiden.
- Klettern kann zu Verletzungen bei kleinen Kindern führen.
- Setzen oder stellen Sie sich nicht auf die Oberseite des Schrank s.

## AVVERTENZE (IT)

- Durante l'assemblaggio, tenere tutti i componenti fuori dalla portata dei bambini.
- Installare correttamente i dispositivi anti-ribaltamento per evitare il rischio di ribaltamento causato da un peso non uniforme.
- Arrampicarsi sul mobile potrebbe causare lesioni ai bambini piccoli.
- Non sedersi o stare in piedi sulla superficie superiore del mobile.

## AVISO (ES)

- Mantenga todas las piezas fuera del alcance de los niños durante el montaje.
- Instale el montaje anti-vuelco correctamente para evitar que se vuelque debido al peso desigual.
- Trepar puede causar lesiones a los niños pequeños.
- No se siente ni se pare encima de los gabinetes.

## Advice of Use (EN)

- Avoid use in humid environments and keep away from high temperature sources such as stoves, heaters, etc.
- For maximum quality, re-tighten the screws when necessary.
- Wipe clean with a cloth dampened in a mild cleaner, then wipe dry with a clean cloth.

## Mode d'emploi (FR)

- Éviter de l'utiliser dans des environnements humides et le tenir éloigné des sources de chaleur telles que les poêles, les chauffages, etc.
- Resserrer les vis si nécessaire pour maintenir une qualité optimale.
- Essuyer-le avec un chiffon imbibé d'un détergent doux et le sécher avec un chiffon propre.

## Gebrauchsanweisung (DE)

- Vermeiden Sie die Verwendung in feuchten Umgebungen und halten Sie das Produkt von Wärmequellen wie Öfen und Heizgeräten fern.
- Um die beste Qualität zu erhalten, ziehen Sie die Schrauben bei Bedarf nach.
- Wischen Sie das Produkt mit einem Tuch ab, das in eine milde Reinigungslösung getaucht wurde, und trocknen Sie es anschließend mit einem sauberen Tuch ab.

## Indicazioni per l'uso (IT)

- Evitare di utilizzare il prodotto in ambienti umidi e tenerlo lontano da fonti di calore come stufe o radiatori.
- Per mantenere la qualità ottimale, stringere nuovamente le viti se necessario.
- Pulire con un panno imbevuto di detergente delicato e asciugare con un panno pulito.

## Indicaciones de uso (ES)

- Evite el uso en ambientes húmedos y manténgalo alejado de fuentes de alta temperatura como estufas, calefactores, etc.
- Vuelva a apretar los tornillos cuando sea necesario para obtener mejores resultados.
- Limpiar con un paño humedecido con un detergente suave y secar con un paño limpio.

## Assembly Tips (EN)

- Recommend to have 2 people handling product packaging and complete the assembly.
- Make sure all parts in the product package match up with items listed in the parts list.
- Handle with care, place and assemble parts on a clean, flat and soft surface (such as carpet) to prevent them from being scratched.
- Fully tighten the screws after all parts are fitted in position.
- Improper use of the electric screwdriver may cause damage to the product parts.

## Conseils d'assemblage (FR)

- Il est recommandé que deux personnes transportent le produit et procèdent à l'assemblage.
- S'assurer que tous les éléments de l'emballage du produit correspondent à ceux indiqués dans la liste des pièces.
- Manipuler et assembler les pièces avec précaution, en les posant et en les assemblant sur une surface propre, plane et douce (par exemple, une moquette) afin d'éviter de les rayer.
- Serrer complètement les vis une fois que tous les éléments du panneau sont en place.
- L'utilisation incorrecte d'un tournevis électrique peut endommager les composants du produit.

## Consigli per il montaggio (IT)

- Si consiglia di trasportare il prodotto e completare l'assemblaggio con l'aiuto di due persone.
- Verificare che tutti gli articoli nella confezione corrispondano all'elenco delle parti.
- Maneggiare con cura e posizionare i componenti su una superficie pulita, piana e morbida (ad esempio un tappeto) per evitare graffi.
- Serrare completamente le viti solo dopo che tutti i pannelli sono stati assemblati e posizionati correttamente.
- Un uso improprio di un cacciavite elettrico potrebbe danneggiare le parti del prodotto.

## Montagehinweise (DE)

- Es wird empfohlen, das Produkt von zwei Personen zu transportieren und zu montieren.
- Stellen Sie sicher, dass alle Artikel im Produktpaket mit der in der Teileliste aufgeführten übereinstimmen.
- Behandeln Sie die Teile vorsichtig und platzieren und montieren Sie sie auf einer sauberen, ebenen und weichen Oberfläche (z.B. Teppich), um Kratzer zu vermeiden.
- Ziehen Sie die Schrauben erst vollständig fest, nachdem alle Paneele an ihrem Platz sind.
- Unsachgemäßer Gebrauch eines elektrischen Schraubendrehers kann zu Beschädigungen der Produktteile führen.

## Consejos de montaje (ES)

- Se recomienda que 2 personas transporten el producto y completen el montaje.
- Asegúrese de que todos los elementos del paquete coincidan con lo que figura en la lista de piezas.
- Saque y ensamble con cuidado, colocando las piezas sobre una superficie limpia, plana y suave (como una alfombra) para protegerlas de rayones.
- Después de que todos los componentes del panel estén en su lugar, apriete completamente los tornillos.
- El uso inadecuado de destornilladores eléctricos puede causar daños a los componentes del producto.

Tools required for assembly ( Not included in package.)

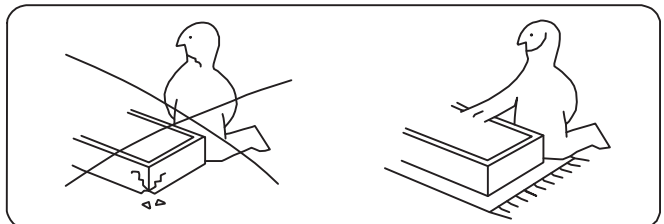
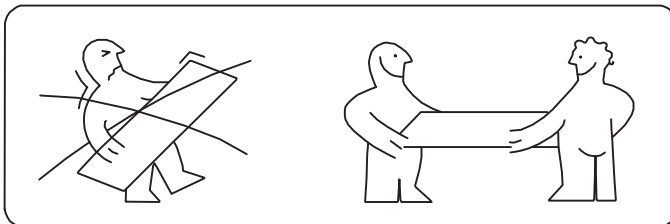
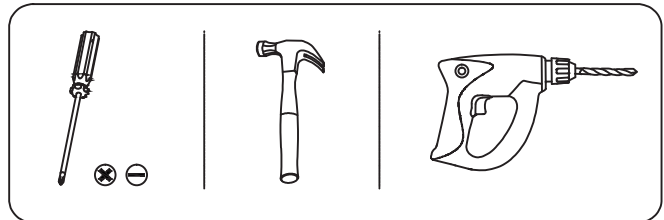

**(EN)**

If the paper version of assembly instructions is not clear enough, you can also refer to the installation video on the product page. If you have any questions about the product, please contact us

**(FR)**

Si la version papier des instructions d'assemblage n'est pas suffisamment claire, vous pouvez également vous référer à la vidéo d'installation sur la page d'information du produit. Si vous avez des questions sur le produit, veuillez nous contacter par l'intermédiaire du QA ou le service e-mail (adresse indiquée ci-dessous).

**(DE)**

Wenn die Papierversion der Montageanleitung nicht deutlich genug ist, können Sie sich auch das Installationsvideo auf der Produktinformationsseite ansehen. Wenn Sie Fragen zum Produkt haben, kontaktieren Sie uns bitte per QA oder Service-E-Mail (Adresse siehe unten).

**(IT)**

Se la versione cartacea delle istruzioni per l'installazione non è sufficientemente chiara, è possibile guardare il video dell'installazione nella pagina delle informazioni sul prodotto. In caso di domande sul prodotto, si prega di contattarci via QA o e-mail di servizio (vedi indirizzo sotto).

**(ES)**

Si la versión impresa de las instrucciones de instalación no es lo suficientemente clara, puede ver el vídeo de instalación en la página de información del producto. Si tiene alguna pregunta sobre el producto, póngase en contacto con nosotros a través de QA o correo electrónico de servicio (ver dirección más abajo).

# Exploded View

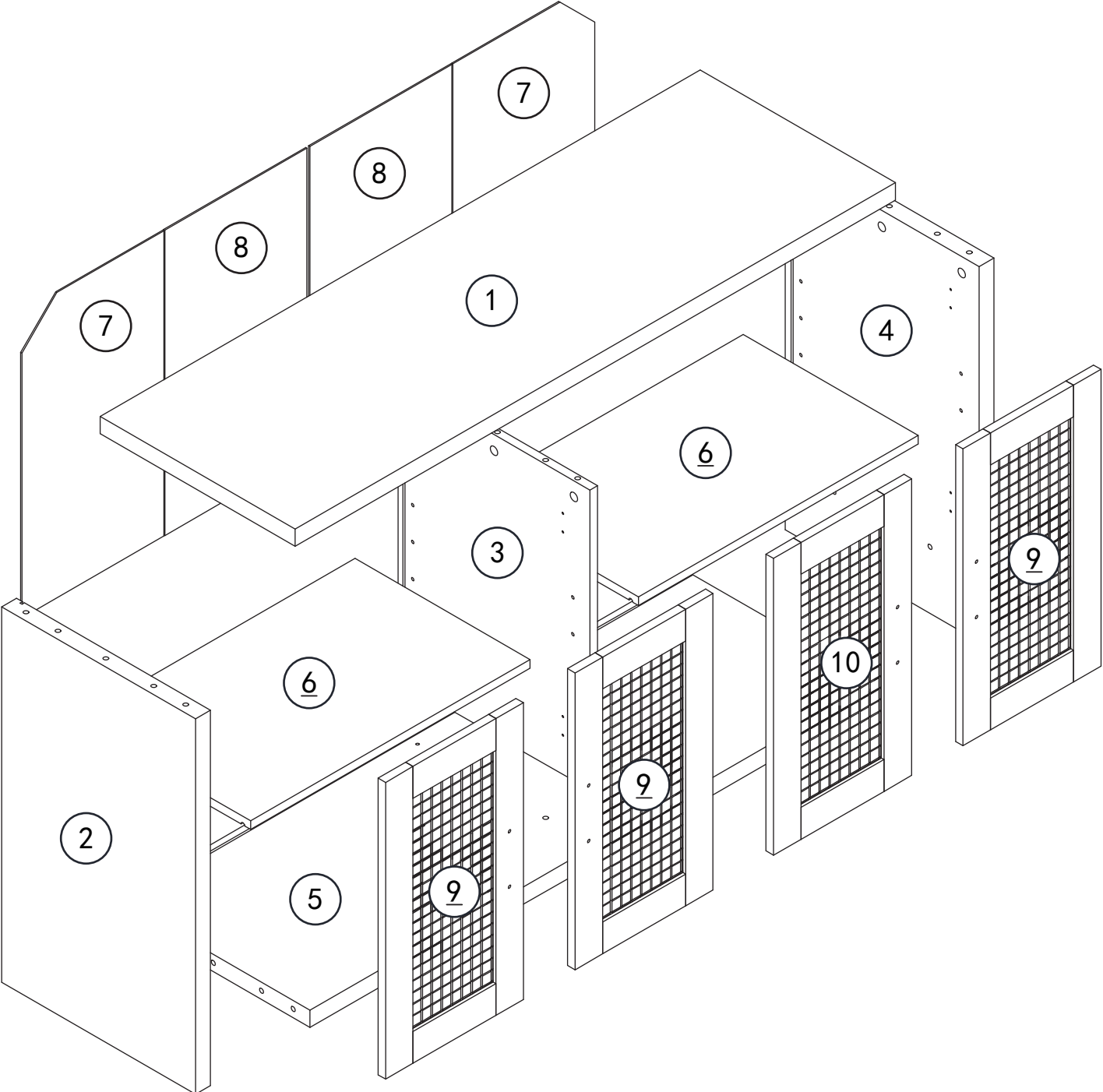

# Parts List

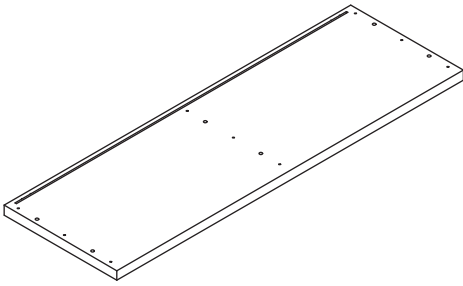

① X1

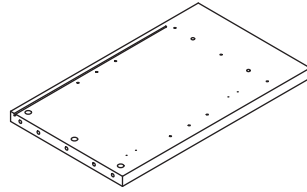

② X1

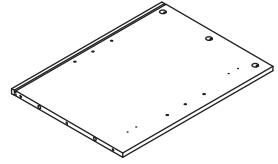

③ X1

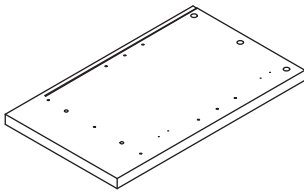

④ X1

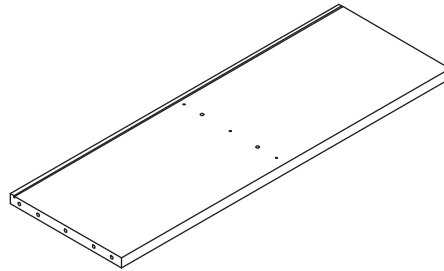

⑤ X1

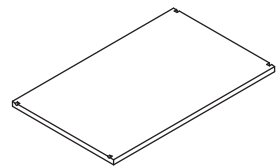

⑥ X2

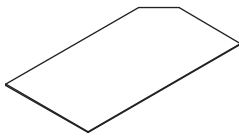

⑦ X2

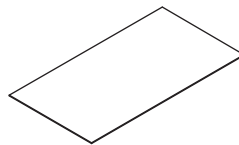

⑧ X2

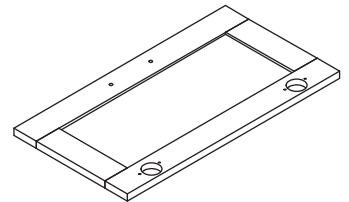

⑨ X3

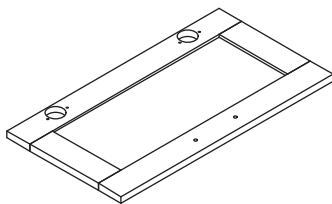

⑩ X1

# Accessories List

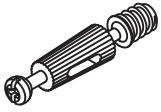

Φ6X35

**A** X15



Φ15X12

**B** X15

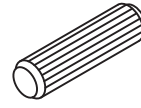

Φ8X30

**C** X12

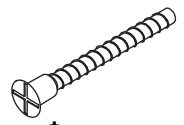

Φ6X50

**D** X3

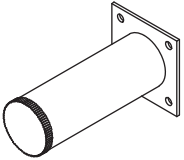

**E** X1

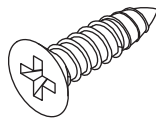

Φ3.5X14

**F** X52

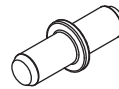

**G** X8



**H** X15

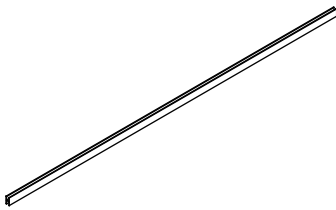

**I** X2

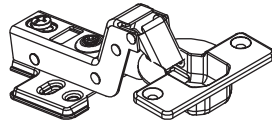

**J** X8

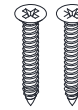

K1



K2

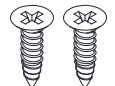

K5



K3

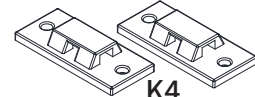

K4

**K** X2

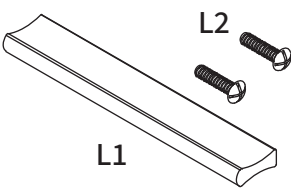

L1

**L** X4

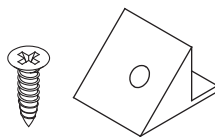

M1

M2

**M** X16



**N** X4

# Proper Use of Accessories

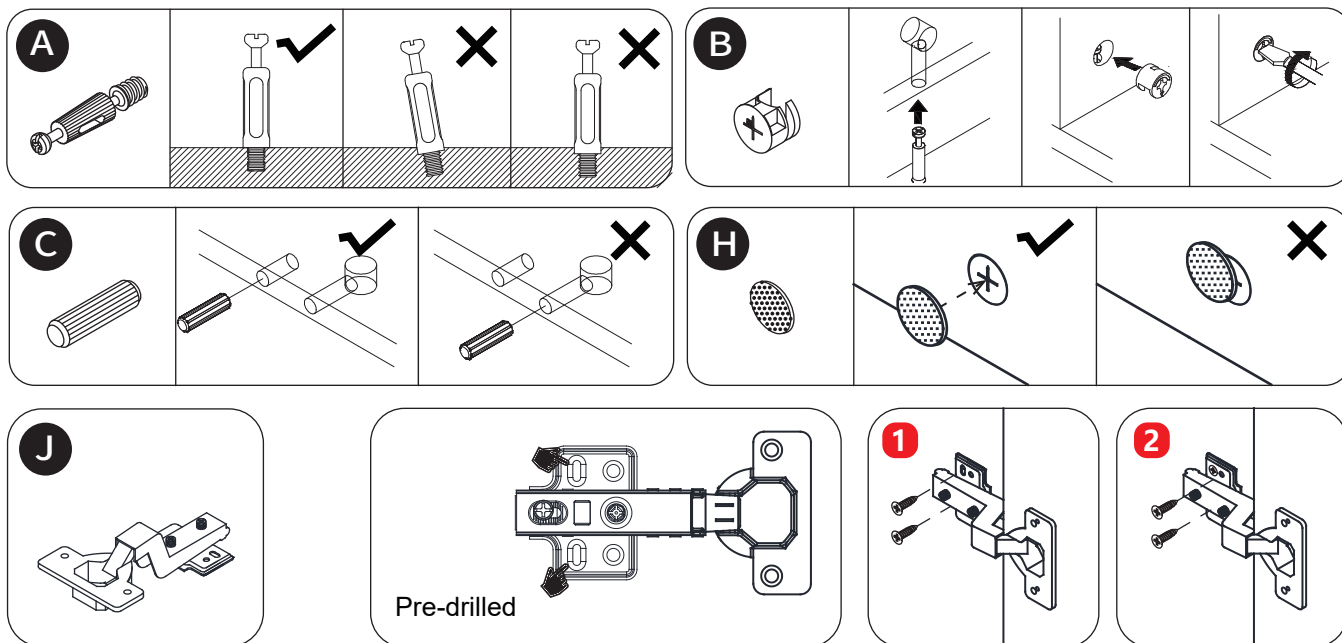

※ (EN)

Hinges can be fixed in position with screws using the 2 pre-drilled holes. After height adjustment, 2 additional screws can make the connection even more secure.

※ (FR)

La charnière peut être fixée à l'aide de vis à travers 2 trous pré-perçés. Une fois la hauteur ajustée, 2 vis supplémentaires peuvent être posées pour renforcer la connexion.

※ (DE)

Die Scharniere können mit zwei vorgebohrten Löchern und Schrauben befestigt werden. Nachdem die Höhe eingestellt ist, können zwei zusätzliche Schrauben angebracht werden, um die Verbindung zu verstärken.

※ (IT)

Le cerniere possono essere fissate utilizzando 2 viti nei fori preforati. Dopo aver regolato l'altezza, è possibile installare altre 2 viti per rendere il collegamento più stabile.

※ (ES)

La bisagra puede fijarse con tornillos a través de 2 orificios pretaladrados. Una vez ajustada la altura, se pueden colocar otros 2 tornillos para reforzar aún más la unión.

# 1

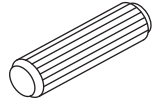

**C** X8

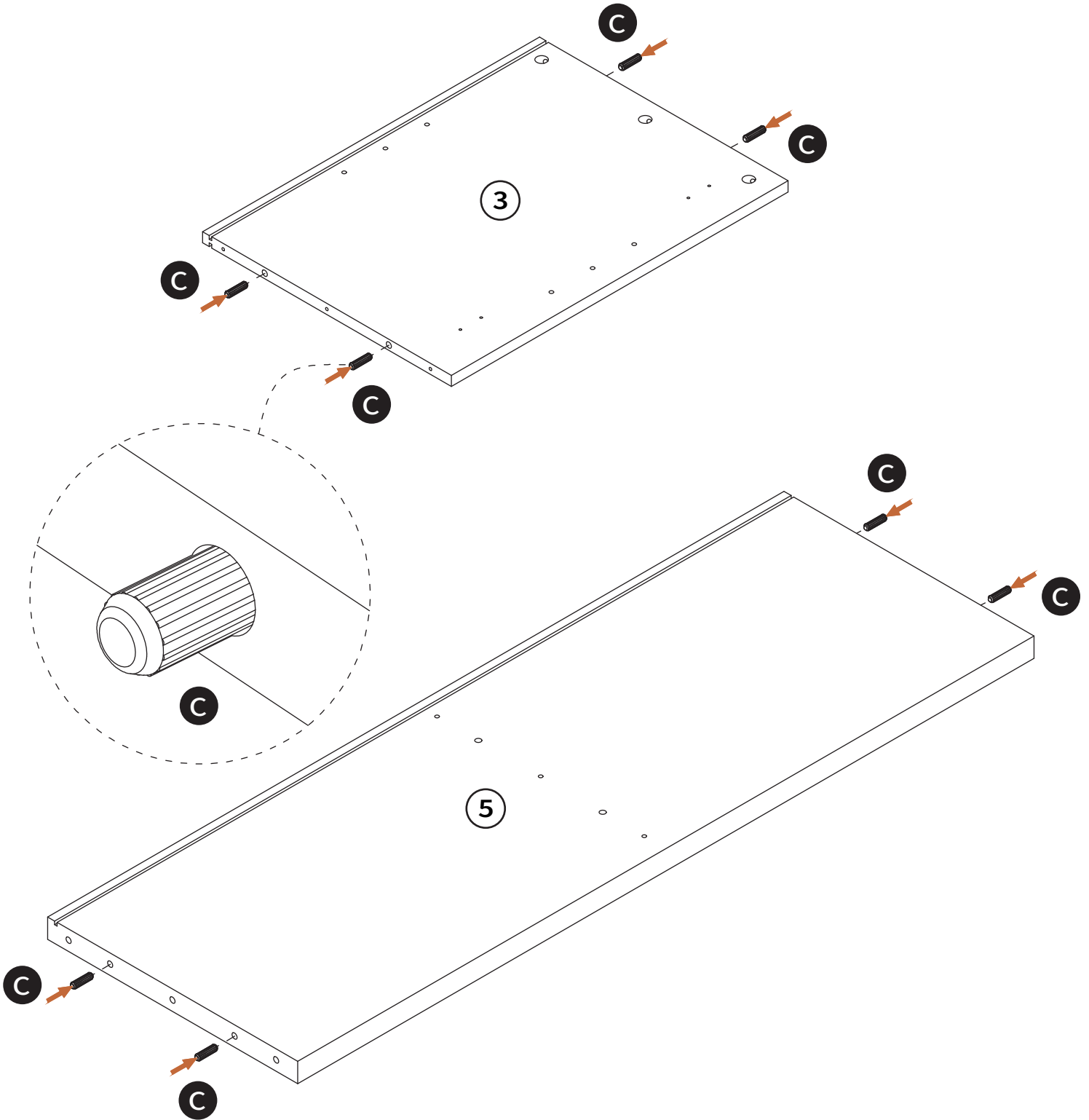

# 2

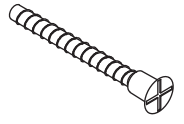

**D** X3

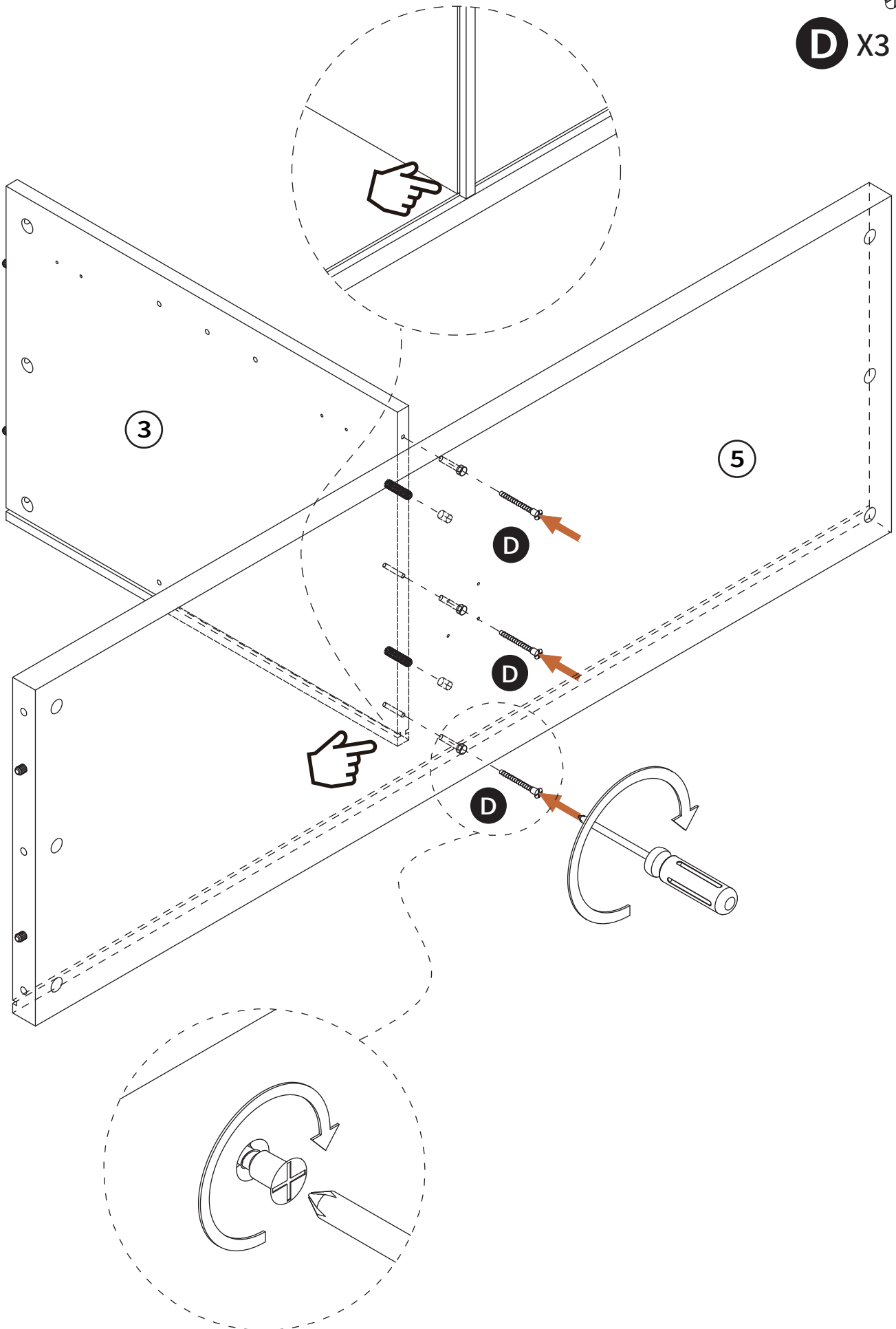

# 3

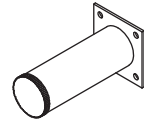

**E** X1

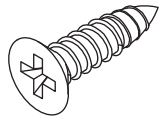

**F** X4

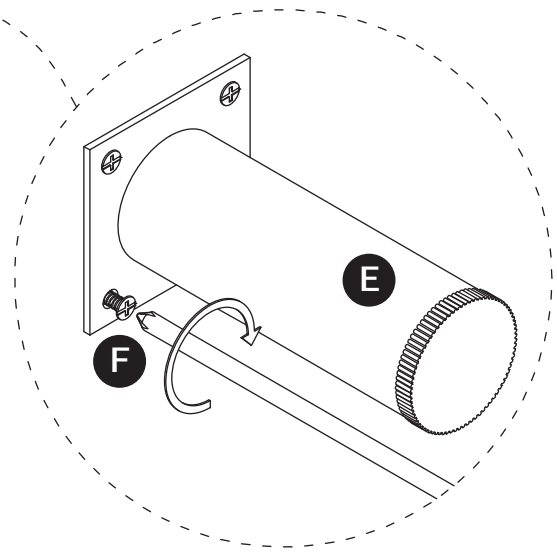
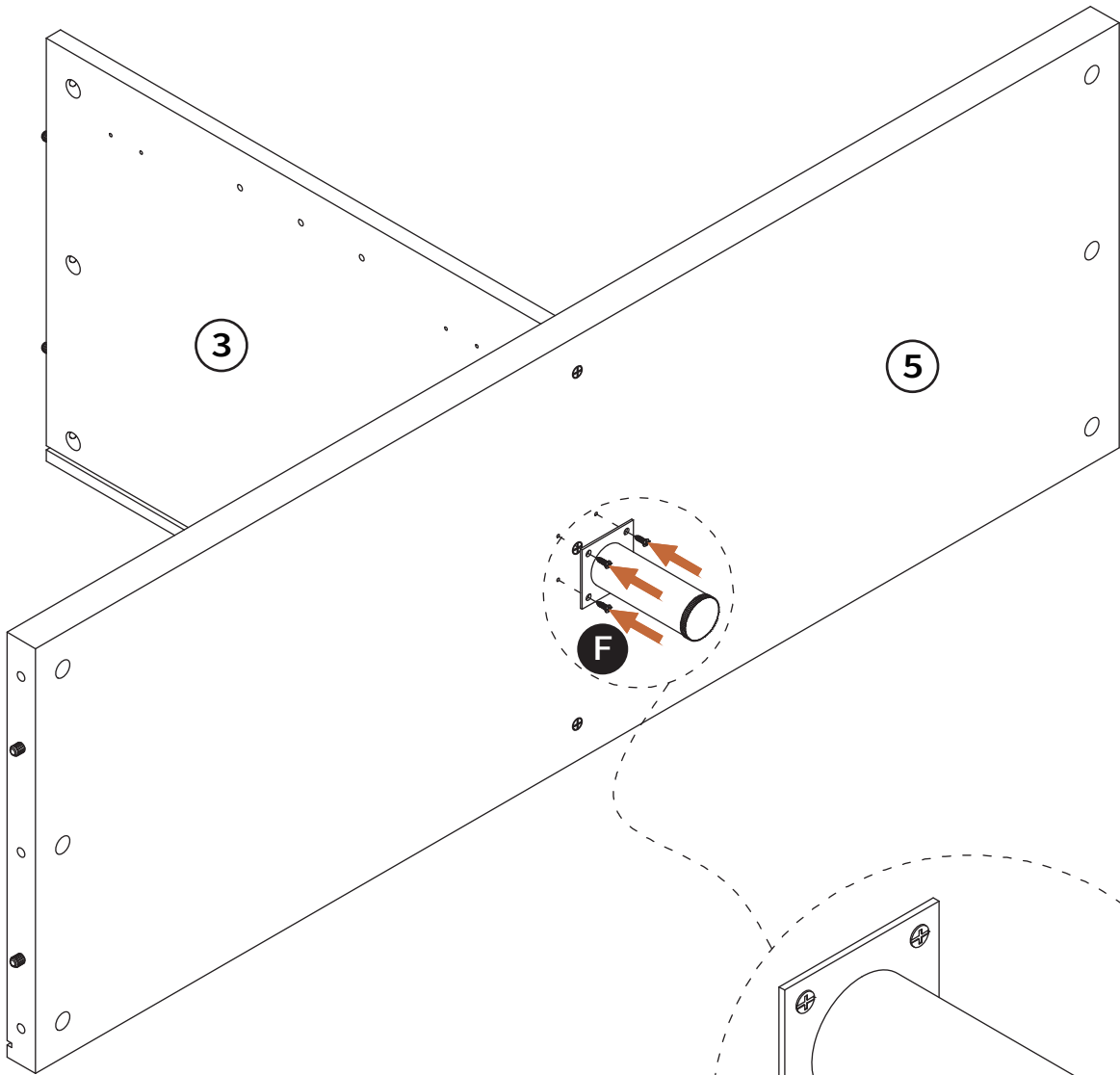

4

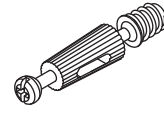

**A** X3

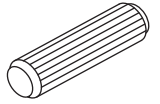

**C** X2

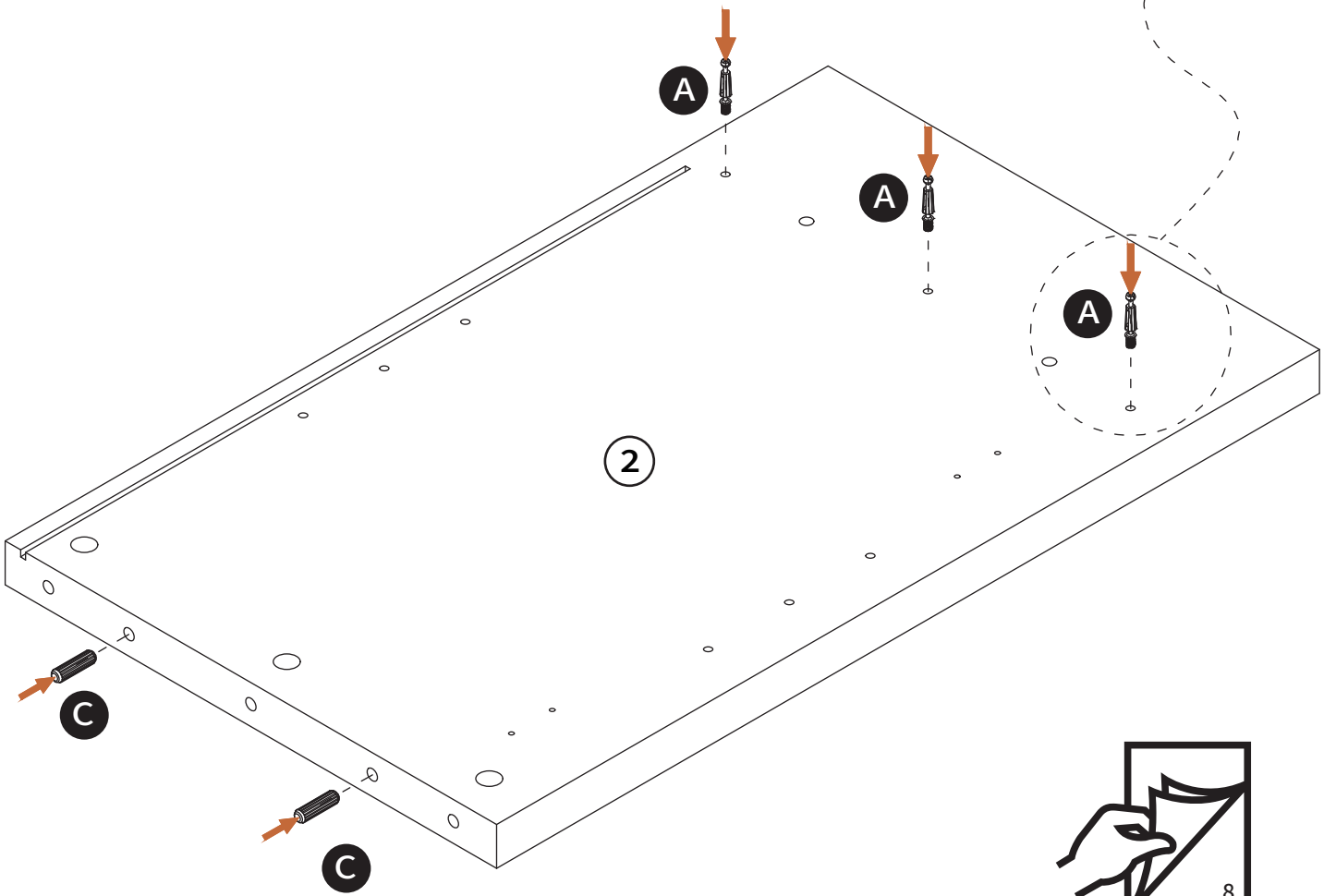
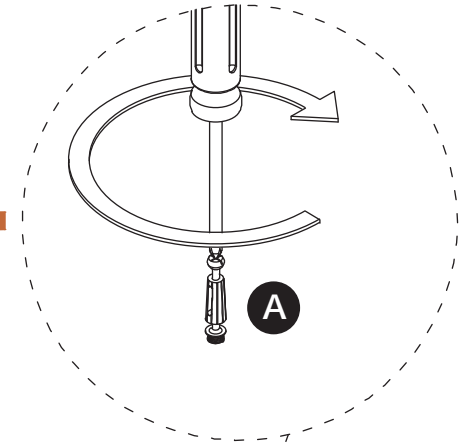
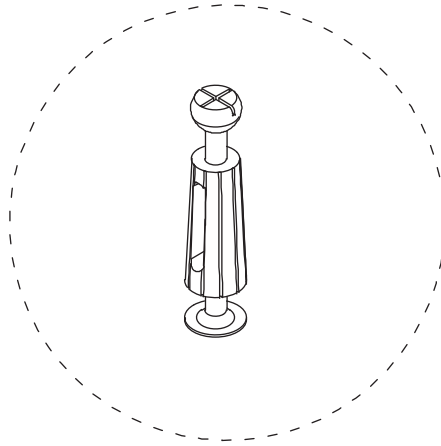

# 5

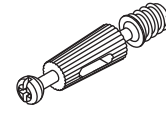

**A** X3

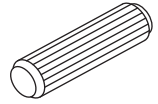

**C** X2

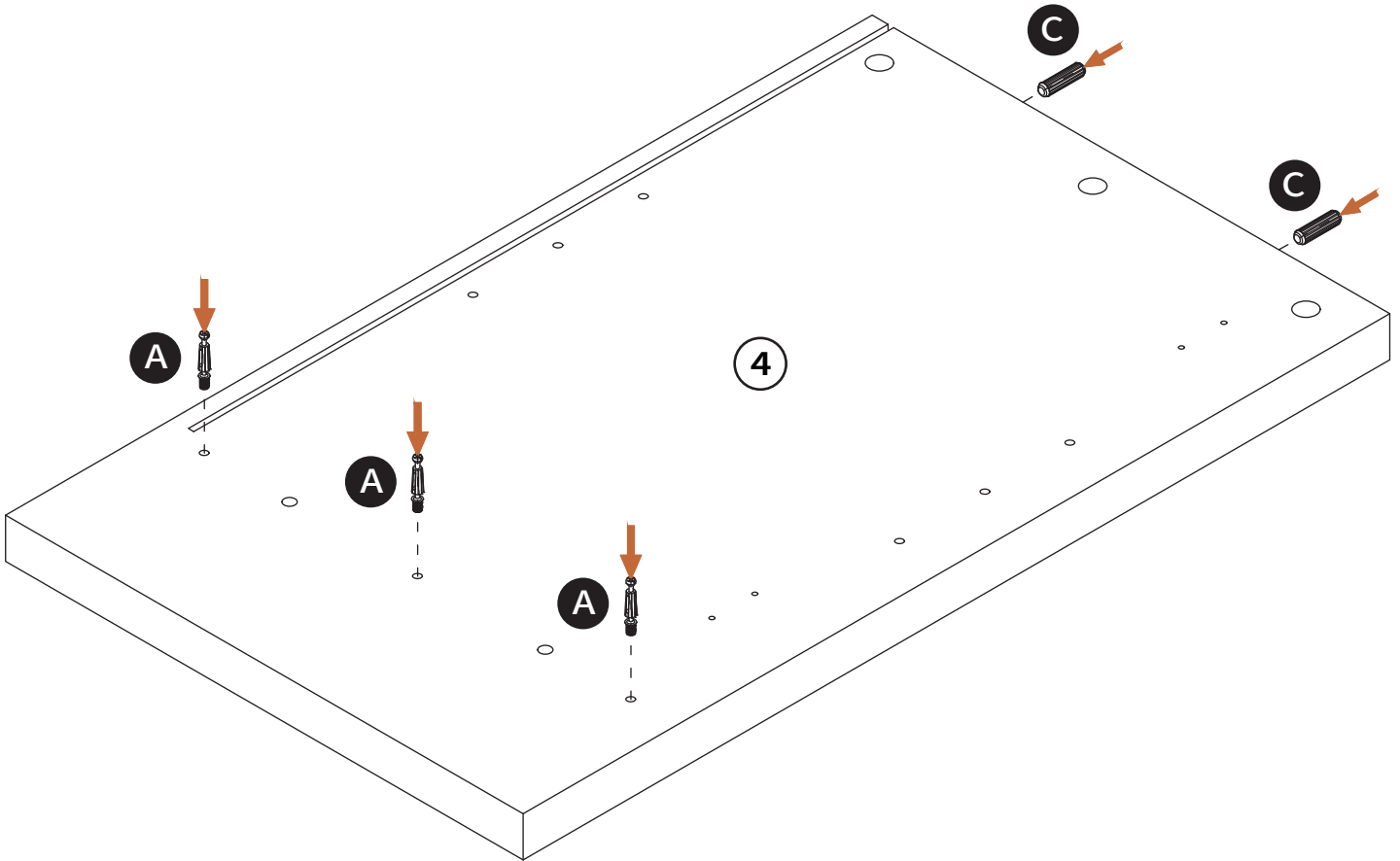

# 6

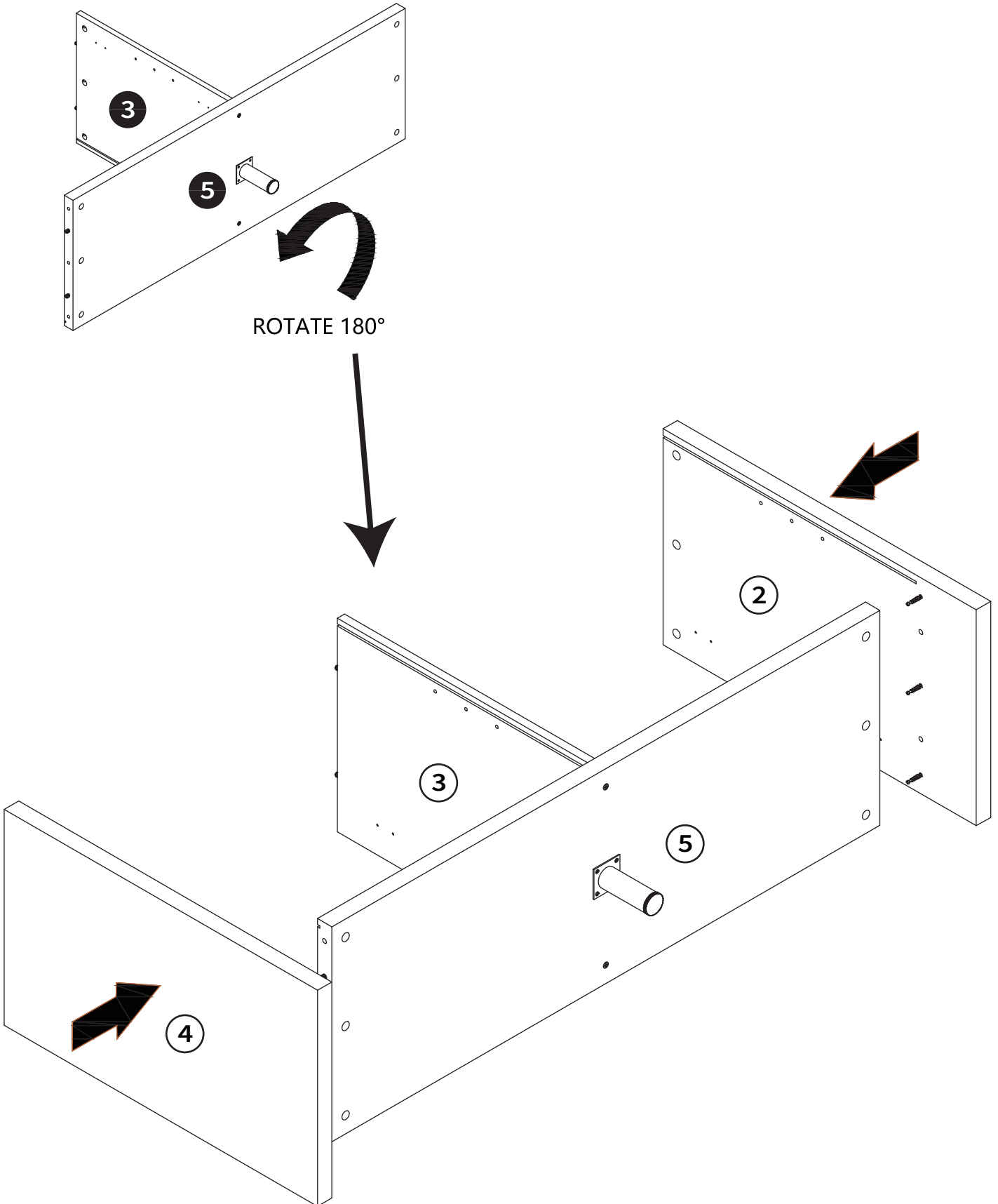

# 7

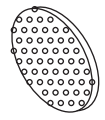
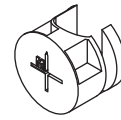

**B** X6

**H** X6

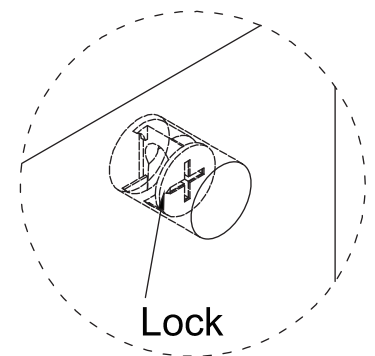
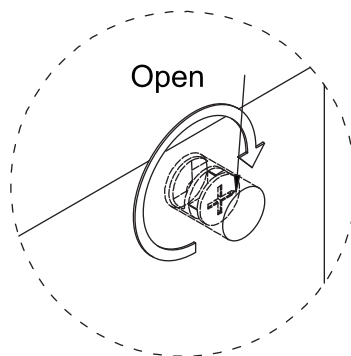
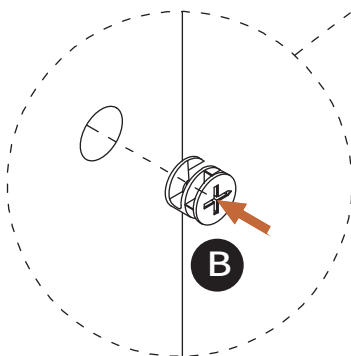
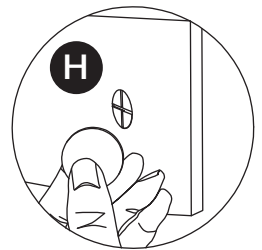
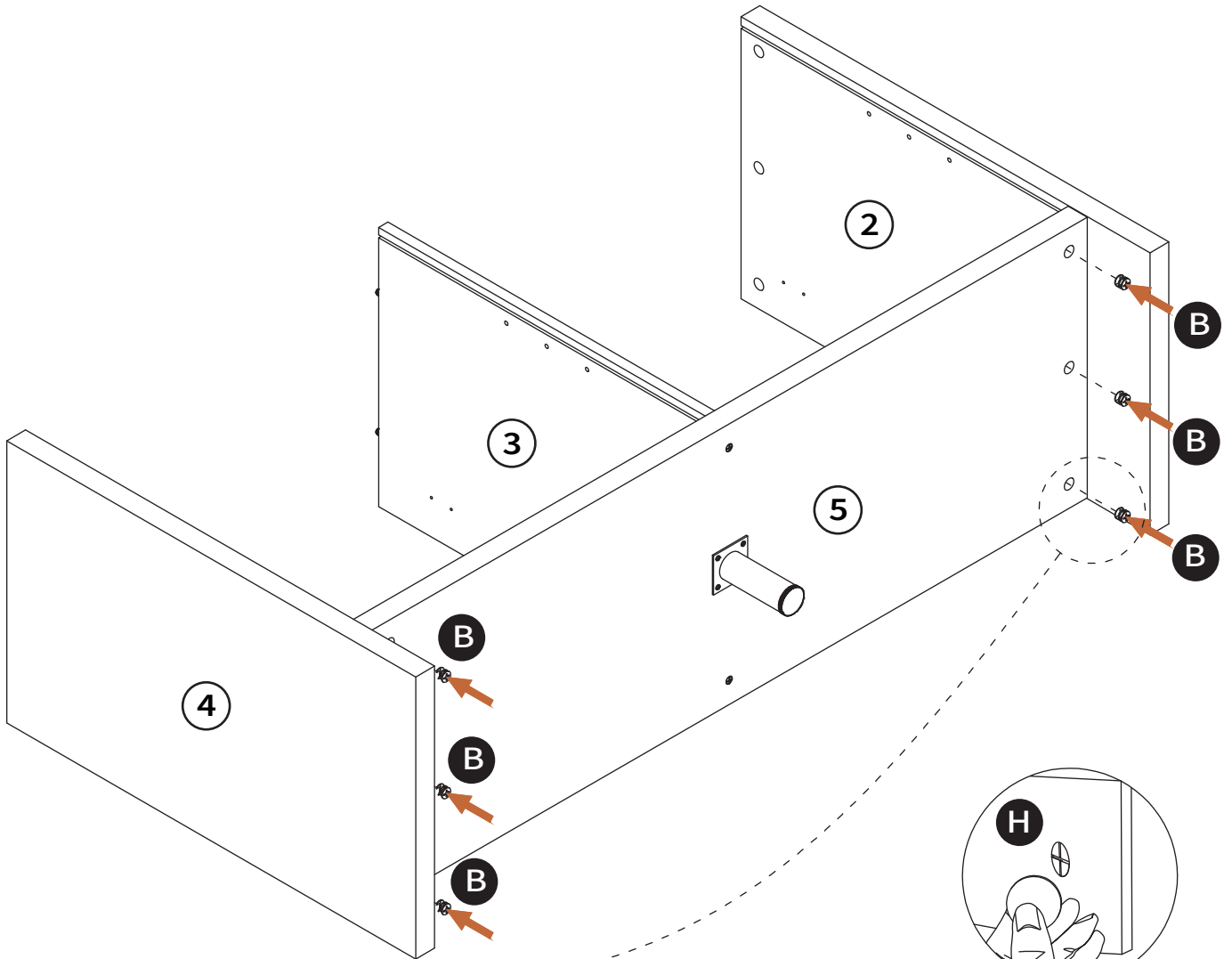

8

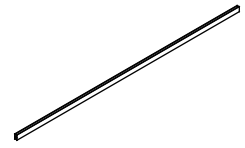

I X2

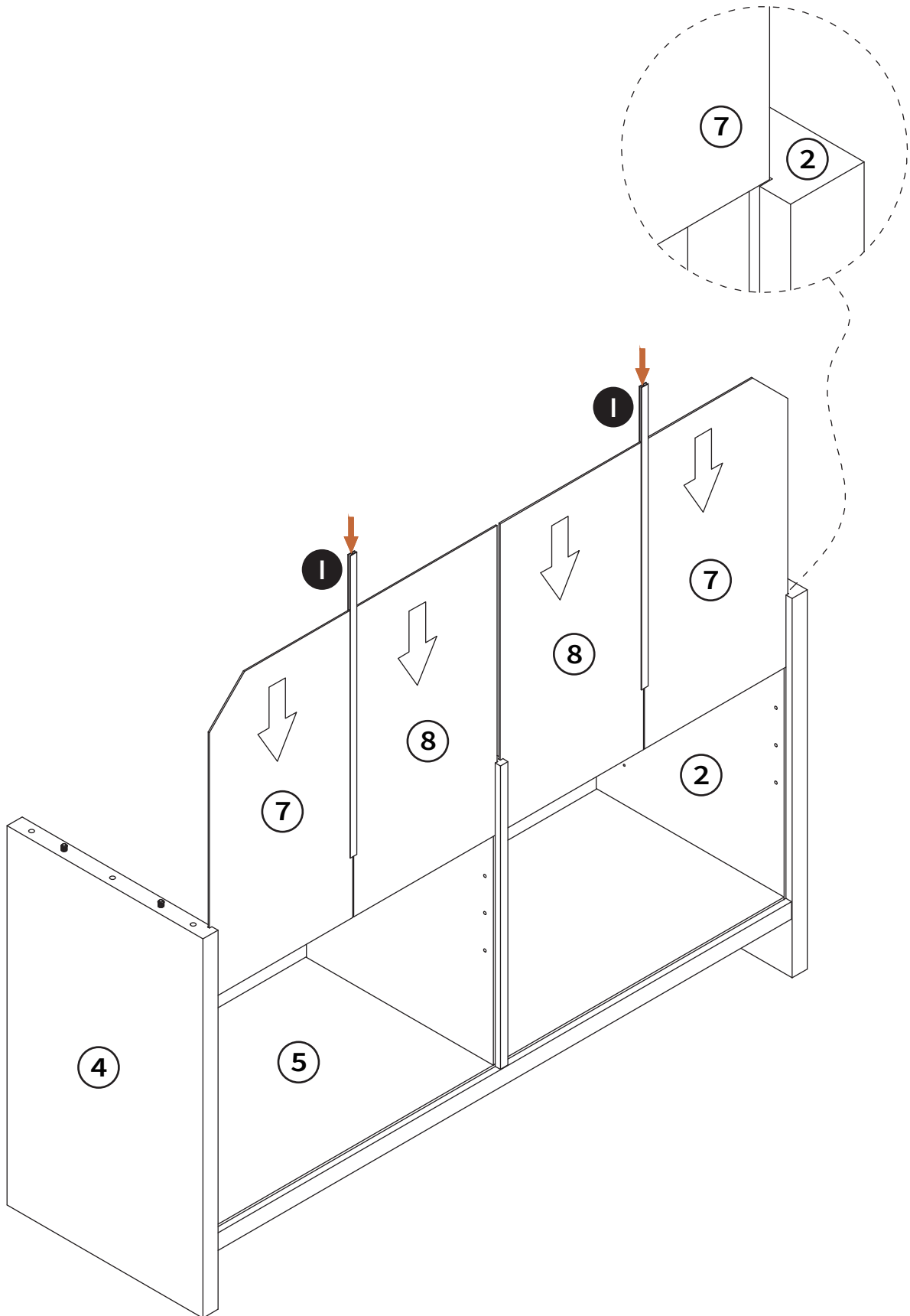

# 9

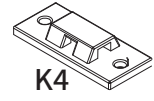
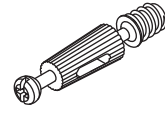

K4

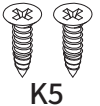

K5

**A** X9

**K** X2

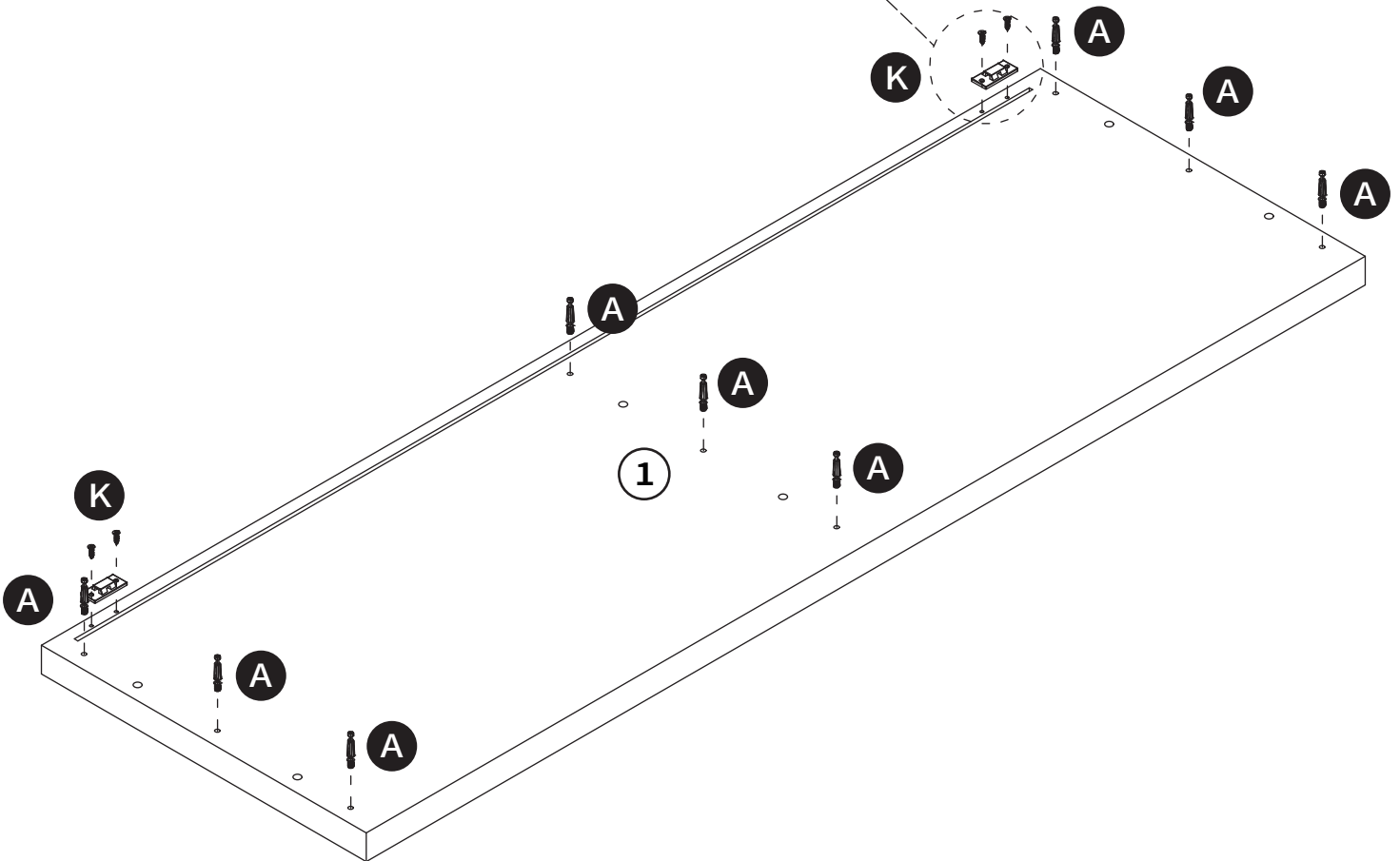
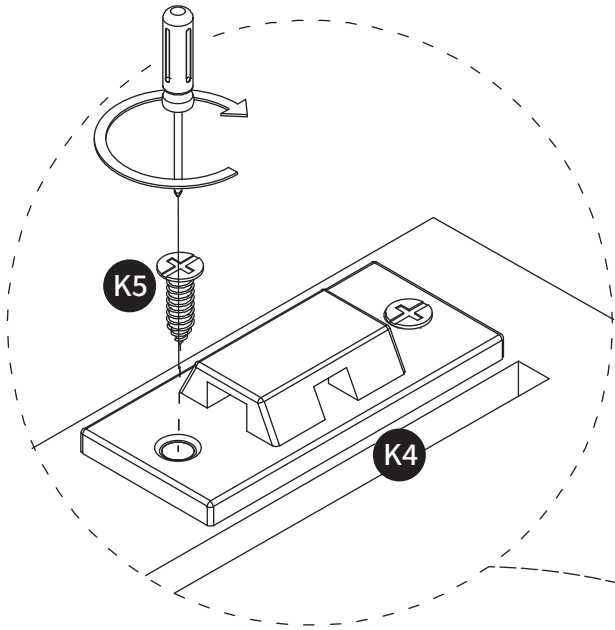

# 10

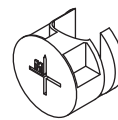

**B** X9

**H** X9

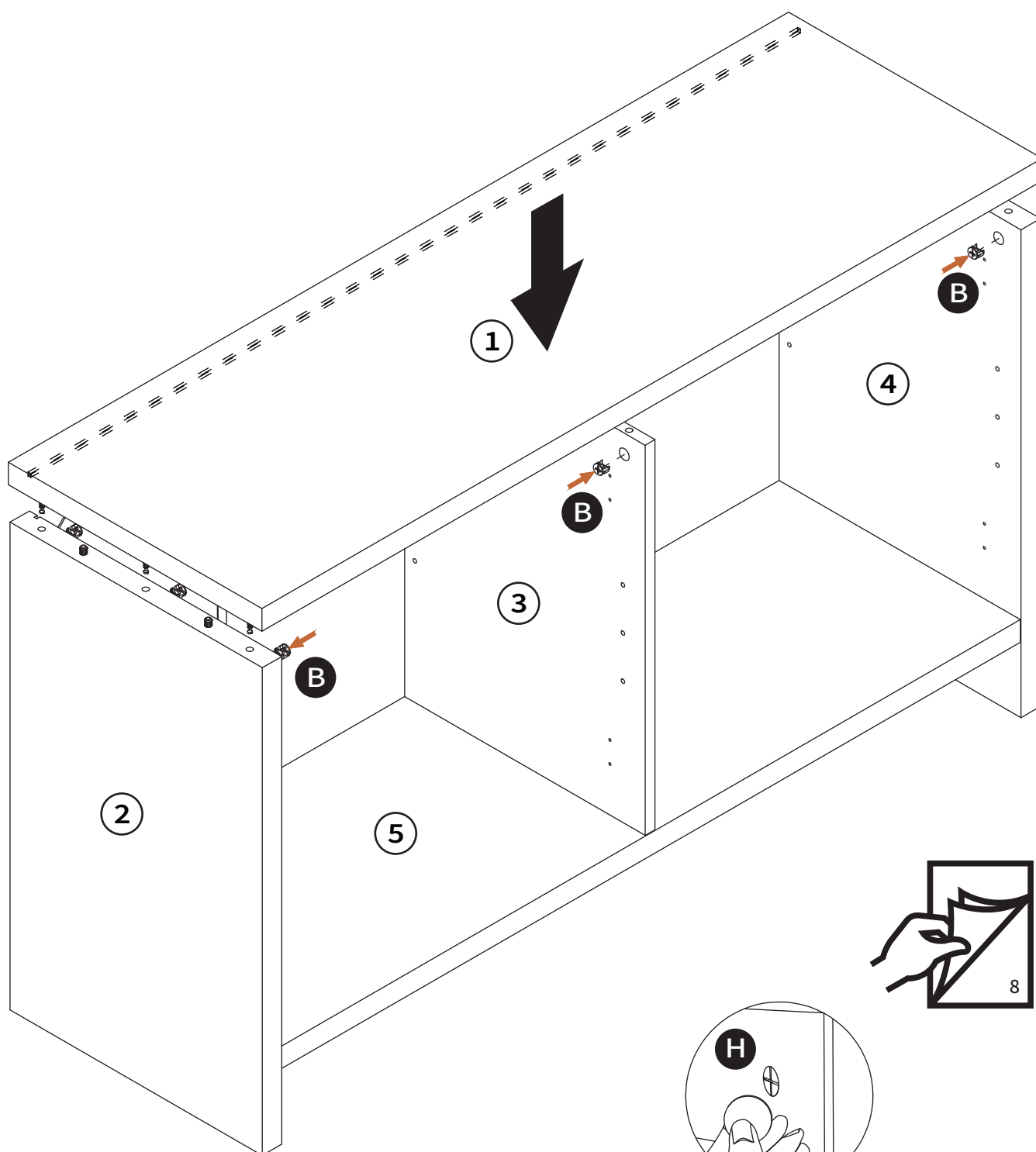

# 11

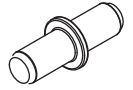

**G** X8

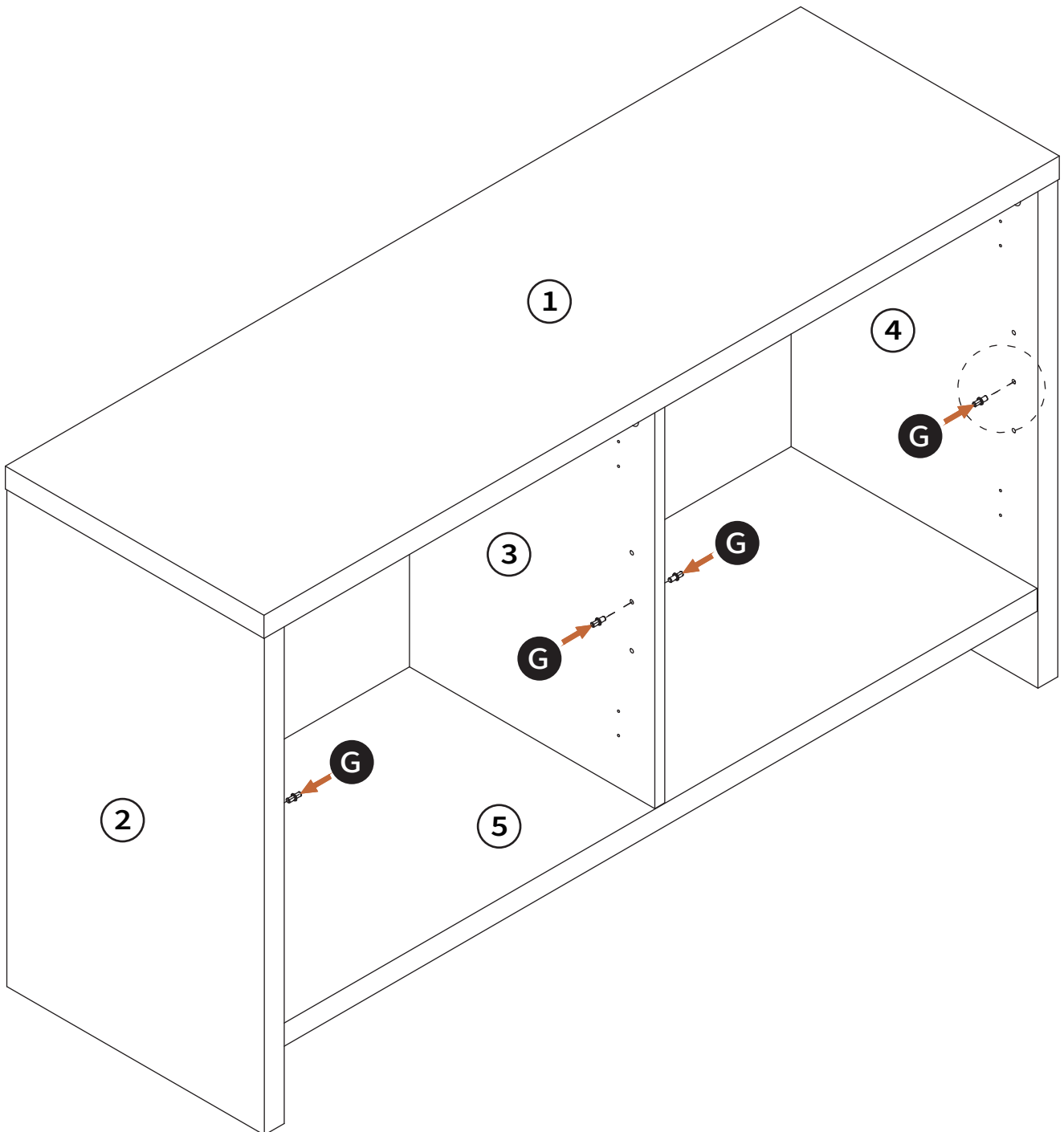
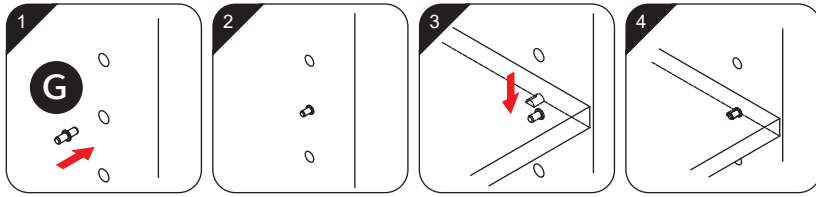

# 12

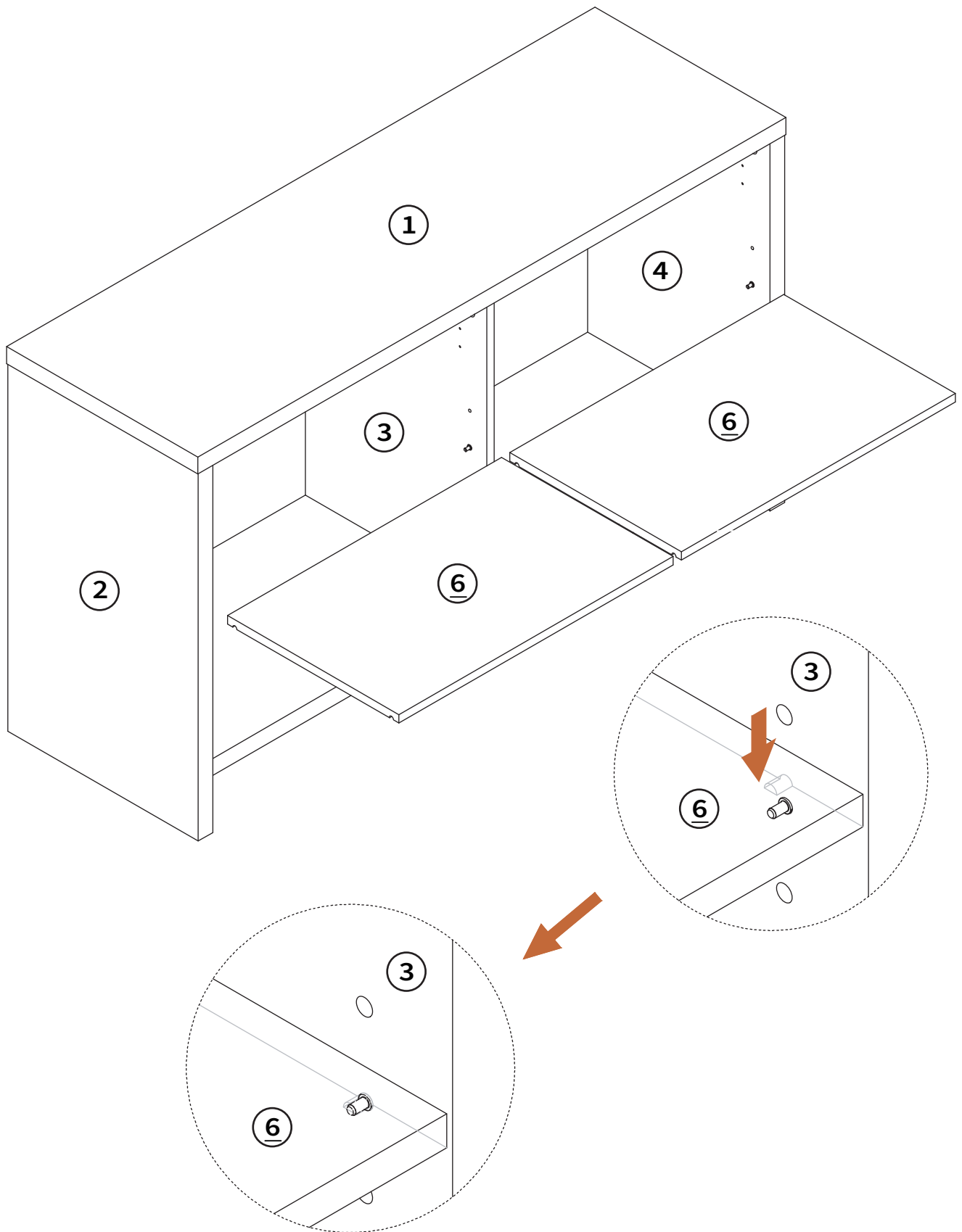

# 13

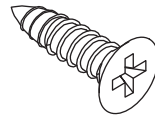

**F** X12

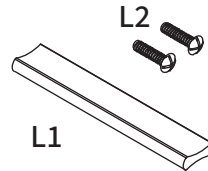

L1

L2

**L** X3

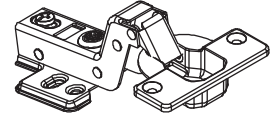

**J** X6

X3

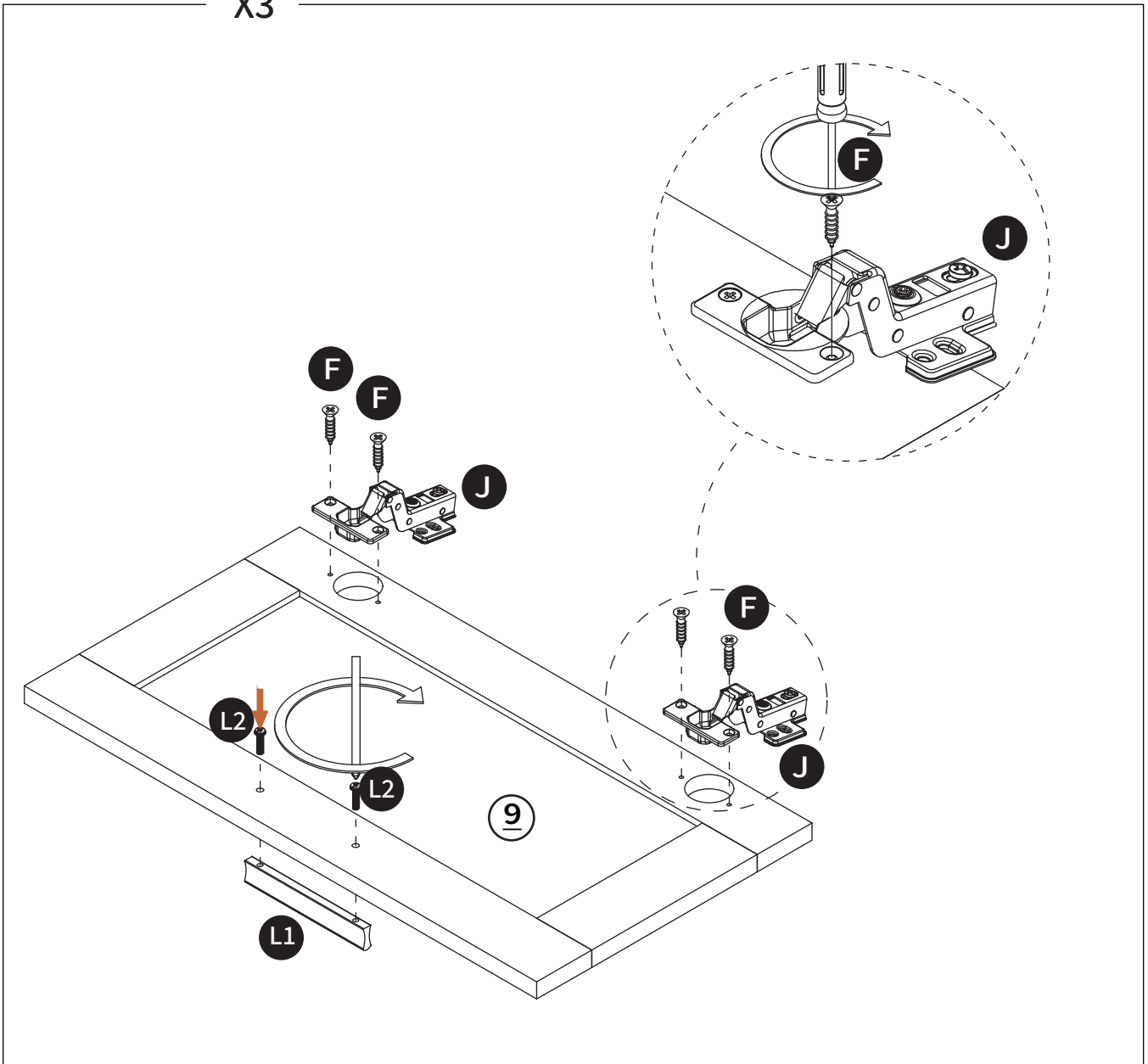

# 13

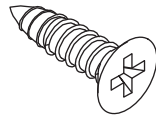

**F** X4

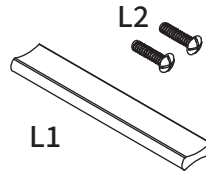

**L** X1

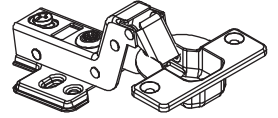

**J** X2

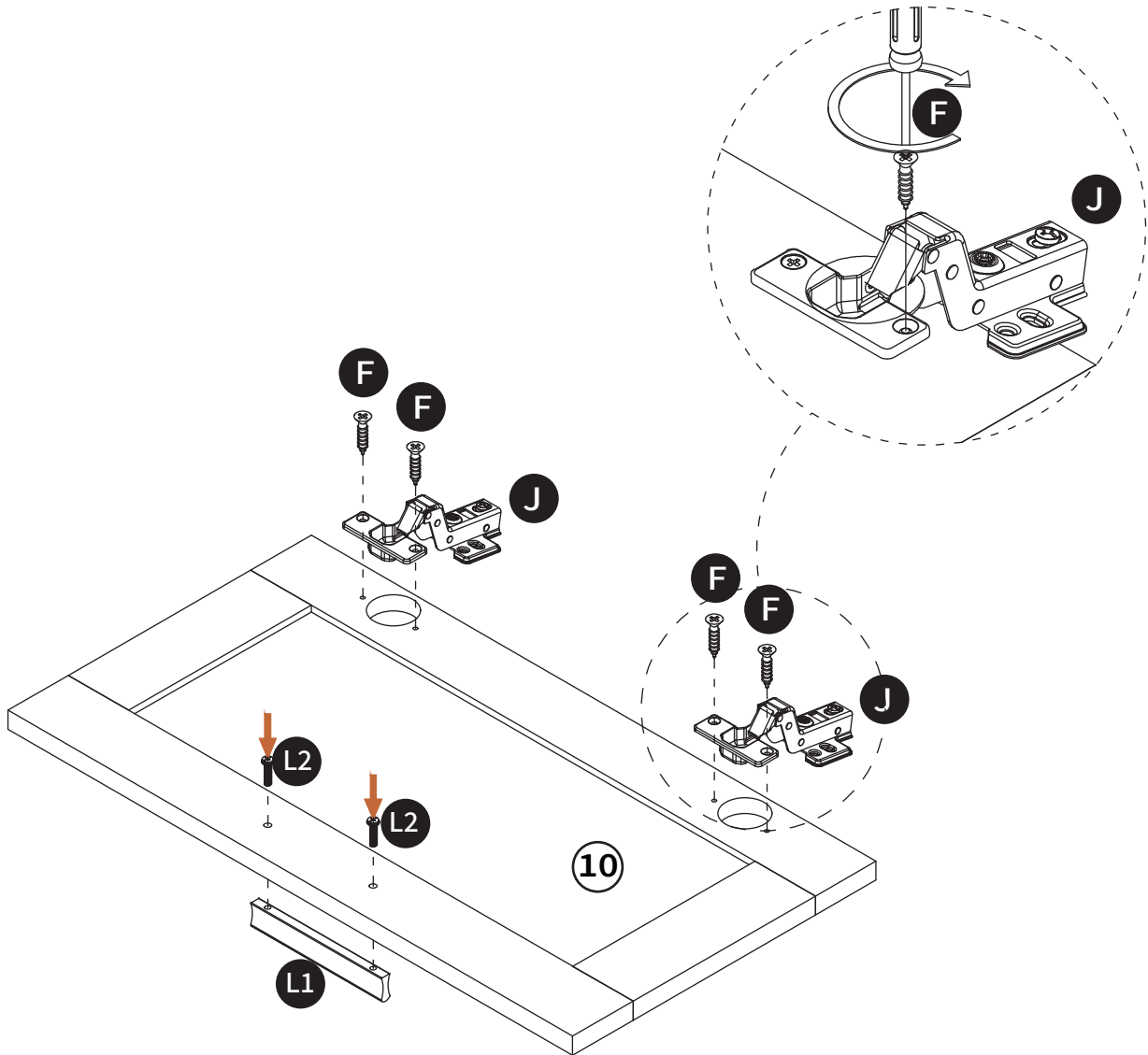

# 14

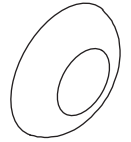
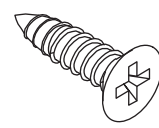

**F** X32

**N** X4

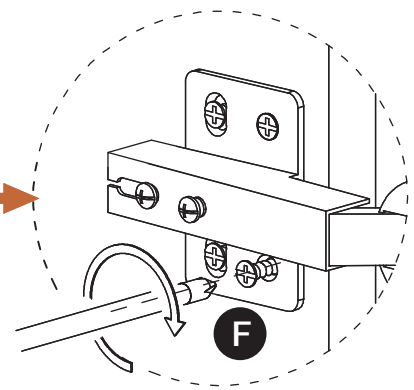
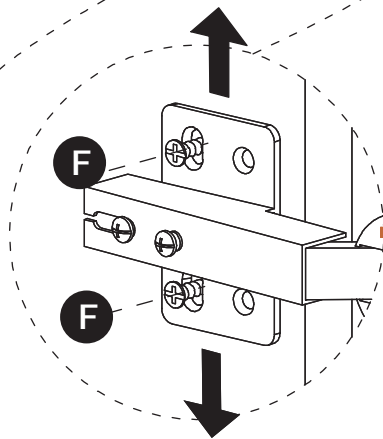
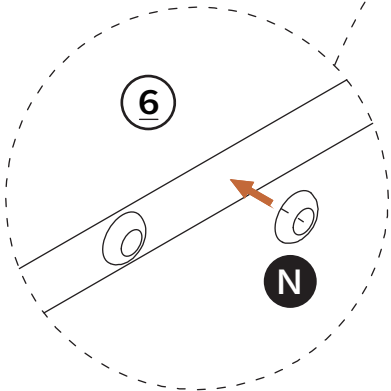
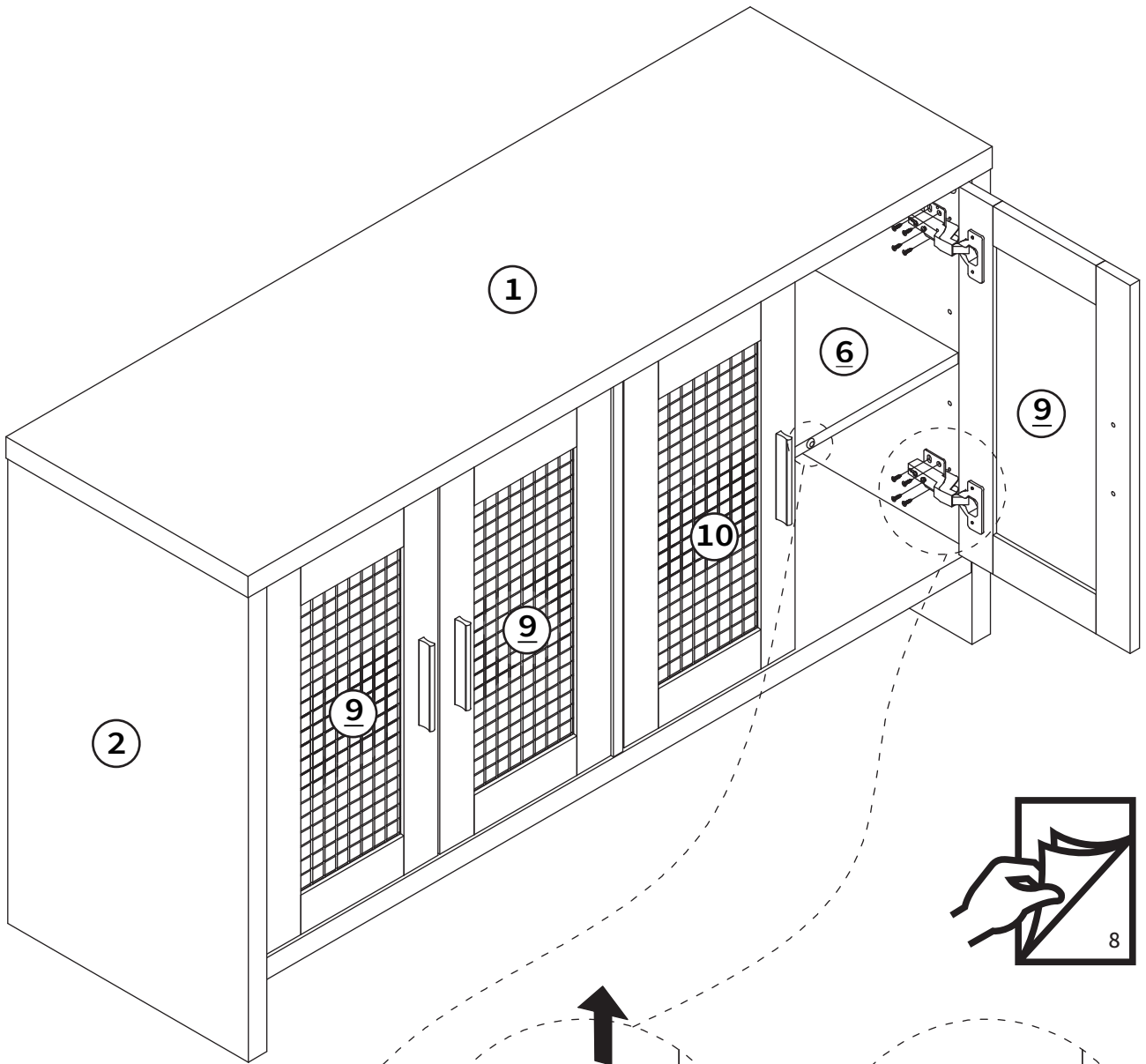

# 15

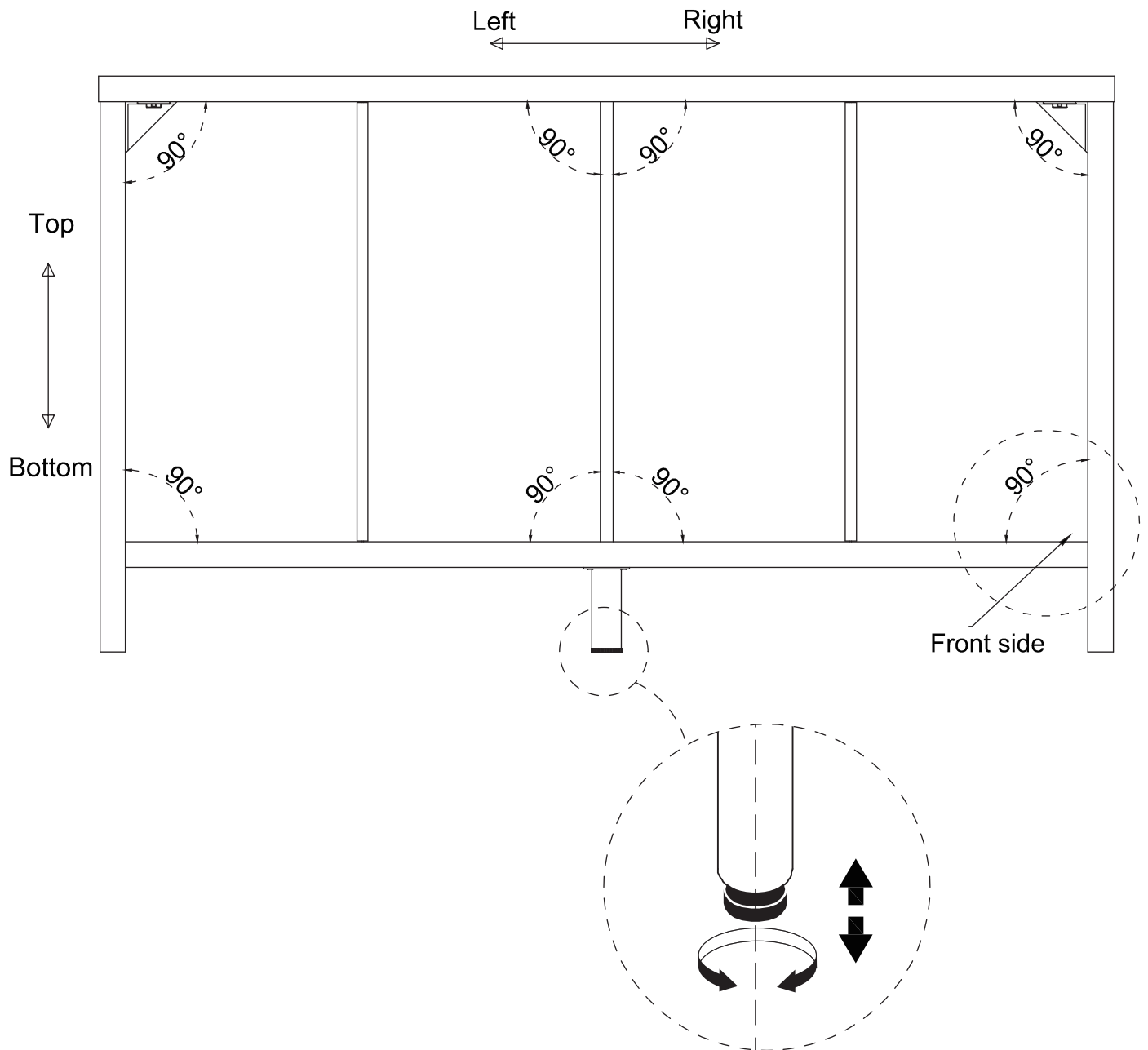

# 16

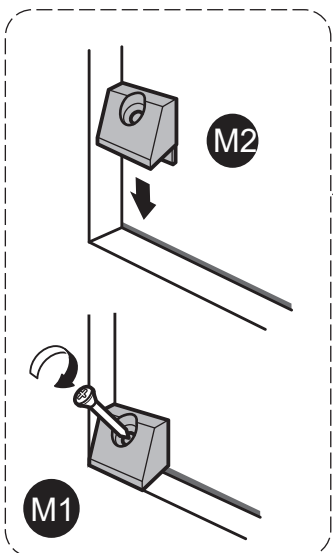
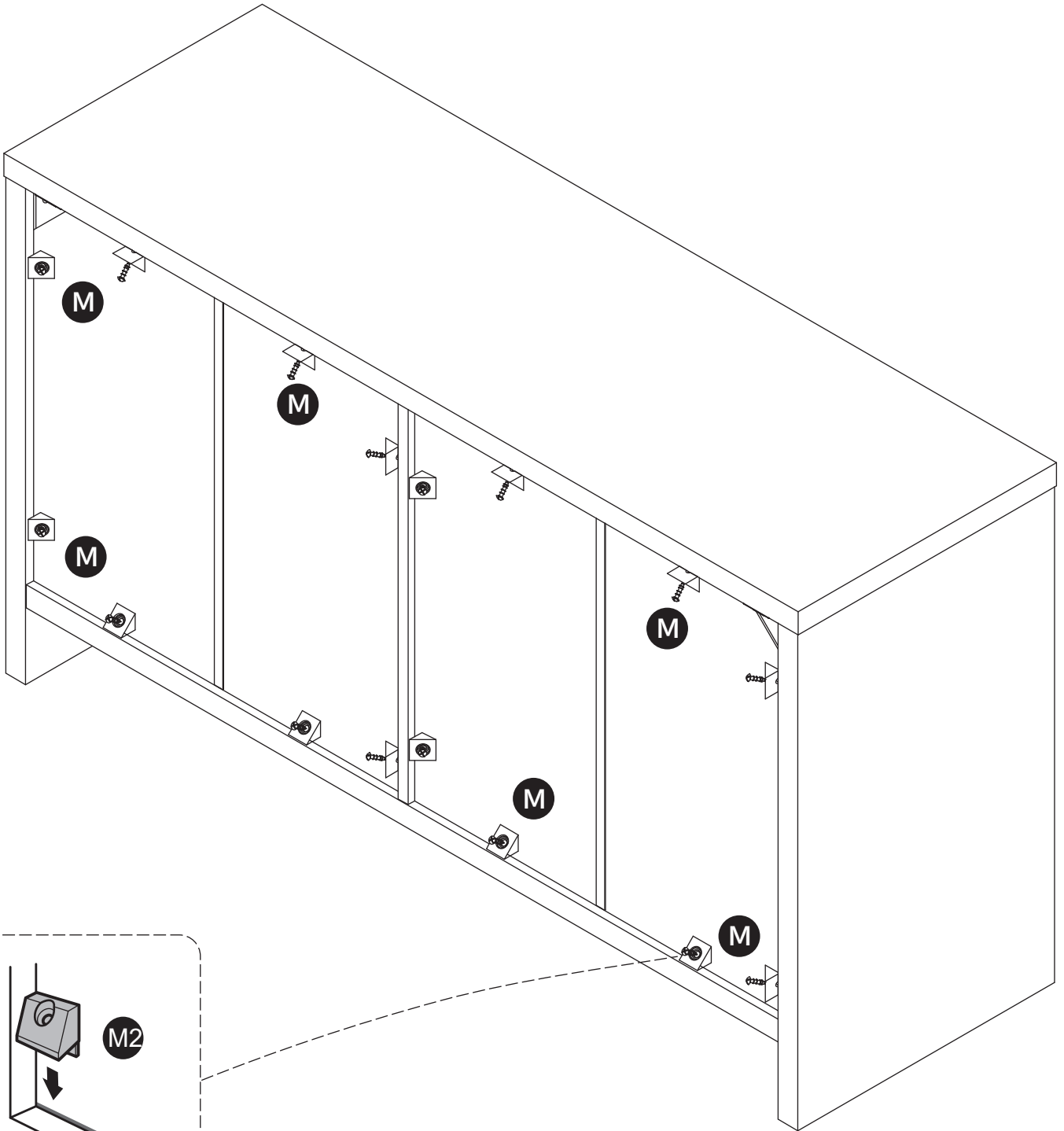
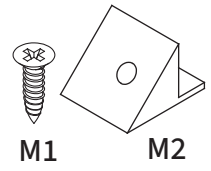

# 17

## Tips to adjust the position of door panel (door hinges)

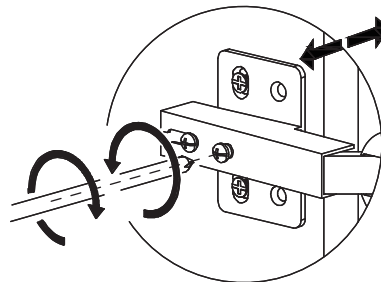
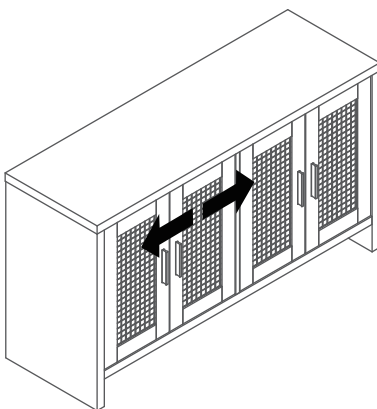
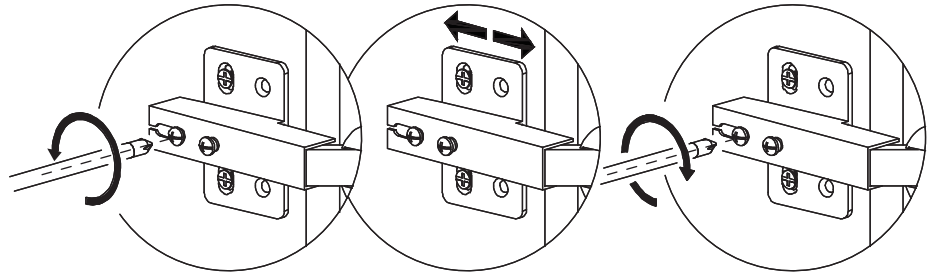
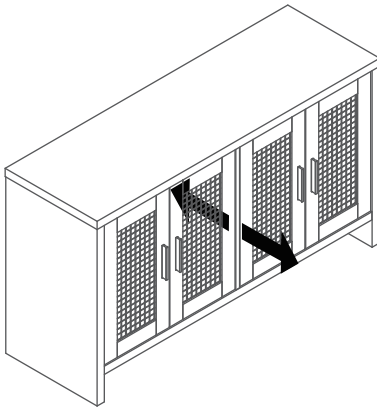
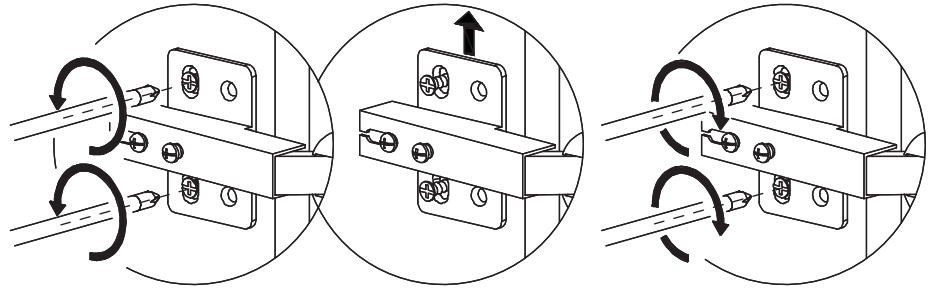
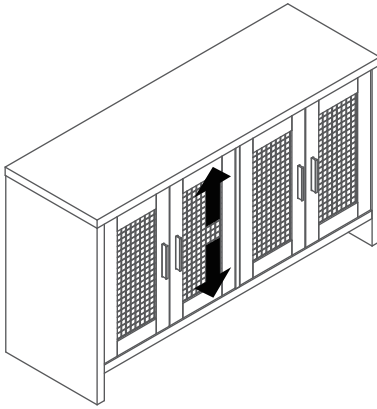

# 18

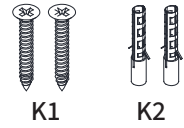

**K** X2

