

2 Drawer Nightstand

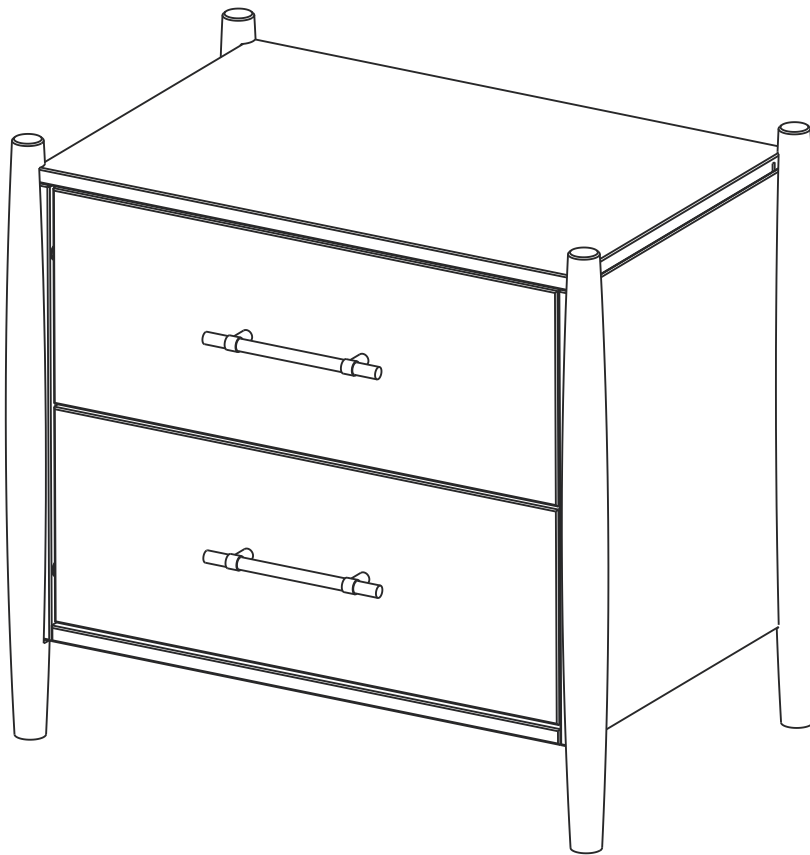

For Residential Use Only

Time to get started

Set up a clean and soft workplace to avoid damage during assembly. You can use the box and internal protections as a cover. It also helps to double-check if you have got all the pieces and parts before diving into the assembly.

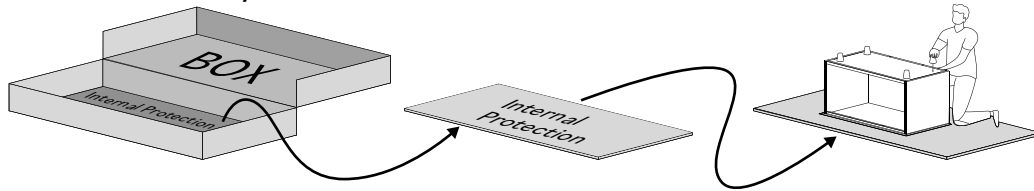

Estimated time
for assembly

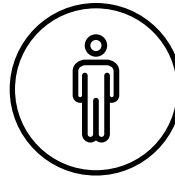

1Person
Build

**You can assemble
it alone.**

But you can make
it a team effort!
Grab a friend for quicker,
easier assembly.

Tools Needed

Grab a Phillips head screwdriver and a hammer to conquer this assembly.

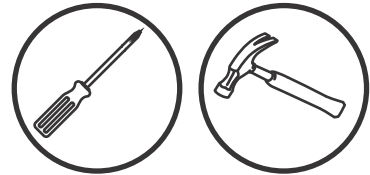

Use power tools with caution

This furniture is made of Solid Wood and Composite Wood, soft materials. If you choose to use power tools, set it to the slower setting. Be careful! Power tools can cause cracking or damage to the furniture, they can also damage the hardware if misused.

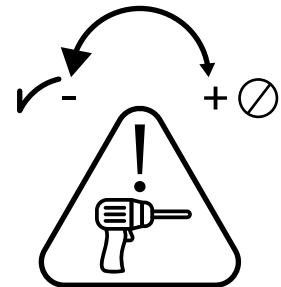





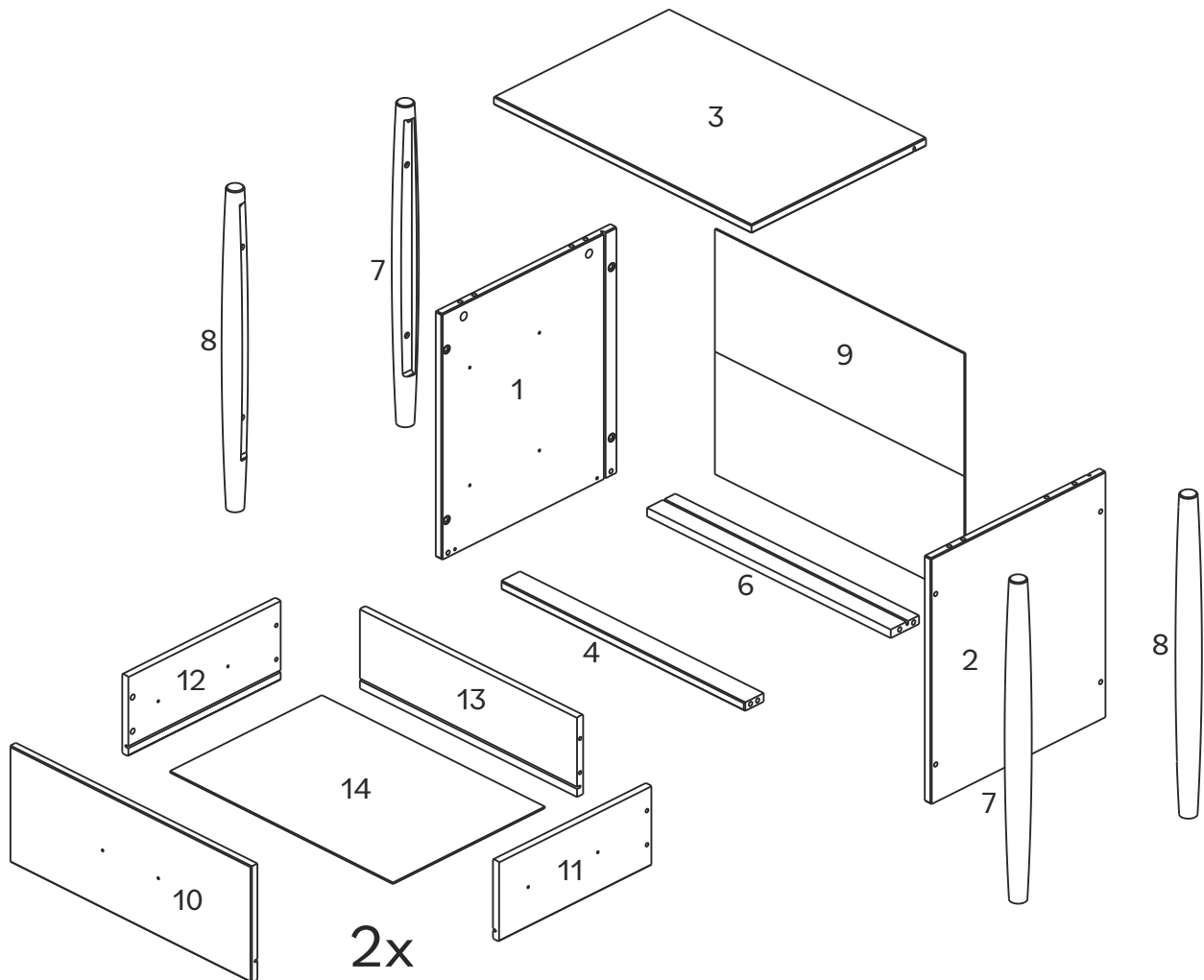







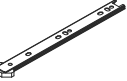

Parts List

Part Number	Description	Quantity
1	Left Panel	1
2	Right Panel	1
3	Top Panel	1
4	Front Rail	1
6	Back Rail	1
7	Right Foot	2
8	Left Foot	2
9	Back Panel	1
10	Drawer Front	2
11	Right Drawer Side	2
12	Left Drawer Side	2
13	Drawer Back	2
14	Drawer Bottom	2

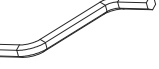

Hardware List

Part	Size	Name	Quantity
A		Dovetail	4
B		Dovetail Lock	8
C		Plastic Screw	8
D	 6x12mm	Screw	8
E	 6x14mm	Screw	8
F1	 250mm	Outer Slider	4
F2	 250mm	Inner Slider	4
G		Handle	2
H	 3,5x30mm	Screw	4
I	 8x30mm	Wooden dowel	8
J	 6x31mm	Cam bolt	8
K	 15x11mm	Cam Lock	8
L	 7x35mm	Bolt	8
M		Hex Key	1
N		Wedge	10
O	 3,5X14mm	Screw	10

*The hardware quantities listed above are required for proper assembly.
Extra hardware pieces may be included.*

Introducing The Easy Assembly Drawer System

Say Goodbye to Assembly Hassle!

We understand that assembling drawers can be the most time-consuming and tedious part of putting together your new furniture. That's why we've developed the Easy Assembly Drawer System - to make the process easy!

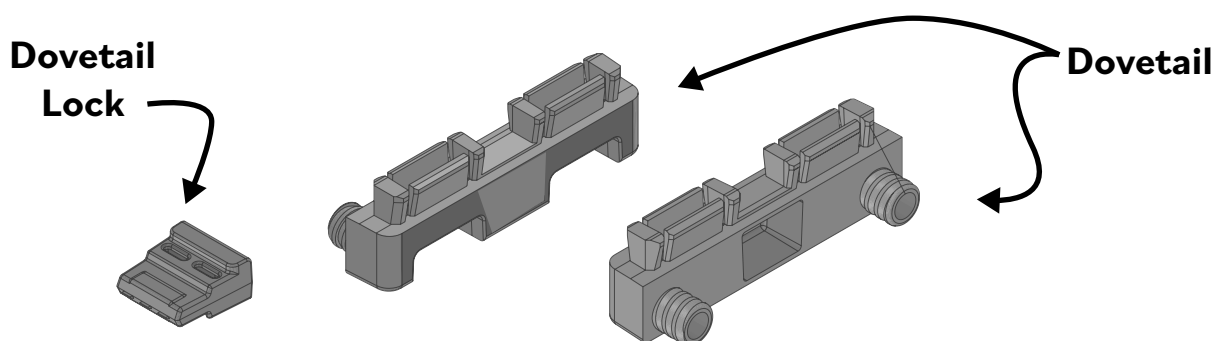

Why You'll Love Our Easy Assembly Drawer System:

Quick & Easy: Our new drawer hardware significantly reduces your assembly time. Get it done in no time!

Minimal Effort Required: Designed to be super simple, you'll need little to no tools to get the job done.

Built to Last: Strong and sturdy, our system ensures that your drawers stay solid and reliable.

Let's set the stage to assembly:

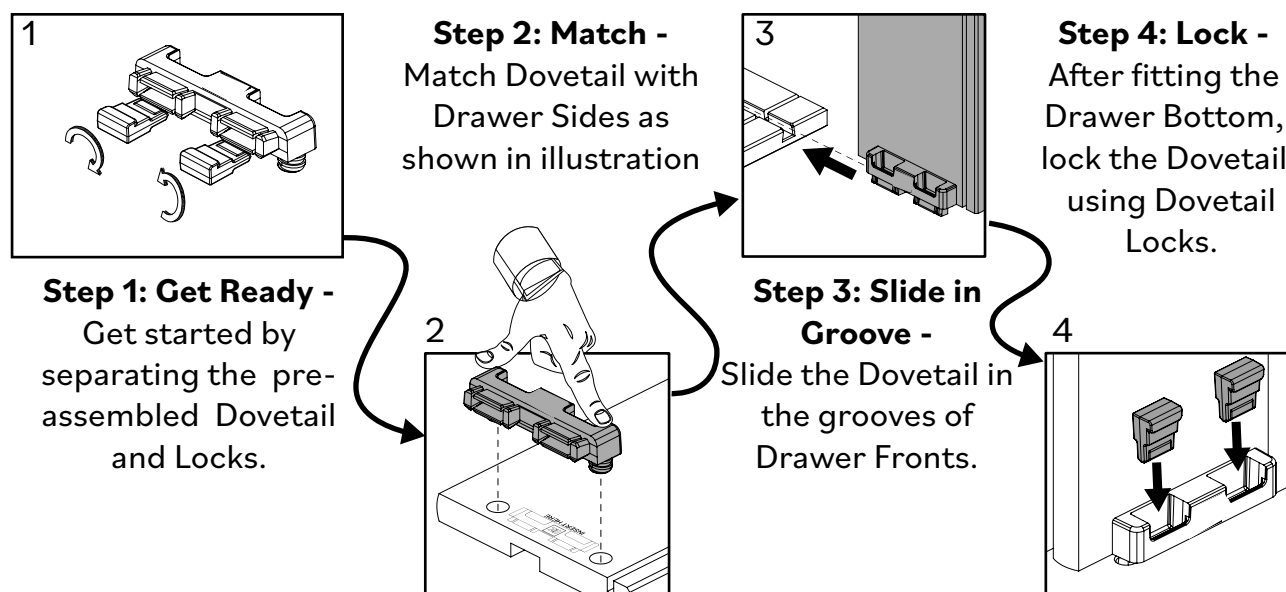

Attention: In the next steps there are more details to help you assemble.

Step 1

Prepare the Dovetails (A) by removing the Dovetail Locks (B) from the Dovetails (A).

1st

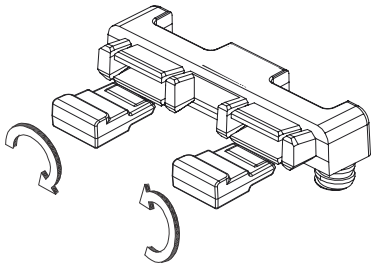

2nd

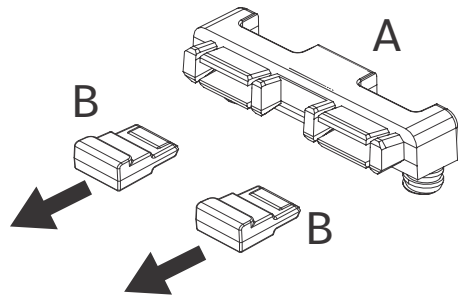

Step 2

Snap the Dovetails (A) into place on Right Drawer Side (11) and Left Drawer Side (12). Press the Dovetails until they are completely attached. Use a hammer if necessary.

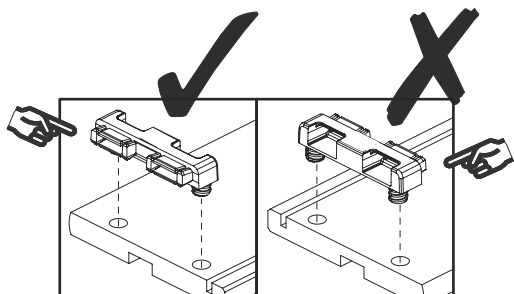

Press the piece until it is completely attached

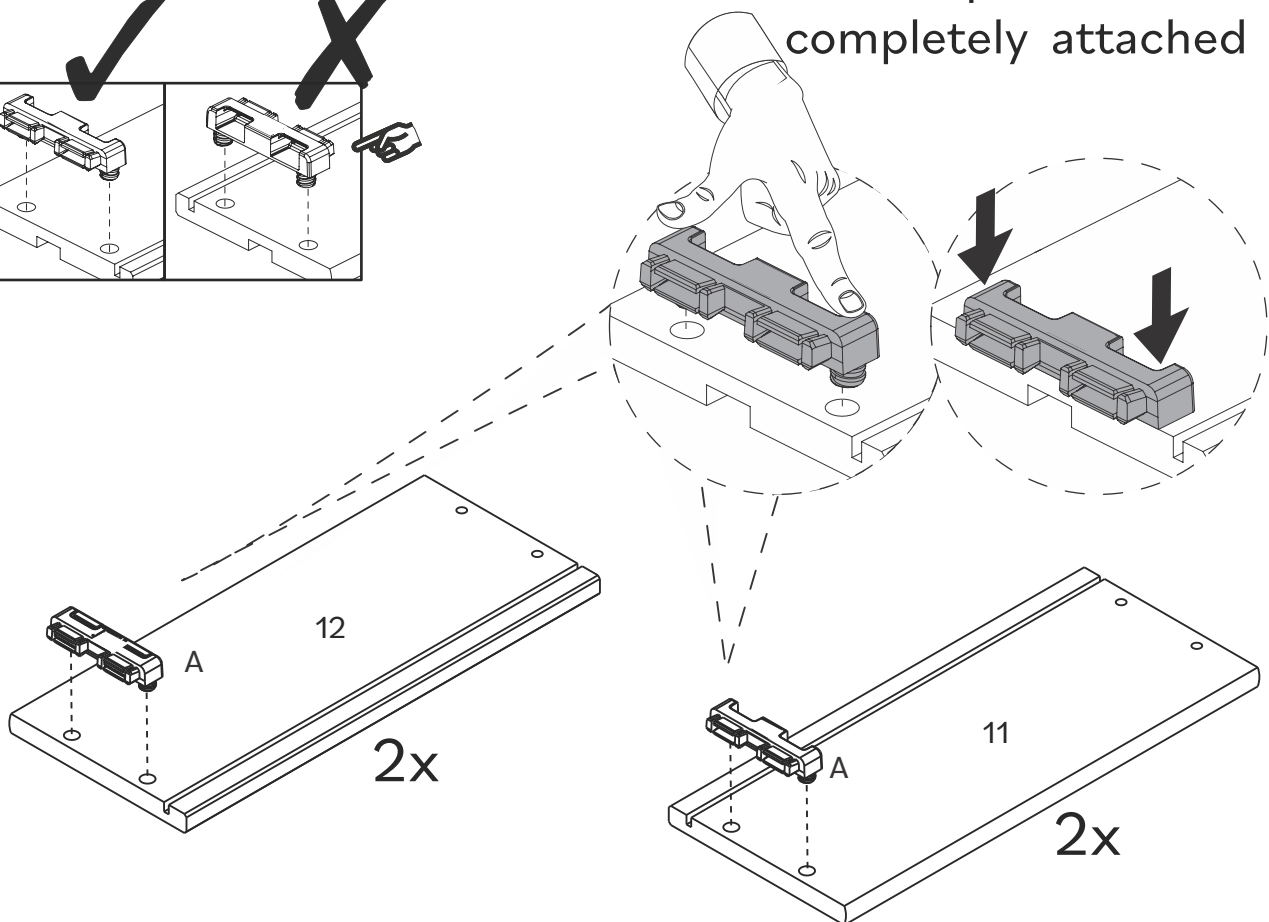

Step 3

Slide the Dovetail (A) on the Right Drawer Panel (11) and Left Drawer Panel (12) into the grooves on the Drawer Front (10).

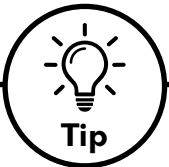
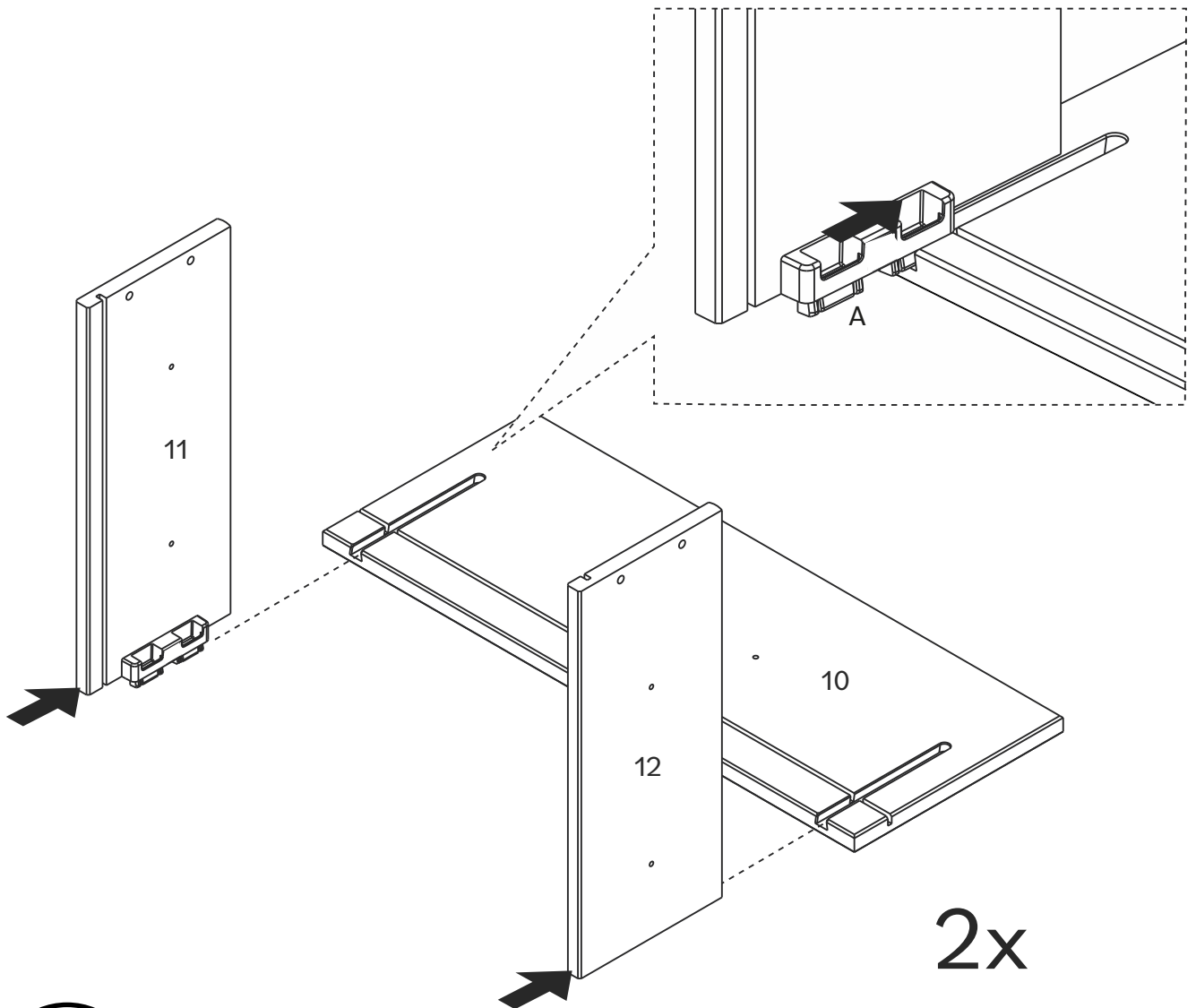

To keep your product looking its best and scratch-free, try assembling it on a soft surface like carpet or a blanket. This helps prevent any accidental scratches and keeps your furniture in top shape!

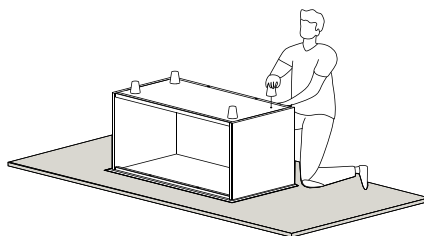

Step 4



Slide Drawer Bottom (14) between the grooves on Right Drawer Side (11) and Left Drawer Side (12) fitting in Drawer Front (10).

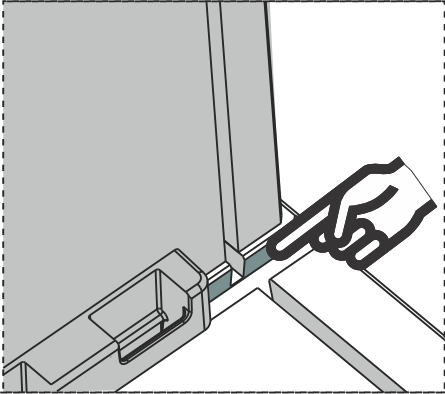

Align the grooves on the Drawer Sides and Drawer Front to receive the Drawer Bottom

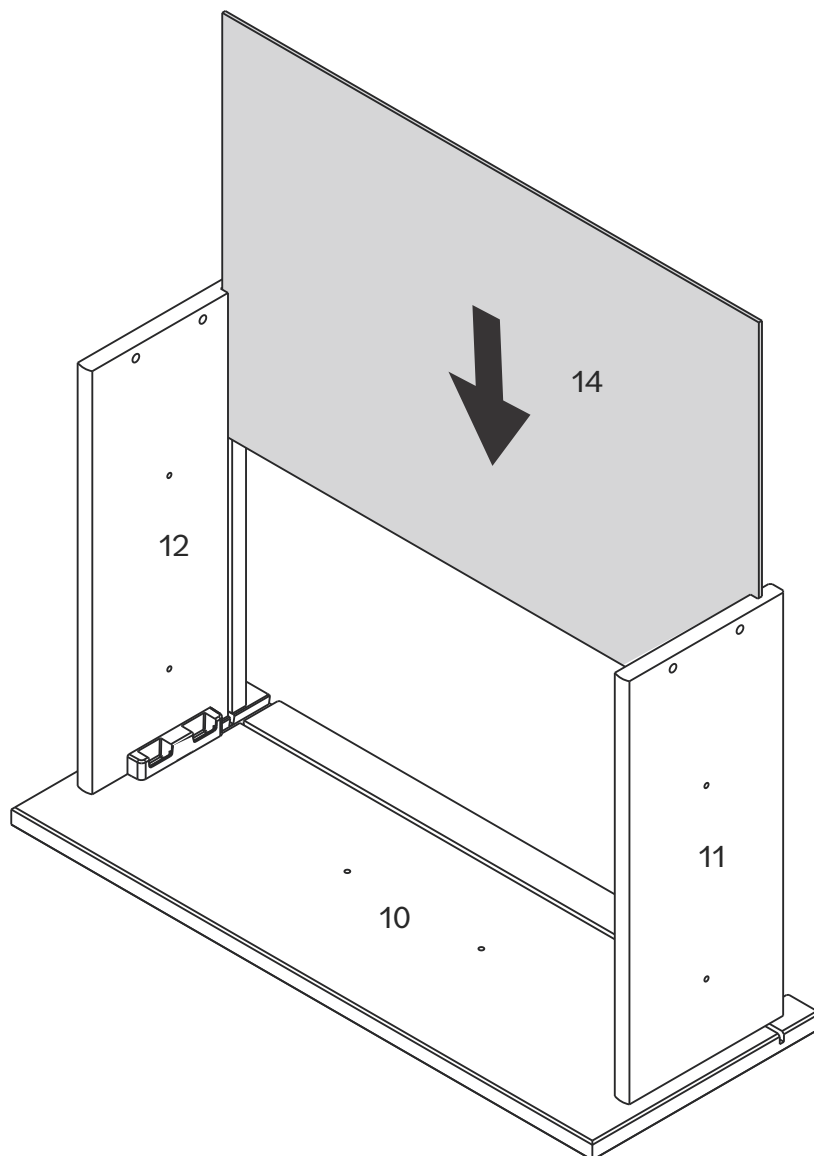

Step 5



To secure the Drawer sides, insert the Dovetail Locks (B) into the Dovetails (A). Use a hammer if necessary.

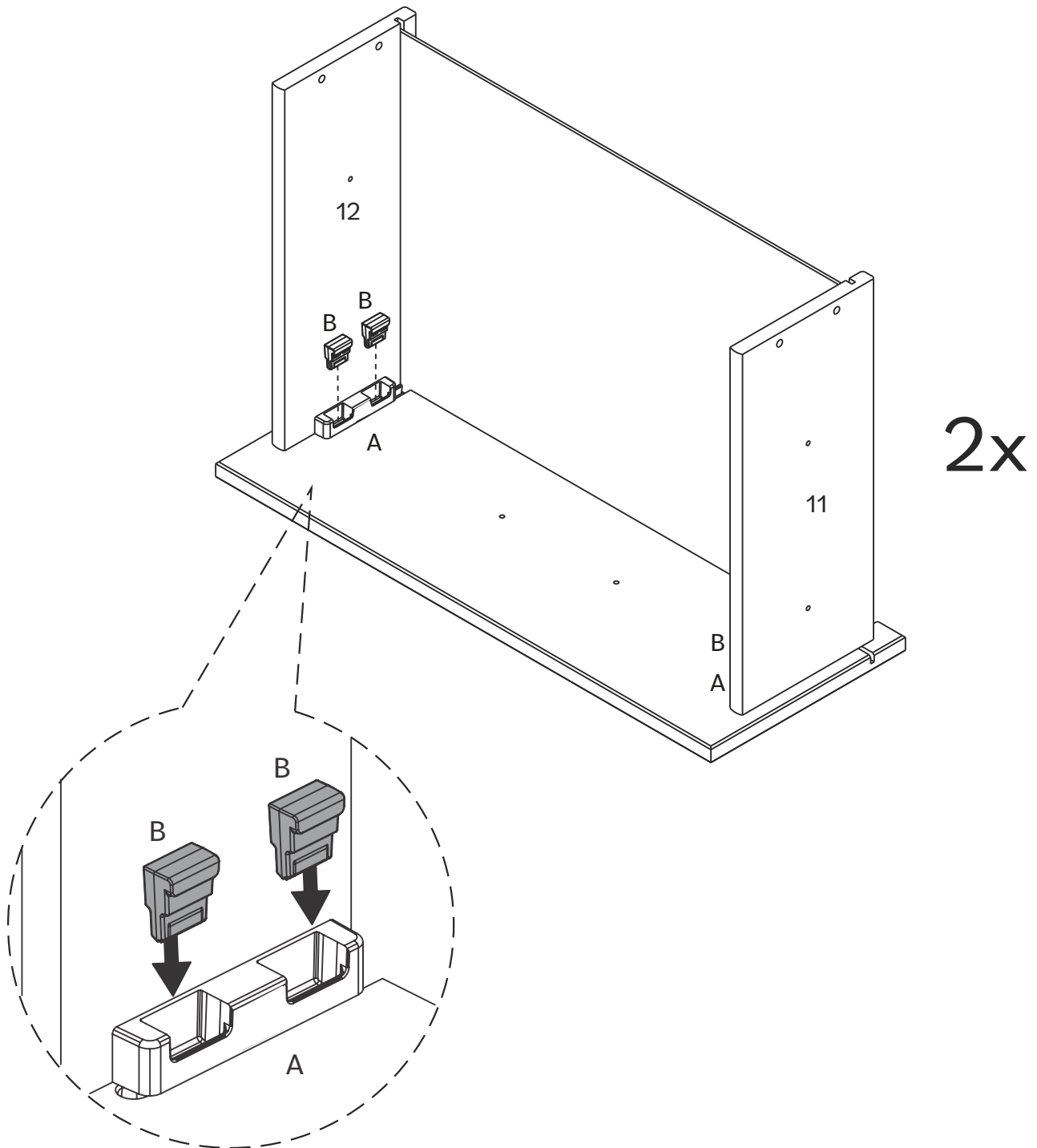

Step 6



Fit Drawer Bottom (14) to Drawer Back (13) and secure using Plastic Screw (C), you can insert it with your hands or using a hammer.

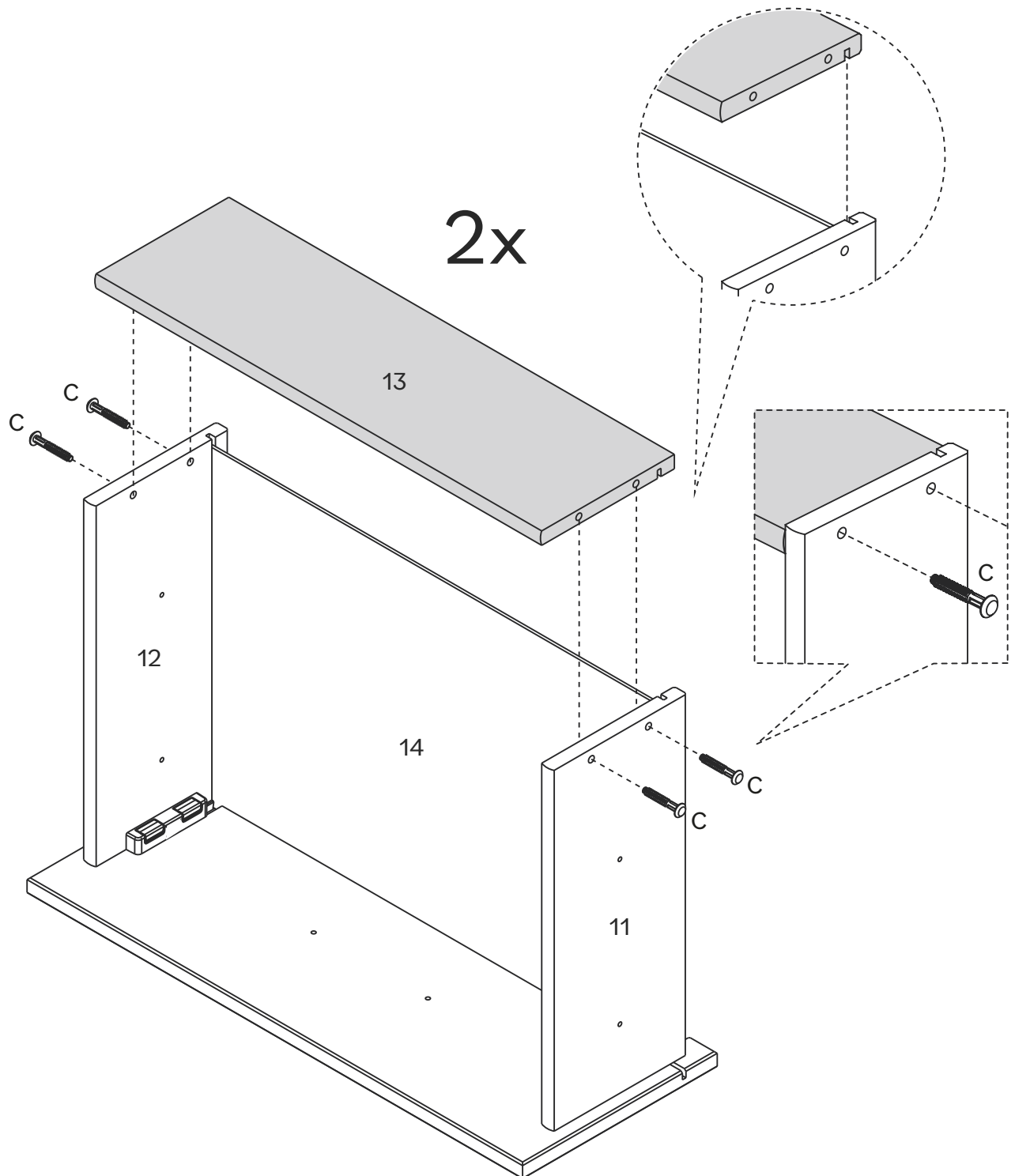

Step 7



Attach Inner Sliders (F2) to Right Drawer Sides (11) and Left Drawer Sides (12) using Screw (D) and a Phillips screwdriver.

Separate parts F1 and F2 by pressing the lock.

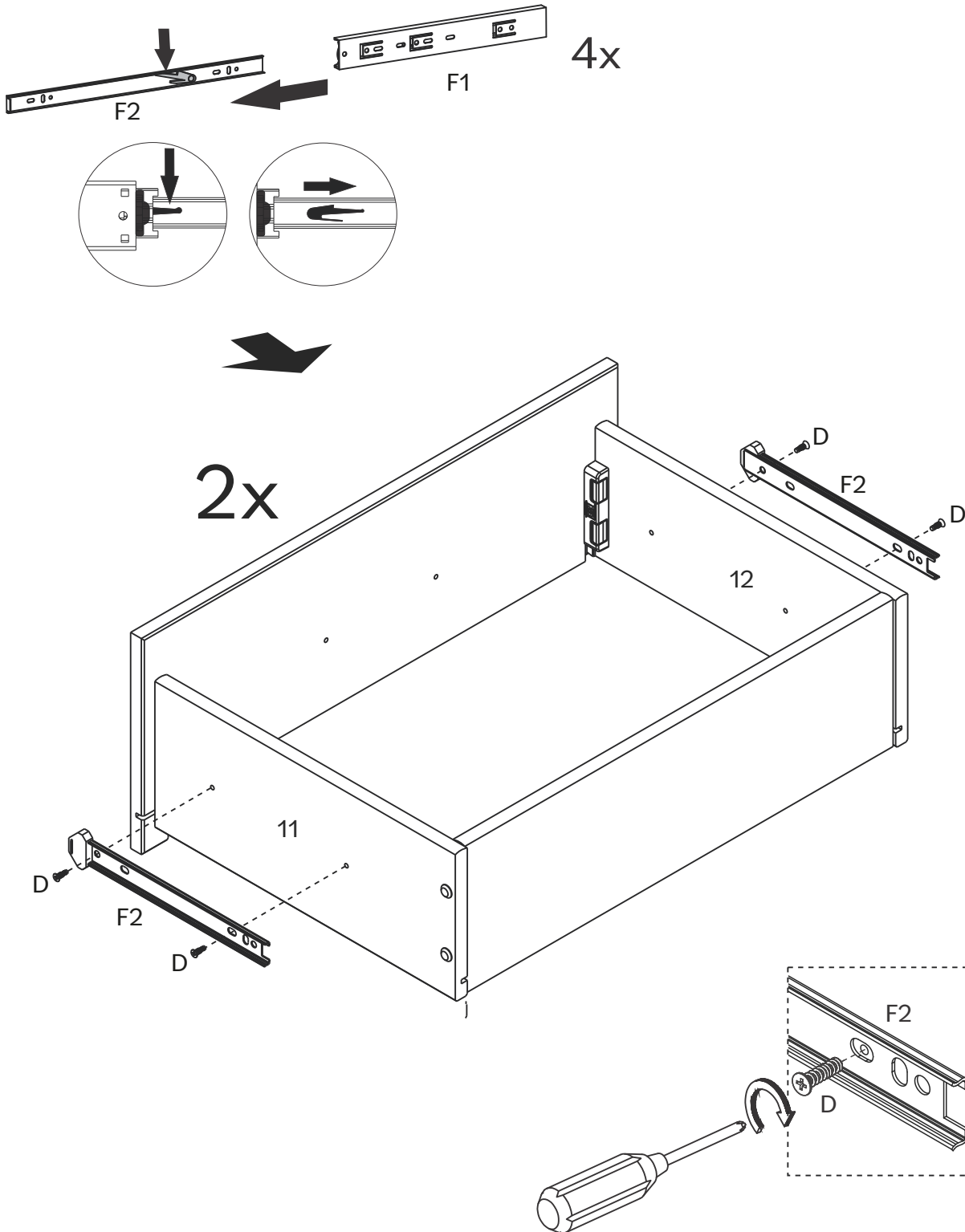

Step 8



Use Screws (H) and a Phillips screwdriver to secure Handles (G) to Drawer Fronts (10).

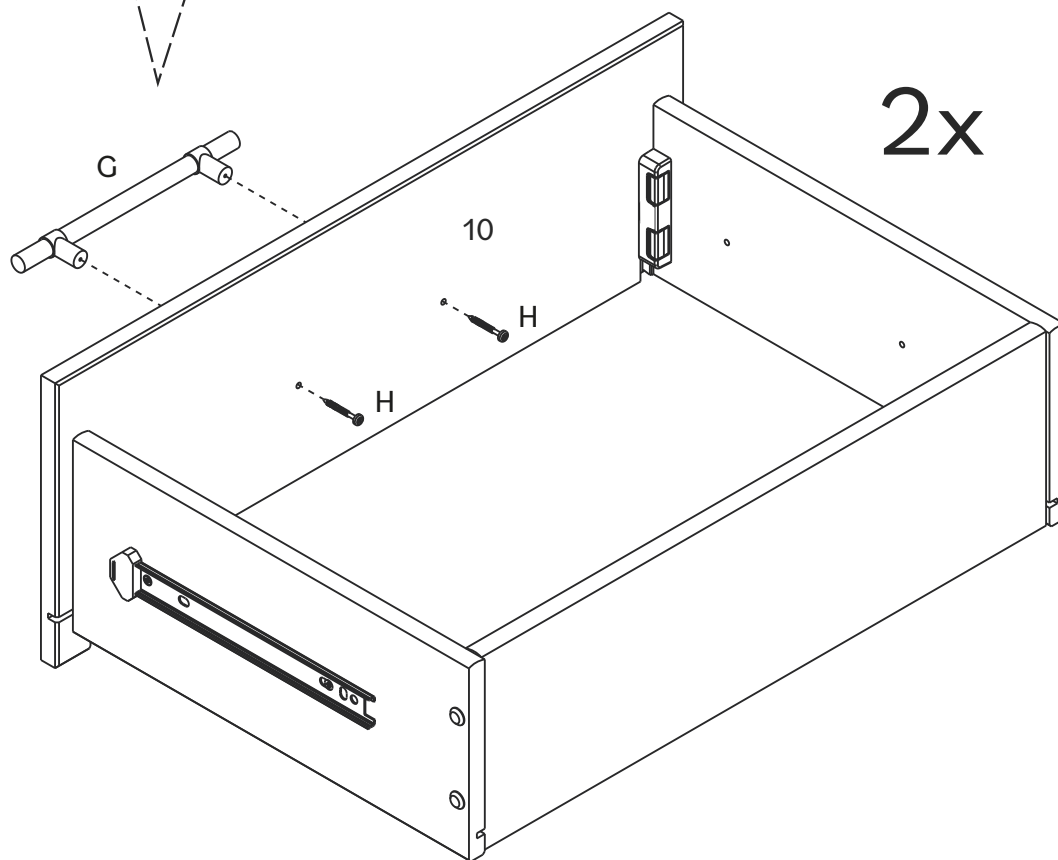
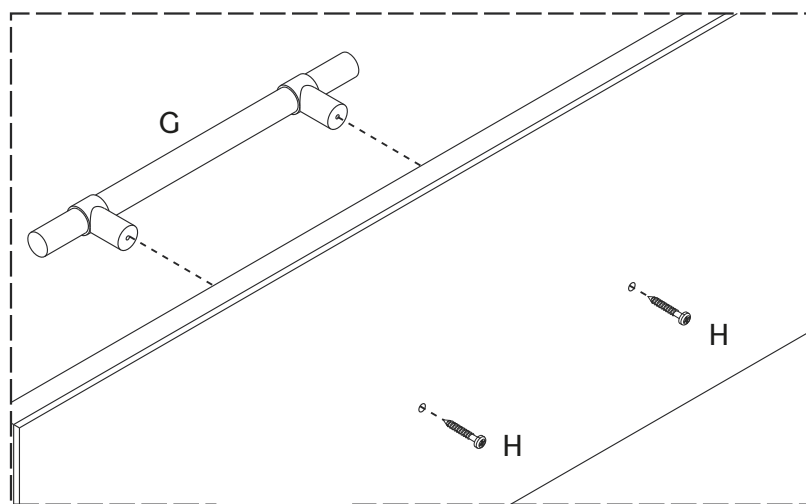

Step 9

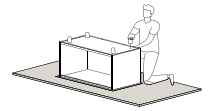

Now that the drawer is assembled, let's work on the nightstand. Insert Wooden Dowels (I) into Left Panel (1), Right Panel (2), Front Rail (4) and Back Rail (6).

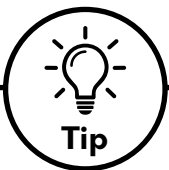
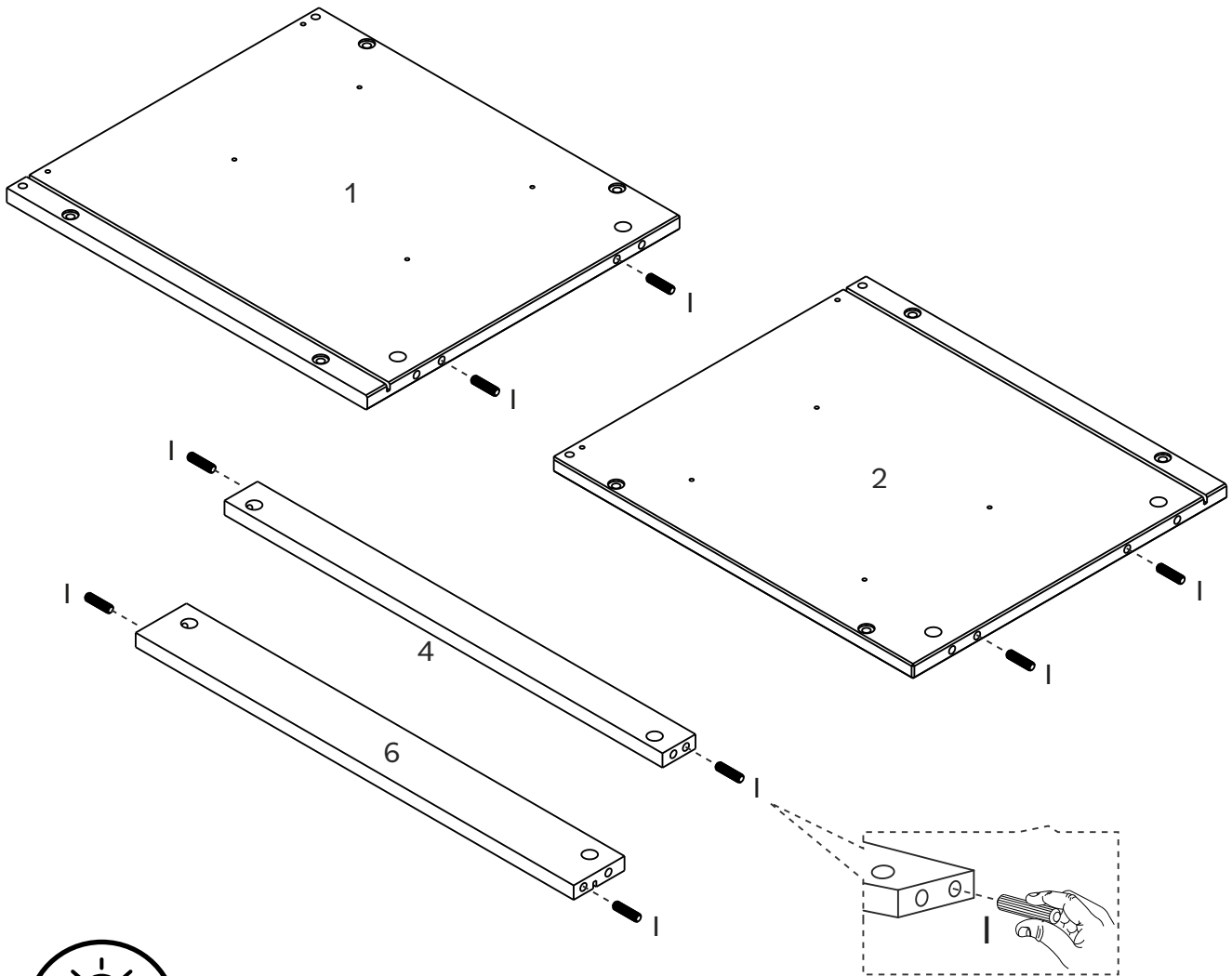

Tip

Wooden Dowel

Dowels are essential in furniture assembly to create strong, precise connections. They ensure structural integrity, prevent shifting, and simplify alignment, resulting in sturdier, longer-lasting furniture.

Follow these steps:

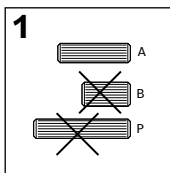

1: Select the appropriate size dowel listed in the step

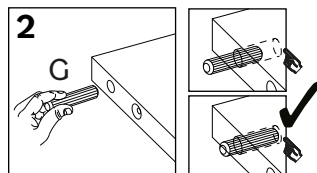

2: Insert into drilled hole and press firmly to ensure placement is set.

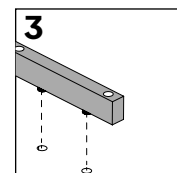

3: Align the dowel with corresponding piece and press together until secure.

Step 10

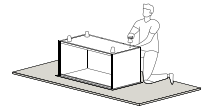

Attach Cam Bolts (J) to Left Panel (1), Right Panel (2) and Top Panel (3).

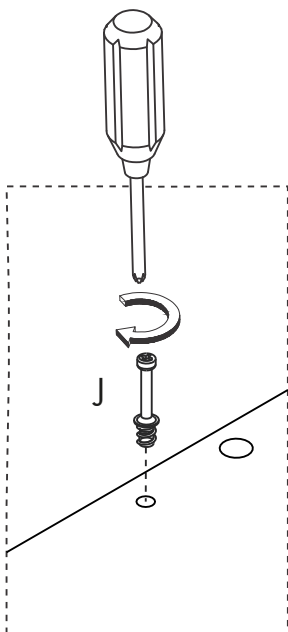
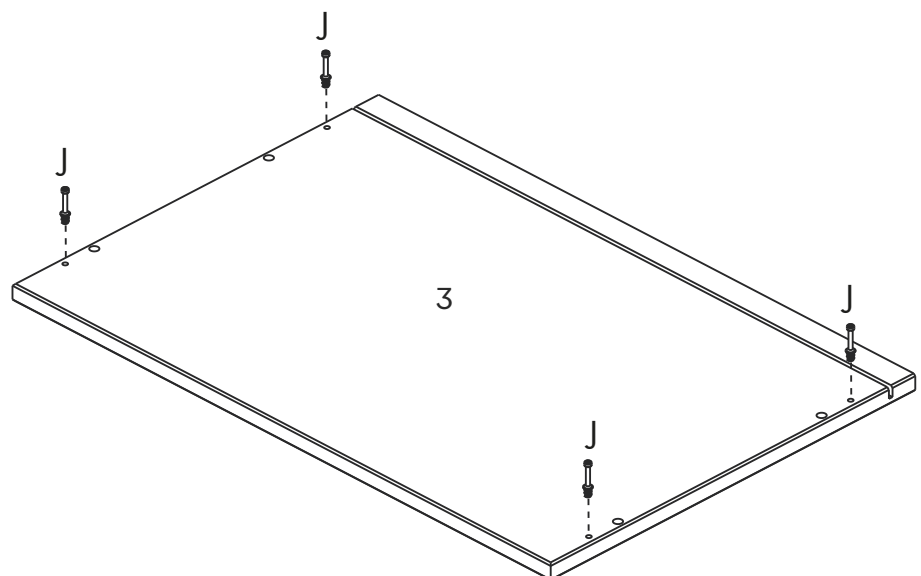
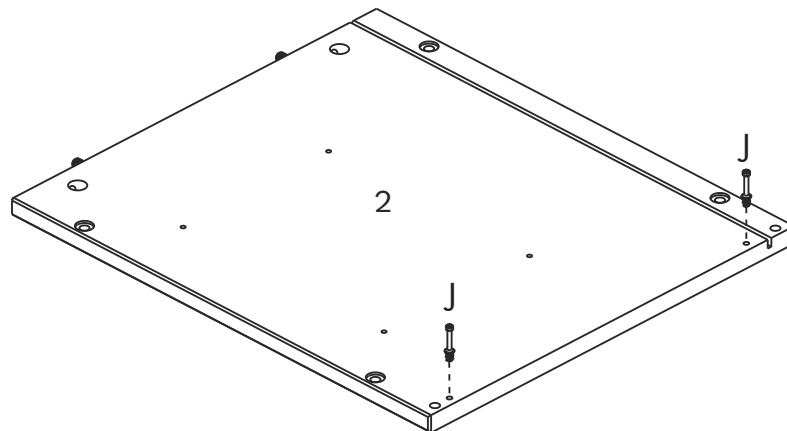
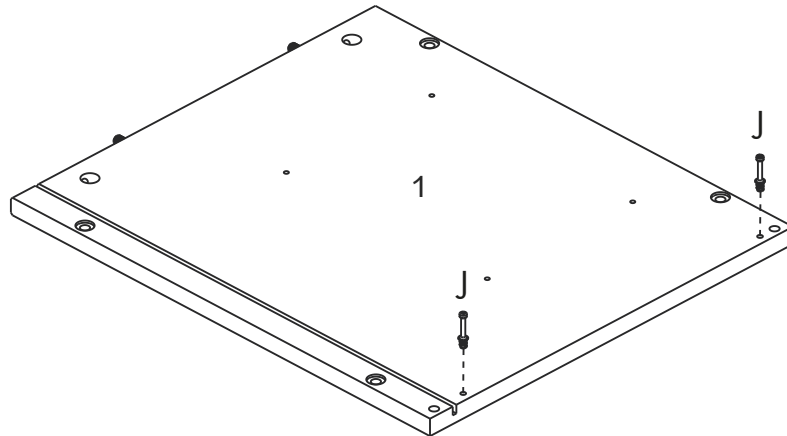

Step 11

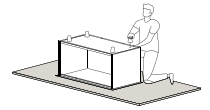

Secure Outer Slider (F1) to Left Panel (1) and Right Panel(2) using Screw (E) and a Phillips screwdriver.

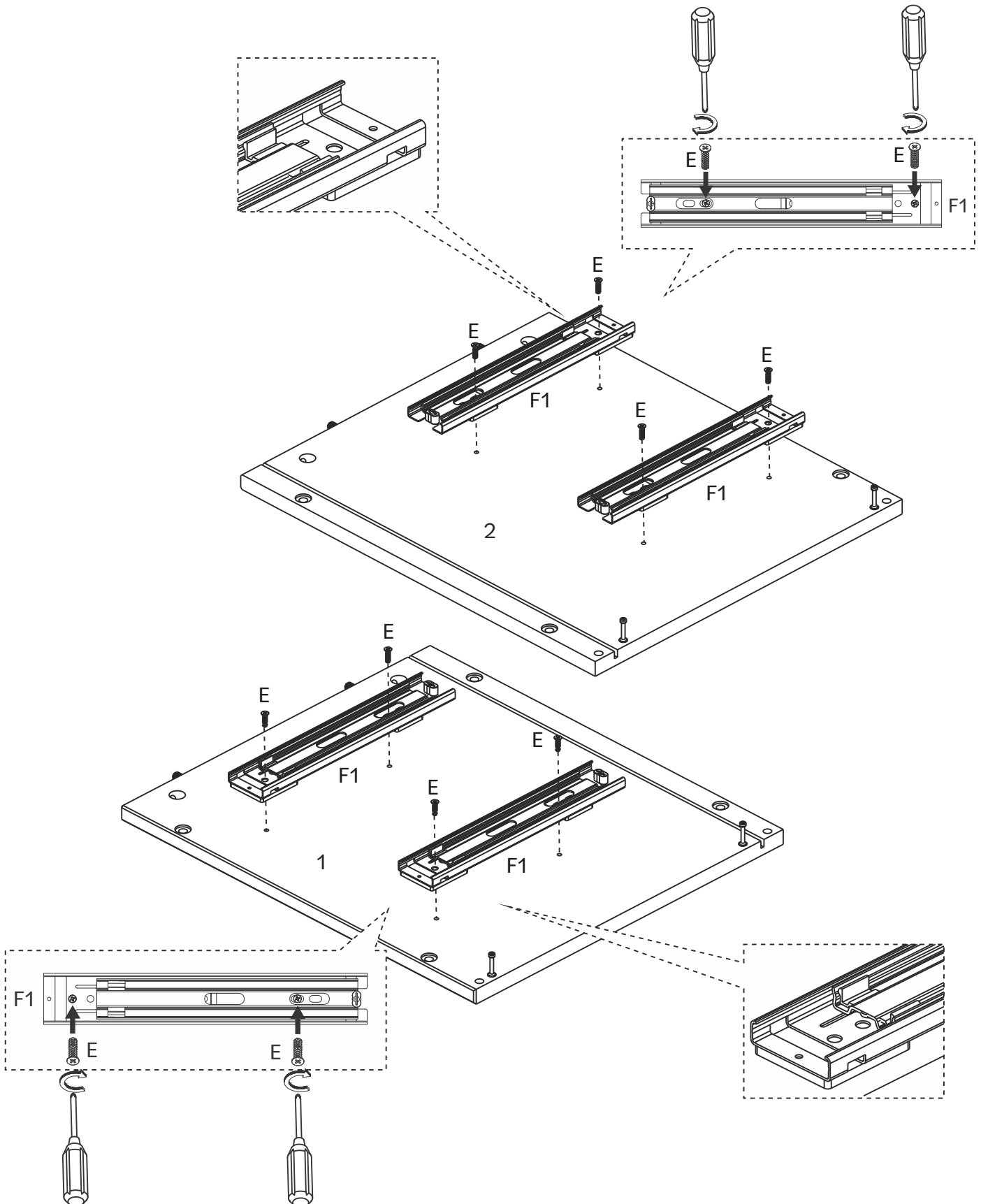

Step 12



Attach Front Rail (4) and Back Rail (6) to Left Panel (1) using Cam Lock (K) and a Phillips screwdriver.

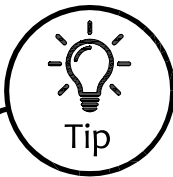
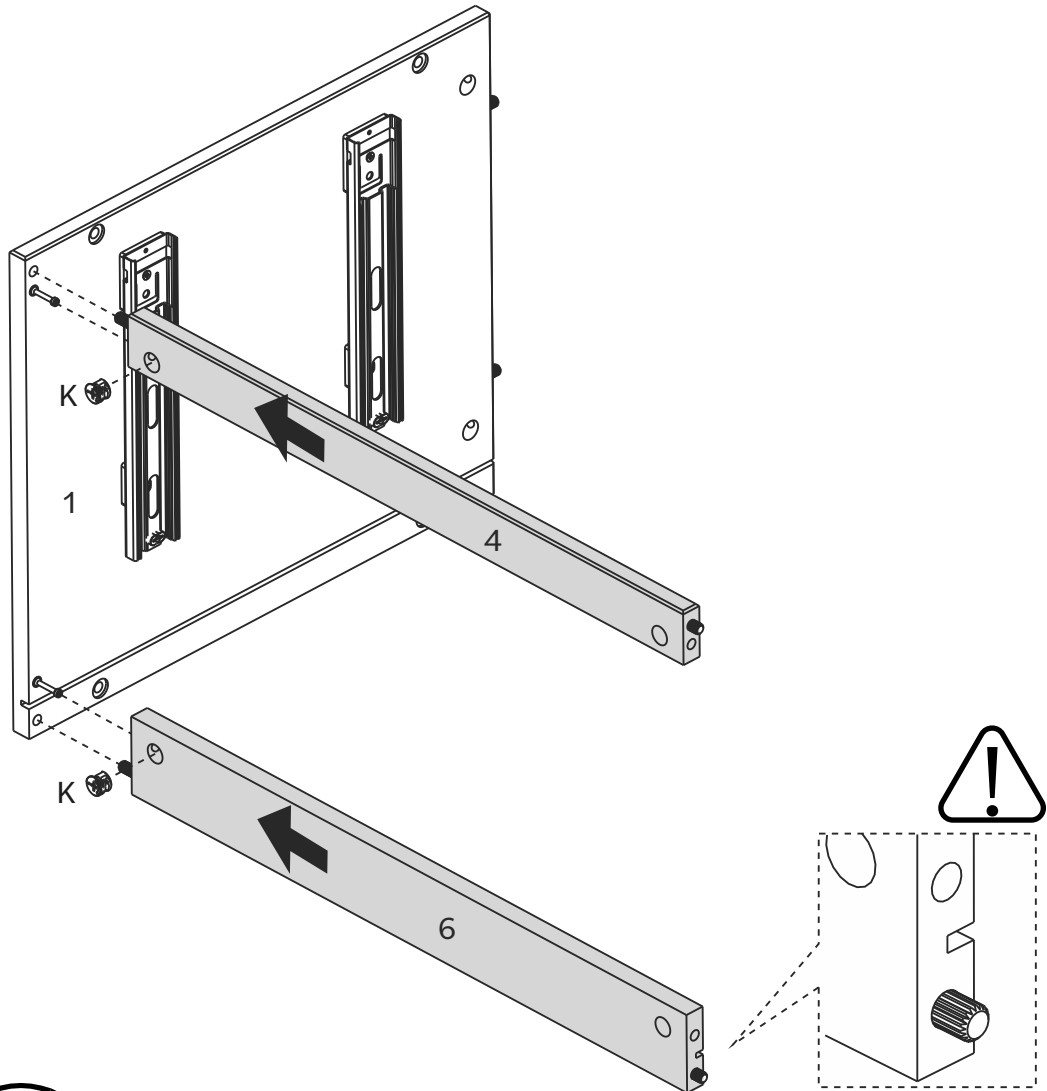

Tip

Cam Locks

Cam Locks help to securely join two pieces together. Follow these easy steps.

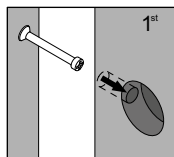

1: Insert Cam Bolt into bolt holes on the flat side. Don't over tighten!

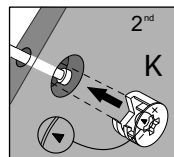

2: Assemble both parts together. The cam bolts go in the drill holes that have a circular hole on the side, you should be able to see the cam bolts through it. After fitting parts together insert the cam lock on the side holes.

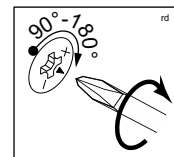

3: On the back of the Cam Lock will be a "C" shape. Insert the Cam Lock so the opening of the "C" fits over the Cam Bolt. Tighten with the screwdriver.

Step 13



Join Right Panel (2) to Front Rail (4) and Back Rail (6) using Cam Lock (K) and a Phillips screwdriver.

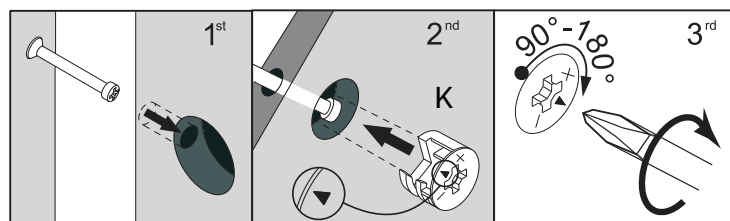
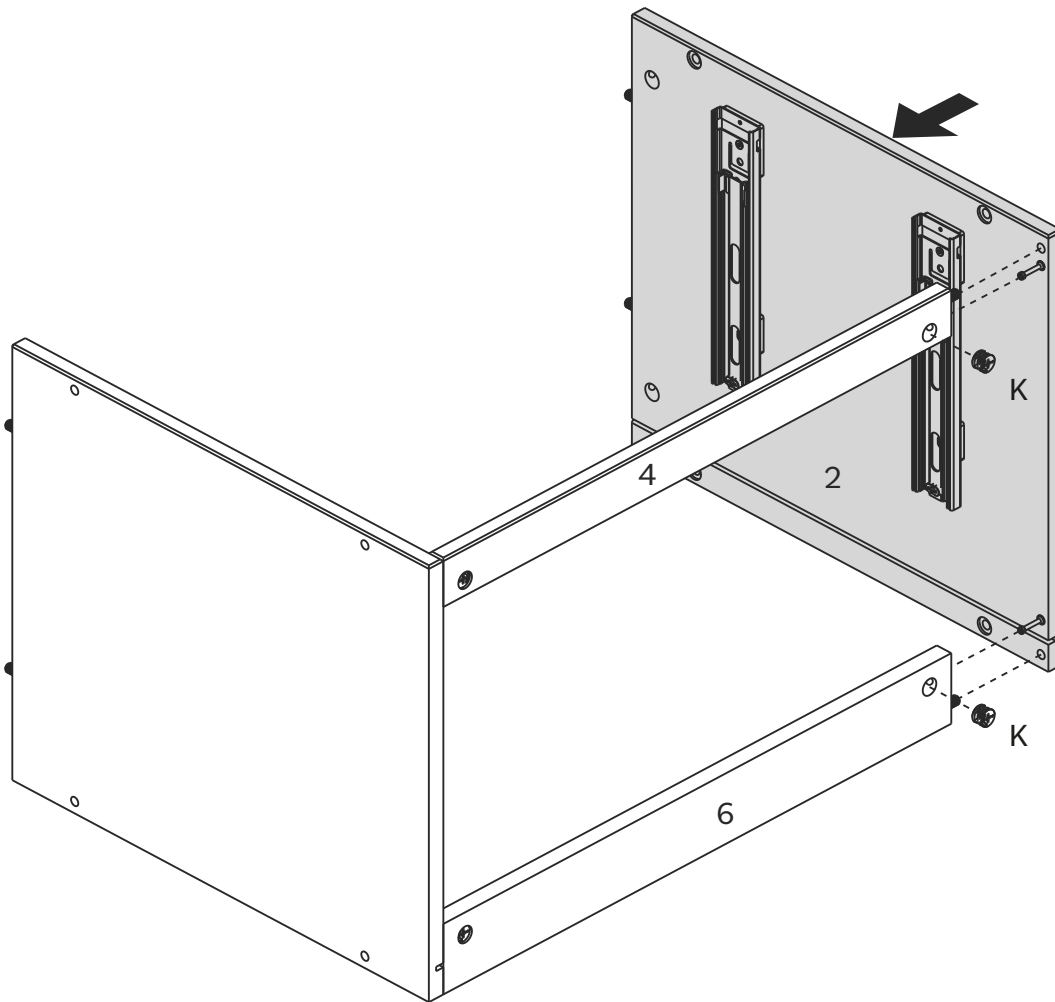

Step 14



Slide Back Panel (9) on the grooves on Left Panel (1) and Right Panel (2), fitting in Back Rail (6).

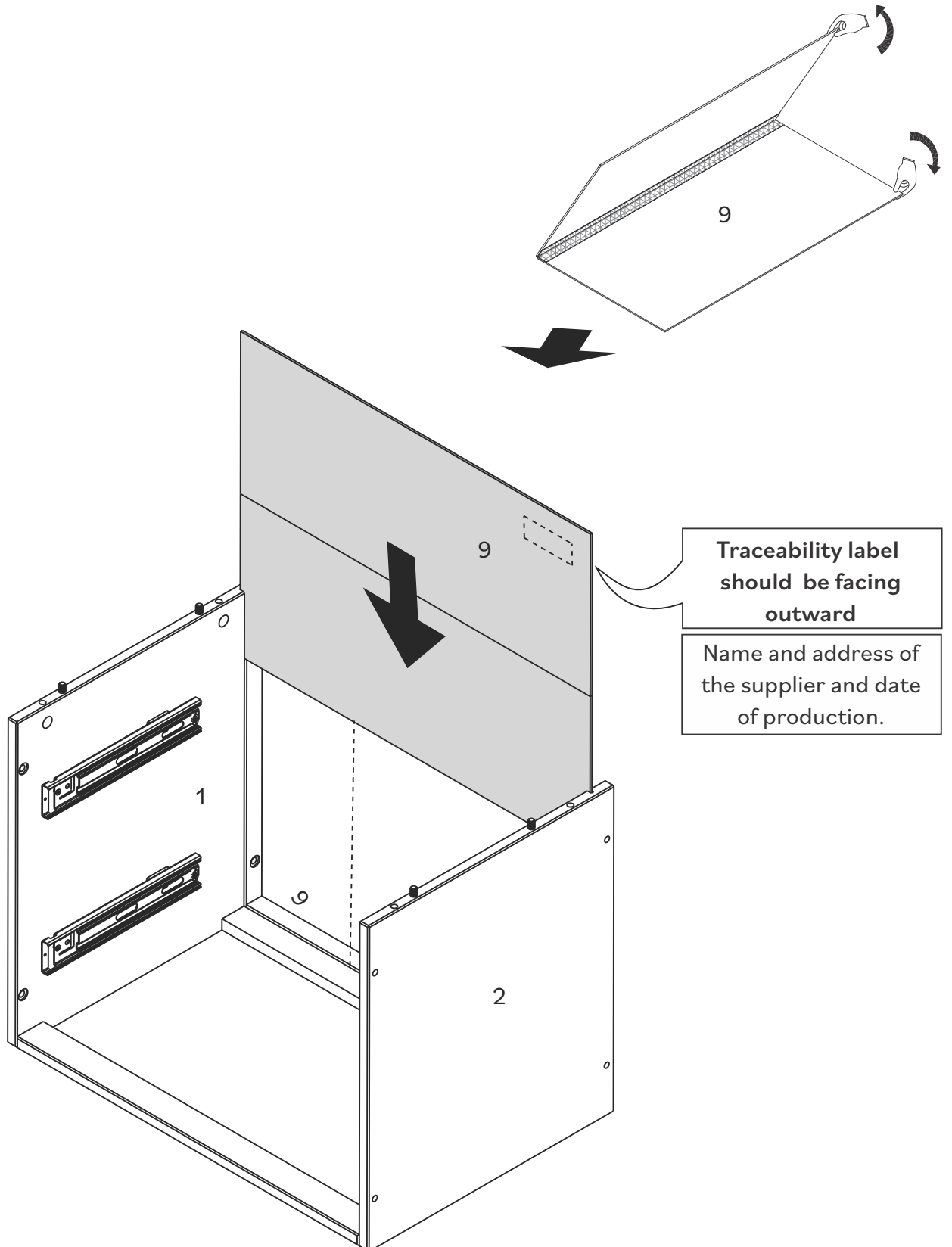

Step 15

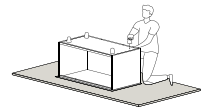

Secure Top Panel (3) to Left Panel (1) and Right Panel (2) using Cam Locks (K) and a Phillips screwdriver.

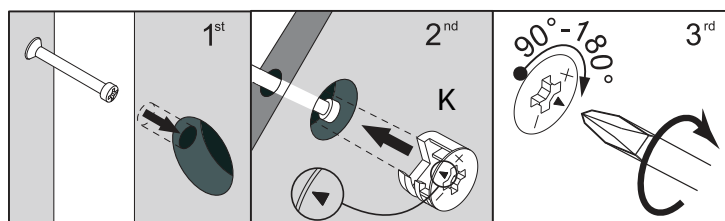
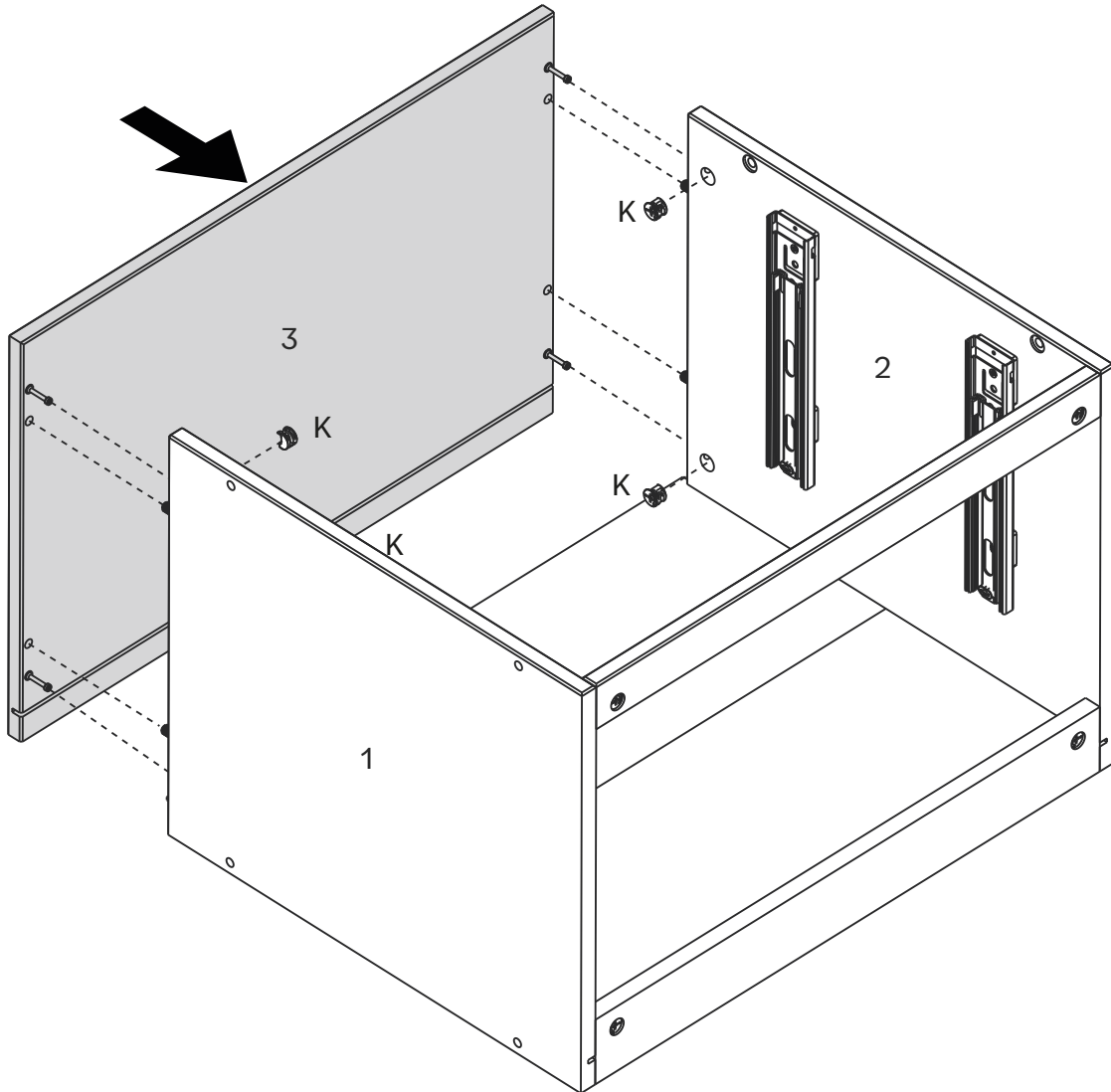

Step 16



Attach Left Foot (8) to Left Panel (1) and Right Foot (7) to Right Panel (2) using Bolt (L) and Hex Key (M).

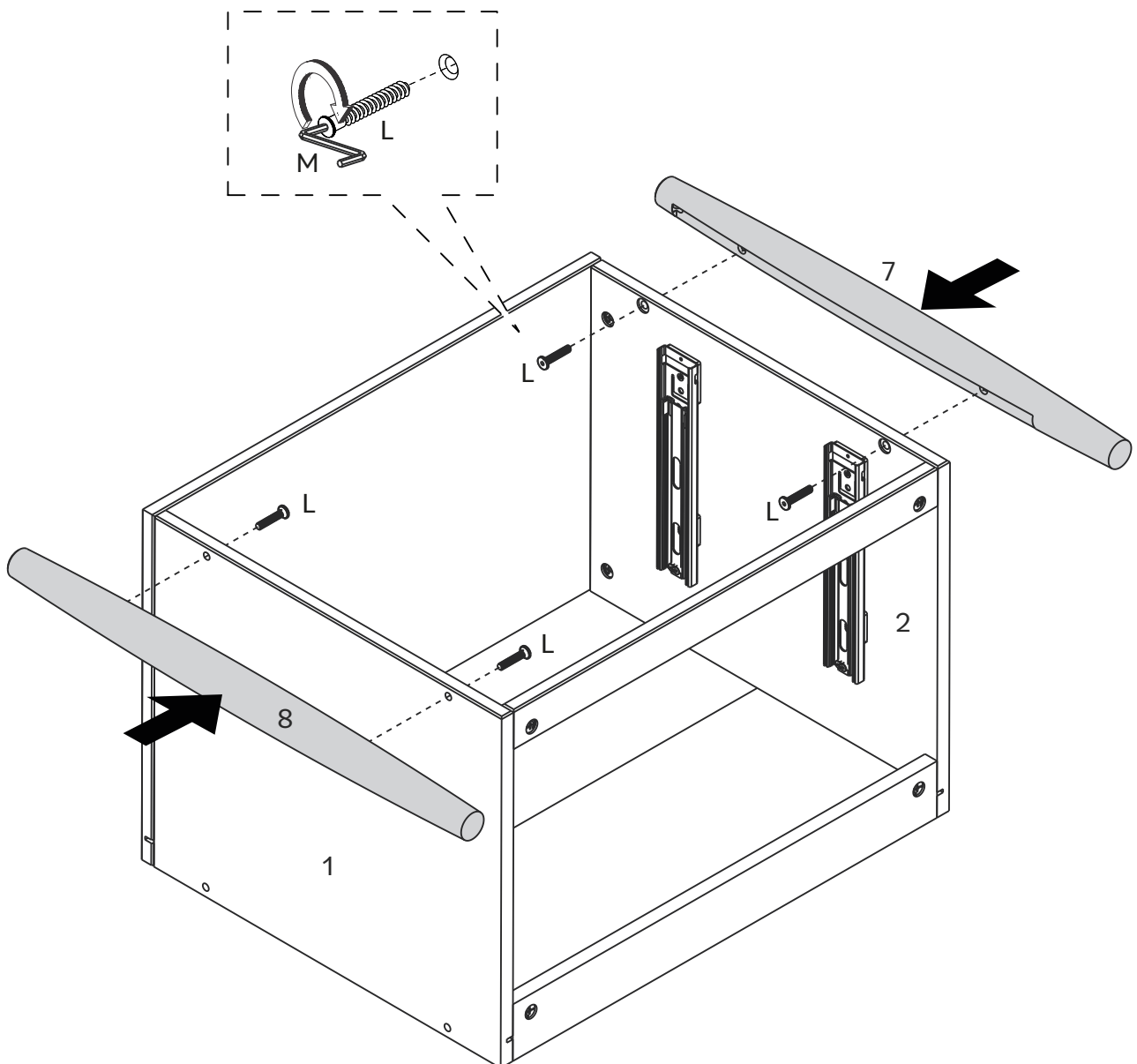

Step 17



On the other end secure Left Foot (8) to Right Panel (2) and Right Foot (7) to Left Panel (1) using Bolt (L) and Hex Key (M).

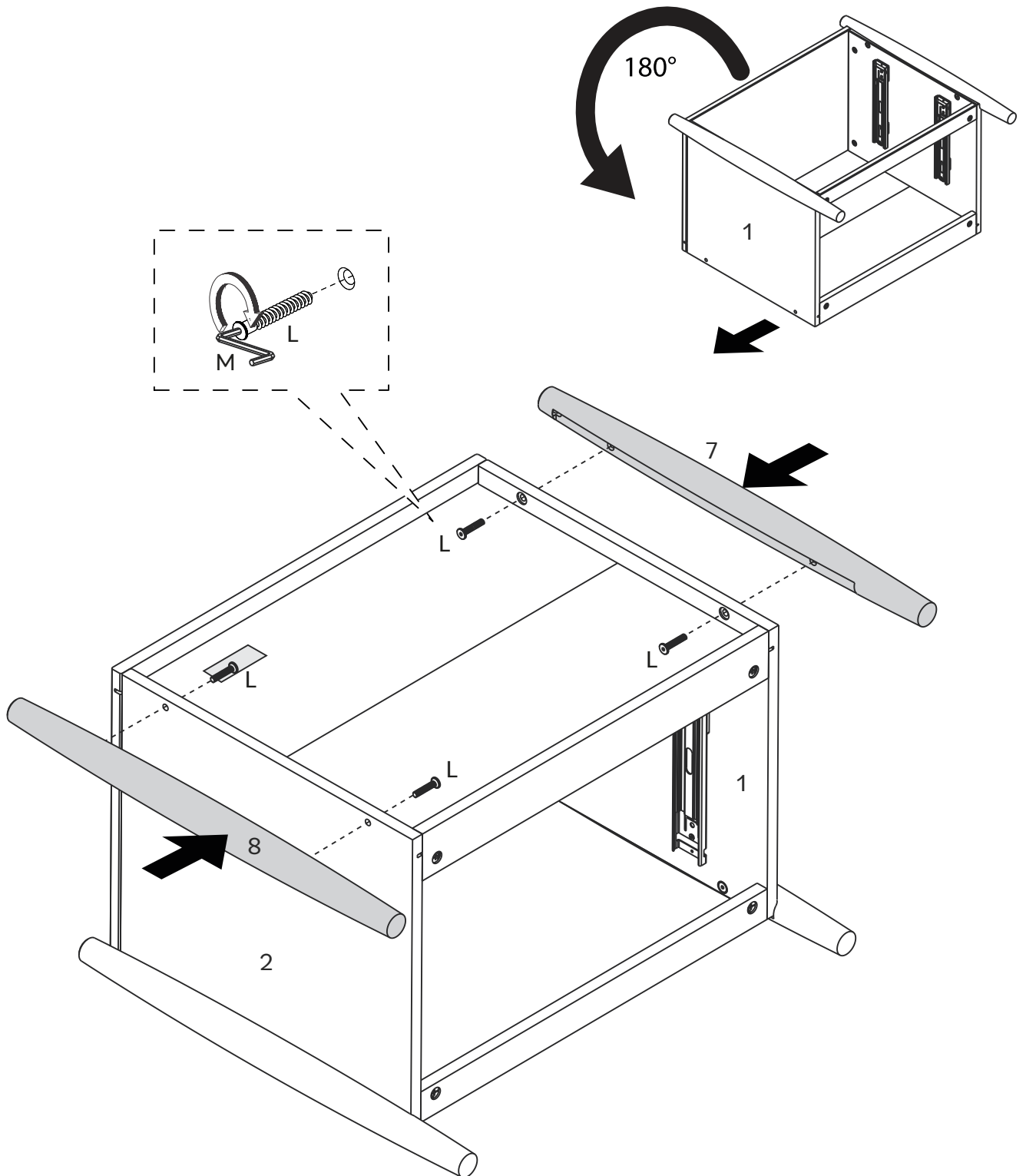

Step 18

Secure Back Panel (9) fitting Wedge (N) and screw (O) between the panel and the grooves. Use and a Phillips screwdriver.

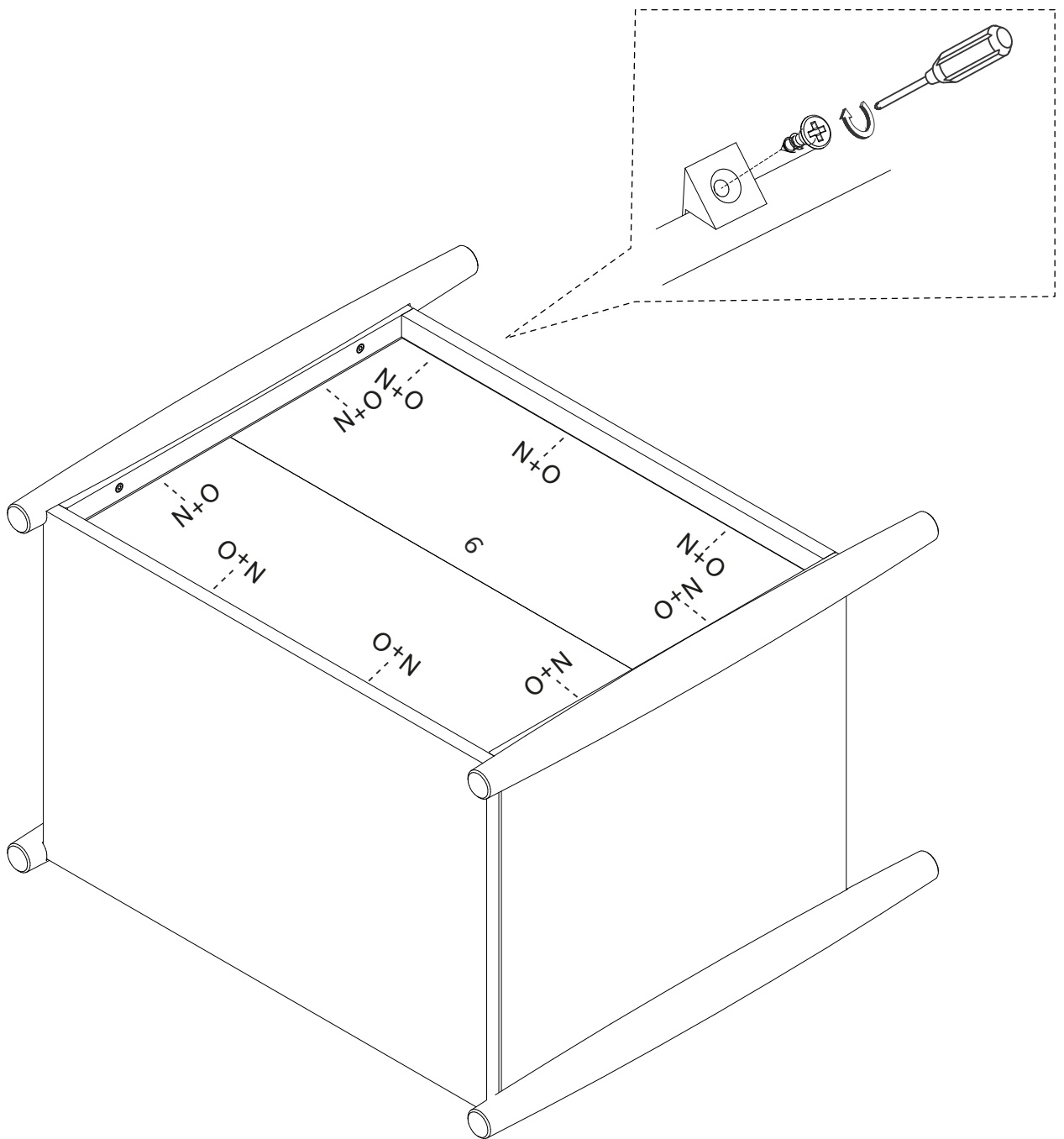

Step 19

Place the Drawers one at a time using the slider, pay attention to position them correctly aligning Outer and Inner Slider.

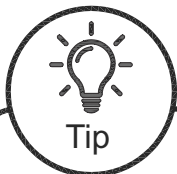
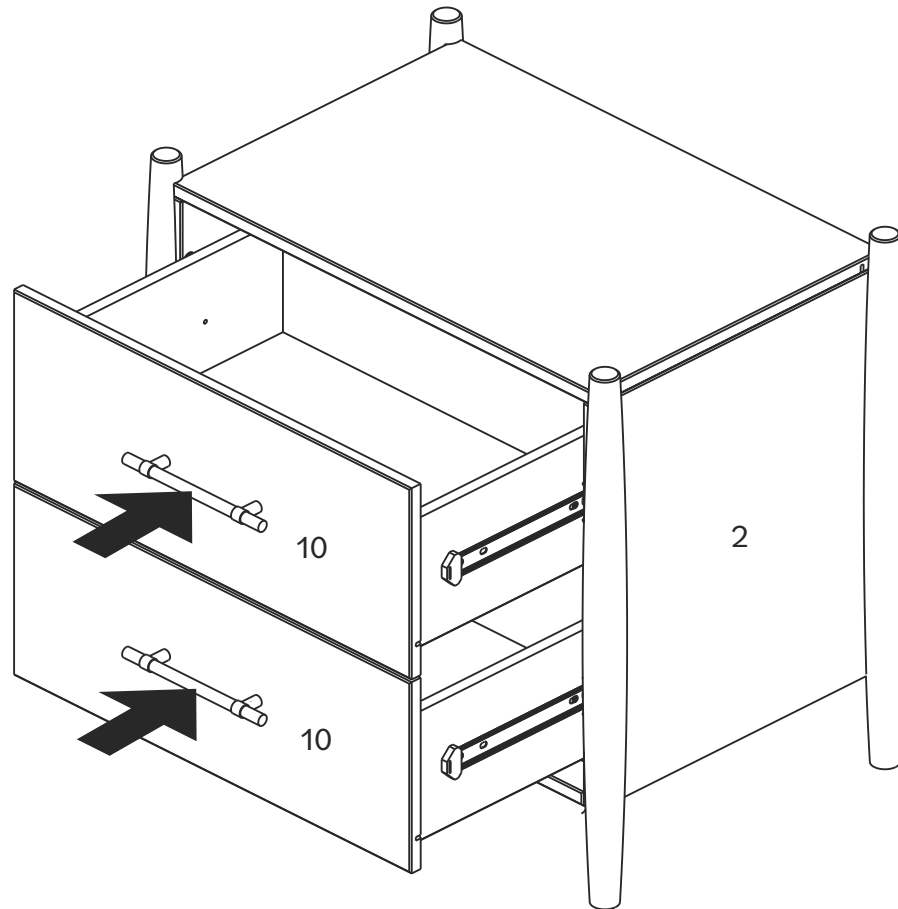

Tip

Insert your Cabinet Drawer Correctly

Line up Outer and Inner Slider and push the drawer slightly inside the unit, once you feel the connection push the drawer entirely into place. It may not be a smooth gliding at first, but it improves once fully connected.

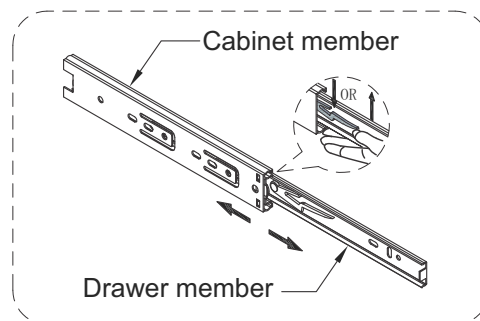

Removing the Drawer

There is a white lever in each slider, to remove the drawers pull the drawer out until you see the lever. Push one lever up and the other down, while pushing, bring the drawer out

To Disassemble



If it is necessary to disassemble, remove the Dovetail locker (B) with a Slotted head screwdriver.

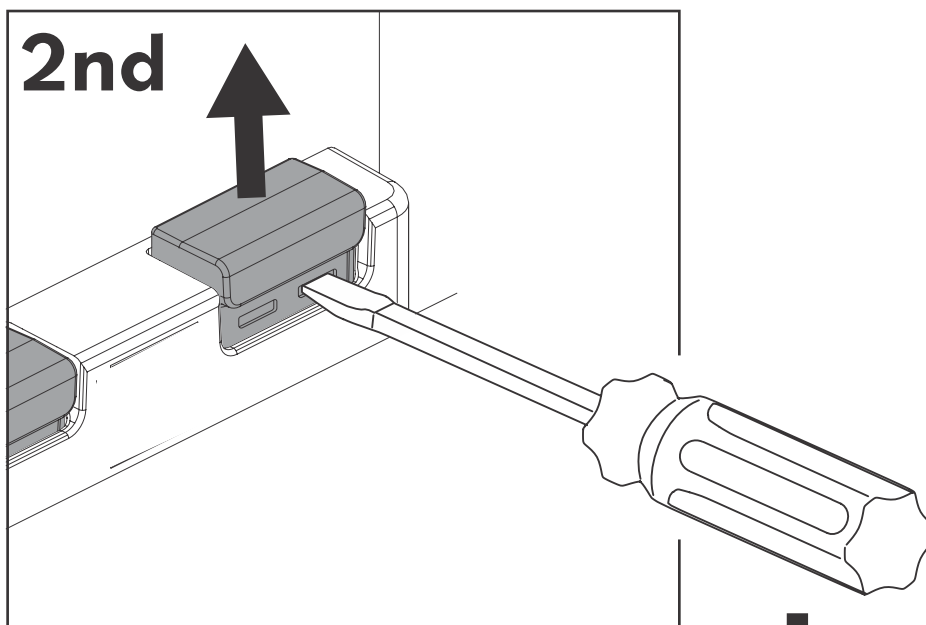
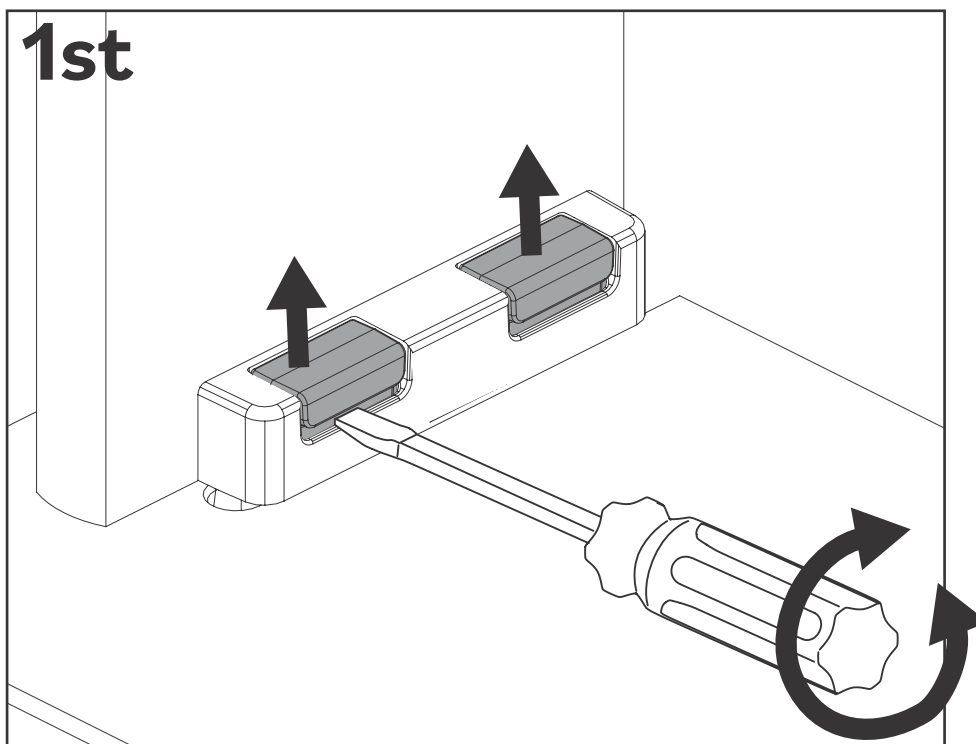

You did it! Enjoy your new Nightstand!

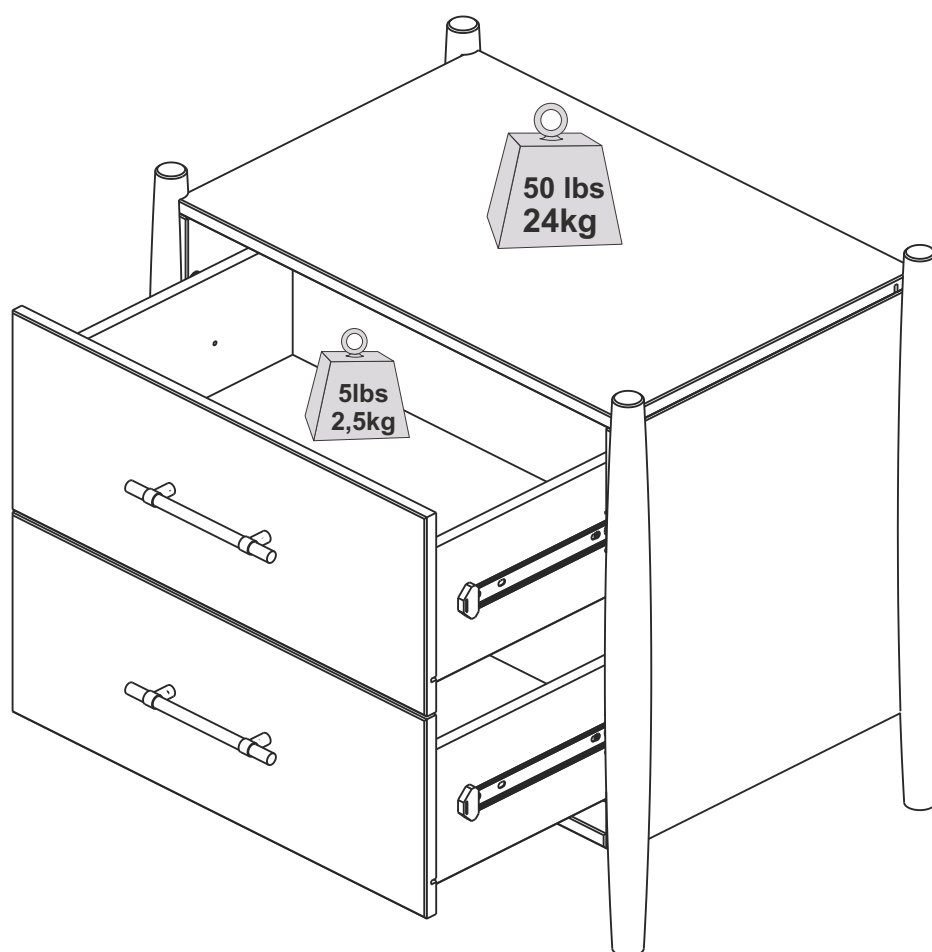

Congratulations on your new piece of furniture!

Table de Chevet à 2 Tiroir Mesita de Noche de 2 Cajone

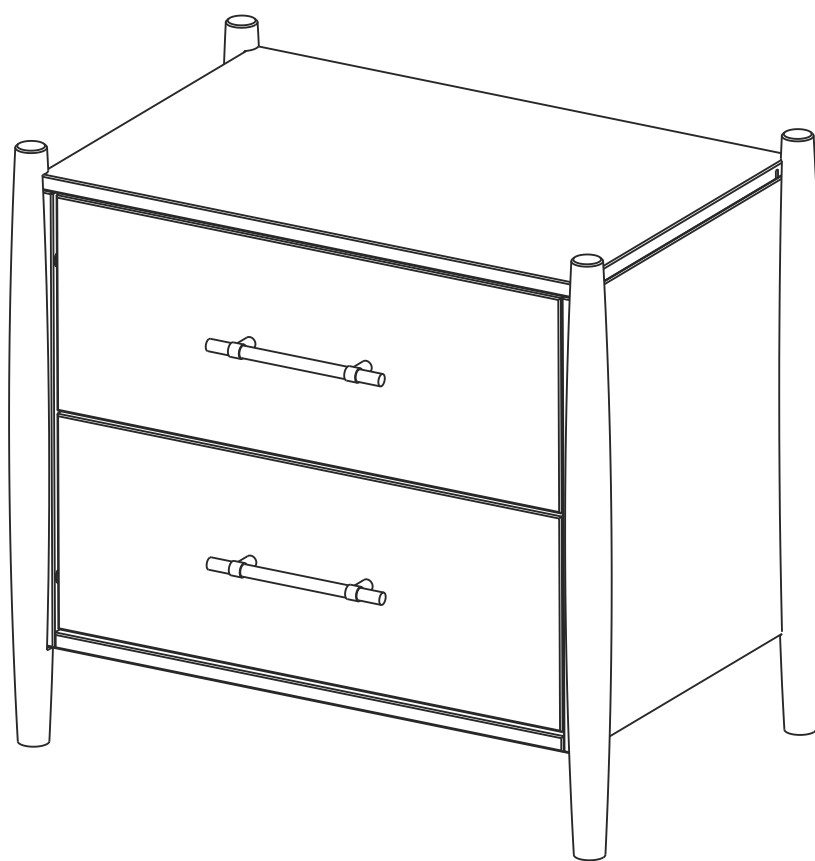

Pour usage résidentiel seulement

Sólo para uso residencial

Il est temps de commencer / Hora de empezar

Prépare un lieu de travail propre et souple pour éviter tout dommage lors de l'assemblage. Tu peux utiliser la boîte et les protections internes comme base. Vérifie également que tu disposes de toutes les pièces et parties avant de te lancer dans l'assemblage.

Prepare un lugar de trabajo limpio y blando para evitar daños durante el montaje. Puede utilizar la caja y las protecciones internas como base. Comprueba también que tiene todas las piezas y partes antes de sumergirse en el montaje.

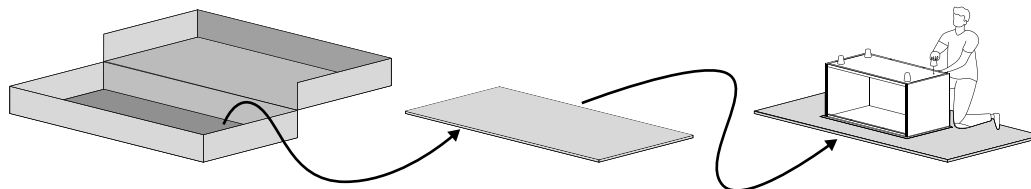

**Temps de montage
estimé**

**Tiempo estimado de
montaje**

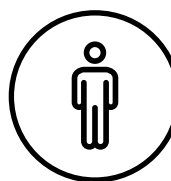

1 Person
1 Person
a

Tu peux le faire assembler seul

Mais vous pouvez en faire un effort d'équipe!

Faites appel à un ami pour une conduite plus rapide et plus facile.

Puedes montarlo solo

¡Pero puedes convertirlo en un esfuerzo de equipo!

Reúne a un amigo para montar más rápido y más fácilmente.

Outils nécessaires

Munis-toi d'un tournevis, tournevis cruciforme et marteau pour réaliser cet assemblage.

Herramientas requeridas

Tome un destornillador, destornillador Phillips y martillo para conquistar este montaje.

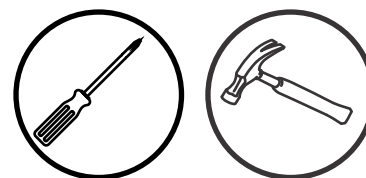

Utilise les outils électriques avec précaution

Ce meuble est réalisé en Bois Massif et Bois Composite, des matériaux souples. Si tu choisis d'utiliser des outils électriques, règle-les sur le mode le plus lent. Fais attention à toi ! Les outils électriques peuvent provoquer des fissures ou endommager les meubles, mais aussi les autres composants s'ils sont mal utilisés.

Utilice las herramientas eléctricas con cuidado.

Este mueble está fabricado con madera maciza y madera compuesta, materiales blandos. Si decide utilizar herramientas eléctricas, ajústelas al ajuste más lento. Tenga cuidado. Las herramientas eléctricas pueden causar grietas o daños en el mueble, pero también en los herrajes si se utilizan mal.

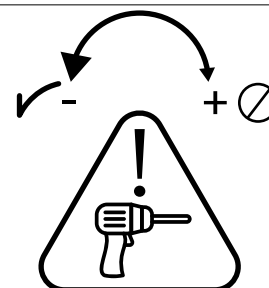





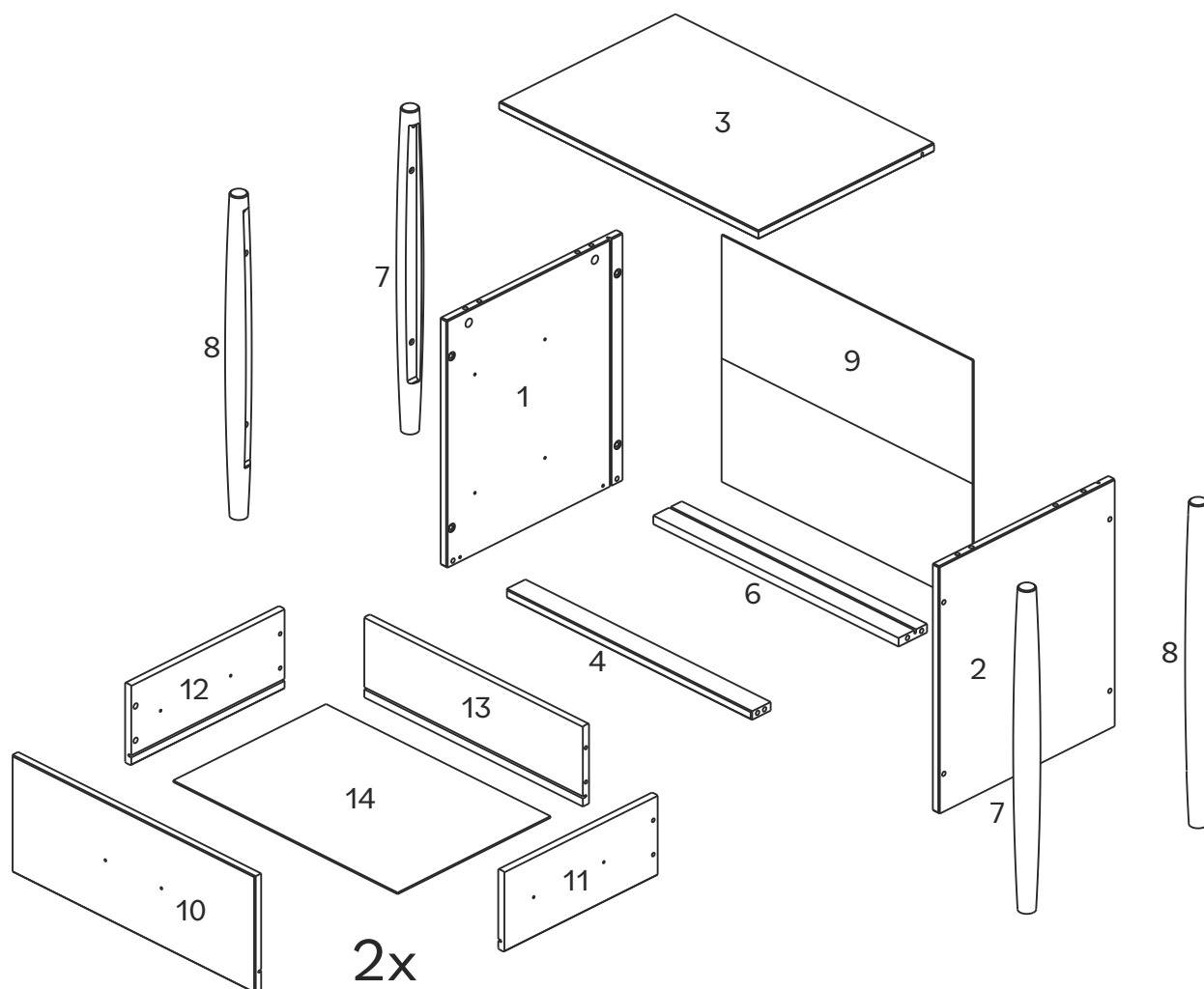







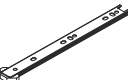

Liste de pièces / Lista de piezas

Nombre de pièces Número de pieza	Description Descripción	Quantité Cantidad
1	Panneau Gauche Panel Izquierdo	1
2	Panneau Droit Panel Derecho	1
3	Panneau Supérieur Panel Superior	1
4	Barre Avant Travesaño Delantero	1
6	Barre Arrière Travesaño Trasero	1
7	Pied Droit Pie Derecho	2
8	Pied Gauche Pie Izquierdo	2
9	Panneau Arrière Panel Trasero	1
10	Façade du Tiroir Frente del Cajón	2
11	Arrière du Tiroir Trasero del Cajón	2
12	Fond du Tiroir Fondo del Cajón	2
13	Côté Droit du Tiroir Lado Derecho del Cajón	2
14	Côté Gauche du Tiroir Lado Izquierdo del Cajón	2

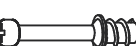

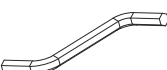
Liste de composants / Lista de hardware

Partie Parte	Taille Tamaño	Nom Nombre	Quantité Cantidad
A 		Dovetail Dovetail	4
B 		Dovetail Verrrous Dovetail Traba	8
C 		Vis Plastique Tornillo Plástico	8
D 	6x12mm	Vis Tornillo	8
E 	6x14mm	Vis Tornillo	8
F1 	250mm	Glissière Exterior Corredera Exterior	4
F2 	250mm	Glissière Intérieur Corredera Interior	4
G 		Poignée Manija	2
H 	3,5x30mm	Vis Tornillo	4
I 	8x30mm	Cheville Espiga	8
J 	6x31mm	Goujon Conector	8
K 	15x11mm	Boitier Traba	8
L 	7x35mm	Boulon Perno	8
M 		Clé Hex Llave Hex	1
N 		Wedge Wedge	10
O 	3,5X14mm	Screw	10

Les quantités de composants indiquées ci-dessus sont nécessaires pour un assemblage correct.

Des pièces supplémentaires peuvent être incluses.

Las cantidades de tornillería indicadas anteriormente son necesarias para un montaje correcto.

Se pueden incluir piezas de ferretería adicionales.

Introducing The Easy Assembly Drawer System

Say Goodbye to Assembly Hassle!

We understand that assembling drawers can be the most time-consuming and tedious part of putting together your new furniture. That's why we've developed the Easy Assembly Drawer System - to make the process easy!

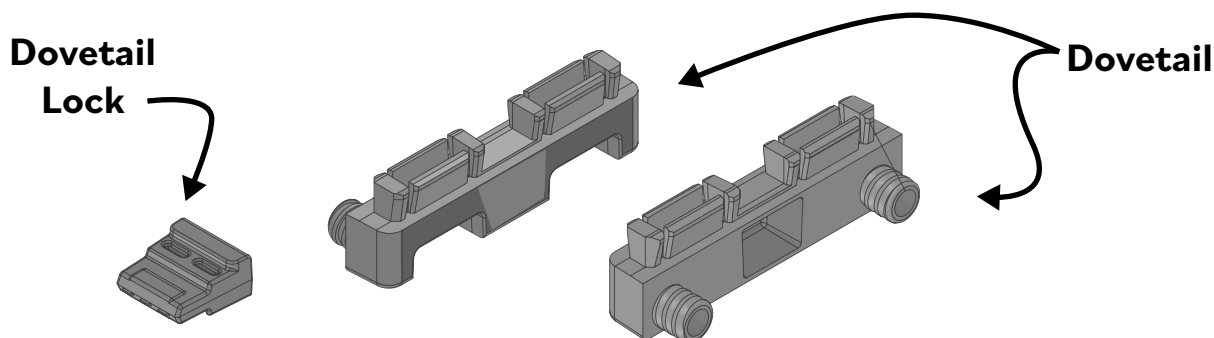

Why You'll Love Our Easy Assembly Drawer System:

Quick & Easy: Our new drawer hardware significantly reduces your assembly time. Get it done in no time!

Minimal Effort Required: Designed to be super simple, you'll need little to no tools to get the job done.

Built to Last: Strong and sturdy, our system ensures that your drawers stay solid and reliable.

Let's set the stage to assembly:

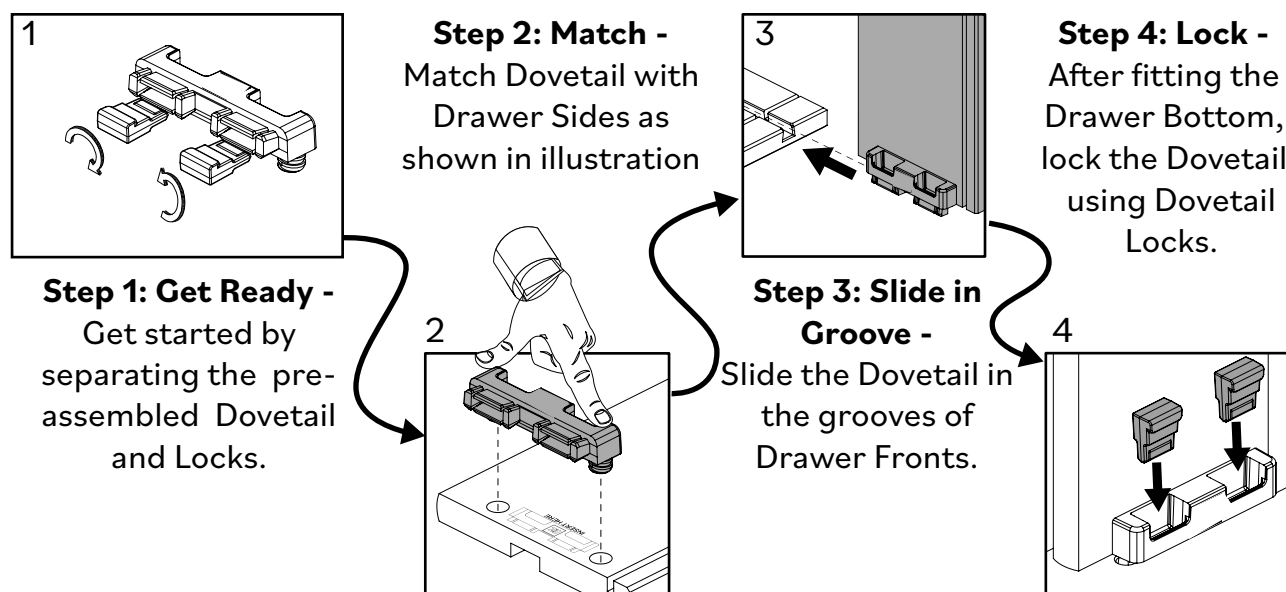

Attention: In the next steps there are more details to help you assemble.

Étape / Paso 1

(FR)

Préparez les Dovetails (A) en retirant les Dovetail verrous (B) des Dovetails (A).

(ES)

Prepare las Dovetails (A) quitando las Trabas del Dovetail (B) de los Dovetails (A).

1st

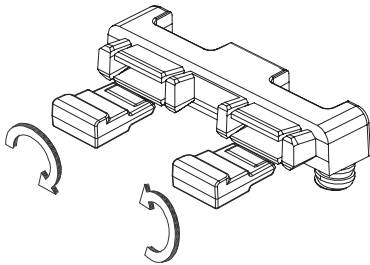

2nd

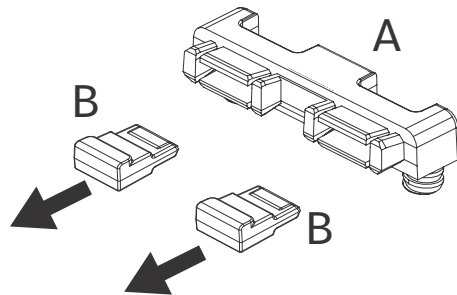

Étape / Paso 2

(FR)

Enclenchez les Dovetails (A) sur le côté droit (11) et gauche (12) du tiroir. Appuyez sur les Dovetails jusqu'à ce qu'elles soient bien fixées. Utilisez un marteau si nécessaire.

(ES)

Coloque los Dovetails (A) en su lugar en el laterale del cajón derecho (11) y del cajón izquierdo (12). Presione los Dovetails hasta que queden completamente fijadas. Use un martillo si es necesario.

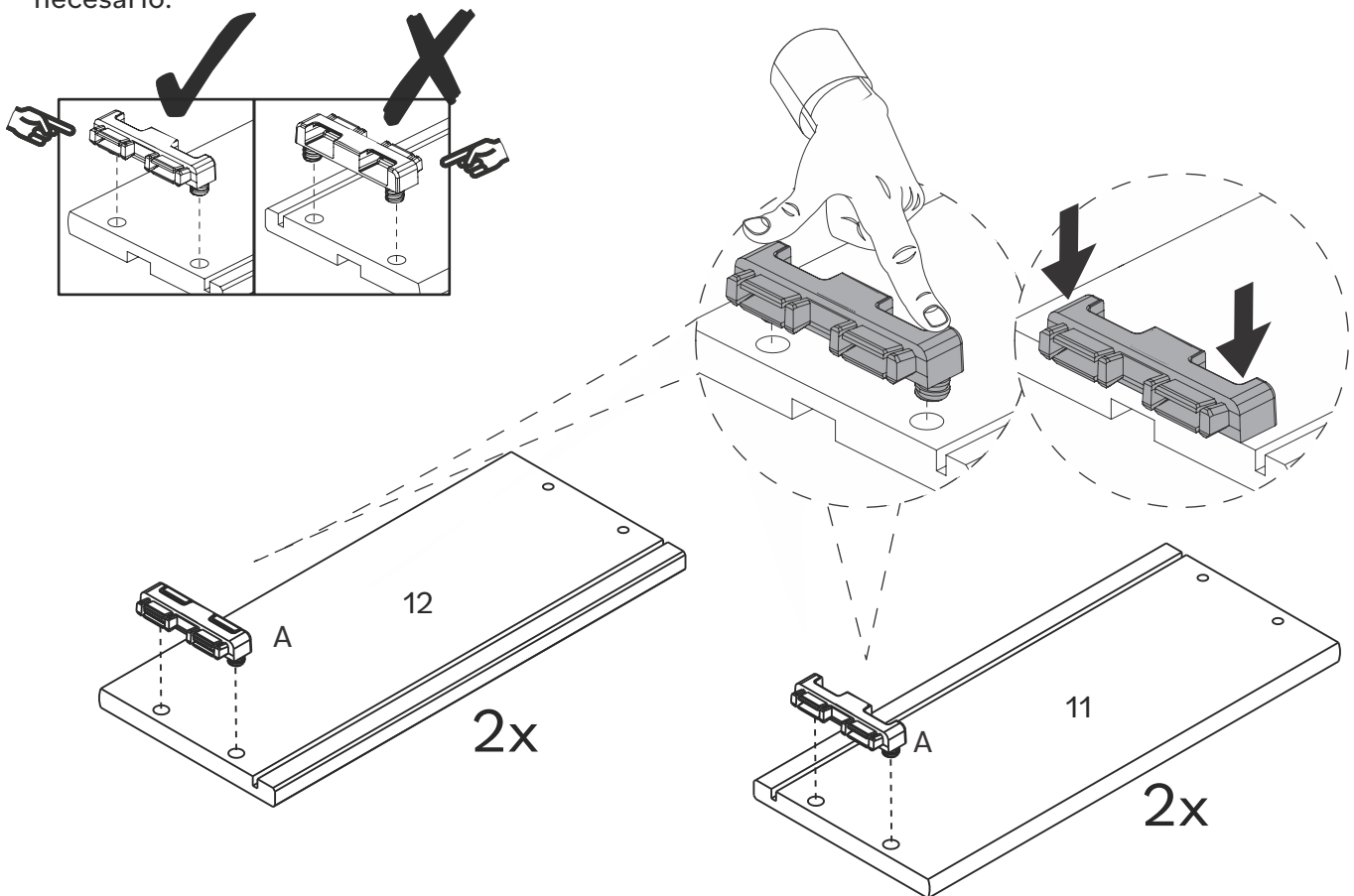

Étape / Paso 3

(FR)

Faites glisser la dovetail (A) du côté droit du tiroir (11) et du côté gauche du tiroir (12) dans les rainures de la façade du tiroir (10).

(ES)

Deslice la Dovetail (A) del lado derecho del cajón (11) y del lado izquierdo del cajón (12) en las ranuras del frente del cajón (10).

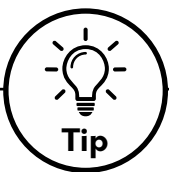
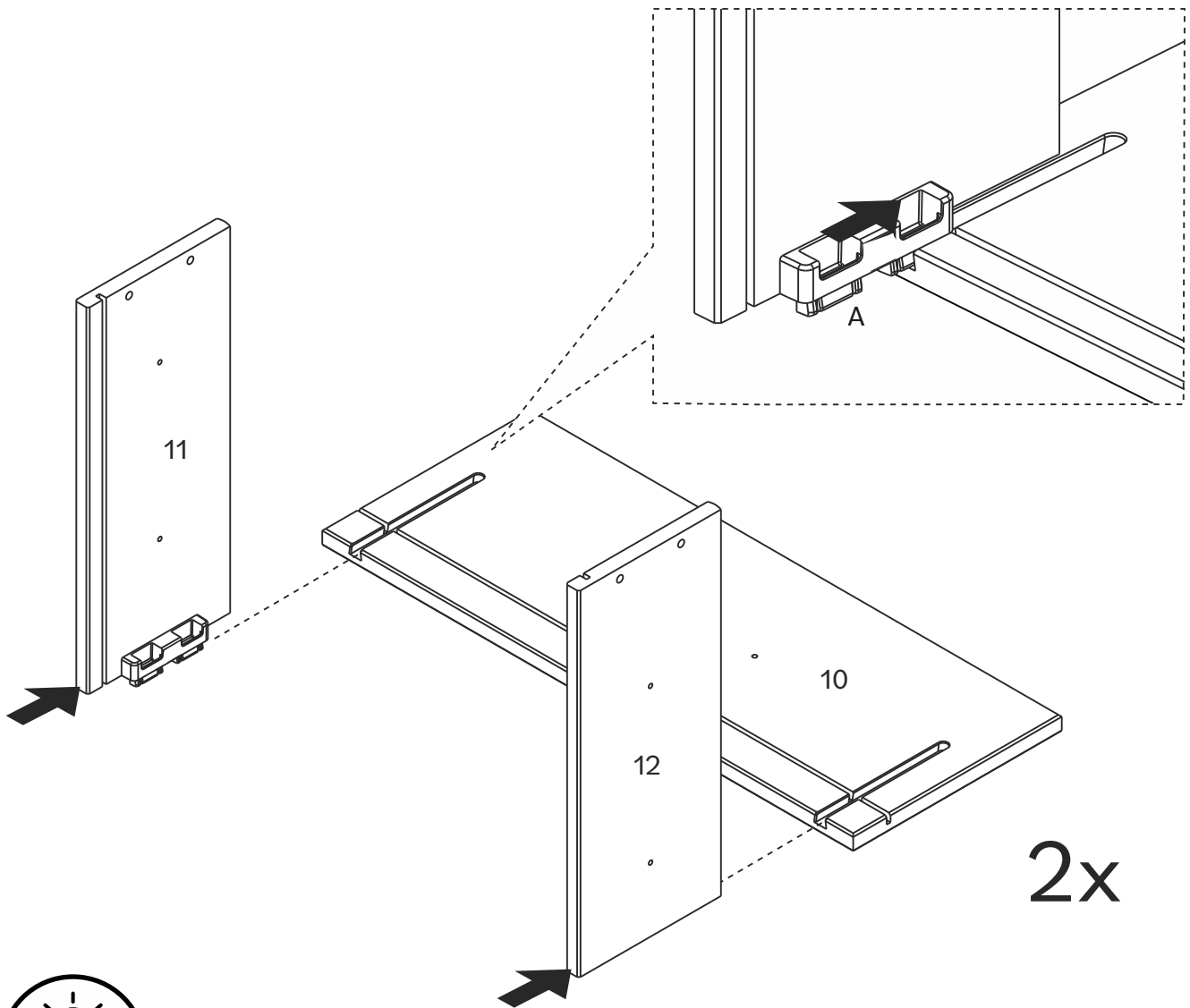

Tip

Pour que ton produit conserve son meilleur aspect et sans rayures, essaie de le monter sur une surface souple telle qu'un tapis ou une couverture. Cela permet d'éviter les rayures accidentelles et de garder tes meubles en bon état !

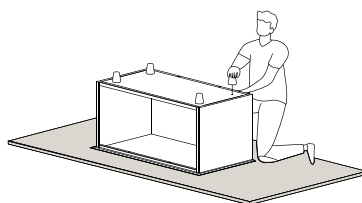

Para mantener su producto con el mejor aspecto y sin arañazos, pruebe a montarlo sobre una superficie blanda, como una alfombra o una manta. Así evitará arañazos accidentales y mantendrá sus muebles en perfecto estado.

Étape / Paso 4

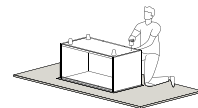

(FR)

Faites glisser le fond du tiroir (14) dans les rainures du cote droit (11), du côté gauche (12) et de la façade du tiroir (10).

(ES)

Deslice el fondo del cajón (14) en las ranuras del lado derecho (11), el lado izquierdo (12) y el frente del cajón (10).

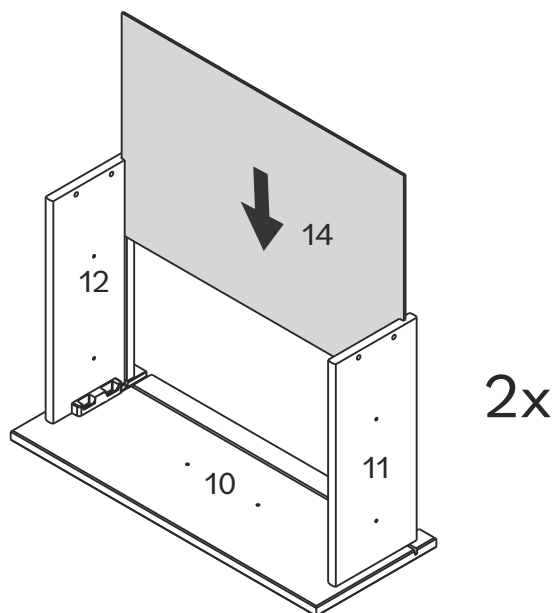
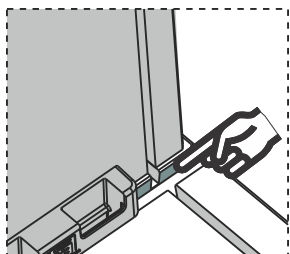

Alignez les rainures sur les côtés et le devant du tiroir pour recevoir le fond du tiroir

Alinee las ranuras en los lados y el frente del cajón para recibir la parte inferior del cajón.

Étape / Paso 5

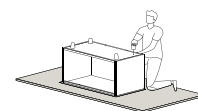

(FR)

Pour fixer les côtés du tiroir, insérez les Dovetails verrous (B) dans les Dovetails (A). Utilisez un marteau si nécessaire.

(ES)

Para asegurar los laterales del cajón, inserte las Trabas del Dovetail (B) en las dovetails (A). Use un martillo si es necesario.

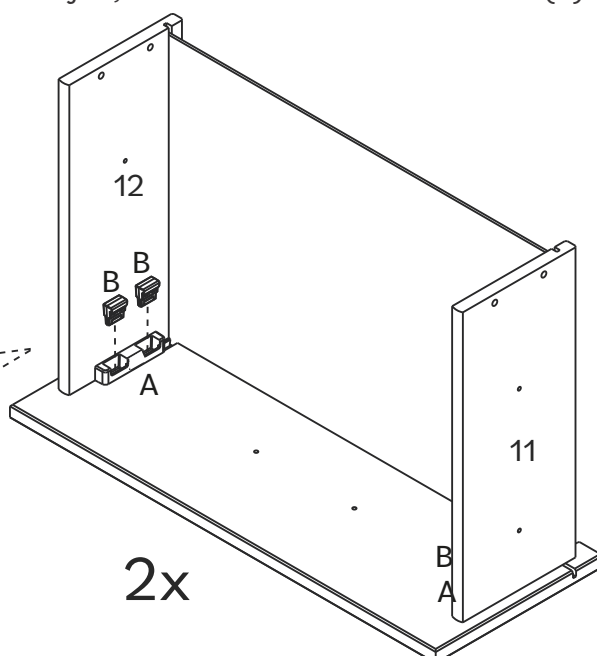
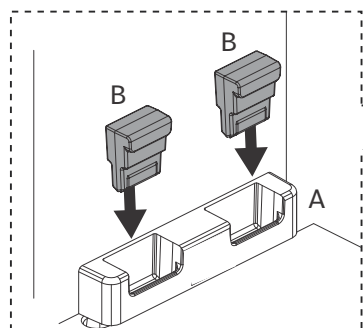

Étape / Paso 6



(FR)

Fixez le fond du tiroir (10) au arrière du tiroir (9) et fixez-le à l'aide de la vis en plastique (C). Vous pouvez l'insérer avec vos mains ou à l'aide d'un marteau..

(ES)

Coloque el fondo del cajón (12) en el trasero del cajón (11) y asegúrelo con el tornillo de plástico (C), puede insertarlo con las manos o con un martillo.

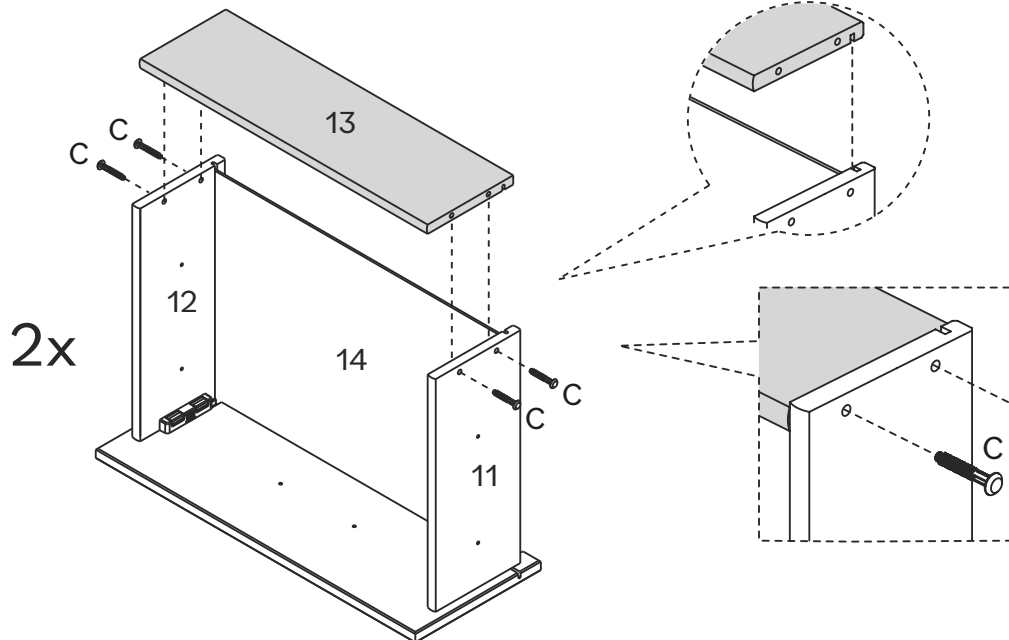

Étape / Paso 7



(FR)

Fixez le fond du tiroir (10) au arrière du tiroir (9) et fixez-le à l'aide de la vis en plastique (C). Vous pouvez l'insérer avec vos mains ou à l'aide d'un marteau..

(ES)

Coloque el fondo del cajón (12) en el trasero del cajón (11) y asegúrelo con el tornillo de plástico (C), puede insertarlo con las manos o con un martillo.

Séparer les parties F1 et F2 en appuyant sur le verrou.

Separar las piezas F1 y F2 presionando el bloqueo .

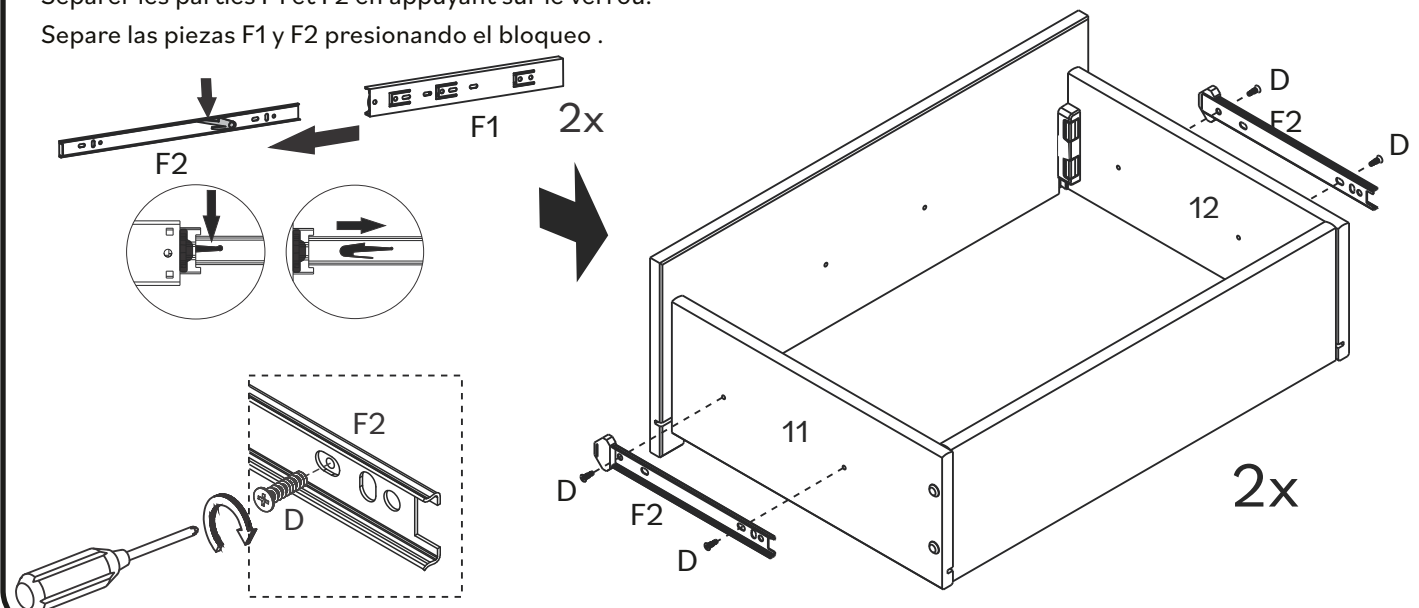

Étape / Paso 8

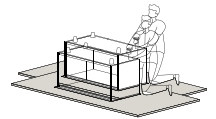

(FR)

Utilisez des vis (H) et un tournevis cruciforme pour fixer les poignées (G) a façade du tiroir (10).

(ES)

Utilice tornillos (H) y un destornillador Phillips para asegurar las manijas (G) a la frentes del cajon (10)

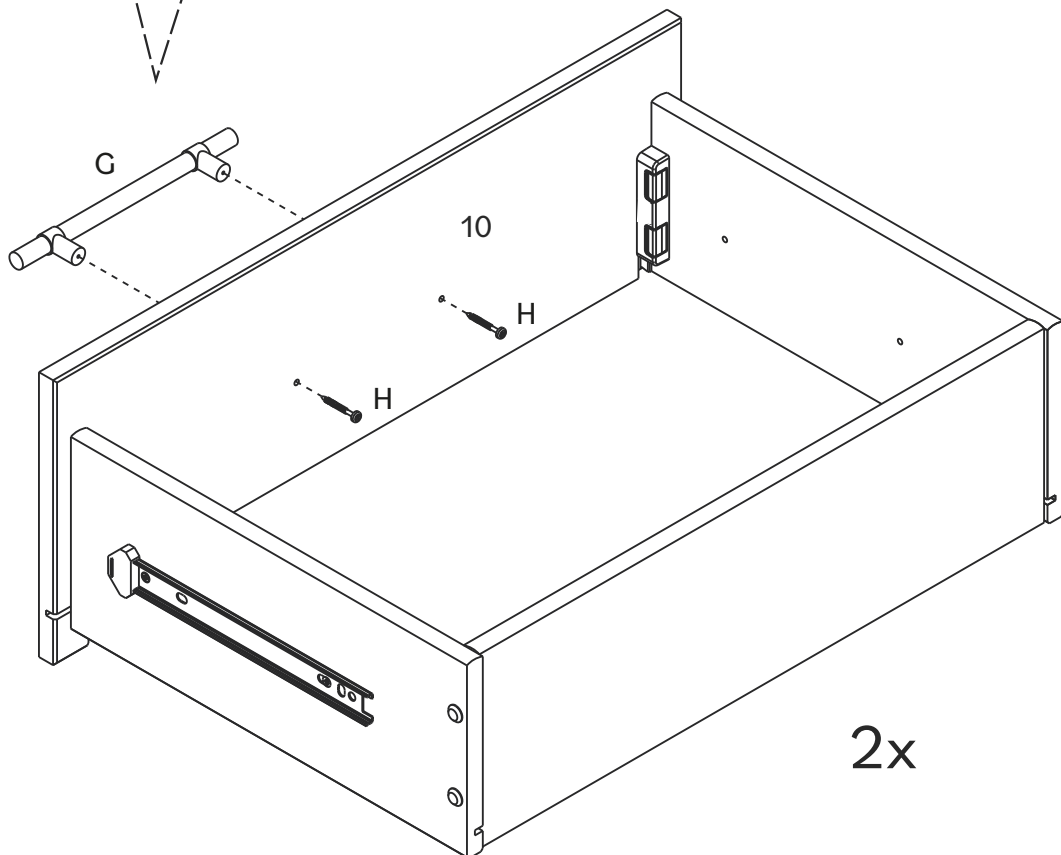
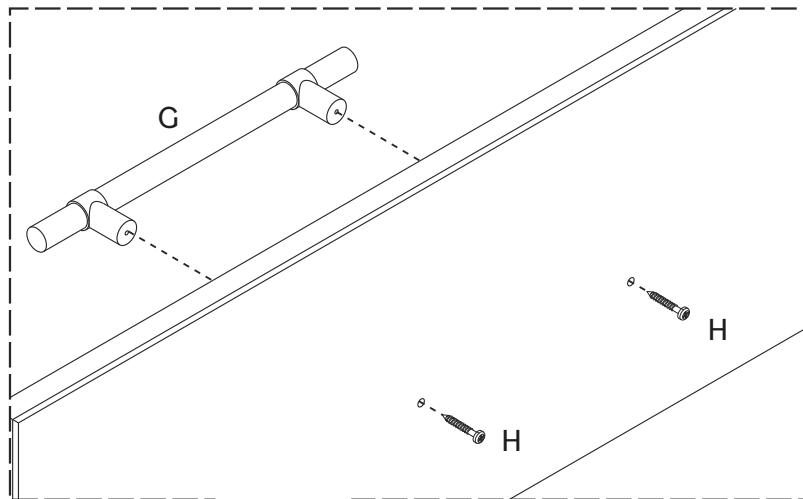

Étape / Paso 9

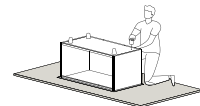

(FR)

Commençons l'assemblage ! Insérez les chevilles en bois (G) dans le panneau droit (1), le panneau gauche (2), la barre avant (4) et la barre arrière (6).

(ES)

¡Comencemos con el montaje! Inserte las espigas (G) en el panel derecho (1), el panel izquierdo (2), travesaño avant (4), travesaño trasero (6).

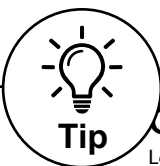
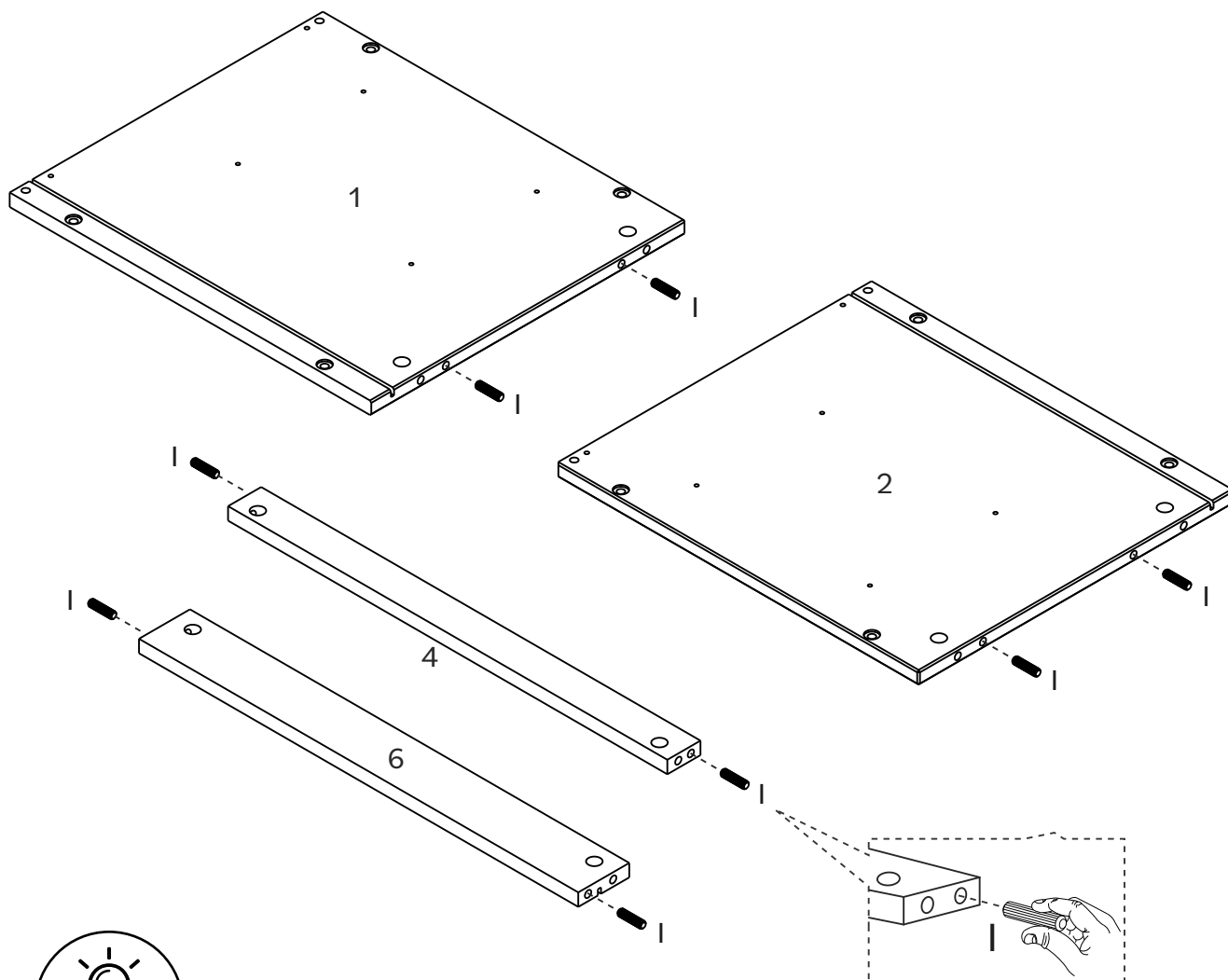

Tip

Cheville en bois

Les chevilles sont essentielles lors de l'assemblage de meubles pour créer des connexions solides et précises. Elles garantissent l'intégrité structurelle, empêchent les déplacements et simplifient l'alignement, ce qui permet d'obtenir des meubles plus résistants et plus durables. suis ces étapes :

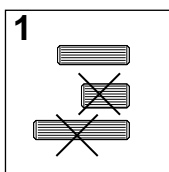

- 1: Sélectionne la taille de cheville appropriée en fonction de l'étape.
- 1: Seleccione el tamaño de espiga adecuado según el paso.

Espiga de madera

Las espigas son esenciales en el montaje de muebles para crear uniones fuertes y precisas. Garantizan la integridad estructural, evitan el desplazamiento y simplifican la alineación, lo que se traduce en muebles más resistentes y duraderos.

Sigue estos pasos:

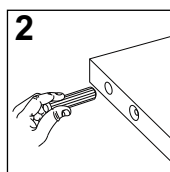

- 2: Insère dans le trou indiqué et appuie fermement pour assurer un positionnement correct.
- 2: Insértela en el orificio indicado y presione firmemente para asegurar su correcta colocación.

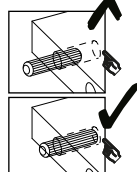

- 3: Alinee la cheville avec la pièce correspondante et enfonce-la jusqu'à ce qu'elle soit ferme.
- 3: Alinee el pasador con la pieza correspondiente y presiónelo hasta que encaje.

Étape / Paso 10



(FR)

Fixez le goujon (H) au panneau droit (1), au panneau gauche (2) et au panneau supérieur (3) à l'aide d'un tournevis cruciforme.

(ES)

Coloque el conector (H) en el panel derecho (1), el panel izquierdo (2) y el panel superior (3) usando un destornillador Phillips.

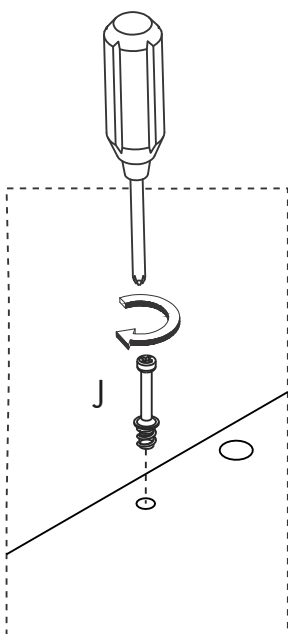
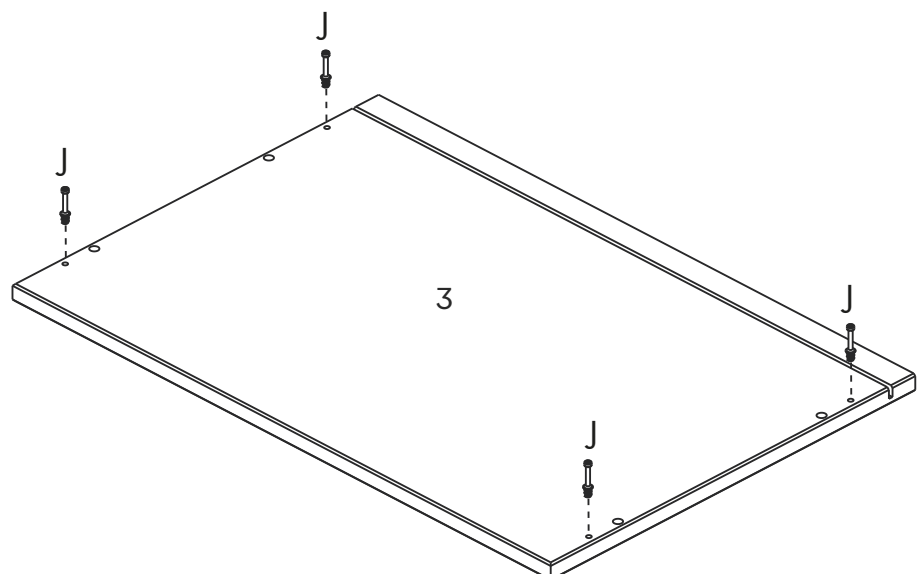
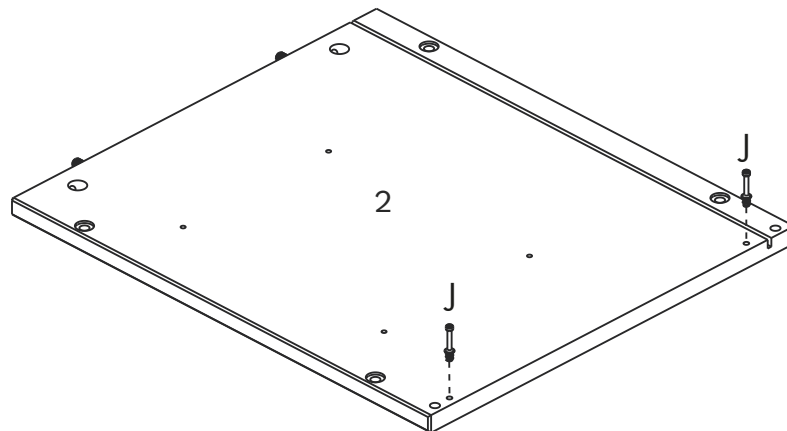
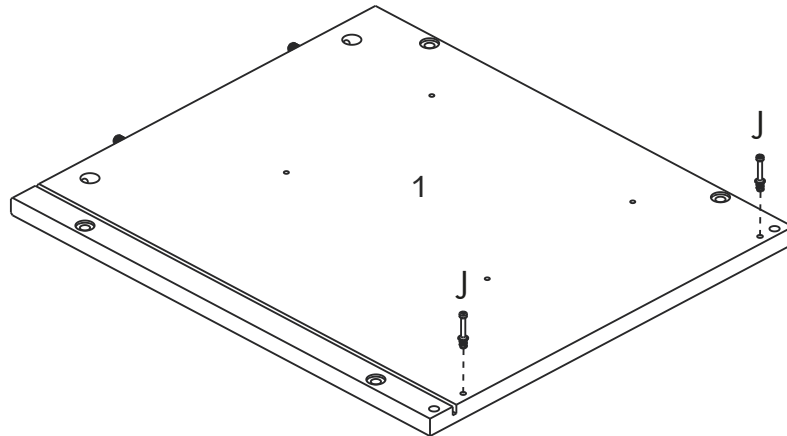

Étape / Paso 11



(FR)

Fixez le glissière extérieure (F1) au panneau droit (1) et au panneau gauche (2) à l'aide de la vis (E) et d'un tournevis cruciforme.

(ES)

Asegure el corredero exterior (F1) al panel derecho (1) y al panel izquierdo (2) usando el tornillo (E) y un destornillador Phillips.

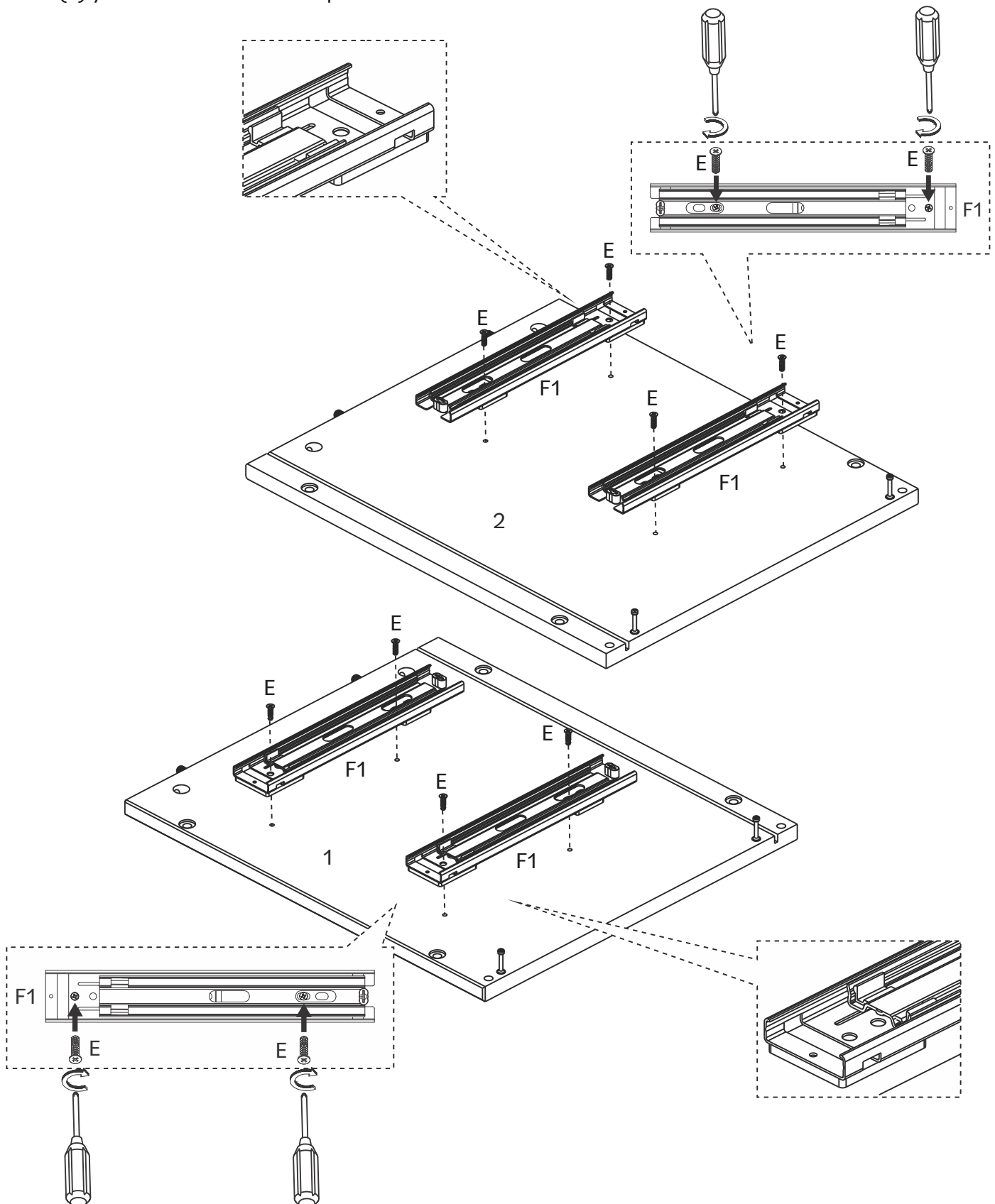

Étape / Paso 12

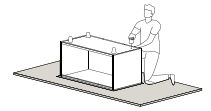

(FR)

Fixez le rail avant (4) et le barre arrière (6) au panneau gauche (1) à l'aide des boitier (I) et d'un tournevis cruciforme

(ES)

Fije el travesaño frontal (4) y el travesaño trasero (6) al panel izquierdo (1) usando traba (I) y un destornillador Phillips.

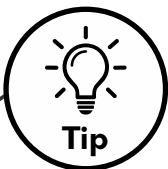
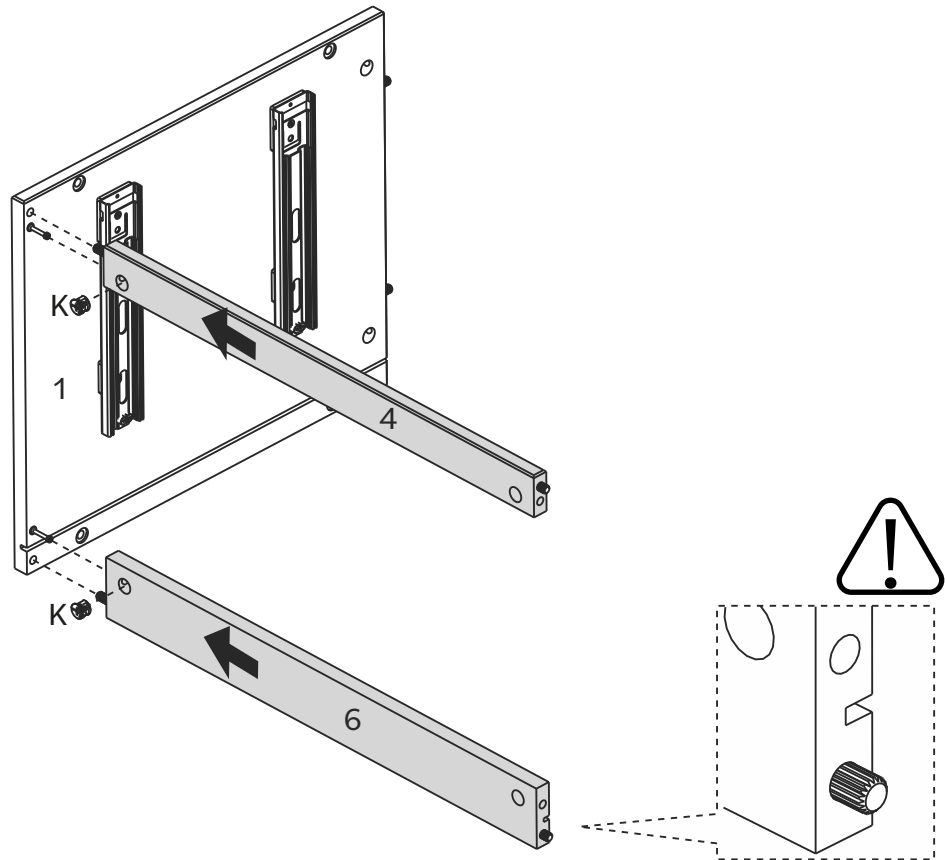

Tip

Goujon de Assemblage

Goujon de Assemblage permet de joindre deux pièces en toute sécurité. Suis ces étapes simples.

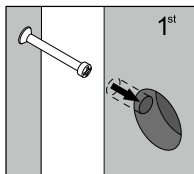

1: Insère le Goujon dans les orifices du côté plat. Ne serre pas trop!

1: Coloca el Conector en los orificios del lado plano. ¡No aprietes demasiado!

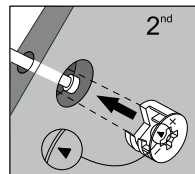

2: Joins les pièces en bois. Les Goujons entrent dans les orifices qui ont des trous sur les côtés, tu dois pouvoir voir les Goujons à travers ceux-ci. Après avoir installé les pièces, insère le Boitiers dans les orifices latéraux

2: Una las piezas de madera. Los Conectores entran en las piezas que tienen orificios en los lados, por lo que deberías poder ver los Conectores a través de ellos. Después de encajar las piezas, inserta la traba en los orificios laterales.

Conector

Los Conector ayudan a unir de forma segura dos piezas. Sigue estas fáciles etapas.

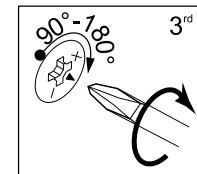

3: Sur la partie arrière du boitier, il aura la forme d'un « C ». Insère le boitier de manière à ce que l'ouverture « C » s'emboîte à la goujon. Serre-la avec le tournevis.
3: La parte posterior de la traba tendrá la forma de "C". Inserta el tambor de modo que la abertura de la "C" encaje en el Conector. Apriétalo con un destornillador.

Étape / Paso 13

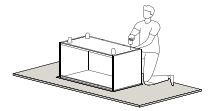

(FR)

Joindre le panneau droit (2) à l'aide des boîtiers (1) et d'un tournevis cruciforme.

(ES)

Una el panel derecho (2) usando trabas (1) y un destornillador Phillips.

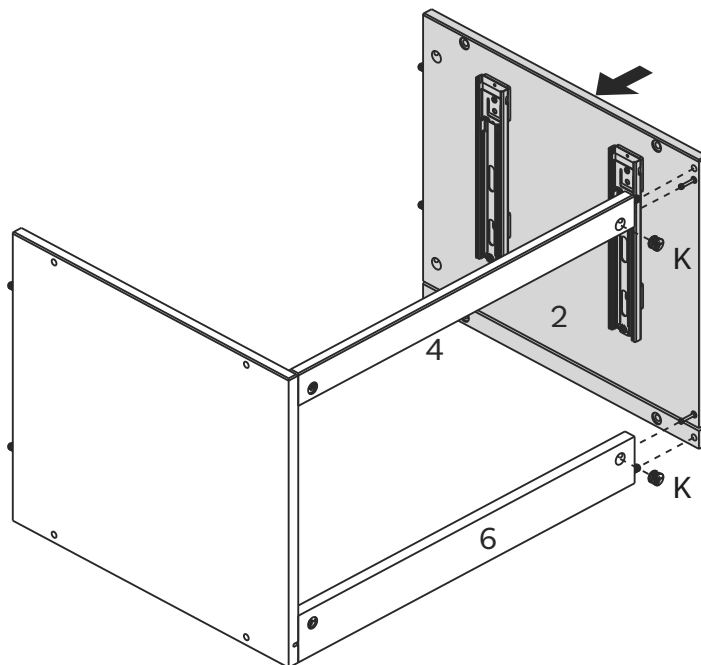
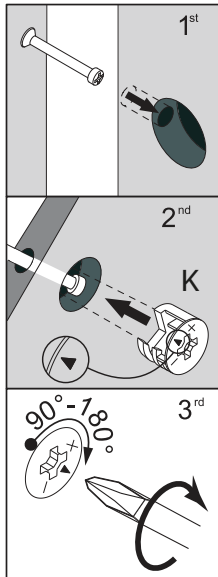

Étape / Paso 14

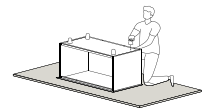

(FR) Faites glisser le panneau arrière (9) sur les rainures des panneaux gauche et droit (1 et 2) et insérez-le dans le barreau arrière (6)

(ES) Deslice el panel trasero (9) en las ranuras de los paneles izquierdo y derecho (1 y 2) y ajústelo en el travesaño trasero (6).

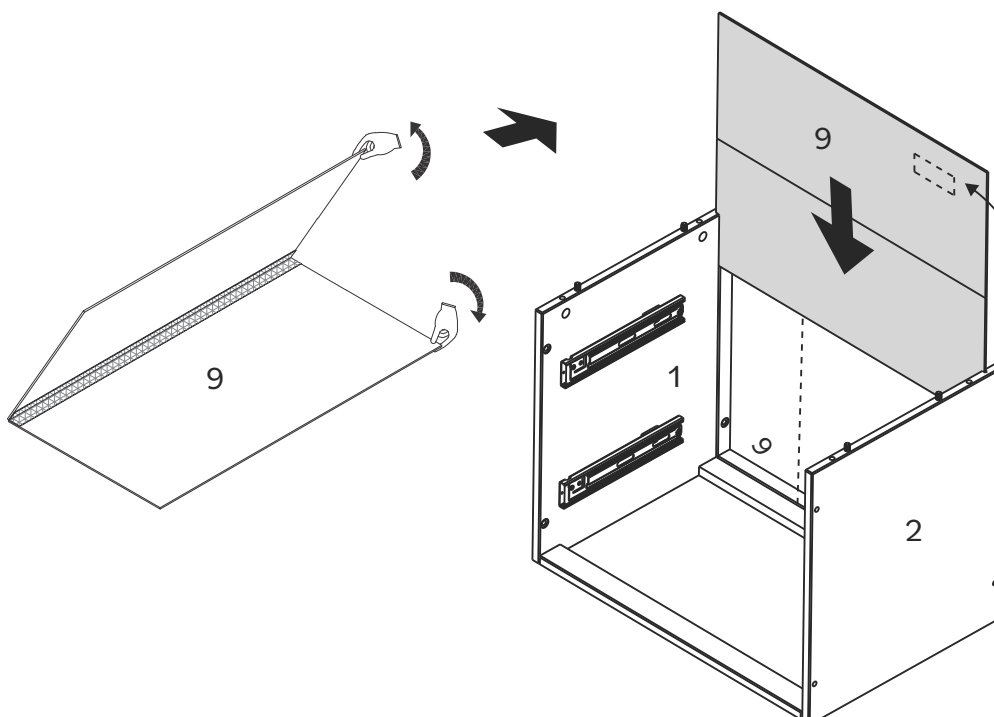

L'étiquette de traçabilité doit être orientée vers l'extérieur
La etiqueta de trazabilidad debe estar orientada hacia afuera

Nom et adresse du fournisseur et date de production.
Nombre y dirección del proveedor y fecha de producción.

Étape / Paso 15



(FR)

Fixez le panneau supérieur (3) à l'aide des boitiers (I) et d'un tournevis cruciforme.

(ES)

Asegure el panel superior (3) usando traba (I) y un destornillador Phillips

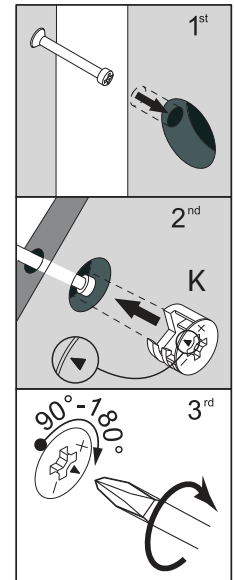
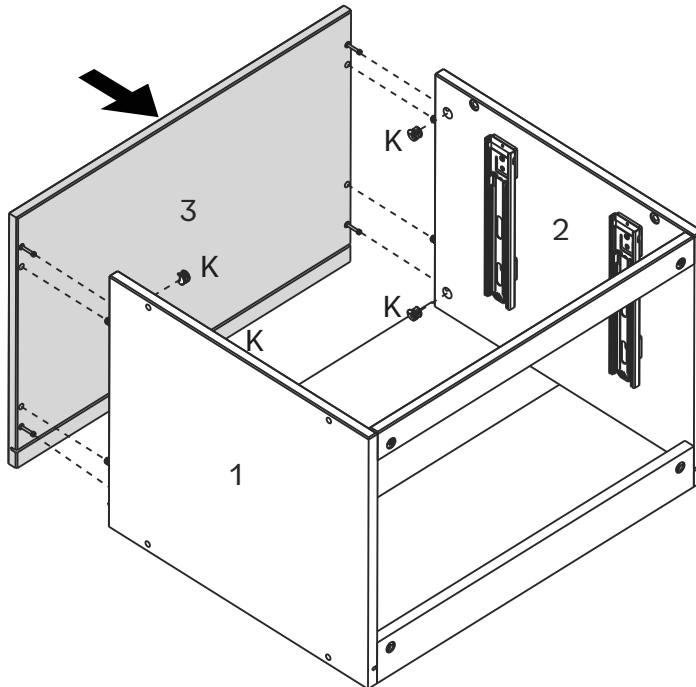

Étape / Paso 16



(FR)

Fixez le pied gauche (8) au panneau gauche (1) et le pied droit (7) au panneau droit (2) à l'aide du boulon (L) et de la clé hexagonale (M).

(ES)

Fije el pie izquierdo (8) al panel izquierdo (1) y el pie derecho (7) al panel derecho (2) usando un perno (L) y una llave hexagonal (M).

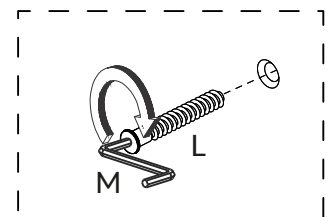
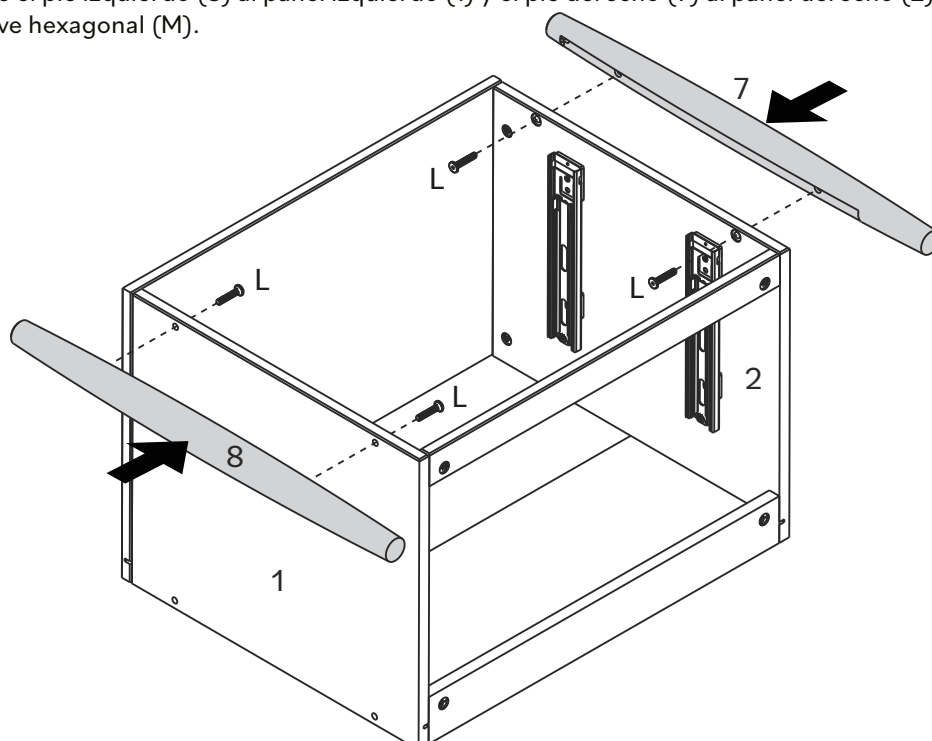

Étape / Paso 17



(FR)

À l'autre extrémité, fixez le pied gauche (8) au panneau droit (2) et le pied droit (7) au panneau gauche (1) à l'aide du boulon (L) et de la clé hexagonale (M).

(ES)

En el otro extremo, asegure el pie izquierdo (8) al panel derecho (2) y el pie derecho (7) al panel izquierdo 1 usando el perno (L) y la llave hexagonal (M).

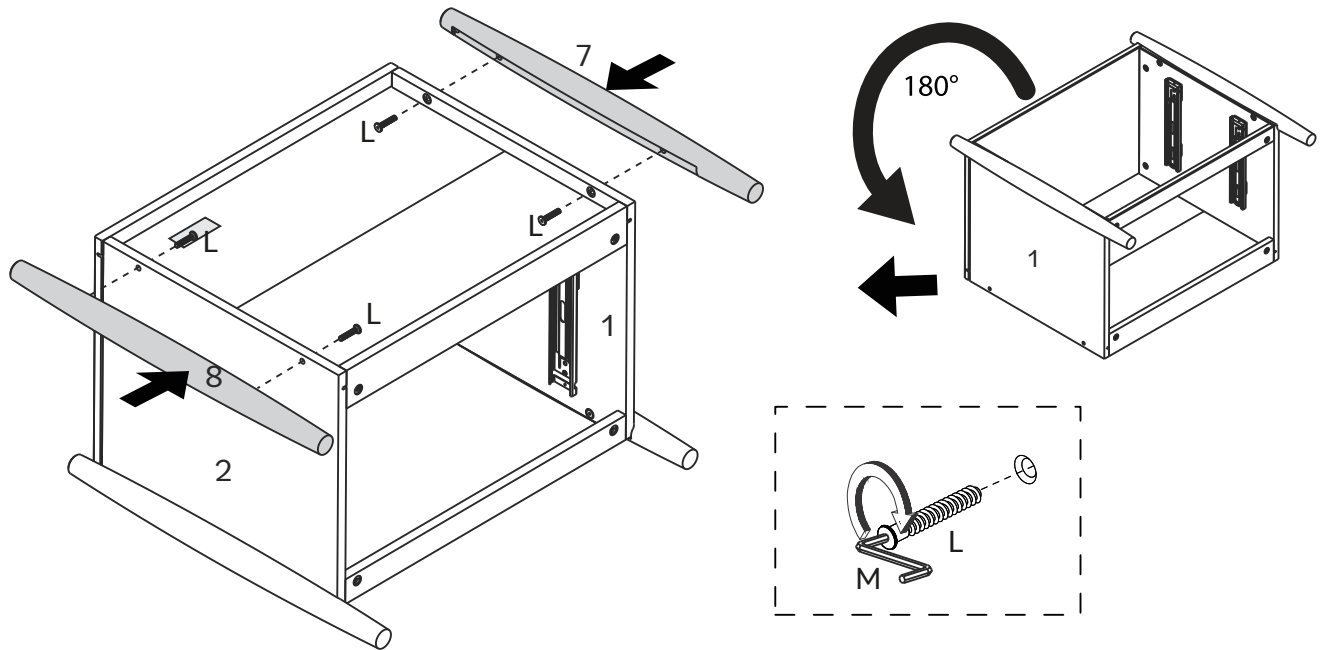

Étape / Paso 18



(FR)

Fixez le Panneau Arrière (9) en insérant la Cale (N) et la vis (O) entre le panneau et les rainures. Utilisez un tournevis Phillips.

(ES)

Asegure el Panel Trasero (9) colocando la Cuña (N) et el tornillo (O) entre el panel y las ranuras. Use un destornillador Phillips.

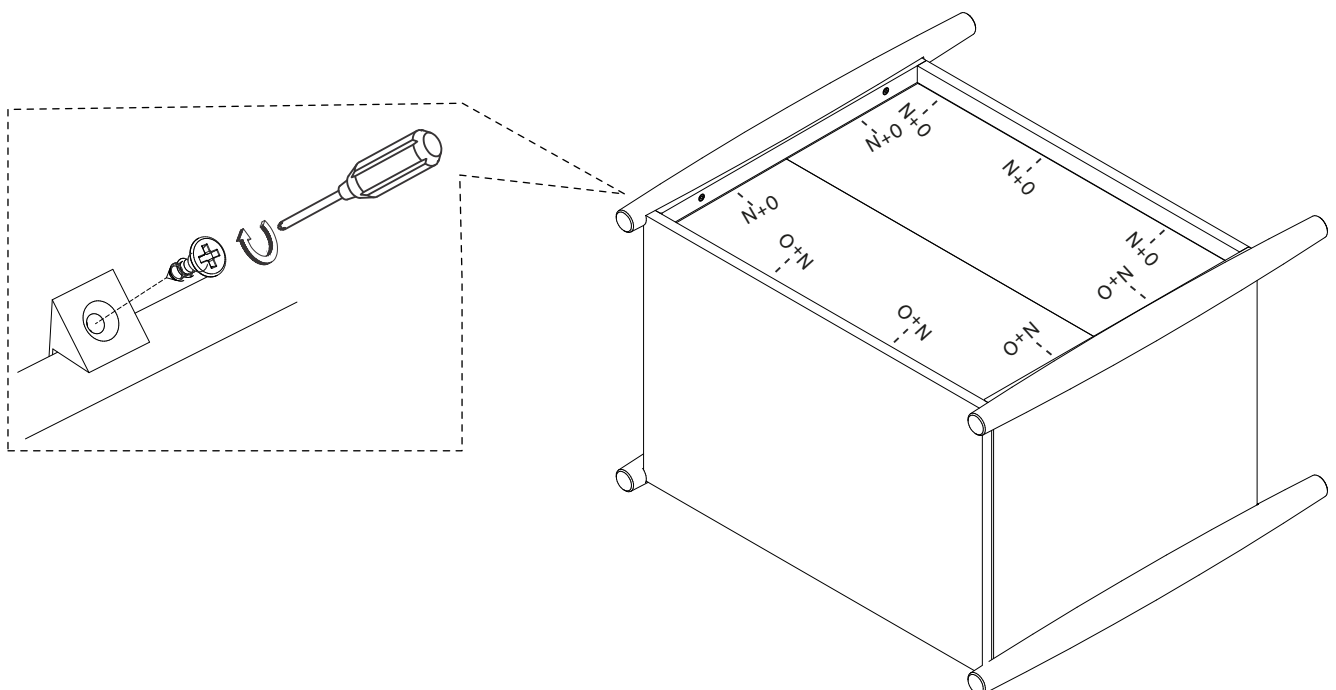

Étape / Paso 19

(FR)

Placez le tiroir à l'aide du glissière, veillez à les positionner correctement en alignant le glissière extérieur et intérieur.

(ES)

Coloque el cajón con la ayuda de la corredera, ajuste la posición correcta y alinee la corredera exterior e interior.

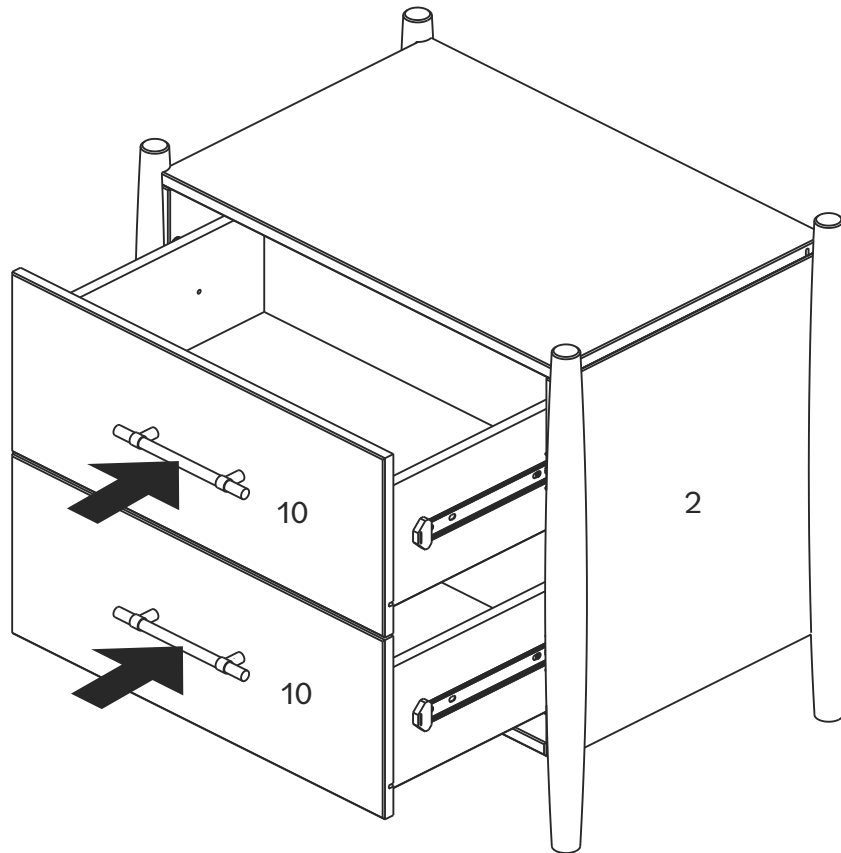

Tip

Insérez correctement le tiroir de votre armoire

Alignez les glissières extérieure et intérieure et poussez légèrement le tiroir à l'intérieur du meuble. Une fois la connexion établie, poussez le tiroir jusqu'à ce qu'il soit bien en place. Le glissement peut être délicat au début, mais il s'améliore une fois la connexion établie.

Inserte el cajón de su gabinete correctamente

Alinee las correderas exterior e interior y empuje el cajón ligeramente dentro de la unidad. Una vez que sienta la conexión, empujelo completamente hasta que encaje en su lugar. Puede que al principio no se deslice con suavidad, pero mejora una vez que esté completamente conectado..

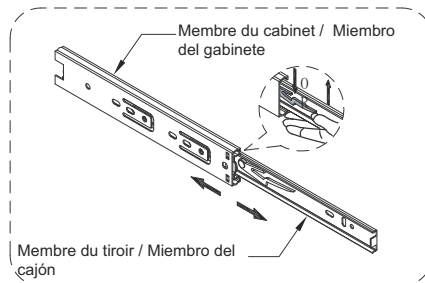

Retrait du tiroir

Il y a un levier blanc dans chaque glissière.
Pour retirer les tiroirs,
tirez le tiroir jusqu'à ce que vous voyiez le levier.
Poussez un levier vers le haut et l'autre vers le bas,
tout en poussant, tirez le tiroir vers l'extérieur.

Extracción del cajón

Hay una palanca blanca en cada riel. Para quitar los cajones,
tire del cajón hasta que vea la palanca.
Empuje una palanca hacia arriba y la otra hacia abajo,
y mientras empuja, saque el cajón.

To Disassemble / To Disassemble



(FR)

S'il est nécessaire de démonter, retirez le Dovetail Serrez (B) à l'aide d'un tournevis à tête plate.

(ES)

Si es necesario desmontarlo, retire la Traba del Dovetail (B) con un destornillador de cabeza ranurada.

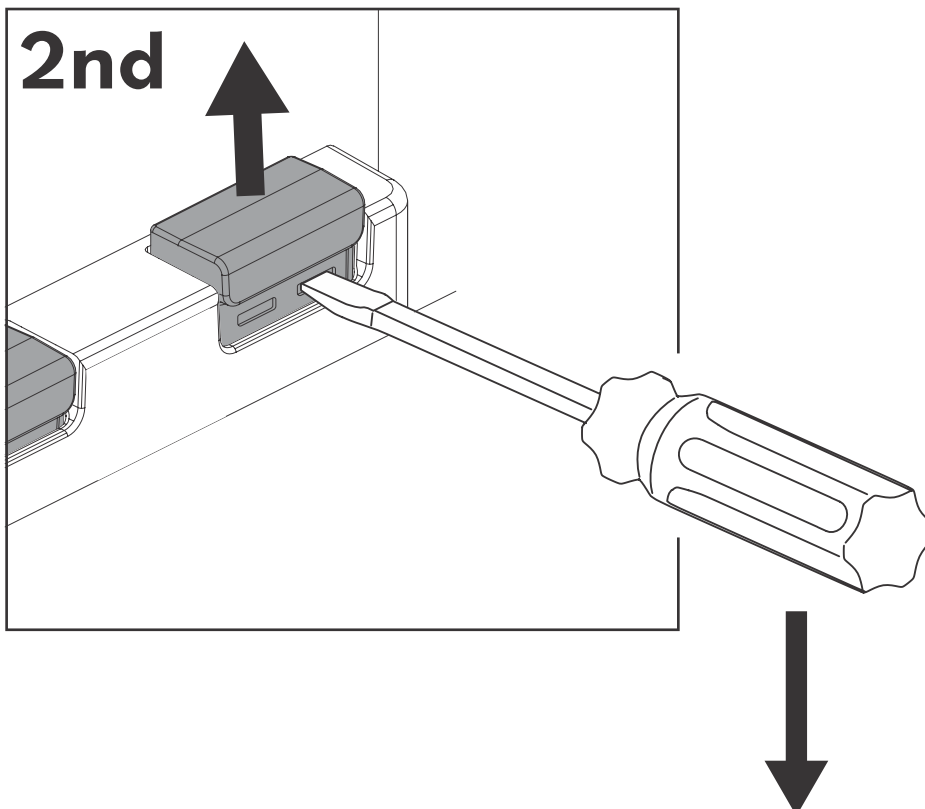
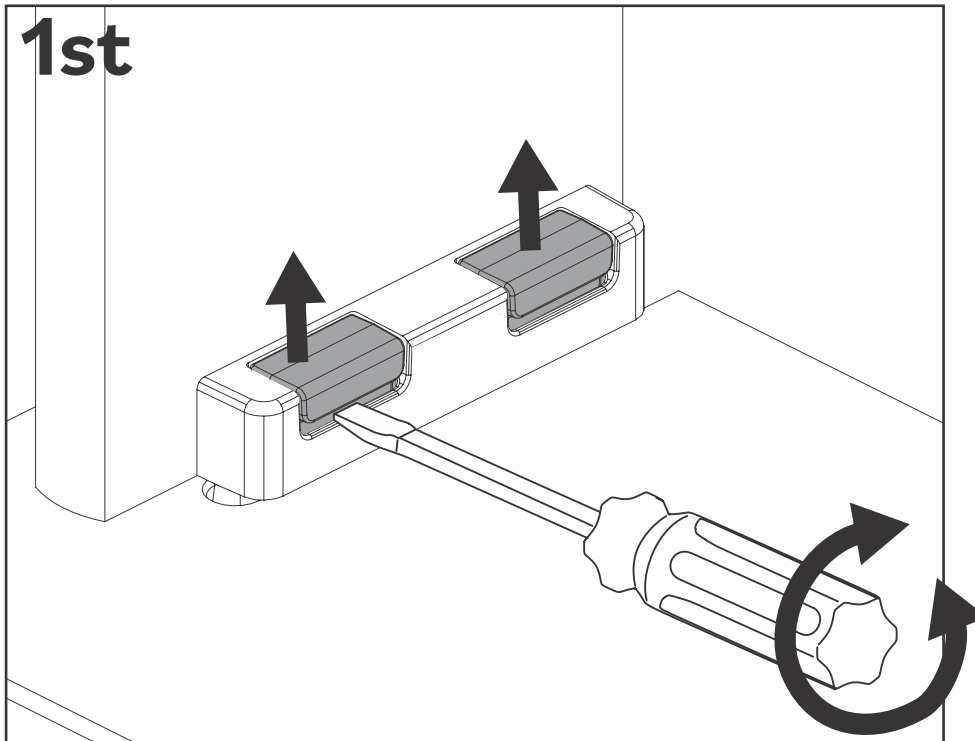

Tu as réussi ! Profite de ton nouveau table de chevet

¡Lo ha conseguido! ¡Disfrute de su nueva mesita de noche!

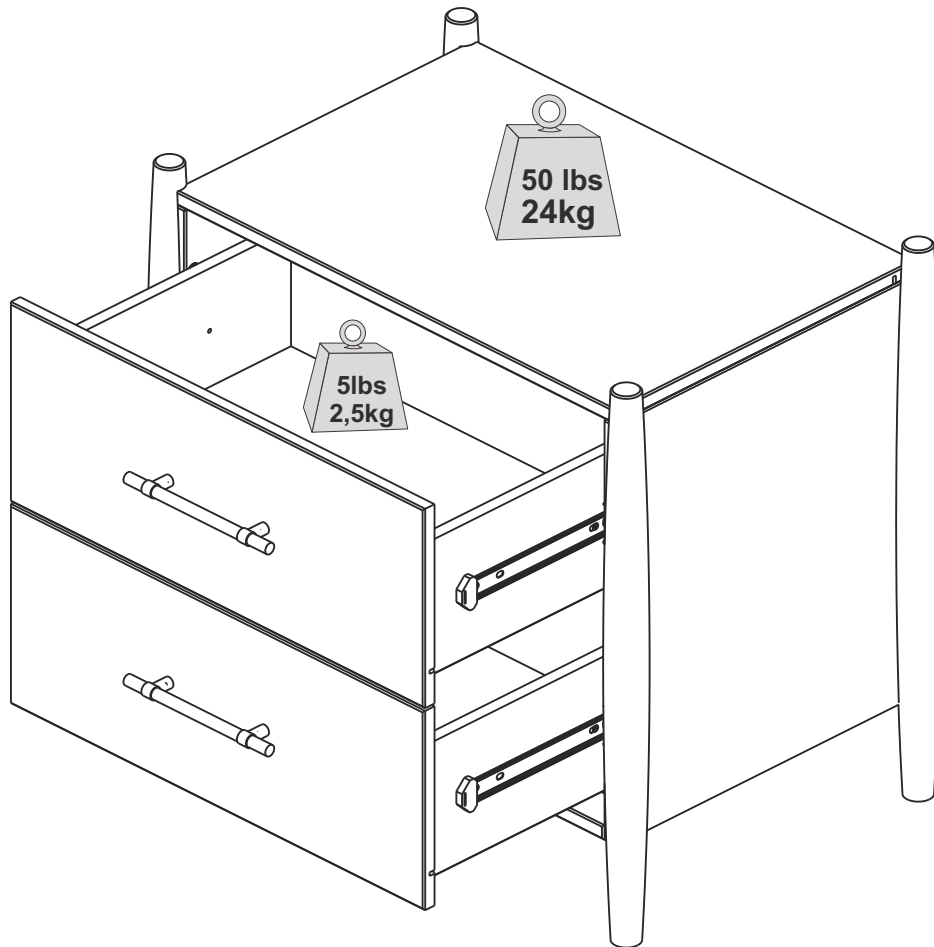

Bravo pour ton nouveau meuble !

¡Enhorabuena por sus nuevos muebles!