

ASSEMBLY INSTRUCTIONS

DINING TABLE SET



WF296667; WF296668

IMPORTANT NOTE:

- PLACE ALL PARTS ON A CLEAN AND SMOOTH SURFACE SUCH AS A RUG OR CARPET TO AVOID THE PARTS FROM BEING SCRATCHED.
- BEFORE YOU BEGIN, KINDLY FOLLOW THE ASSEMBLY INSTRUCTIONS STEP BY STEP.
- DO NOT TIGHTEN ALL SCREWS AND BOLTS UNTIL THE TABLE SET IS FULLY SET-UP.

CARTON CONTENT:

WF296668 :

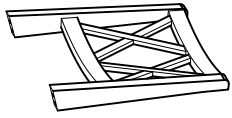

1 x 4

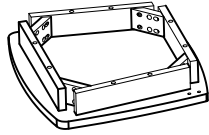

2 x 4



3 x 8

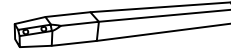

4 x 8



5 x 1

WF296667 :

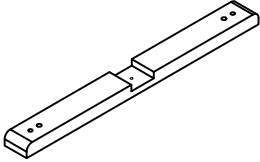

1 x 1

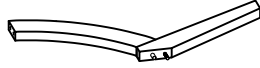

2 x 4

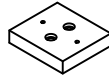

3 x 4

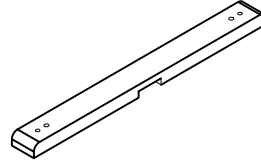

4 x 1



6 x 4

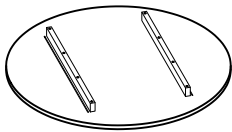

7 x 1

TABLE PART LISTS

NO.	DESCRIPTION	SKETCH	QTY
1	TABLE LEG (L) TOP SUPPORT		1 PC
2	TABLE LEG		4 PCS
3	TABLE LEG SUPPORT		4 PCS
4	TABLE LEG (R) TOP SUPPORT		1 PC
5	PEDESTAL		1 PC
6	TABLE LEG BOTTOM SUPPORT		4 PCS
7	TABLE TOP		1 PC

TABLE HARDWARE LISTS

NO.	DESCRIPTION	SKETCH	QTY
A	HEX NUT 5/16"		4 PCS
B	SPRING WASHER 5/16"		4 PCS
C	FLAT WASHER 5/16"		4 PCS
D	SPANNER 12.8		1 PC
E	JCBC BOLT M6 x 45mm		16 PCS
F	JCBC BOLT M6 x 50mm		4 PCS
G	FLAT WASHER 1/4"		4 PCS
H	SPRING WASHER 1/4"		20 PCS
I	ALLEN KEY M4		1 PC
J	WOOD DOWEL M8 x 30mm		4 PCS
K	C/B SCREW M4 x 20mm		1 PC
L	C/B SCREW M4 x 30mm		8 PCS

STEP 1

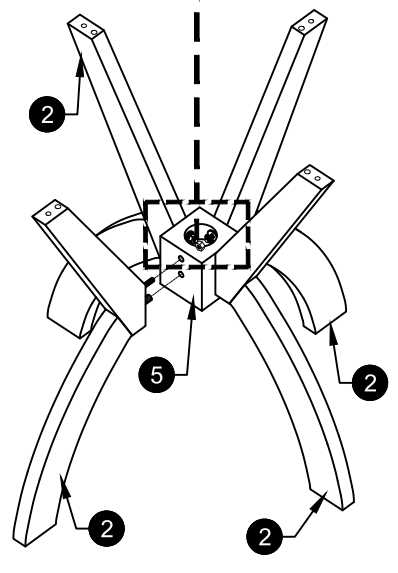
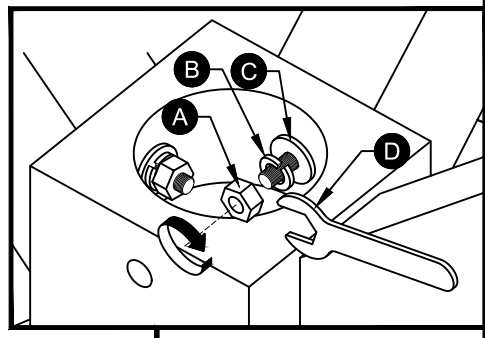

STEP 2

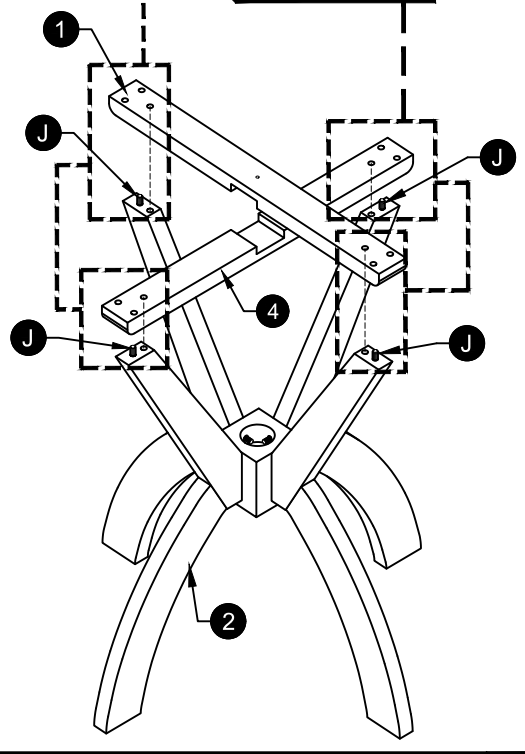
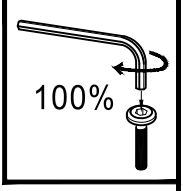
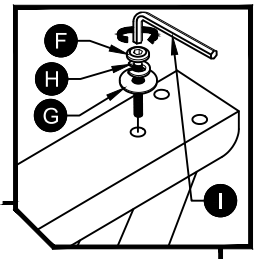

STEP 3

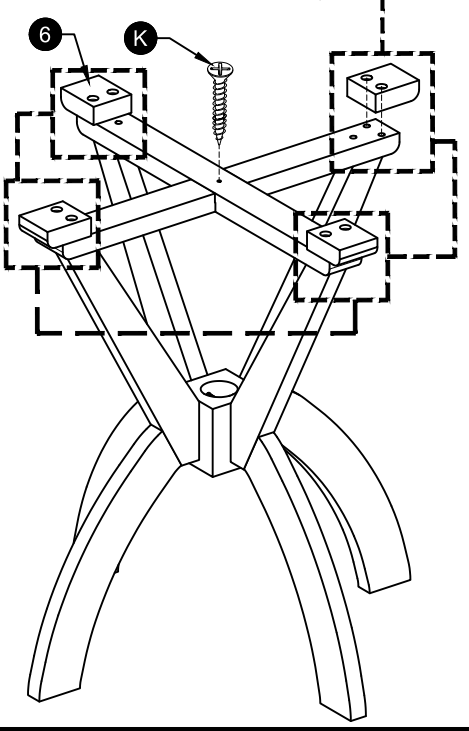
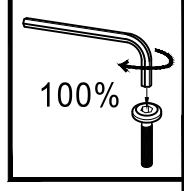
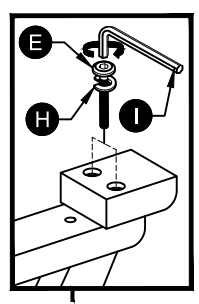

STEP 4

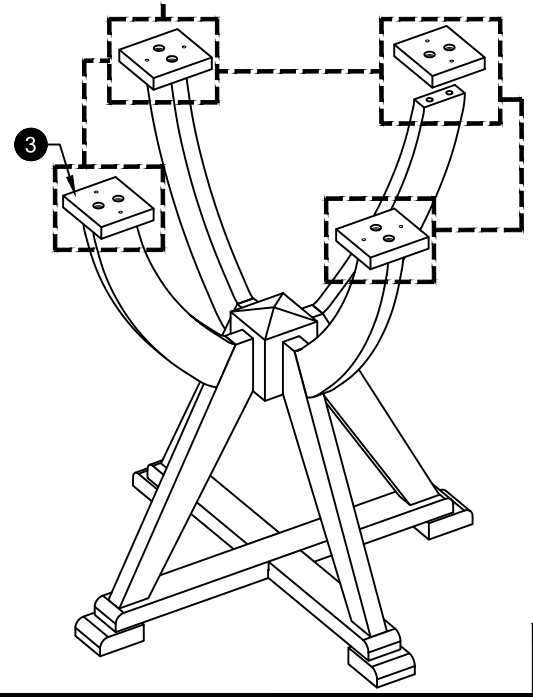
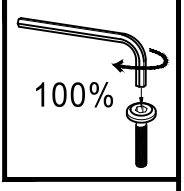
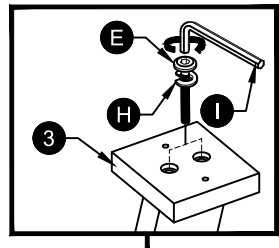

STEP 5

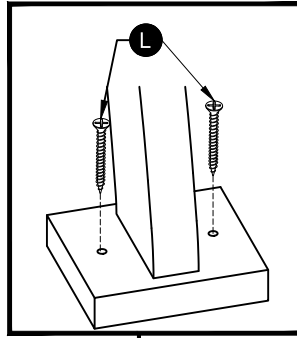
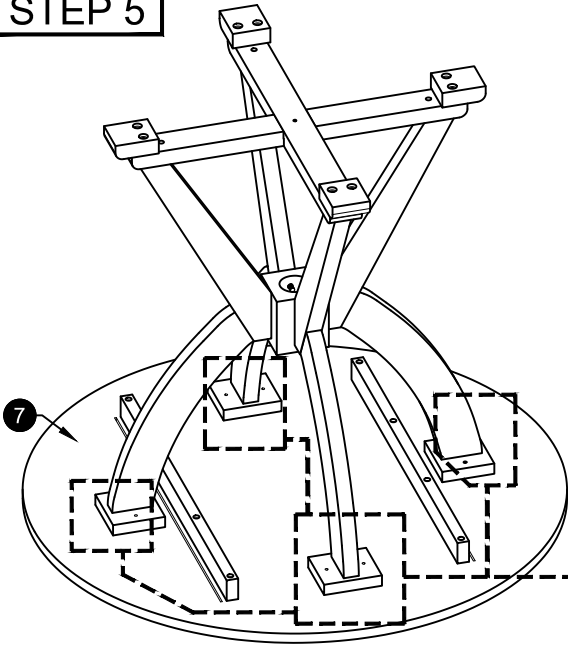

ASSEMBLY COMPLETE !



CHAIR PART LISTS

NO.	DESCRIPTION	SKETCH	QTY
1	BACK REST		4 PCS
2	SEAT		4 PCS
3	FRONT LEG		8 PCS
4	BACK LEG		8 PCS

CHAIR HARDWARE LISTS

NO.	DESCRIPTION	SKETCH	QTY
A	JCBC BOLT M6 x 50mm		16PCS
B	JCBC BOLT M6 x 60mm		32 PCS
C	SPRING WASHER 1/4"		48 PCS
D	FLAT WASHER 1/4"		32 PCS
E	ALLEN KEY M4		1 PC

STEP 6

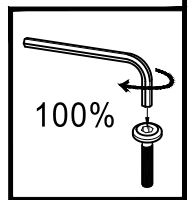
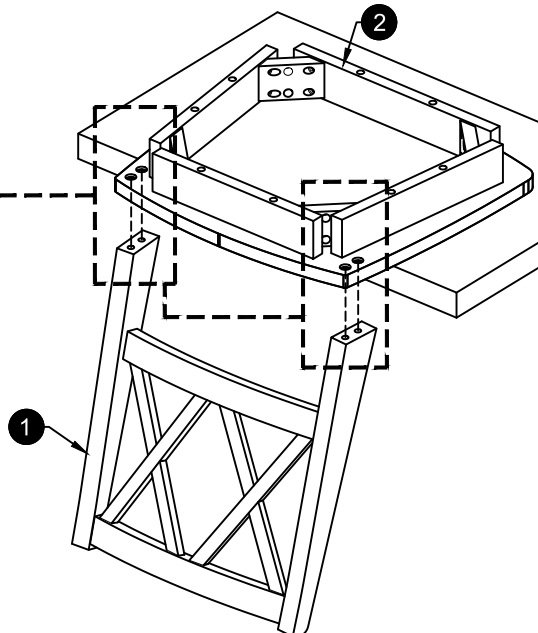
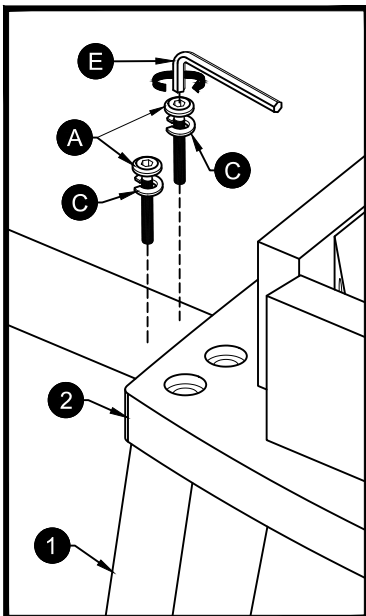

STEP 7

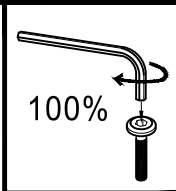
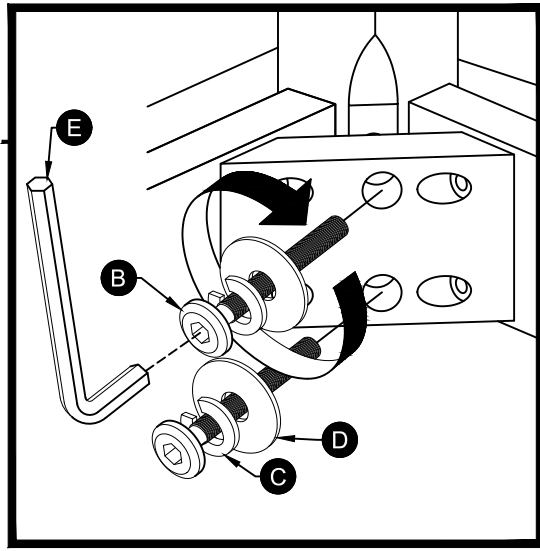
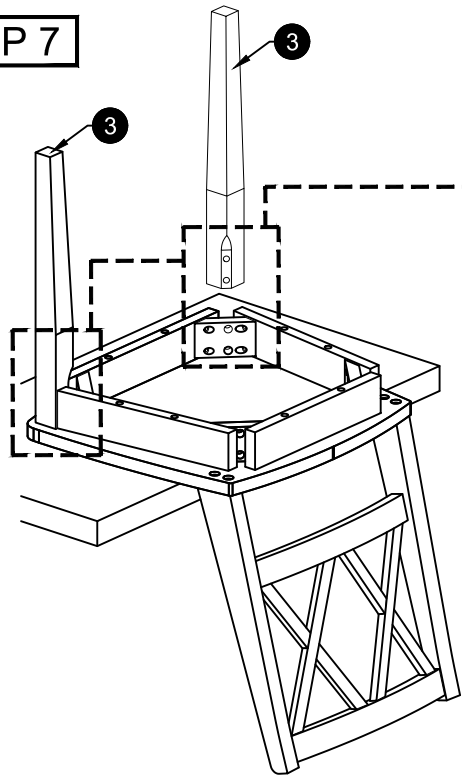

STEP 8

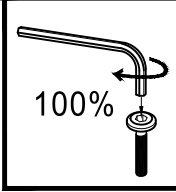
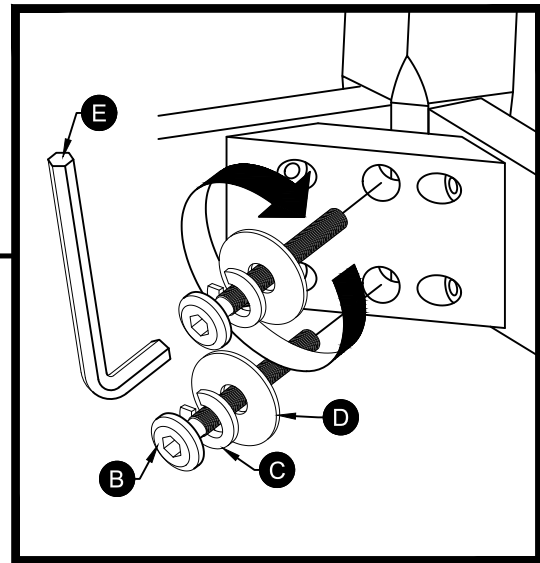
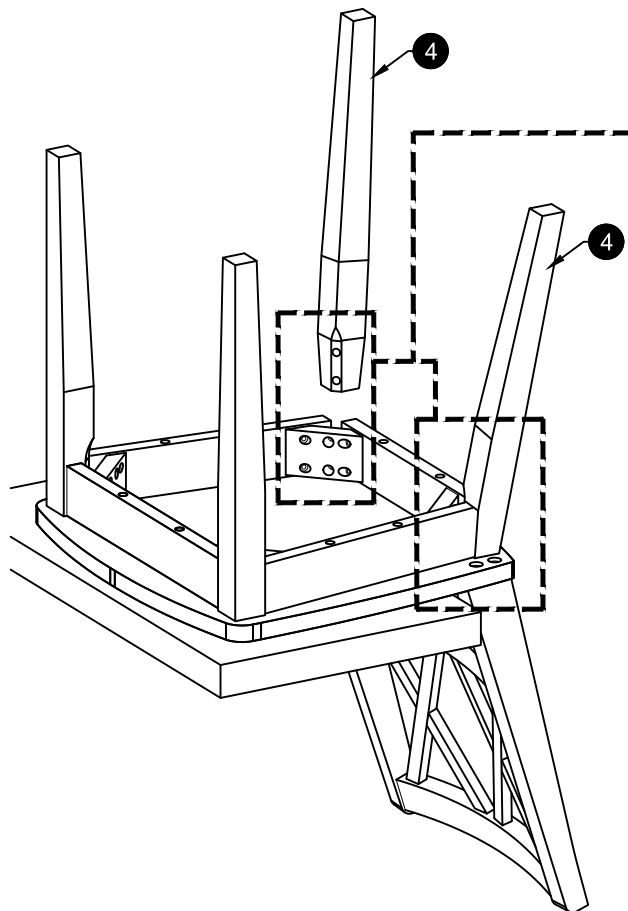

ASSEMBLY COMPLETE !

