



We strive to ensure that our products are of the highest quality and free of manufacturing defects or missing parts. However, if you have any problems with your new product,

DO NOT RETURN IT TO THE STORE,

please contact us toll free @:

1-888-996-2729

FAX: 1-866-873-3531

gameroom@escaladesports.com

Or write to:

Escalade Sports

Customer Service Department

P.O. Box 889

Evansville, IN 47706

Please visit our Web site at:

www.escaladesports.com

Please have your date code when inquiring about parts.

When contacting Escalade Sports please provide your model number, date code (if applicable), and part number if requesting a replacement part. These numbers are located on the product, packaging, and in this owners manual.

Your Model Number **45-6800W/F**

Date Code: **2 - 45-6800W/F - - HL**

Purchase Date: _____

PLEASE RETAIN THIS INSTRUCTION MANUAL FOR FUTURE REFERENCE

**IMPORTANT! READ EACH STEP
IN THIS MANUAL BEFORE YOU
BEGIN THE ASSEMBLY.**

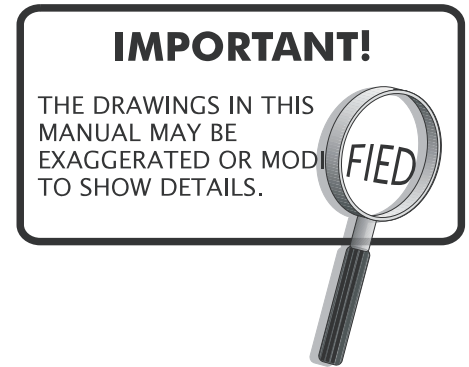

TWO ADULTS ARE REQUIRED TO ASSEMBLE THIS 72” LUMEN-X LAZER AIR HOCKEY TABLE

Tools Required:

- T1 - Allen Wrench (Included)
- Phillips Screwdriver
- Furniture Polish and Cloth

An electric screwdriver is helpful in assembly. However, please set at low torque and use extreme caution with an electric screwdriver because you could overtighten the hardware and strip the screws.

Assembly Tips

Make sure you understand the following tips before you begin to assemble your hockey table.

1. Start all bolts by hand before tightening.
2. Some drawings or images in this manual may not look exactly like your product. Please read and understand the text before starting each assembly step.

This device complies with Part 15 of the FCC Rules. Operation is subject to the following two conditions:

- (1) this device may not cause harmful interference, and
- (2) this device must accept any interference received, including interference that may cause undesired operation.

ATTENTION:

**READ AND FOLLOW ALL ASSEMBLY, OPERATION, AND
SAFETY INSTRUCTIONS CAREFULLY. AT LEAST TWO
ADULTS ARE NEEDED TO PUT THIS HOCKEY TABLE
TOGETHER.**

IMPORTANT SAFETY INSTRUCTIONS

READ ALL INSTRUCTIONS

1. Read all instructions-All the safety and operating instructions should be read carefully before the hockey game is played.
2. **Caution**-This is not a toy and is intended for use by or under the supervision of adults. Adults should review safety guidelines with children to avoid possible risk of electric shock or other injuries.
3. **Power sources**-This hockey game should be operated only from 110-120V A.C., 60 cycle current as indicated on the identification label. If you are not sure of the type of power supply to your home, consult your appliance dealer or local power company.
4. **Power cord protection**-Power cord should be routed so that it is not likely to be walked on or pinched by items placed upon or against it. Pay particular attention to cords at plugs, convenience receptacles, and the point of exit from the game.
5. **Overloading**-Do not overload wall outlets and extension cords as this can result in a risk of fire or electric shock.
6. **Object and liquid entry**-Never push objects of any kind into this game through openings as they may touch dangerous voltage points or short-out parts which could result in a fire or electric shock. Never spill liquid of any kind on the game.
7. **Ventilation**-Openings in the game are provided for the exhaust air to create a cushion effect. The openings on the air blower are for the intake air. Keep clear of the air blower when it is on. Do not put hand or other objects near the intake openings. To ensure reliable operation of the game and protect it from overheating these openings must not be blocked or covered.
8. **Damage requiring service**-Unplug the game from the wall outlet. Do not attempt to service the blower yourself as opening or removing covers may expose you to dangerous voltage or other hazards. Refer servicing to qualified service personnel under the following conditions.
 - A. When the power supply cord or plug is damaged.
 - B. If liquid has spilled, or objects have fallen into the blower.
 - C. When the air blower exhibits a distinct change in performance e.g. abnormal noise, this indicates a need for service.
9. **CAUTION-ELECTRICALLY OPERATED PRODUCT**-Not recommended for children under 8 years of age. As with all electrical products, precautions should be observed during handling and use to reduce the risk of electric shock.
10. We recommend that the game be periodically examined for conditions that may result in the risk of fire, electrical shock, or injury to persons. In the event such conditions exist, the game should not be used until properly repaired.
11. **RISK OF FIRE, ELECTRIC SHOCK, OR INJURY TO PERSONS**

WARNING-When using electric appliances, basic precautions should always be followed, including the following:

 - A) Read all the instructions before using the appliances.
 - B) To reduce the risk of injury, close supervision is necessary when an appliance is used near children.
 - C) Do not contact moving parts.
 - D) Only use attachment recommended or sold by the manufacturer.
 - E) Do not use outdoors.
 - F) For a cord-connected appliance, the following shall be included:
 - To disconnect, turn all controls to the off position, then remove plug from outlet.
 - Do not unplug by pulling on cord. To unplug, grasp the plug, not the cord.
 - Unplug from outlet when not in use and before servicing or cleaning.
 - Do not operate any appliance with a damaged cord or plug, or after the appliance malfunctions or is dropped or damaged in any manner. Return appliance to the nearest authorized service facility for examination, repair, or electrical or mechanical adjustment.

SAVE THESE INSTRUCTIONS

WARNING: To Reduce The Risk Of Fire Or Electric Shock, Do Not Use This Fan With Any Solid-State Speed Control Device.

For Household use only.

HARDWARE IDENTIFIER (To Scale)

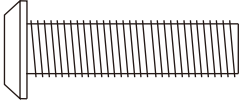

H1 - 8 mm x 28 mm
Allen Head Bolt
(12 pcs)

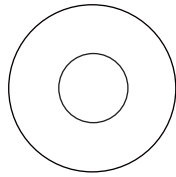

H2 - 8.5 mm x 22 mm
Flat Washer
(12 pcs)

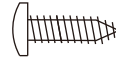

H3 - 3.5 mm x 12 mm
Phillips Round
Head Screw
(24 pcs)



H4 - 3.5 mm x 28 mm
Phillips Round
Head Screw
(2 pcs)

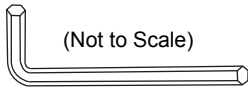

(Not to Scale)

T1 - Allen Wrench
(1 pc)

ACCESSORIES IDENTIFIER (Not to Scale)

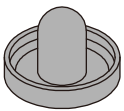

A1 - **BLUE**
LED Striker
(2 pcs)



A2 - Clear with
BLUE LED Puck
(1 pc)



A3 - Red Puck
(2 pcs)



A4 - Felt Pad
(2 pcs)

NOTE:
A4 Felt Pads may already
be attached to A1 Strikers.

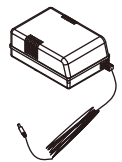

A5 - A/C
Adapter
(1 pc)

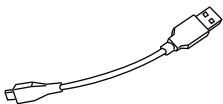

A6 - USB Cable
(Only used to charge the A1 LED Strikers)
(1 pc)



PARTS IDENTIFIER

(Not to Scale)

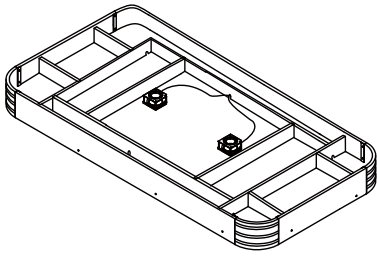

P1 - Air Hockey Cabinet
(1 pc)



P2 - Right Leg
(2 pcs)

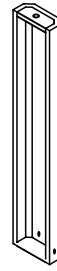

P3 - Left Leg
(2 pcs)

(Packed
under table)

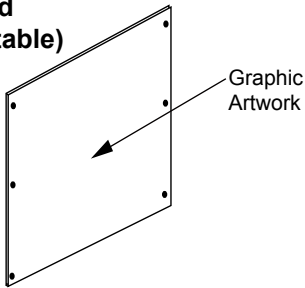

P4 - End Leg Panel
with Graphic Artwork
(Packed underneath Table)
(2 pcs)

(Packed
under table)

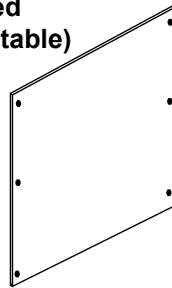

P5 - End Leg Panel
without Graphic Artwork
(Packed underneath Table)
(2 pcs)



P6 - Leg Leveler
(4 pcs)

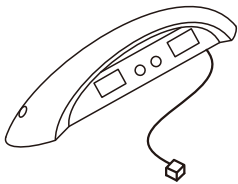

P7 - Electronic Scorer
(1 pc)



PARTS REQUIRED:

- | | |
|-------------------------------------|-------------------------------|
| 12 pcs - H1 Allen Head Bolt | 2 pcs - P2 Right Leg |
| 12 pcs - H2 Flat Washer | 2 pcs - P3 Left Leg |
| 1 pc - P1 Air Hockey Cabinet | 1 pc - T1 Allen Wrench |

STEP 1:

Leave **P1** Air Hockey Table Cabinet face down in carton to assemble.

Install **P2** Right Legs and **P3** Left Legs onto **P1** Air Hockey Cabinet using **H1** Allen Head Bolts and **H2** Flat Washers as shown in **FIGURE 1**. Use Allen Wrench **T1** to tighten Bolts.

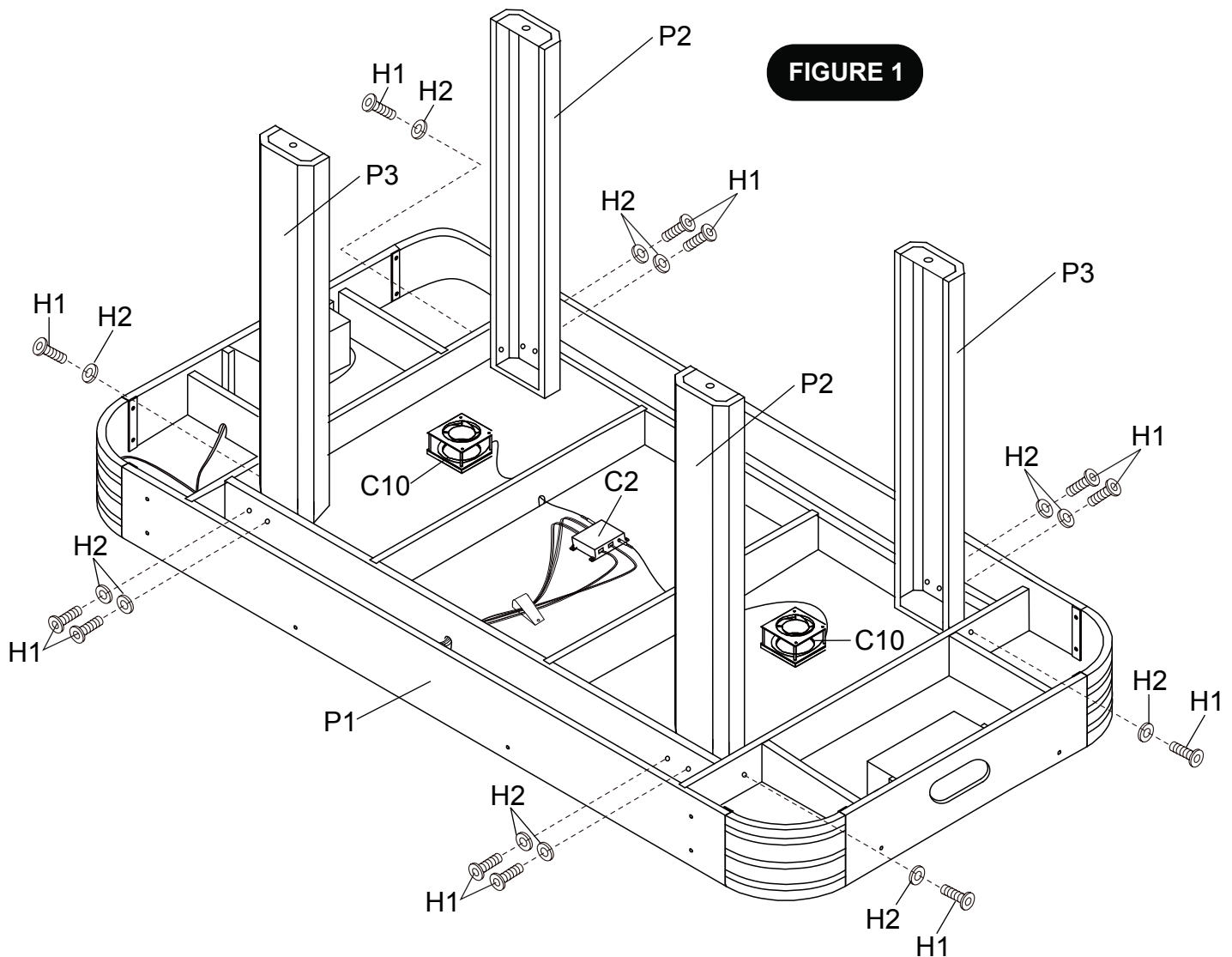

PARTS REQUIRED:

- 24 pcs - **H3** Phillips Round Head Screw
- 2 pcs - **P4** End Leg Panel with Graphic Artwork
- 2 pcs - **P5** End Leg Panel without Graphic Artwork
- 4 pcs - **P6** Leg Leveler

STEP 2:

Install **P4** End Leg Panels with Graphic Artwork and **P5** End Leg Panels without Graphic Artwork to Legs using **H3** Phillips Round Head Screws as shown in **FIGURE 2**.

Tighten, but do not strip out H3 Screws.

Thread **P6** Leg Levelers to Legs as shown in **FIGURE 2**.

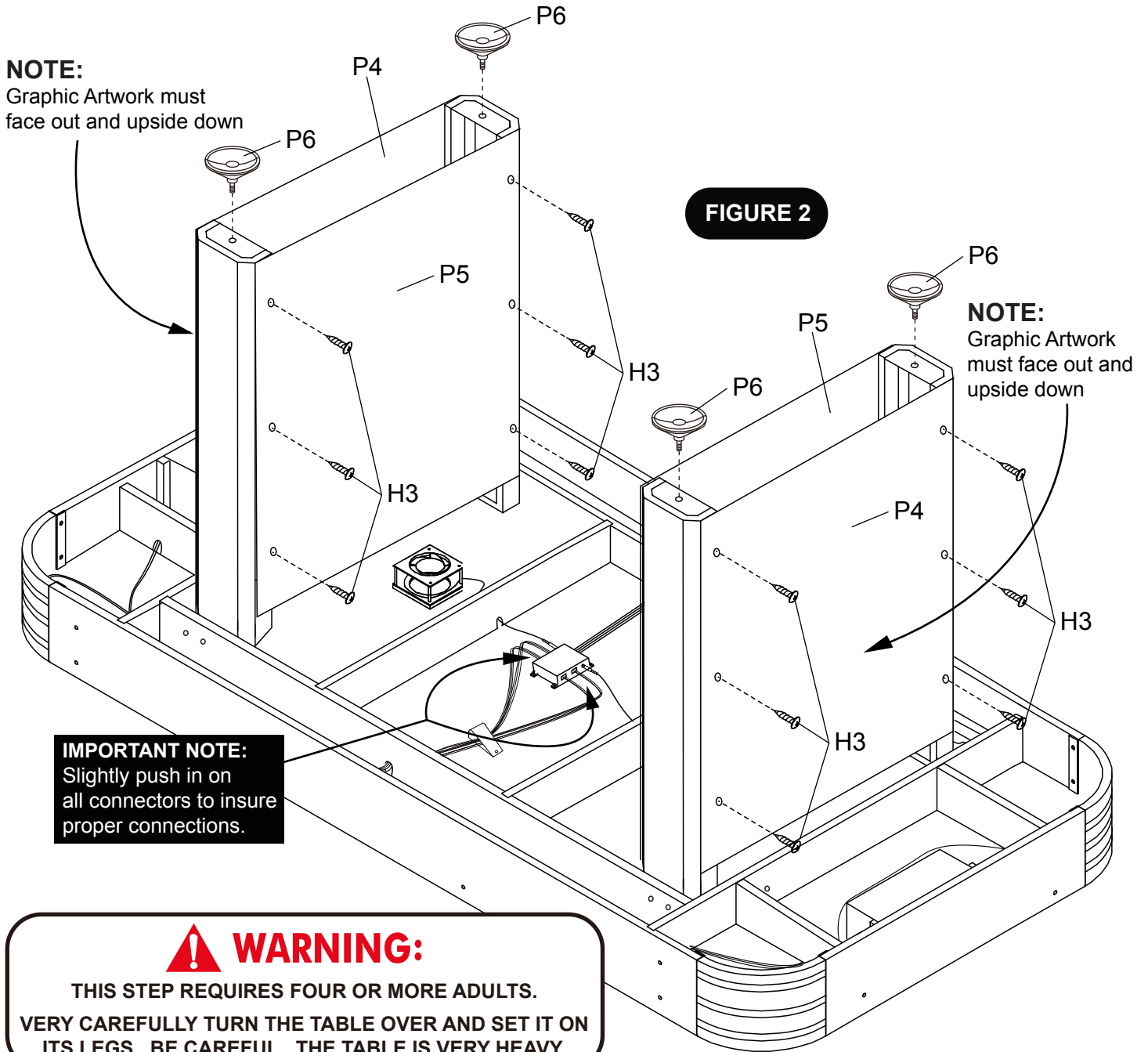

PARTS REQUIRED:

- 2 pcs - **H4** Phillips Round Head Screw
- 1 pc - **P7** Electronic Scorer
- 1 pc - **A5** A/C Adapter

STEP 3:

First, feed the **P7** Electronic Scorer plug through hole on one side of the long top apron as shown in **FIGURE 3**.

Next, feed the plug through underneath support beams and connect to Main Electronic Unit **C2** as shown in **FIGURE 3** and **DETAIL A**.

IMPORTANT NOTE: This connector will only fit into the C2 Main Electronic Unit if it is turned correctly. It has two small plastic male tabs on the outside that must fit correctly into it's female counterpart socket on the C2 Main Electronic Unit. **DO NOT FORCE THIS CONNECTION** and a flashlight will be very helpful to study both the male plug and female socket to insure a correct connection.

Next, install **P7** Electronic Scorer onto long top apron using pilot holes with **H4** Screws as shown in **FIGURE 3**. Tighten, but do not strip out **H4** Screws.

Connect **A5** A/C Adapter onto Main Electronic Unit **C2** (underneath table).

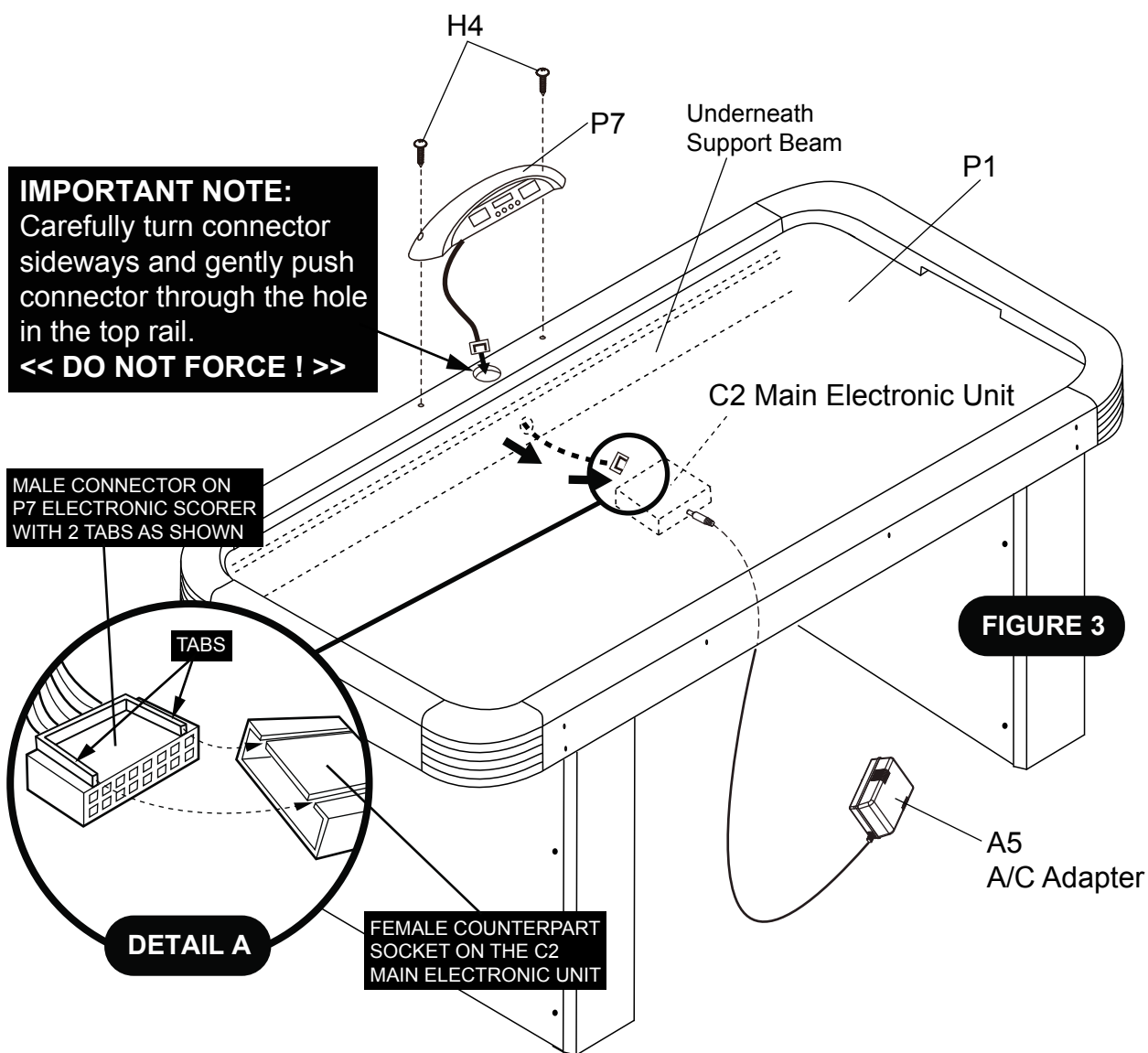

LED PUCK BATTERY CHANGE INSTRUCTION

STEP ONE:

Remove screws and back cap from LED Puck using **Small Phillips Screwdriver** (not provided).

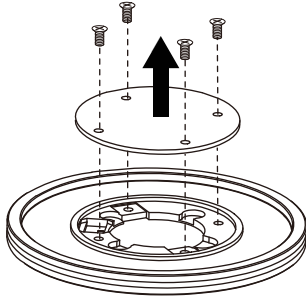

STEP TWO:

Remove CR2016 Lithium Battery 3V from LED Puck.

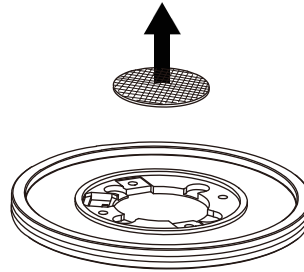

IF BATTERY HOLDER BRACKET MOVES, RE-INSTALL IT TO LED PUCK AS SHOWN IN DIAGRAM.

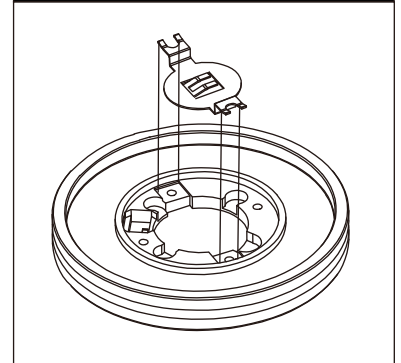

STEP THREE:

Insert new CR2016 Lithium Battery 3V into LED Puck.

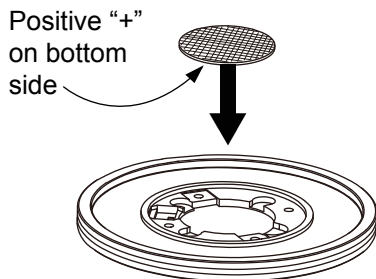

STEP FOUR:

Install back cap and secure screws with Phillips Screwdriver (not provided).

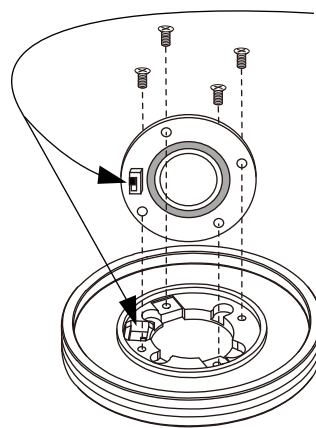

NOTE:

Make sure the on/off switch on the back cap properly aligns and fits into its slot in the LED puck during reassembly

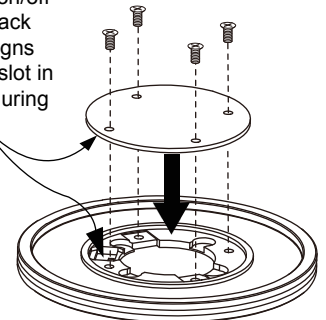

Helpful Hint:

The LED puck battery will last approximately 7 hours of continuous play. The puck battery is not rechargeable. Be sure to turn the switch to the "OFF" position when **not in use to conserve your battery life.**

LED STRIKER BATTERY CHARGE INSTRUCTION

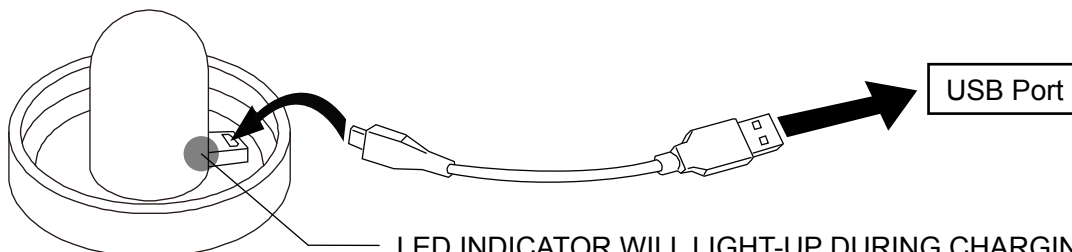

LED INDICATOR WILL LIGHT-UP DURING CHARGING AND WILL TURN OFF WHEN ITS FULLY CHARGED.

Helpful Hint:

The LED strikers each will require about 4 hours to fully charge up and will last approximately 7 hours of continuous play time. Be sure to turn the switch to the "OFF" position when not in use.

Replacement of LED Light Rail

STEP ONE :

If the LED Light Rail needed to be replaced on the **P7** Electronic Scorer side, Carefully unplug the connector of **P7** Electronic Scorer from the **C2** Main Electronic Unit first.

Unscrew **C9** wing Bolts and then unplug the **C5** Lighting LED Rail A.

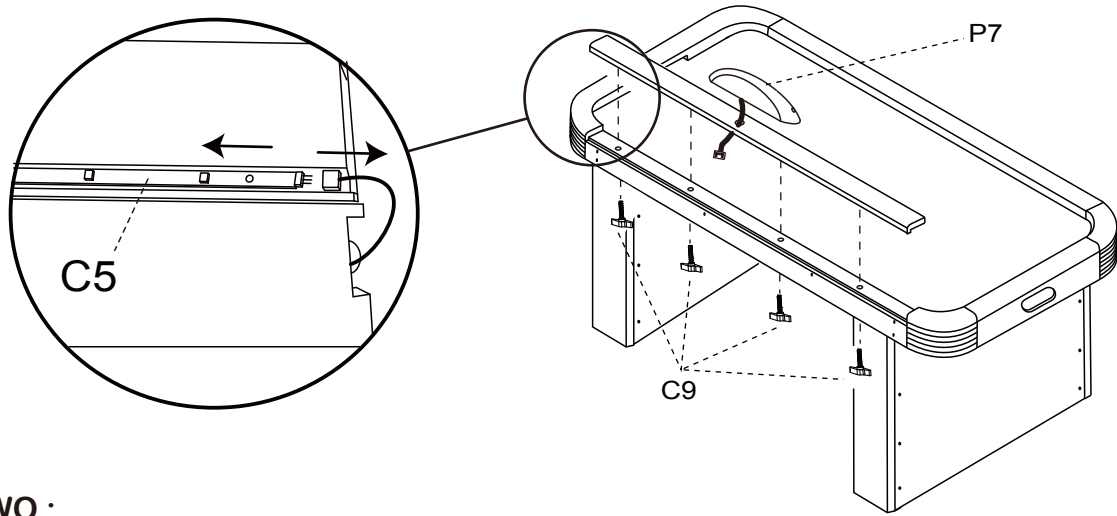

STEP TWO :

unscrew **C8** Screws, and separate **C5** Lighting LED Rail A, **C6** Lighting LED Rail B and **C7** Lighting LED Rail C from each other.

Align the male and female connectors of the well Lighting LED Rail, and Install them back to Side Top Rail using **C8** Screws as shown in the diagram.

Next, connect the plug of **C5** Lighting LED Rail A.

Install the Side Top Rail back to the table top rail using **C9** Wing Bolts .

Tighten, but do not strip out C8 screws .

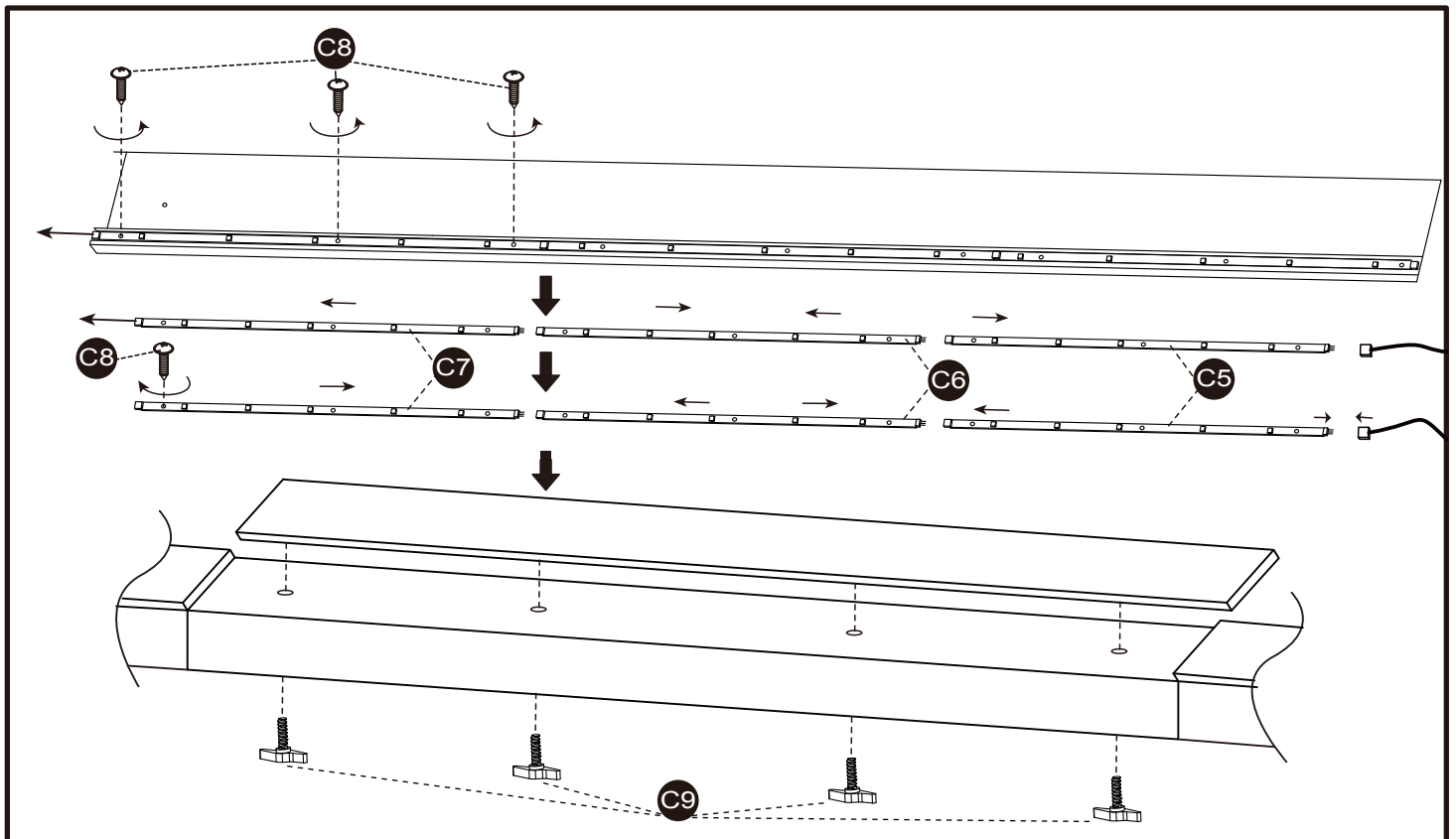

Congratulations! You have now assembled your hockey table. Please note the Care and Use instructions below to insure many years of trouble free use of your hockey table.

CARE AND USE OF YOUR HOCKEY TABLE

1. Use only a suitable 120v AC household outlet, and insure the cord is not a trip hazard.
2. For long life and best play from your air hockey table, apply spray furniture polish to clean cloth and wipe down the playfield with air motor running to make the pucks slide faster before first play and frequently thereafter.
3. This product is intended for **INDOOR** use only.
4. **DO NOT** operate the motor if the A/C Adapter cord is damaged in any way.
5. **DO NOT** sit, climb or lean on the table.
6. **DO NOT** drag the table when moving it. This will damage the legs.
7. **DO NOT** set drinks on the table.
8. It is suggested that this table be placed close to wall thus allowing the A/C Adapter cord to **NOT** be a trip hazard. Always unplug A/C Adapter from wall when table is not in use.
9. Use a carpenters level to properly level table using the leg levelers.

ELECTRICAL CONNECTIONS DRAWINGS

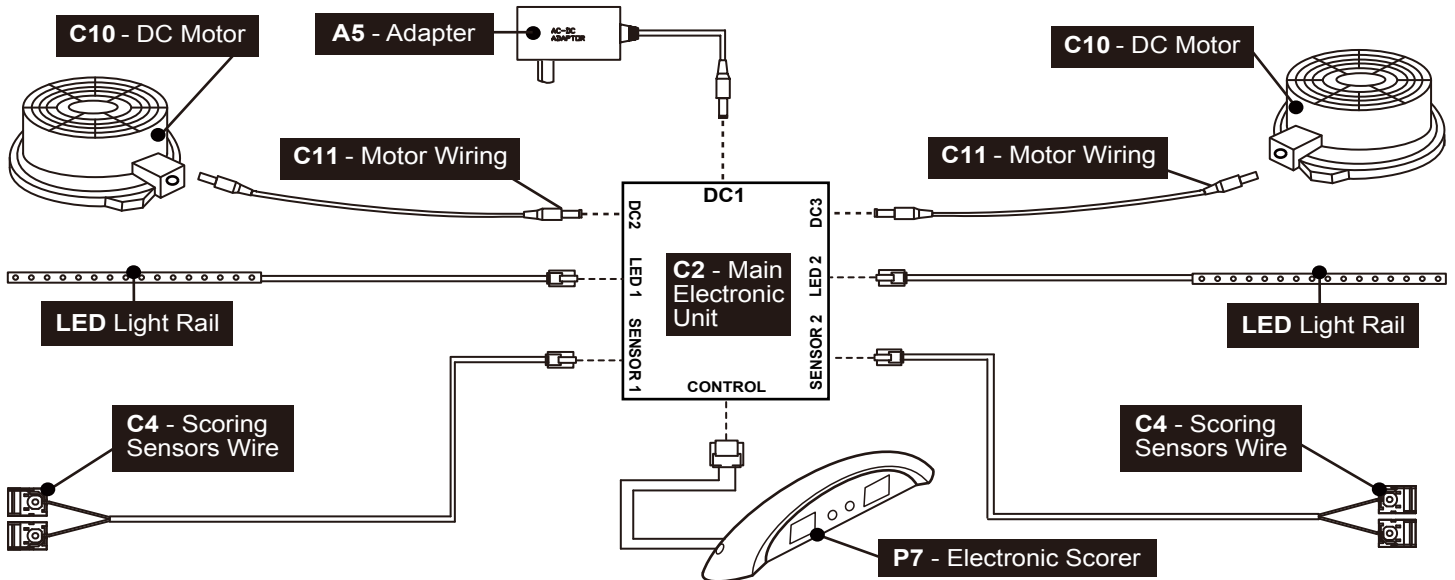

PRODUCT PARTS LIST

45-6800

Part#	Description	Qty	Part#	Description	Qty
45-6800HLH1	8 mm x 28 mm Allen Head Bolt	12	45-6800HLP1	Air Hockey Cabinet (no motor)	1
45-6800HLH2	8.5 mm x 18 mm Flat Washer	12	45-6800HLP2	Right Leg	2
45-6800HLH3	3.5 mm x 12 mm Phillips Round Head Screw	24	45-6800HLP3	Left Leg	2
45-6800HLH4	3.5 mm x 28 mm Phillips Round Head Screw	2	45-6800HLP4	End Leg Panel w Graphic Artwork	2
45-6800HLT1	Allen Wrench	1	45-6800HLP5	End Leg Panel w/o Graphic Artwork	2
45-6800HLA1	BLUE LED Striker	2	45-6800HLP6	Leg Leveler	4
45-6800HLA2	Clear with BLUE LED Puck	1	45-6800HLP7	Electronic Scorer	1
45-6800HLA3	Red Puck	2	45-6800HLC2	Main Electronic Unit (Pre-Installed)	1
45-6800HLA4	Felt Pad	2	45-6800HLC3	Corner Post (Pre-Installed)	4
45-6800HLA5	A/C Adapter	1	45-6800HLC4	Scoring Sensor Wire (Pre-Installed)	2
45-6800HLA6	USB Cable	1	45-6800HLC5	Lighting LED Rail A	2
45-6800HLK1	Hardware Kit	1	45-6800HLC6	Lighting LED Rail B	2
45-6800HLM1	Owner's Manual	1	45-6800HLC7	Lighting LED Rail C	2
			45-6800HLC8	3 x 9mm Philips Round Head Screw	18
			45-6800HLC9	Wing Bolt	8
			45-6800HLC10	DC Motor (Pre-Installed)	2
			45-6800HLC11	Motor Wiring	2

90 DAY LIMITED WARRANTY

This consumer warranty extends to the original consumer purchase of any ESCALADESPORTS Product (hereinafter referred as the "Product").

WARRANTY DURATION: This Product is warranted to the original consumer purchase of a period of 90 days from the original purchase.

WARRANTY COVERAGE: ESCALADE SPORTS warrants to the original Consumer Purchaser that any Product of its manufacture is free from defects in material and workmanship when used for the intended purpose under normal use and conditions. THIS WARRANTY IS VOID IF THE PRODUCT HAS BEEN DAMAGED BY ACCIDENT, UNREASONABLE USE, NEGLIGENCE, IMPROPER SERVICE, FAILURE TO FOLLOW INSTRUCTIONS PROVIDED WITH THE PRODUCT OR OTHER CAUSES NOT ARISING OUT OF DEFECTS IN MATERIAL AND WORKMANSHIP.

WARRANTY PERFORMANCE: During the above 90 day warranty period, ESCALADESPORTS shall repair or replace with a comparable model, and Product, or component thereof, which may prove defective under normal use and proper care, and which our examination shall disclose to our satisfaction to be thus defective, please contact our Warranty Dept.

1-888-996-2729 / Warranty Dept.

Or Write us at:

Escalade® Sports, Inc. - P.O. Box 889, Evansville, IN 47706

Attn: Warranty Dept.

Or E-mail us at:

gamerom@escaladesports.com

Other than shipping requirements no charge will be made for such repair or replacement of in-warranty Products. ESCALADE SPORTS strongly recommends that the Product is insured for value prior to mailing.

WARRANTY DISCLAIMERS: ANY IMPLIED WARRANTIES ARISING OUT OF THIS SALE, INCLUDING BUT NOT LIMITED TO THE IMPLIED WARRANTIES OF MERCHANTABILITY AND FITNESS FOR A PARTICULAR PURPOSE, ARE LIMITED IN DURATION TO THE ABOVE 90 DAY PERIOD. ESCALADE SPORTS SHALL NOT BE LIABLE FOR LOSS OF USE OF THE PRODUCT OR OTHER CONSEQUENTIAL OR INCIDENTAL COSTS, EXPENSES OR DAMAGES INCURRED BY THE CONSUMER OF ANY OTHER USE.

Some states do not allow the exclusion or limitation of implied warranties or consequential or incidental damages, so the above limitations or exclusions may not apply to you.

LEGAL REMEDIES: This warranty gives you specific legal rights and you may also have other rights which may vary from state to state.