

X2

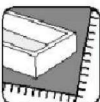

01:30



À MONTER
SOI-MÊME



6+

GB WARNING

IMPORTANT – READ CAREFULLY – RETAIN FOR FUTURE REFERENCE



- a) **WARNING** "Bunk beds and the upper bed of bunk beds are not suitable for children under six years due to the risk of injury from falls."
- b) **WARNING** "Bunk beds can present a serious risk of injury from strangulation if not used correctly. Never attach or hang items to any part of the bunk bed that are not designed to be used with the bed, for example, but not limited to ropes, trings, cords, hooks, belts and bags."
- c) **WARNING** "Children can become trapped between the bed and the wall, a roof pitch, the ceiling, adjoining piece of furniture (e.g. cupboards) and the like. To avoid risk of serious injury the distance between the top safety barrier and the adjoining structure must not exceed 75mm or must be more than 230 mm."
- d) **WARNING** "Do not use the bunk bed if any structural part is broken or missing."
- e) **WARNING** "Always follow the manufacturer's instructions."
- f) **RECOMMENDATION:** The recommended size of the mattress(es): 2000 × 900×100 mm. The max thickness of the mattress is 130mm.
- g) **NOTE:** Ventilation of the room is necessary in order to keep the humidity low and to prevent mould in and around the bed.
- h) **NOTE:** Check regularly that all assembly fastenings are properly tightened.
- i) **NOTE:** Always ensure the ladder / stairs are permanently attached to this bunk bed before use.
- j) **NOTE:** This product must be attached to a wall or building structure.
- k) The bed meets the requirements of the standard: **DIN EN747-1:2024;DIN EN747-2:2024**
- l) Please note safety label on the bed. It is prohibited to remove this label. **Pay attention to the marking for the maximum mattress height.**



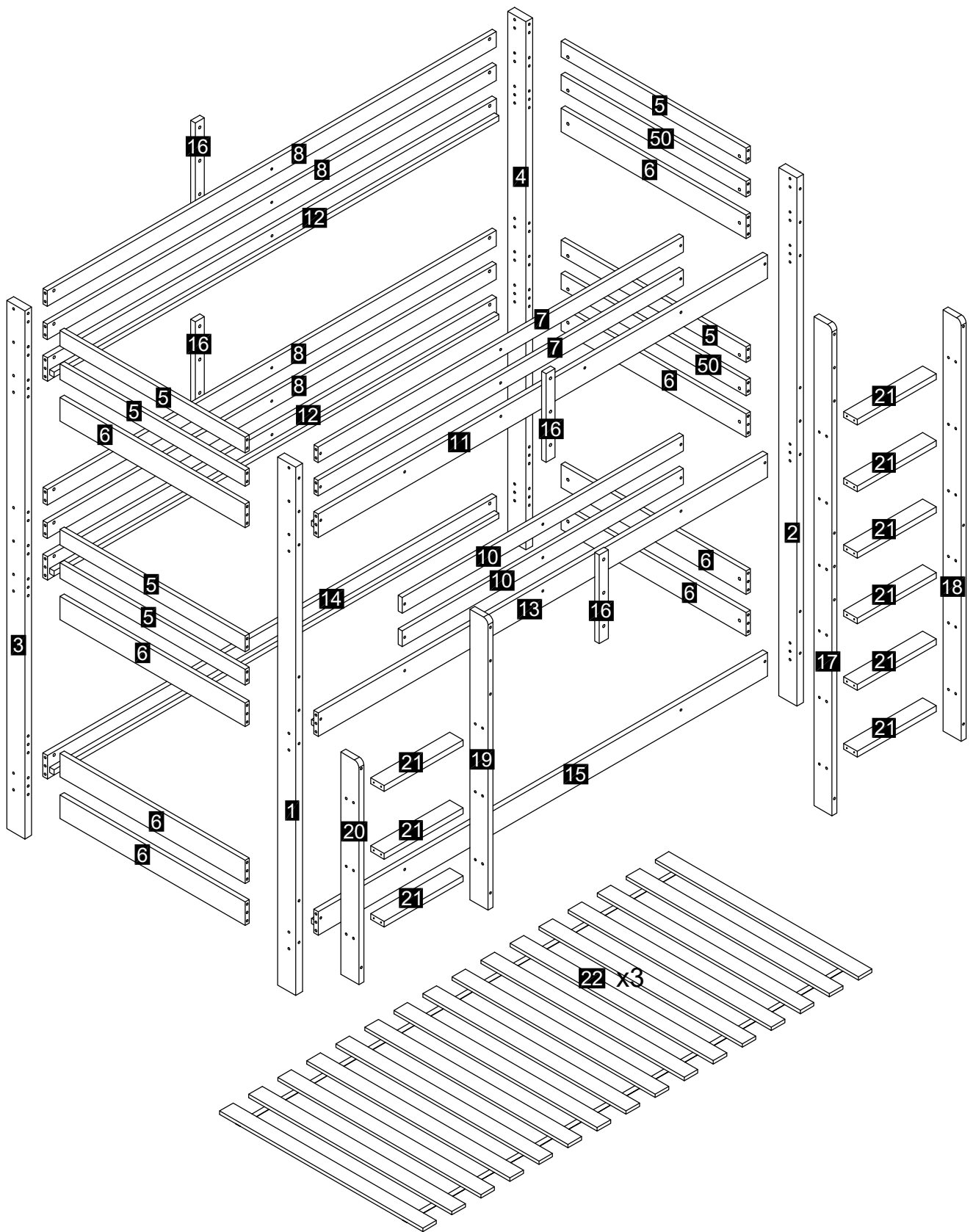

DE WARNHINWEIS



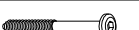

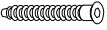
WICHTIG – SORGFÄLTIG LESEN – FÜR SPÄTERES NACHSCHLAGEN AUFBEWAHREN

- a) **WARNHINWEIS** „Etagenbetten und das obere Bett von Etagenbetten sind wegen der Verletzungsgefahr durch Herabfallen nicht für Kinder unter sechs Jahren geeignet.“
- b) **WARNHINWEIS** „Etagenbetten können ein ernsthaftes Verletzungsrisiko durch Strangulation darstellen, wenn sie nicht richtig benutzt werden. Hängen Sie niemals Gegenstände an irgendeinen Teil des Etagenbettes, die dafür nicht konzipiert wurden, zum Beispiel Seile, Schnüre, Kordeln, Haken, Gürtel und Taschen.“
- c) **WARNHINWEIS** „Kinder können zwischen Bett und Wand, Dachschräge, Zimmerdecke, naheliegende Möbelstücke (z.B. Schränke) und ähnlichem eingeklemmt werden. Um ernsthafte Verletzungen zu vermeiden, sollte der Abstand zwischen der oberen Sicherheitsbarriere und der Wand nicht größer als 75 mm oder größer als 230 mm sein.“
- d) **WARNHINWEIS** „Verwenden Sie das Etagenbett nicht, wenn Bauteile fehlen oder defekt sind.“
- e) **WARNHINWEIS** „Befolgen Sie immer die Anweisungen des Herstellers.“
- f) **EMPFEHLUNG:** Die empfohlene Matratzengröße(n): 2000×900×100 mm. Die maximale Dicke der Matratze beträgt 130mm.
- g) **HINWEIS:** Eine ausreichende Belüftung des Raums ist erforderlich, um die Luftfeuchtigkeit niedrig zu halten und Schimmelbildung in und um das Bett zu vermeiden.
- h) **HINWEIS:** Prüfen Sie regelmäßig, ob alle Befestigungen festgezogen sind.
- i) **HINWEIS:** Stellen Sie vor der Verwendung immer sicher, dass die Leiter/Treppe dauerhaft an dem Etagenbett befestigt sind.
- j) **HINWEIS:** Dieses Produkt muss an einer Wand oder Gebäudestruktur befestigt werden.
- k) Das Bett stimmt mit den Sicherheitsanforderungen der Norm überein: **DIN EN747-1:2024;DIN EN747-2:2024.**
- l) Bitte beachte den Sicherheitsaufkleber auf dem Bett. Dieser darf nicht entfernt werden.
Achten Sie auf die Markierung für die maximale Matratzenhöhe.





A		Φ8*30mm	72
B		M6*120mm	32
C			66
D		M6*70mm	34

E		Φ7*50mm	36
F		M6*90mm	16
G		M8*20mm	28
H		M6*25mm	12

I		Φ4*30mm	96
J			2
K		Φ4*20mm	2
L			2
M		4 mm	2

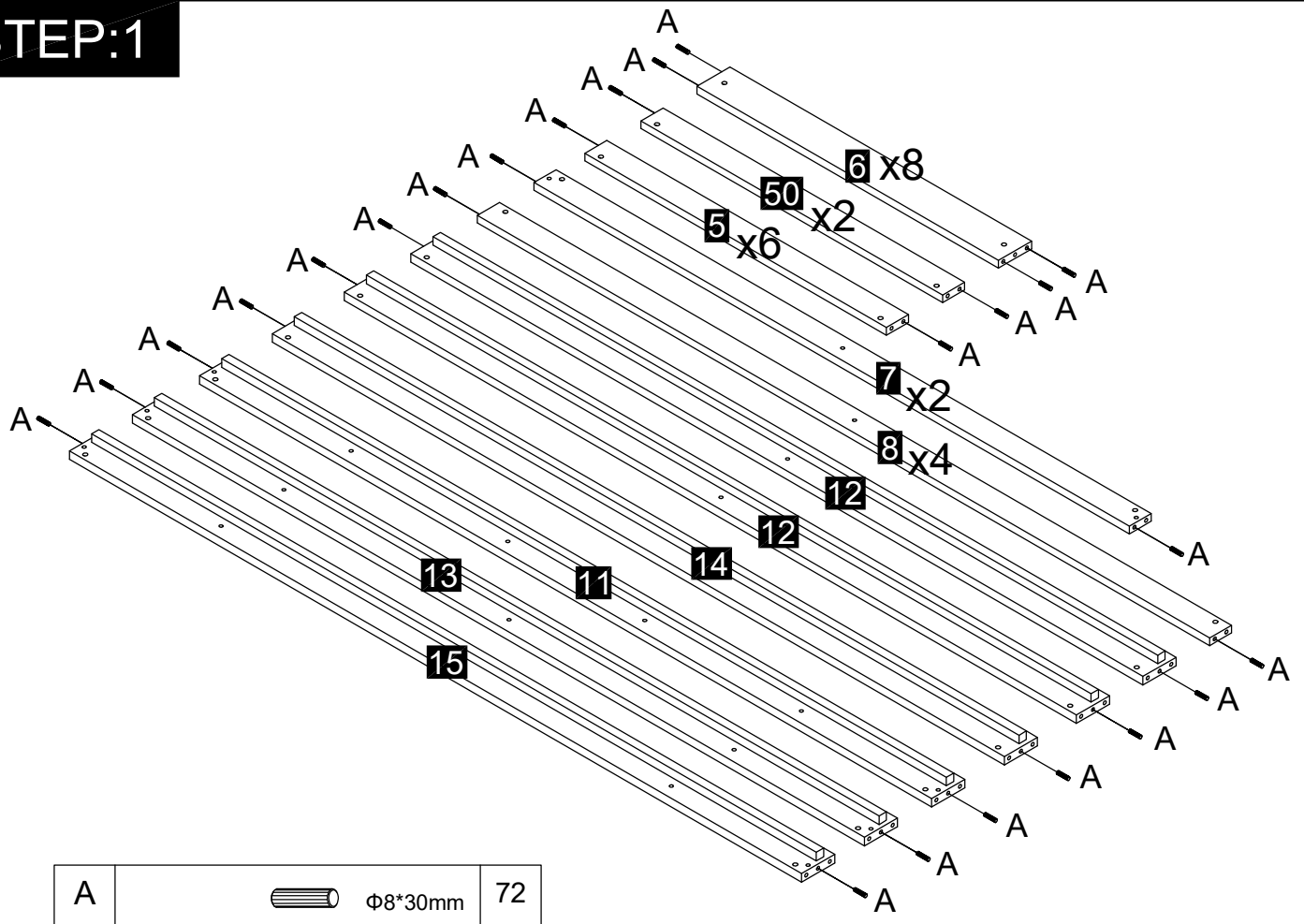

STEP:1

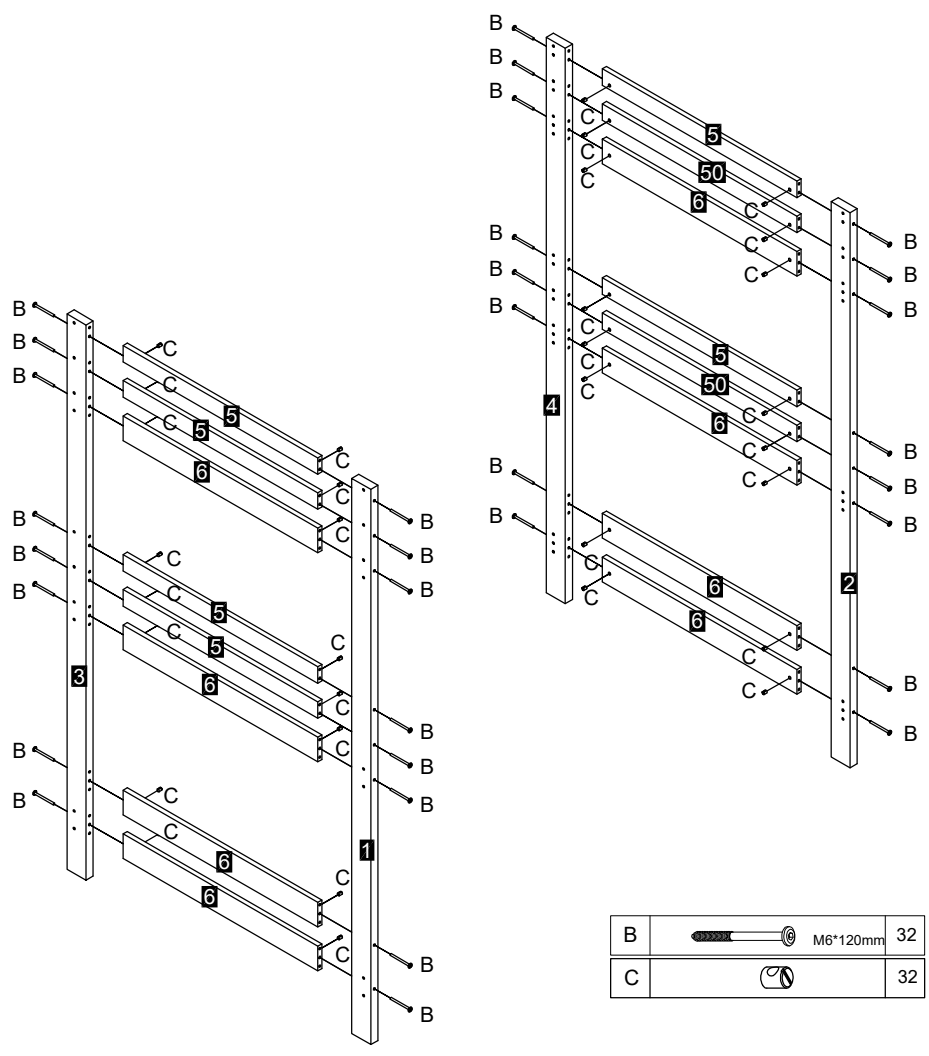

A		Φ8*30mm	72
---	--	---------	----

STEP:2



B		M6*120mm	32
C			32

STEP:3

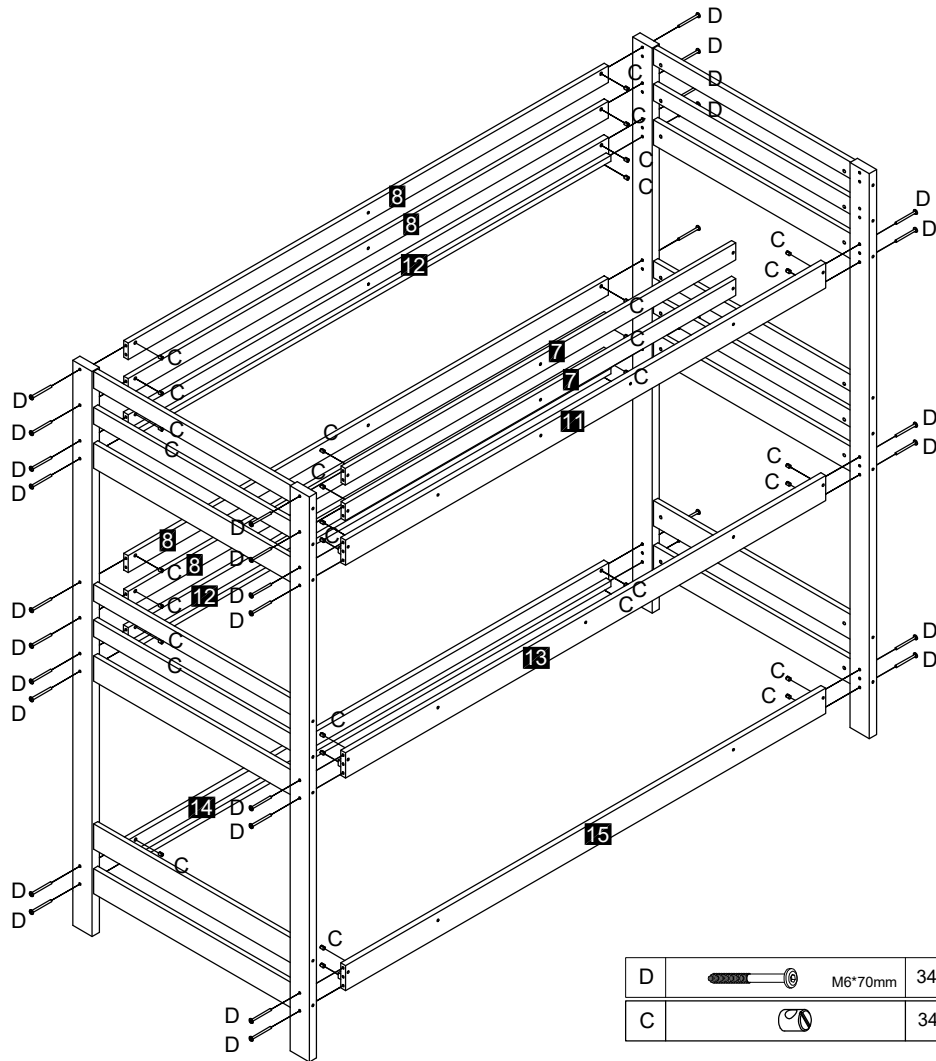

STEP:4

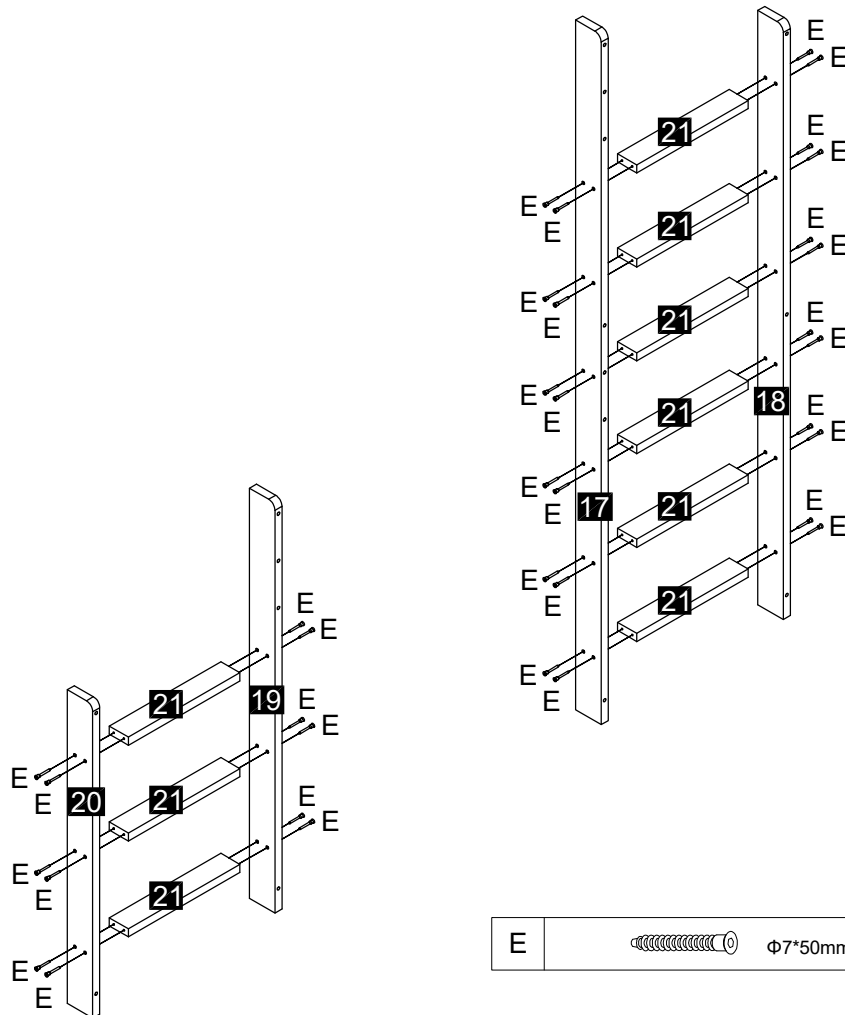

STEP:5

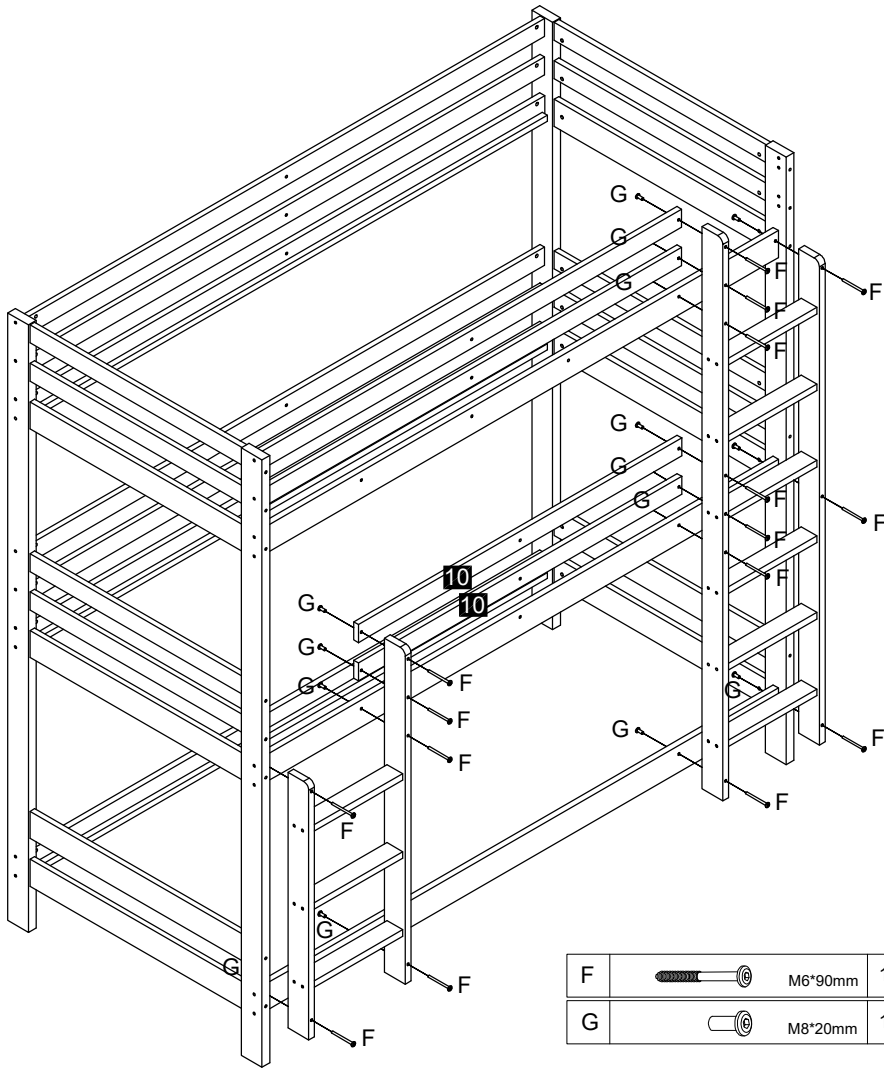

STEP:6

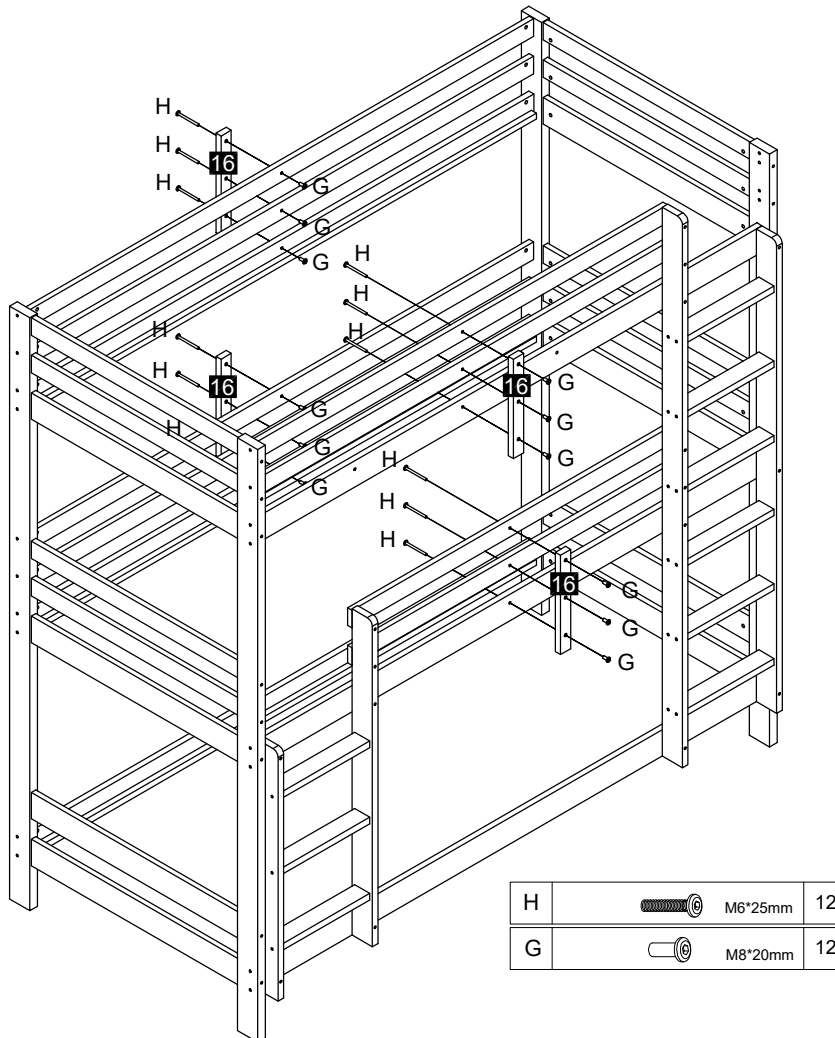

STEP:7



HOMESTYLE4U

Hersteller / Manufacturer / Fabricant:

Homestyle4u GmbH & Co. KG

Sudenburger Wuhne 61

DE-39116 Magdeburg



DIN EN 747-1:2024+2:2024

D: Maximale Höhe der Matratze.
Das Bett muss an einer Wand befestigt werden.





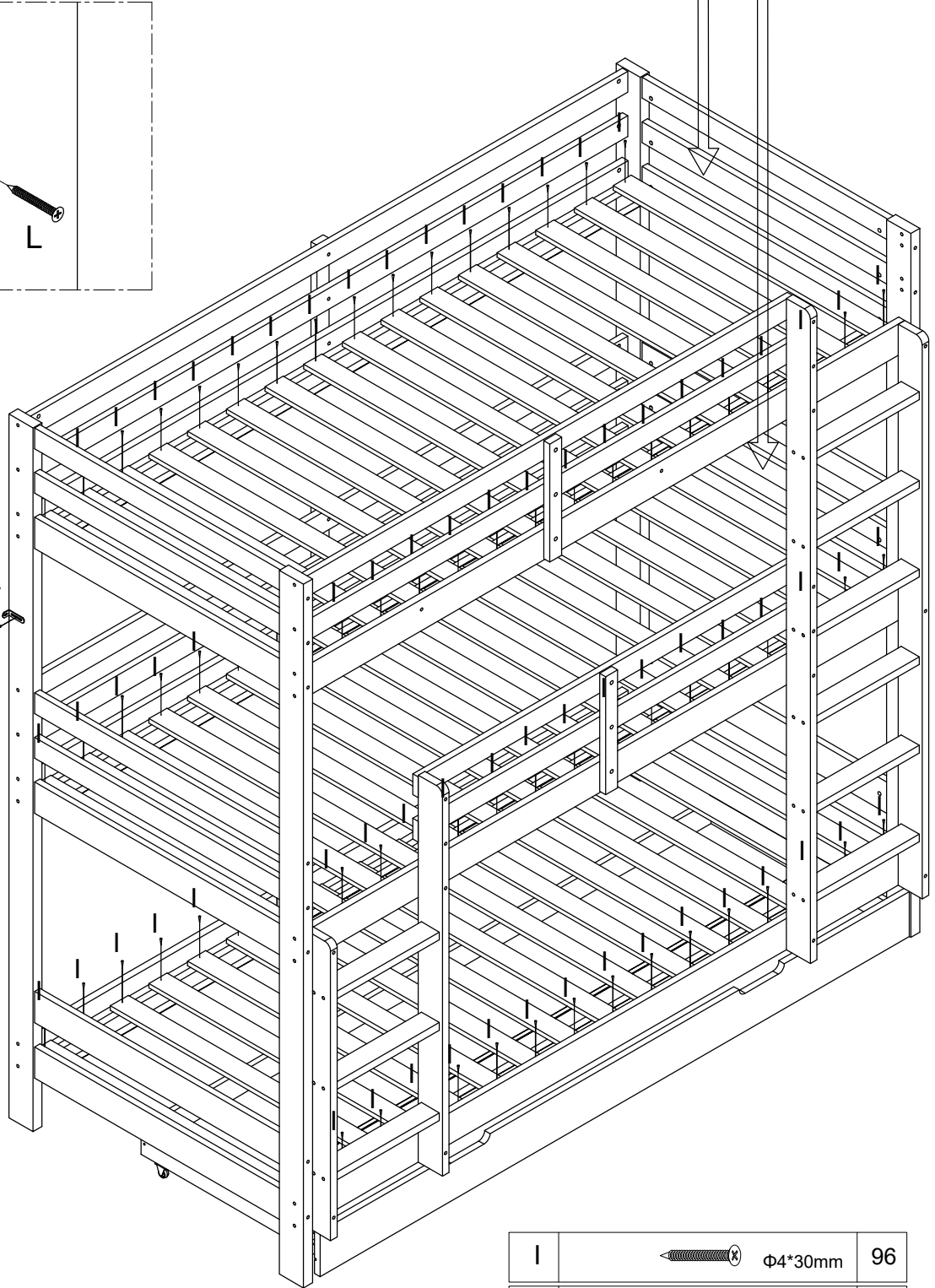
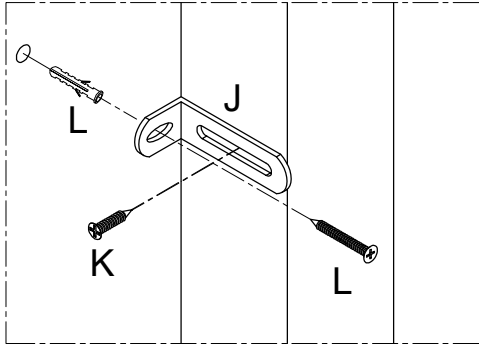

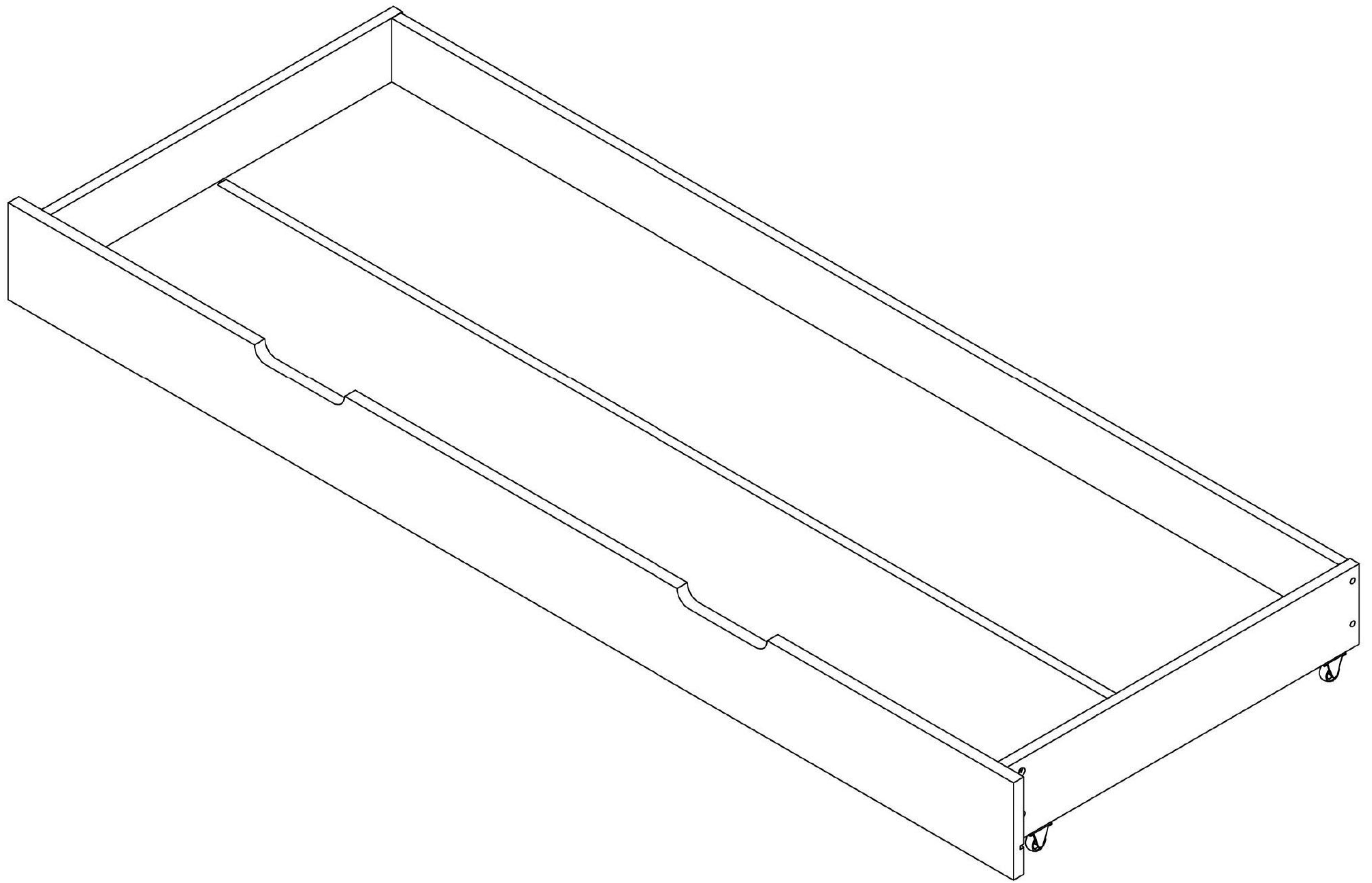

GB: Maximum Height of mattress.
This bed must be attached to a wall.

F: Hauteur maximum du matelas.
Le lit doit être fixé à un mur.



I		Φ4*30mm	96
J			2
K		Φ4*20mm	2
L			2



A		10
B		10
C	 $\phi 4*40$	4
D		4
E	 $\phi 8*30$	6
F	 $3*16$	8
G	 1855 mm	1
H		1

STEP:1

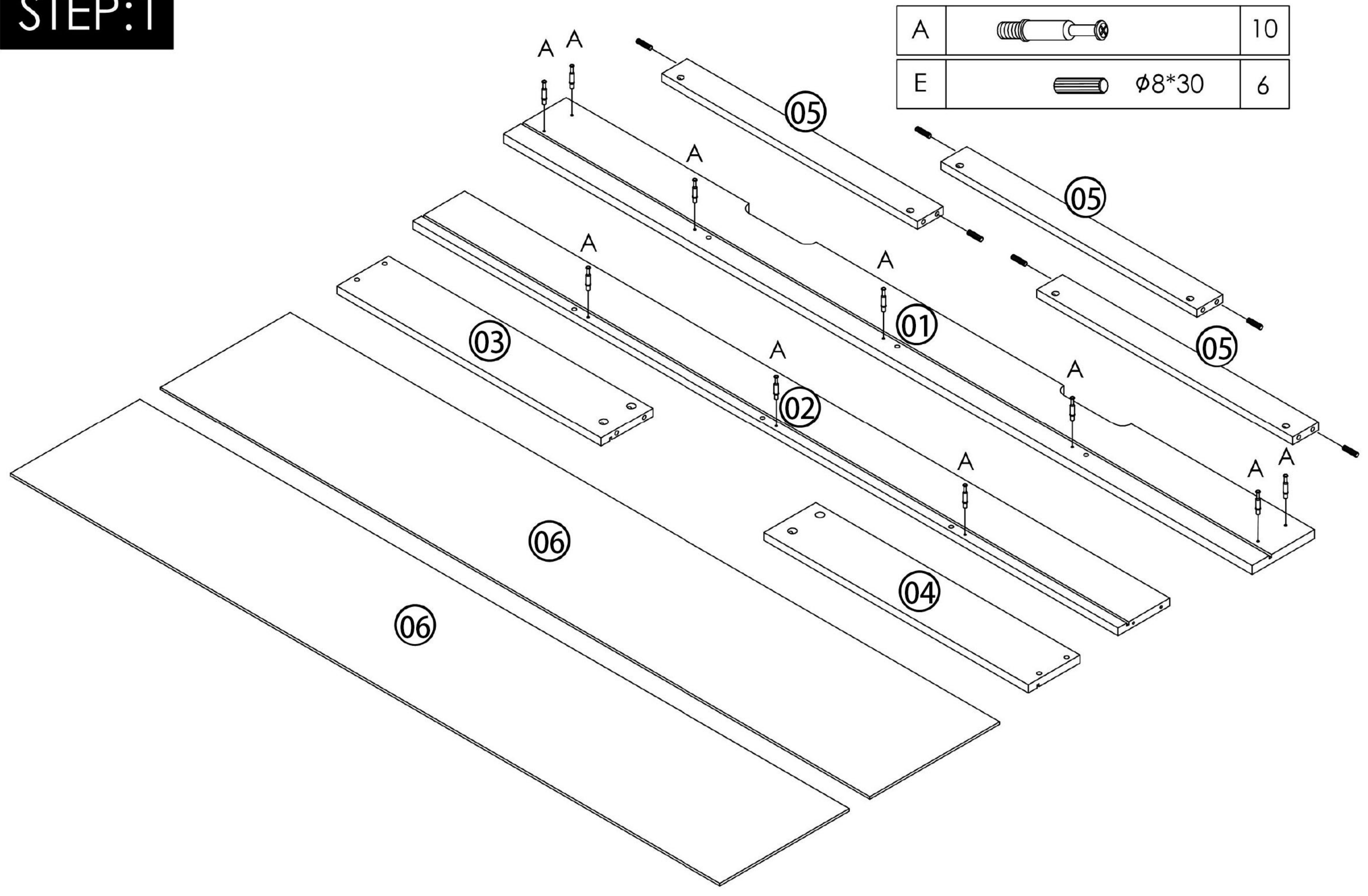

STEP:2

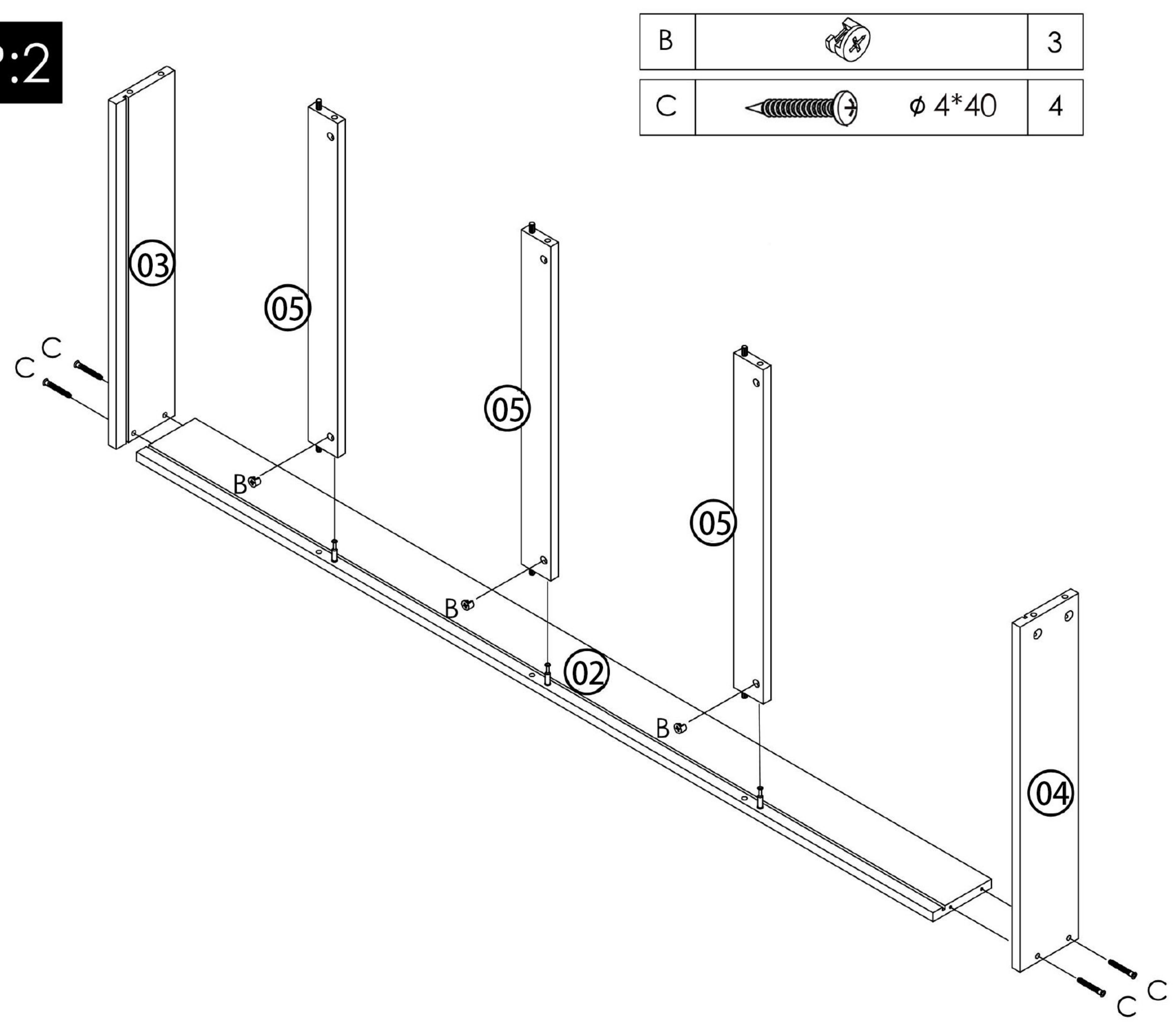

STEP:3

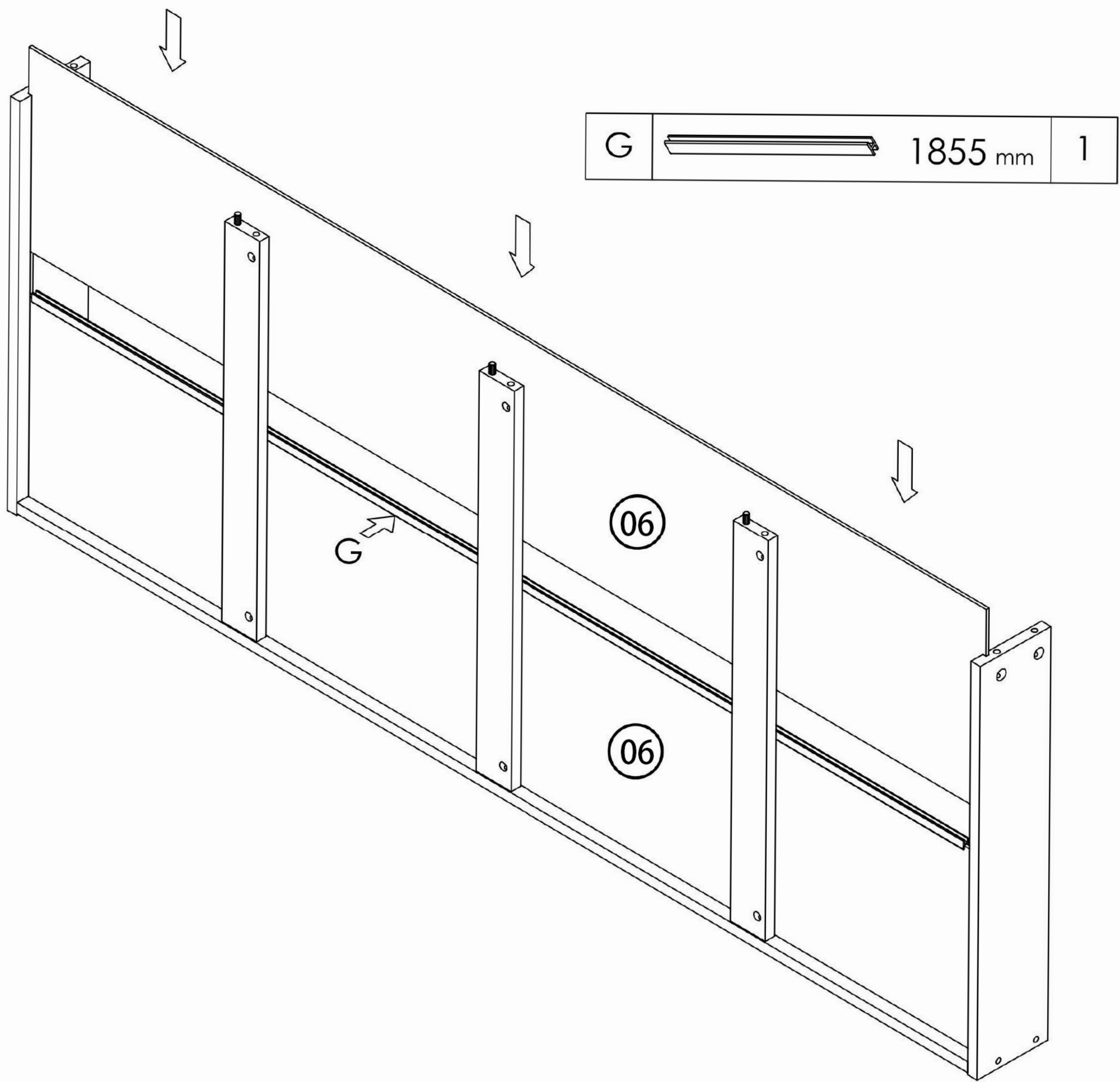

STEP:4

