

# ASSEMBLY INSTRUCTIONS

## KITCHEN CART

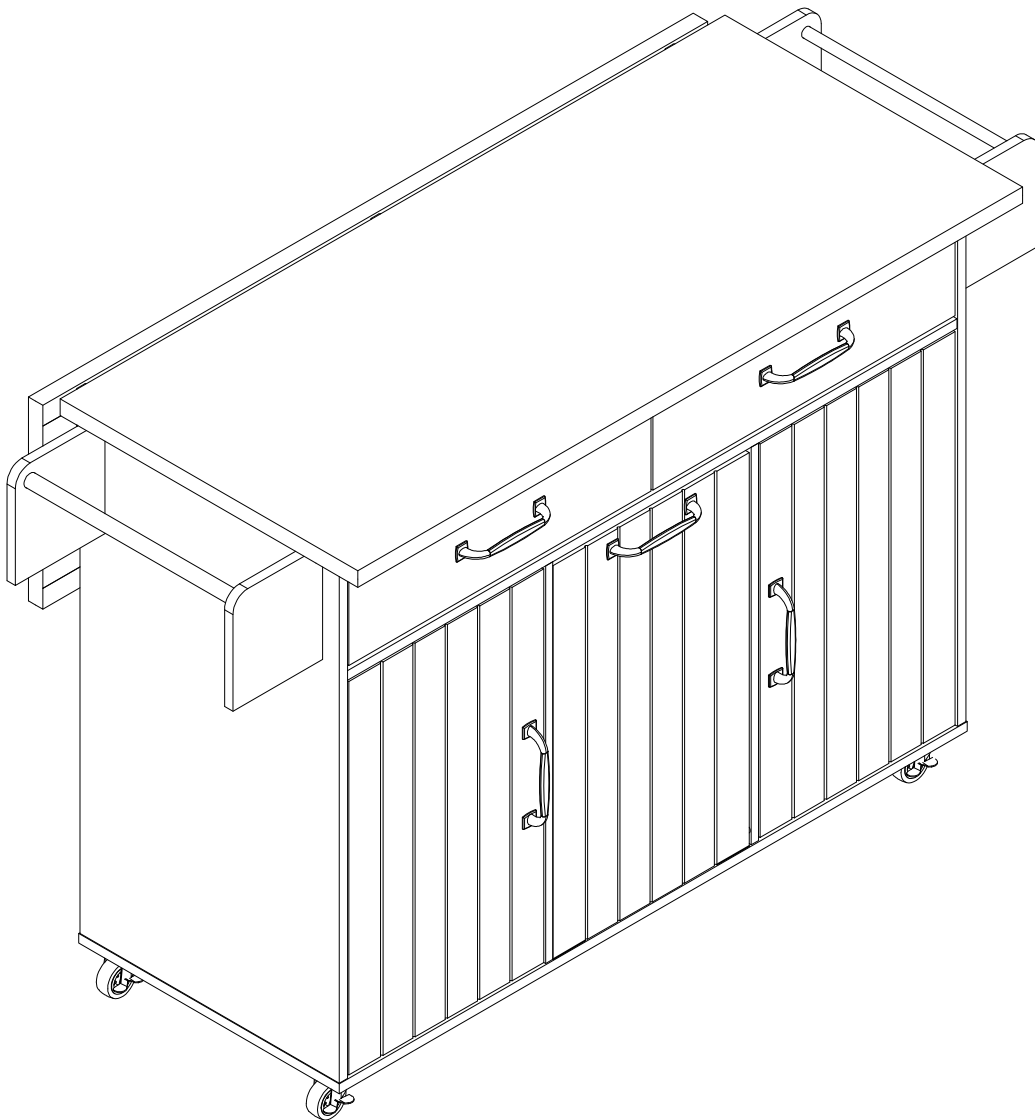

N707P458308  
N707P458309

! WARNING	
	<p>This product is NOT a Clothing Storage Unit (CSU).</p> <p>DO NOT use it for clothing storage.</p> <p>Improper use may cause furniture tipover.</p>

# Detail View

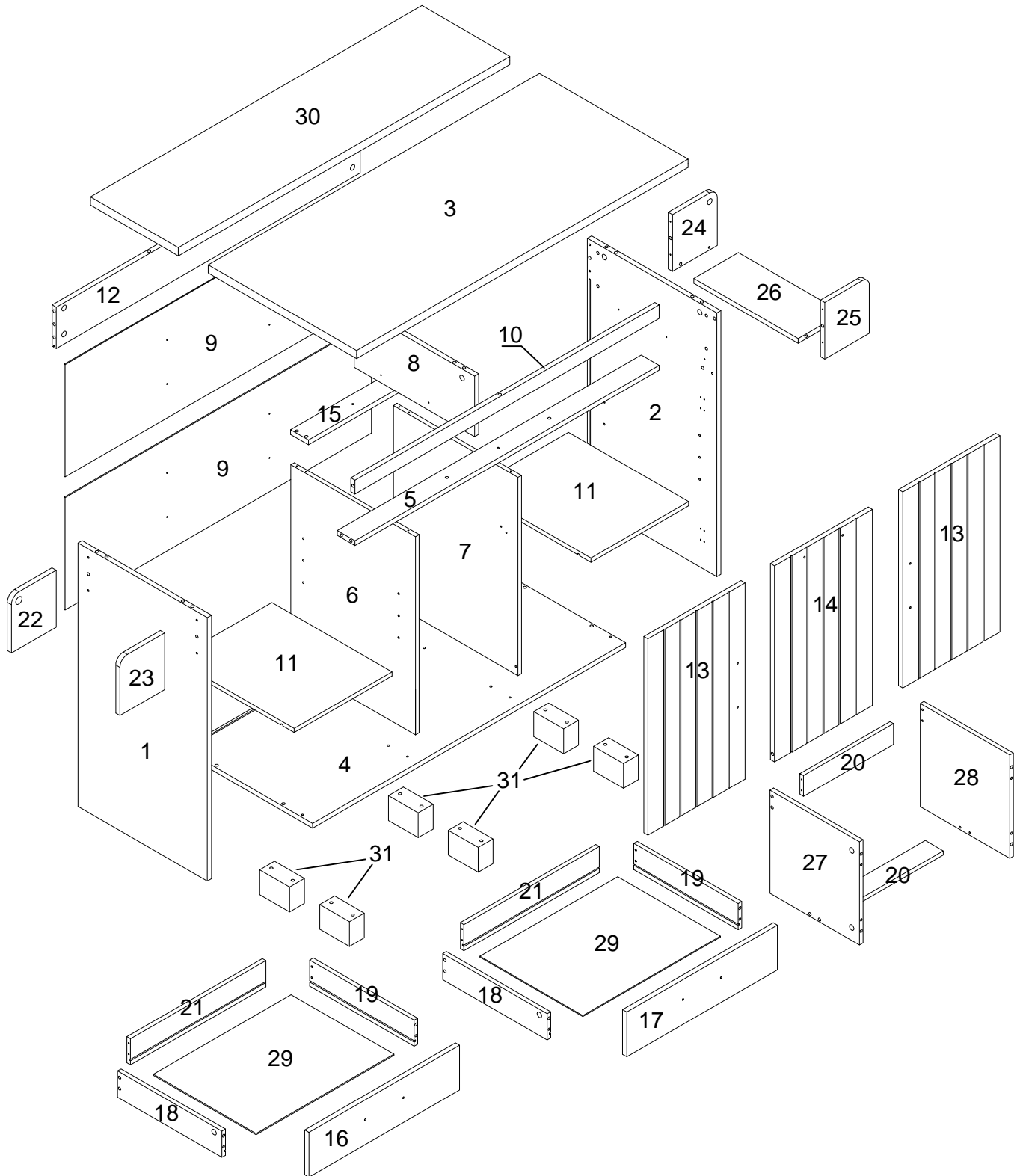

# Part List

## N707P458308

11

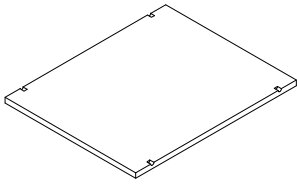

Shelf Panel - 2pcs

13

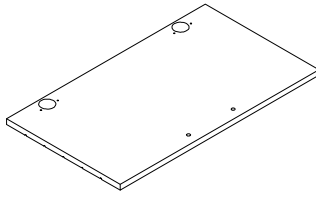

Door Panel (Left) - 2pcs

14

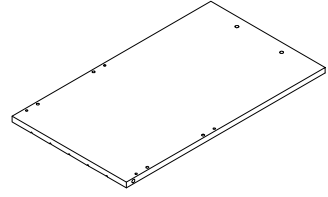

Door Panel (Center) - 1pc

15

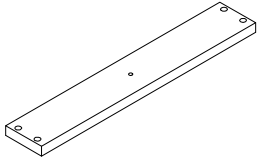

Support Center Panel - 1pc

18

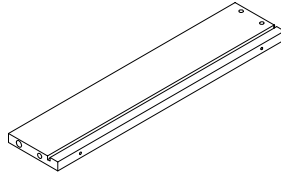

Left Panel (Drawer) - 2pcs

19

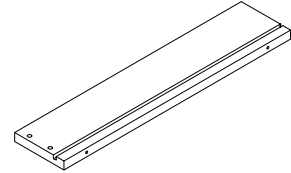

Right Panel (Drawer) - 2pcs

20

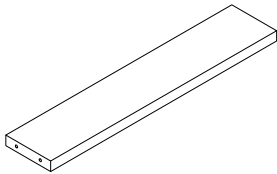

Support Center Drawer - 2pcs

21

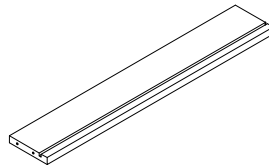

Back Panel (Drawer) - 2pcs

22

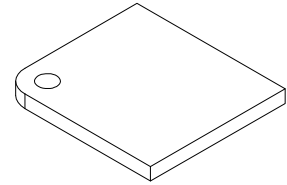

Left Panel (PVC Pipe) - 1pc

23

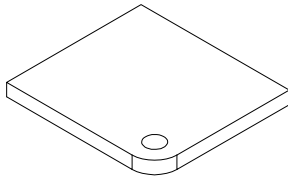

Right Panel (PVC Pipe) - 1pc

24

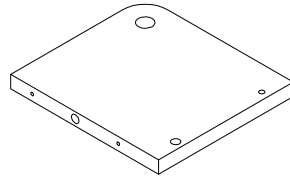

Right Panel (Wooden Rod) - 1pc

25

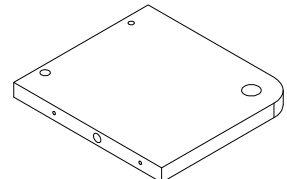

Left Panel (Wooden Rod) - 1pc

26

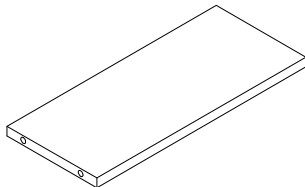

Center Panel (PVC Pipe) - 1pc

27

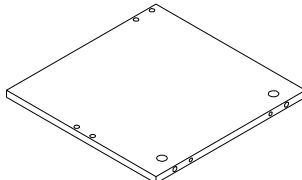

Left Panel Compartment (Center) - 1pc

28

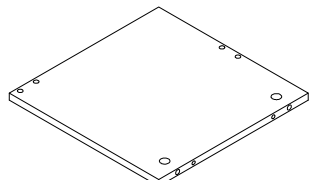

Right Panel Compartment (Center) 1pc

31

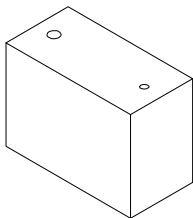

Bottom Panel (Leg) - 6pcs





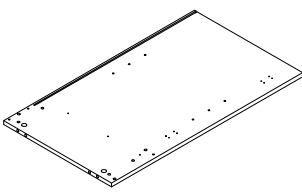
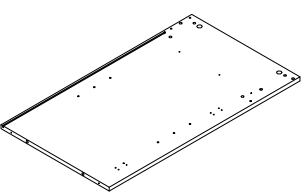
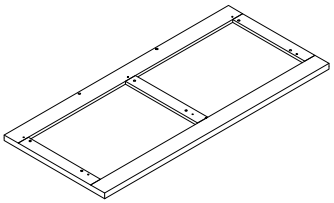
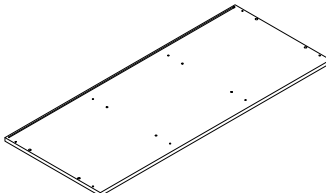
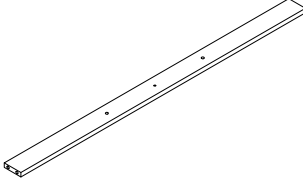
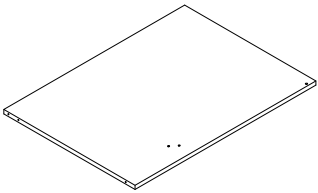
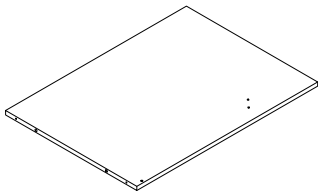
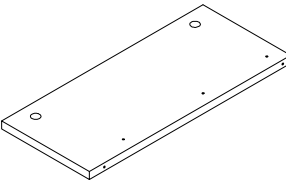
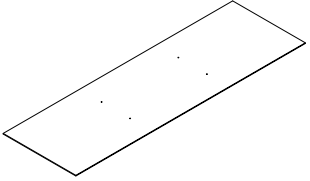
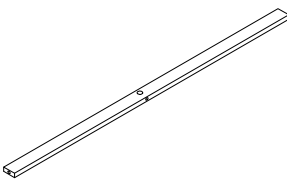
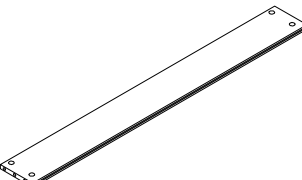
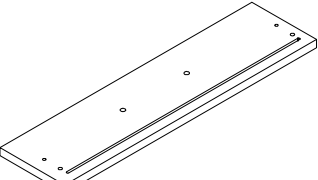
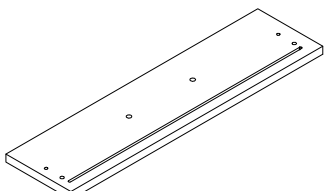
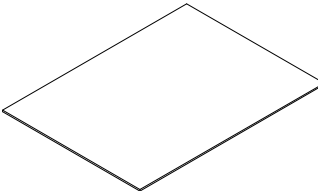
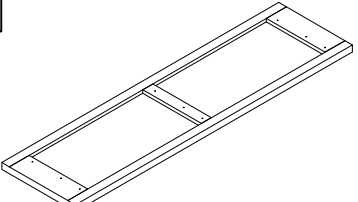





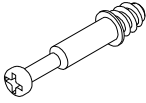

# Part List

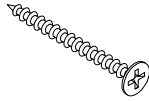
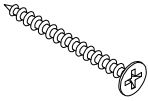
## N707P458309

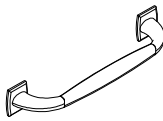
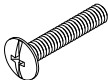
<p>1</p>  <p>Side Panel (Left) - 1pc</p>	<p>2</p>  <p>Side Panel (Right) - 1pc</p>	<p>3</p>  <p>Top Panel - 1pc</p>
<p>4</p>  <p>Bottom Panel - 1pc</p>	<p>5</p>  <p>Drawer Support Panel - 1pc</p>	<p>6</p>  <p>Left Panel (Center) - 1pc</p>
<p>7</p>  <p>Right Panel (Center) - 1pc</p>	<p>8</p>  <p>Center Panel (Drawer) - 1pc</p>	<p>9</p>  <p>Back Panel - 2pcs</p>
<p>10</p>  <p>Horizontal Panel (Top) - 1pc</p>	<p>12</p>  <p>Back Panel (Top) - 1pc</p>	<p>16</p>  <p>Front Panel Drawer (Left) - 1pc</p>
<p>17</p>  <p>Front Panel Drawer (Right) - 1pc</p>	<p>29</p>  <p>Bottom Panel (Drawer) - 2pcs</p>	<p>30</p>  <p>Extend Top Panel - 1pc</p>

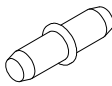
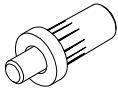
# Hardware List

## N707P458308

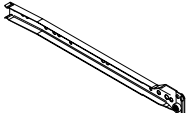
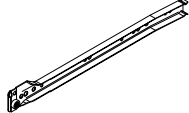
<b>A</b>  Ø6x33mm Cam Bolt (23+3pcs)	<b>B</b>  Ø5x10mm Cam Nut (23+3pcs)	<b>C</b>  Ø8x30mm Wood dowel (24+2pcs)
<b>D</b>  Ø6x30mm Wood dowel (18+2pcs)	<b>E</b>  Ø4x45mm Chip Board Screw (16+2pcs)	<b>F</b>  Ø4x35mm Chip Board Screw (24+2pcs)
<b>G</b>  Ø3.5x16mm Chip Board Screw (35+3pcs)	<b>H</b>  Ø3.5x14mm Chip Board Screw (44+3pcs)	<b>I1</b>  Handle (5pcs)
<b>I2</b>  Ø4x18mm T/MS Handle Screw (10+1pcs)	<b>J</b>  Ø6.4x1.6mm Washer (20+2pcs)	<b>K</b>  Shelf Support (Steel) (8pcs)
<b>L</b>  Shelf Support (Steel)(Big) (2pcs)	<b>M</b>  Door Stopper (2pcs)	<b>N1</b>  Single Plastic Cap (9pcs)
<b>N2</b>  Ø3x16mm Chip Board Screw (9pcs)	<b>CR</b>  Wall Right (2pcs)	<b>CL</b>  Wall Left (2pcs)



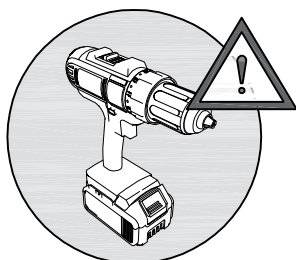
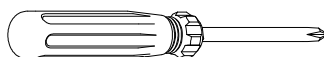





### ASSEMBLY TOOLS REQUIRED (NOT INCLUDED )

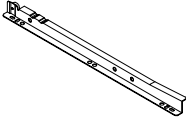
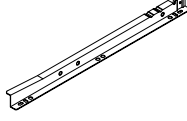
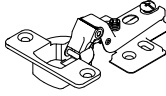
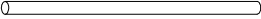

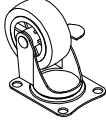
PLEASE BE CAREFUL DO NOT DAMAGE THE HOLE POSITION WHEN YOU USE POWER TOOLS !

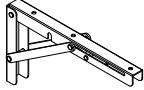
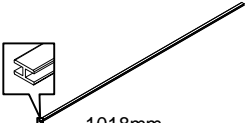
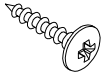
# Hardware List

## N707P458308



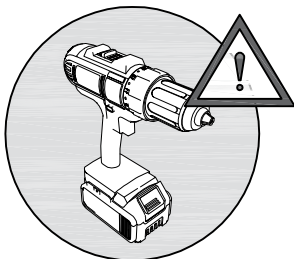
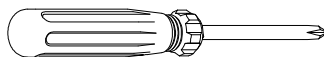

<b>DR</b> 	<b>DL</b> 	<b>P</b> 
Drawer Right (2pcs)	Drawer Left (2pcs)	Hinges (4pcs)
<b>Q</b> 	<b>R</b> 	<b>S1</b> 
PVC Pipe (365mm) (1pc)	Wooden Rod (365mm) (1pc)	Stopper Nylon Caster (4pcs)
<b>S2</b> 	<b>T</b>  Ø6x50mm	<b>U</b> 
Nylon caster without brake (1pc)	JCBC Screw (6pcs)	10° L-Shape Metal (3pcs)
<b>V</b>  1018mm	<b>W</b>  Ø3.5x16mm	<b>X</b> 
PVC H-Lining (1pc)	pan head screw (8pcs)	Door Buffer (2pcs)
<b>Y</b>  M4 Allen Key (1pc)	<b>Z</b>  screwdriver (1pc)	

### ASSEMBLY TOOLS REQUIRED (NOT INCLUDED )



PLEASE BE CAREFUL DO NOT DAMAGE THE HOLE POSITION WHEN YOU USE POWER TOOLS !

**STEP1:**

<b>A</b> 	<b>H</b> 	<b>CR</b> 	<b>CL</b> 
13 pcs	6 pcs	1 pc	1 pc

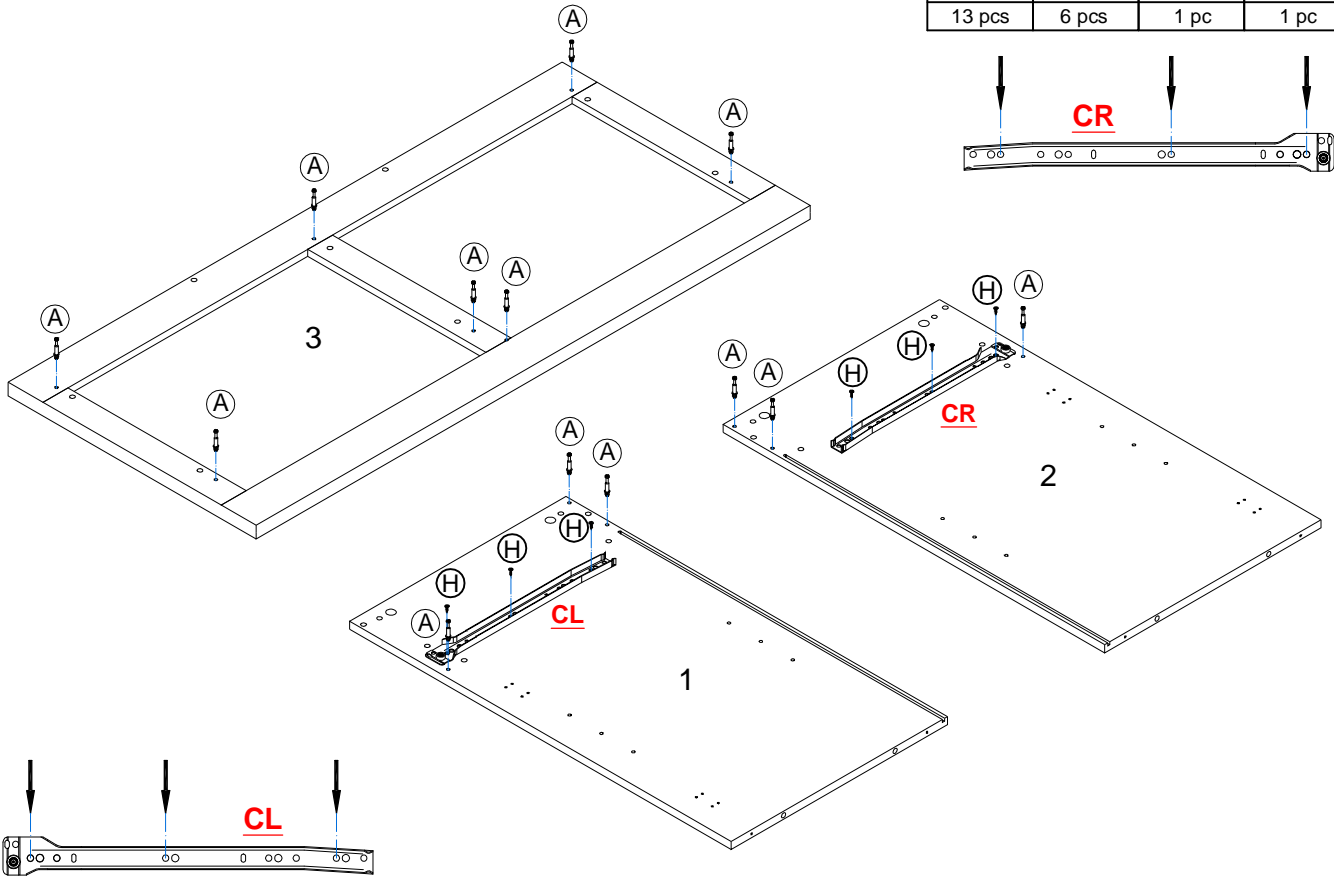

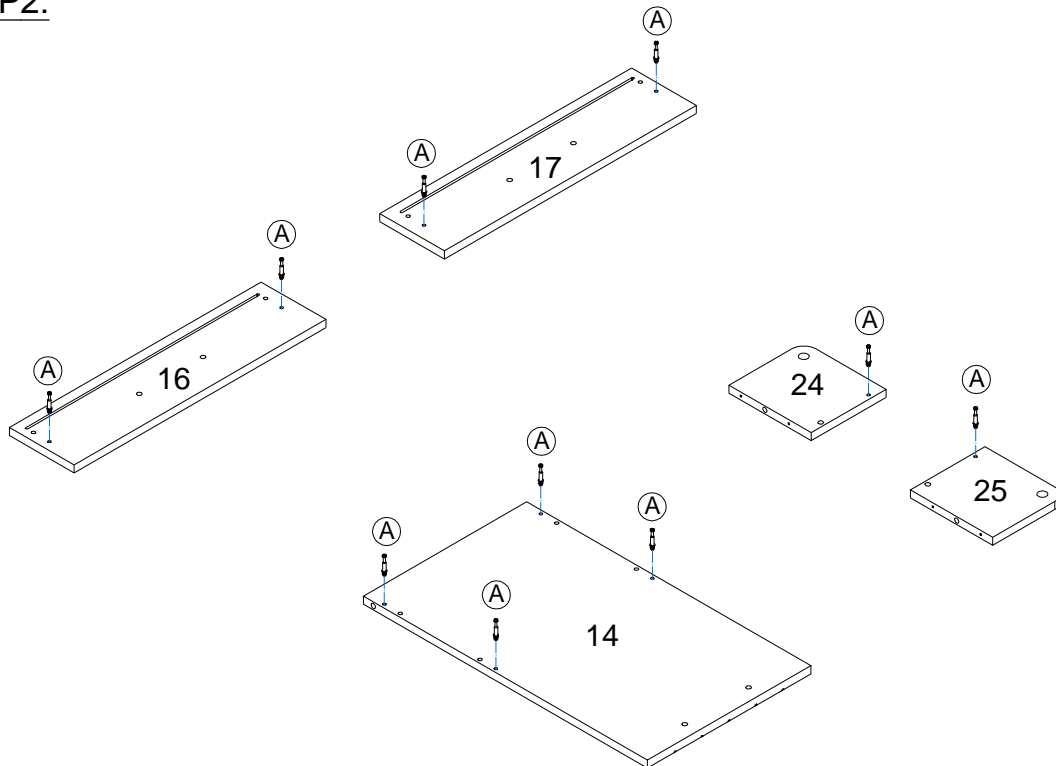

**STEP2:**

<b>A</b> 
10 pcs





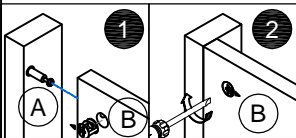
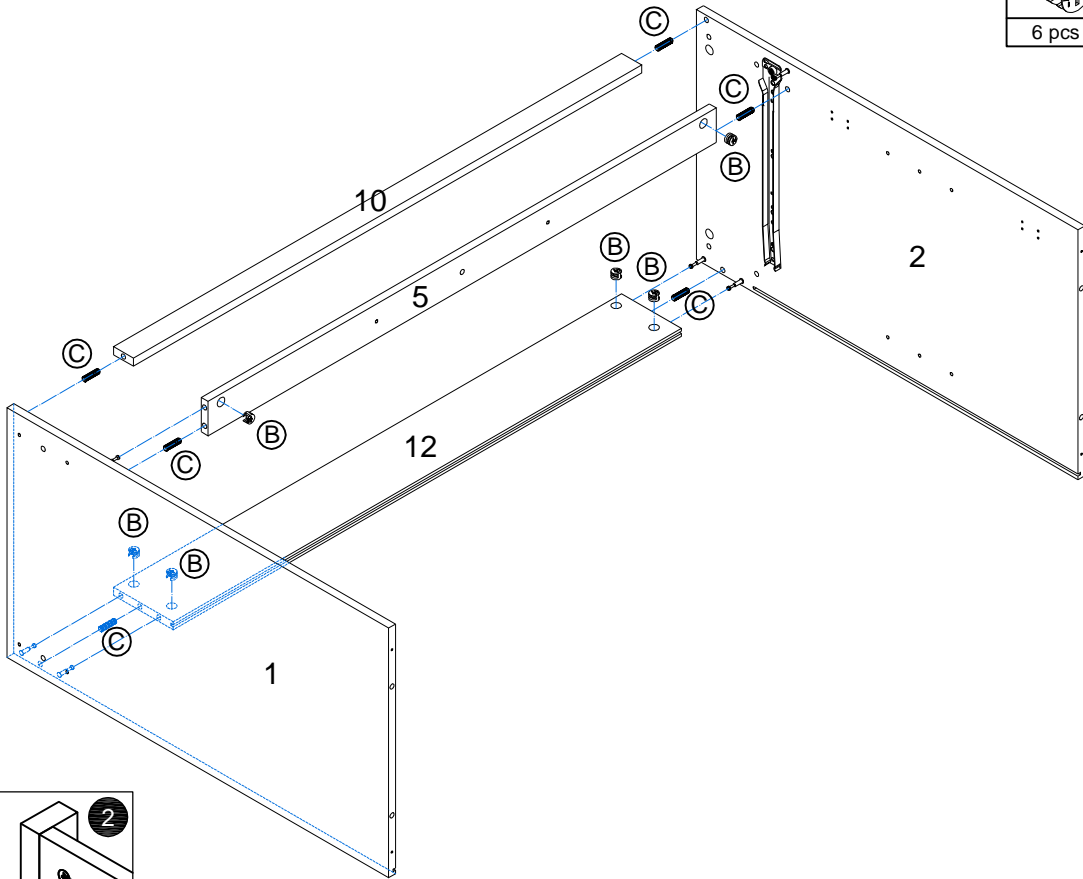

**STEP3:**

<b>B</b>	<b>C</b>
	
6 pcs	6 pcs



**STEP4:**

<b>B</b>	<b>C</b>	<b>E</b>	<b>Q</b>	<b>R</b>
				
2 pcs	6 pcs	8 pcs	1 pc	1 pc

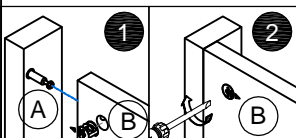
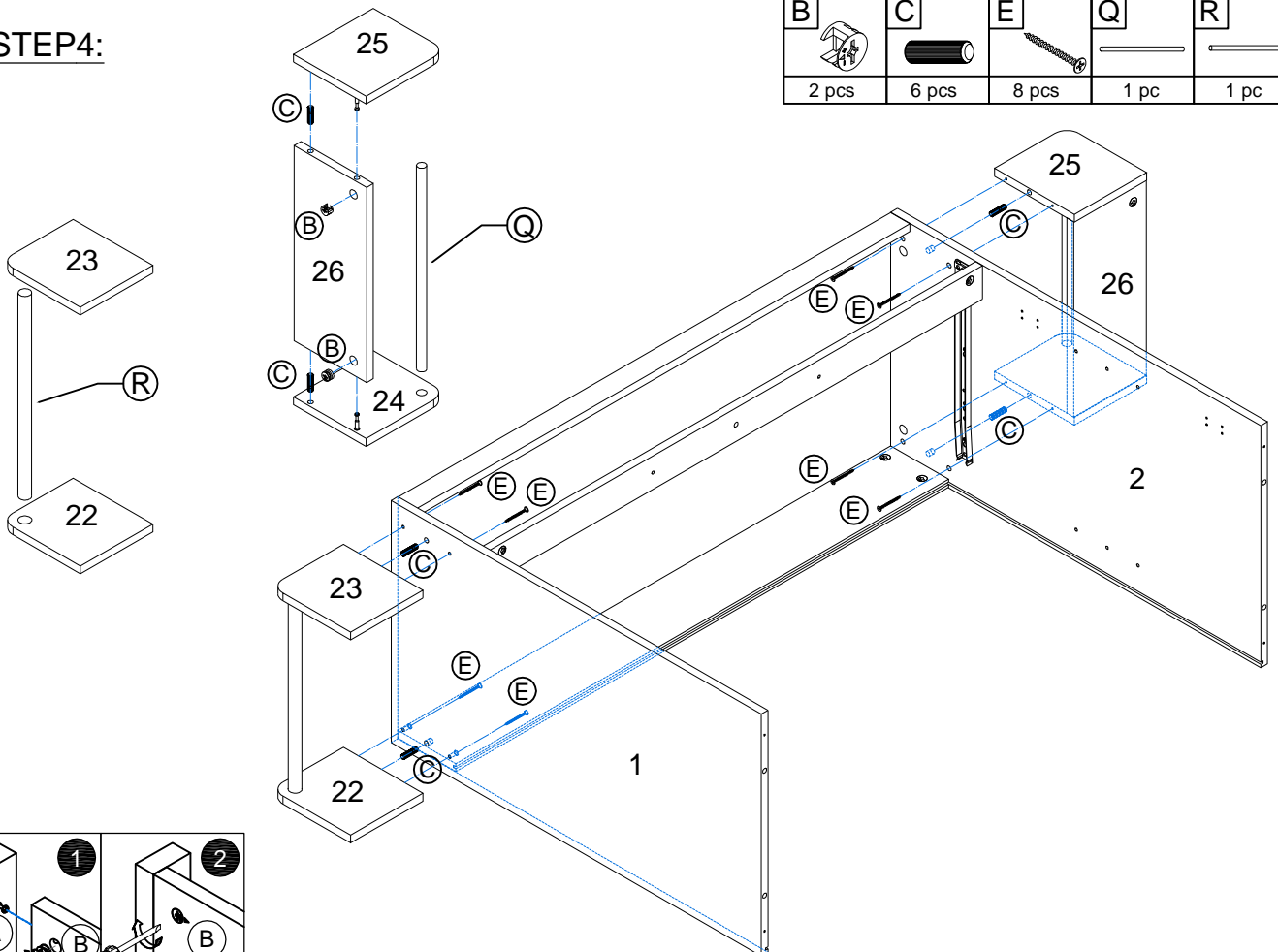



STEP7:

M

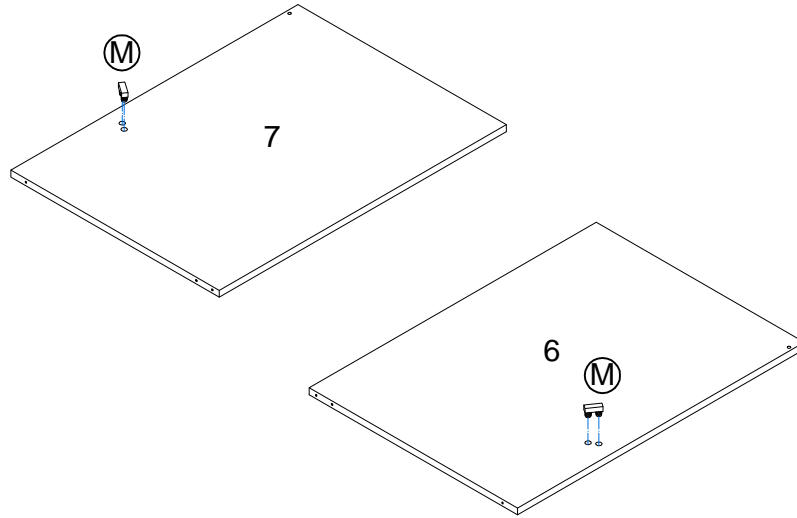
2 pcs

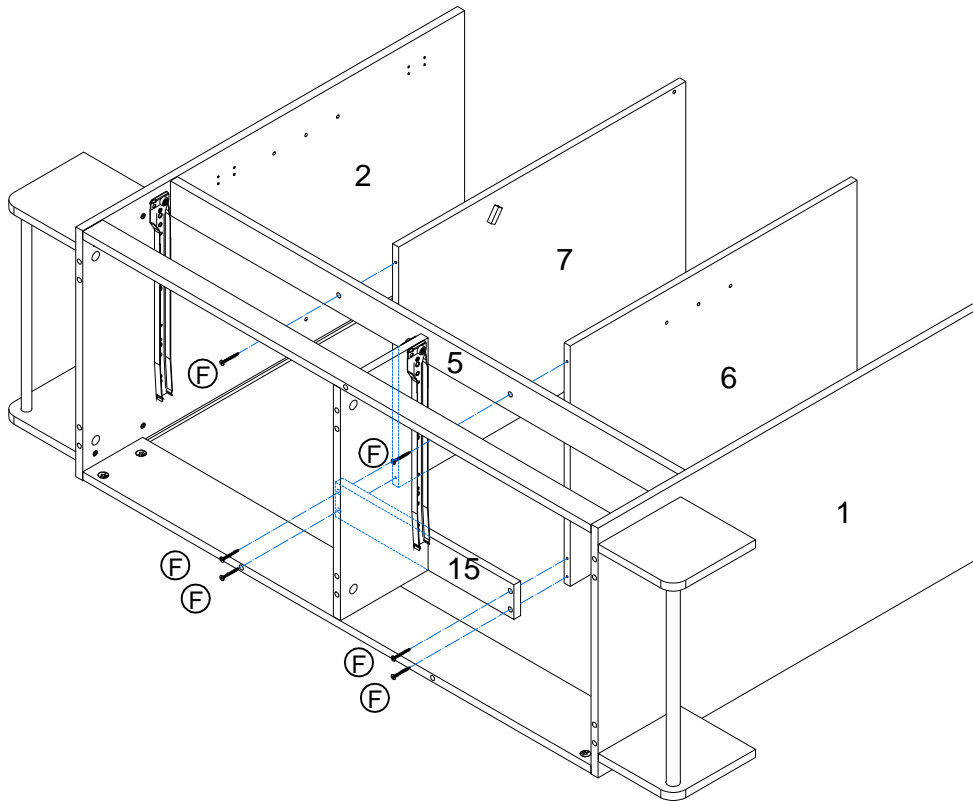

STEP8:

F

6 pcs





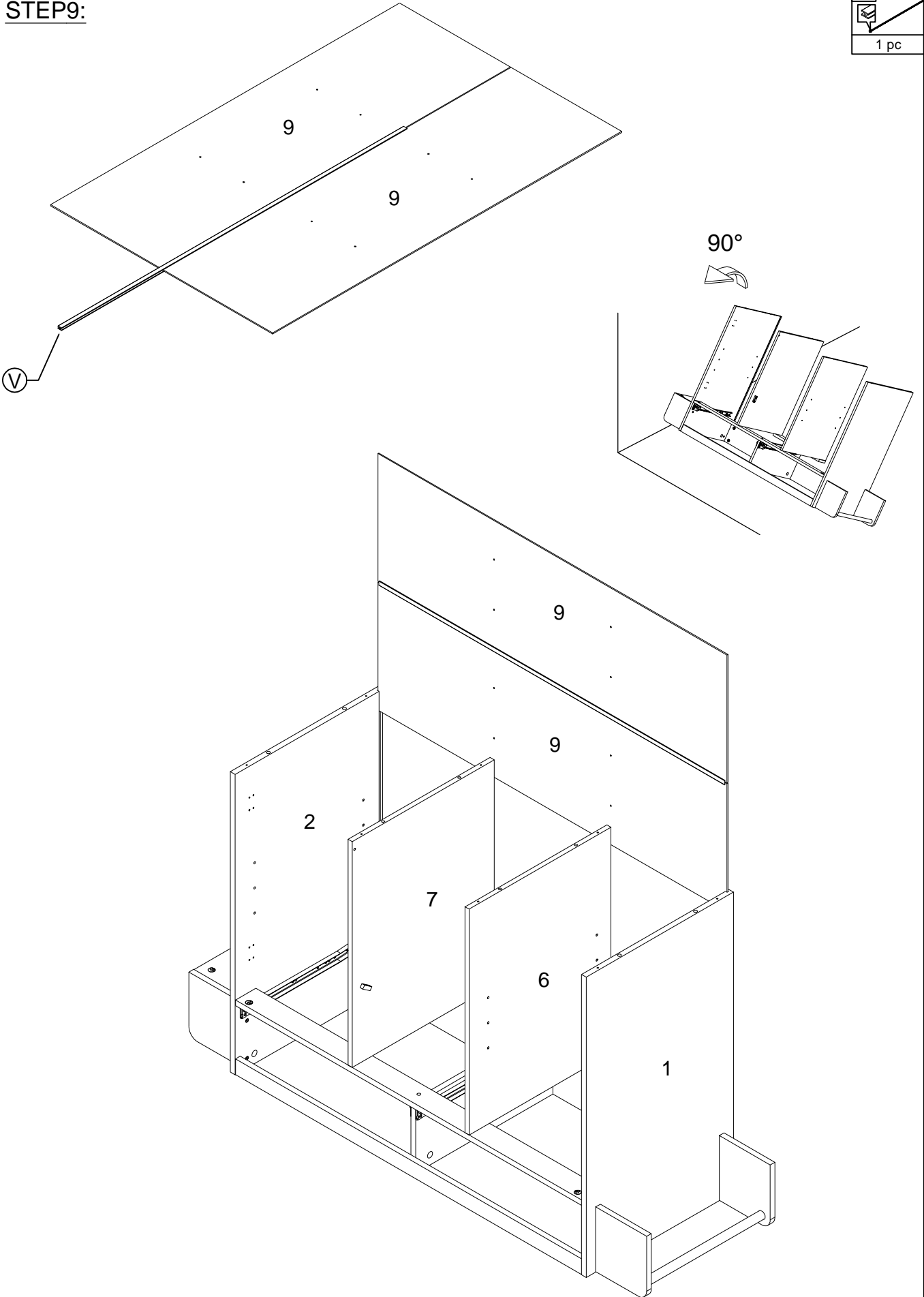

**STEP9:**

V  
1 pc



**STEP10:**

<b>B</b>	<b>D</b>	<b>F</b>	<b>L</b>
			
4 pcs	4 pcs	8 pcs	2 pcs

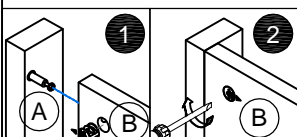
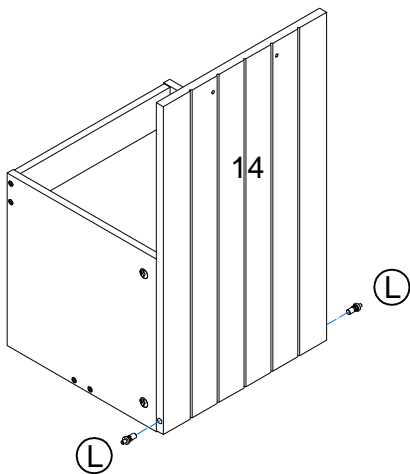
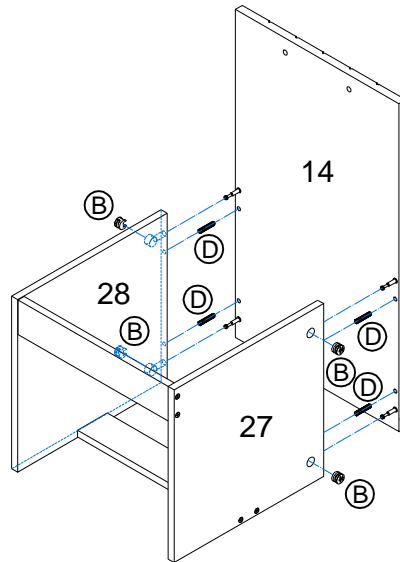
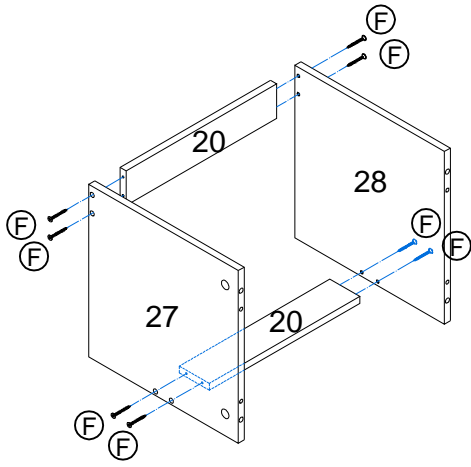

**STEP11:**

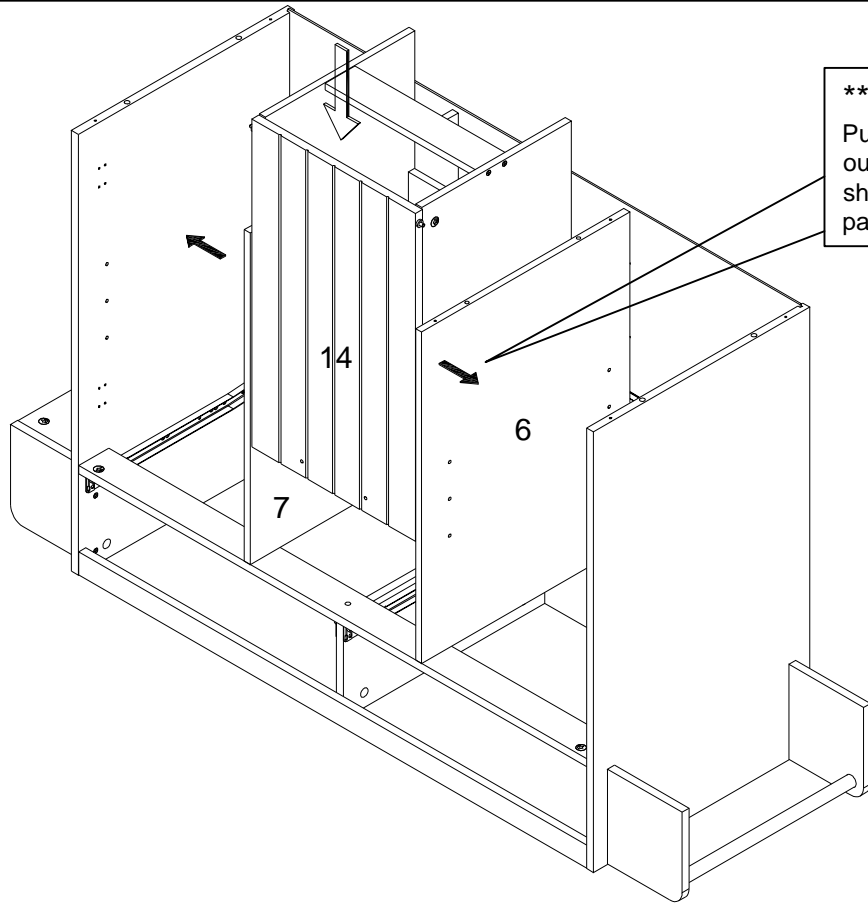



**\*\*Remark**

Push panel 6 and 7 outward and align shelf support with panel 14 side holes.

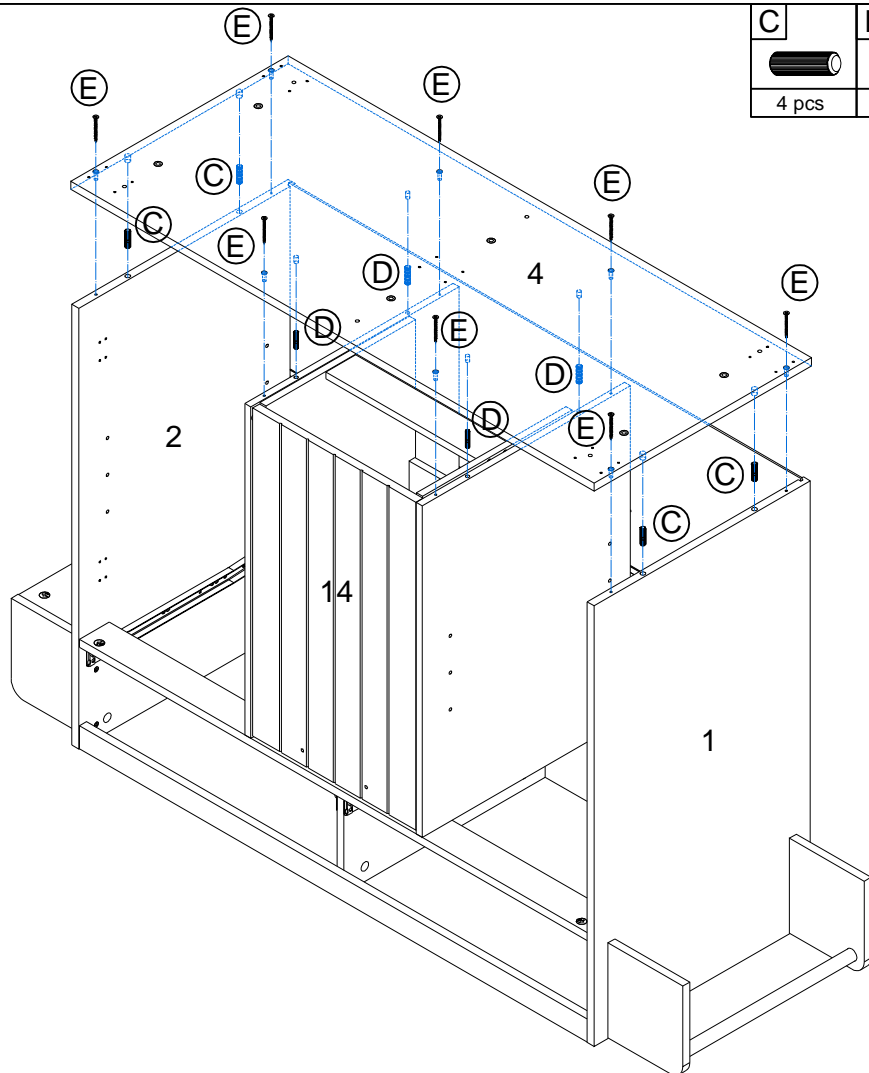
**STEP12:**



C	D	E
		
4 pcs	4 pcs	8 pcs

**STEP13:**

N1	N2	G	U	W
9 pcs	9 pcs	6 pcs	3 pcs	8 pcs

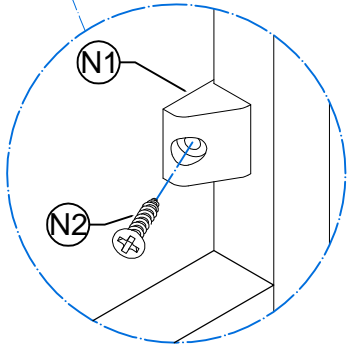
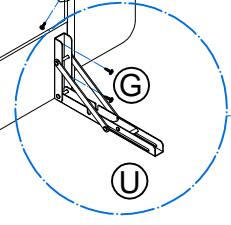
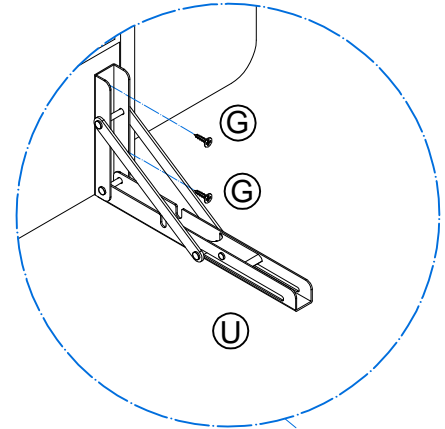
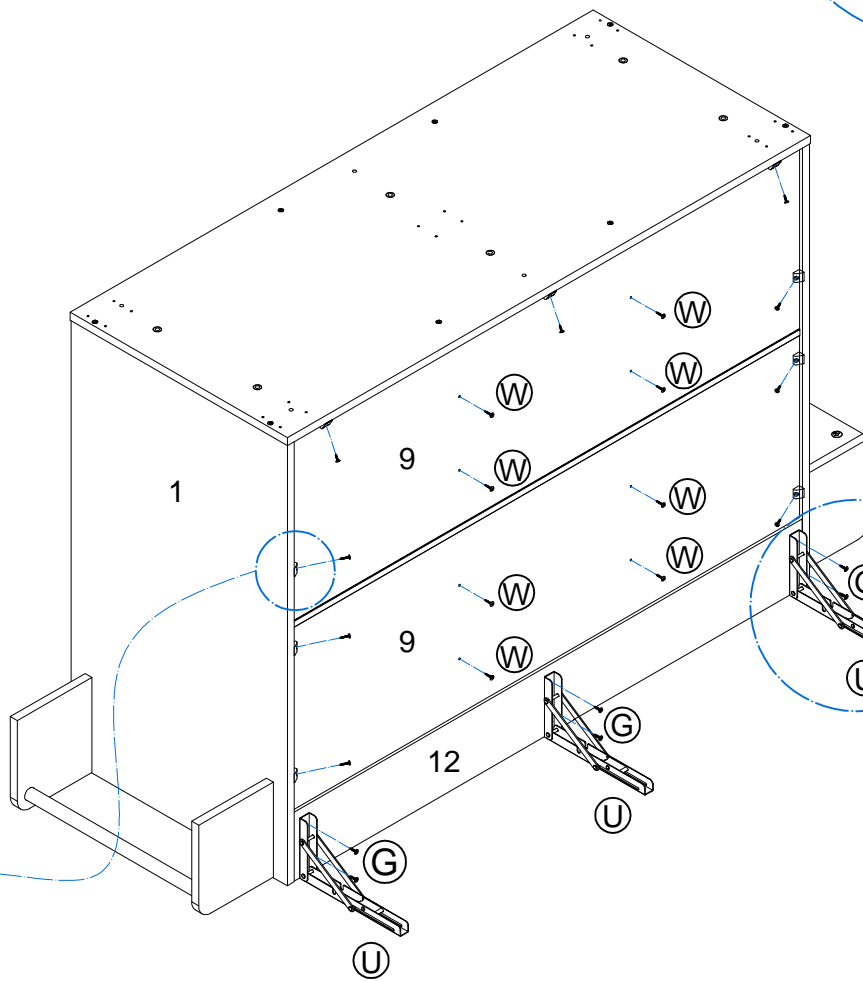

STEP14:

OPTION 1

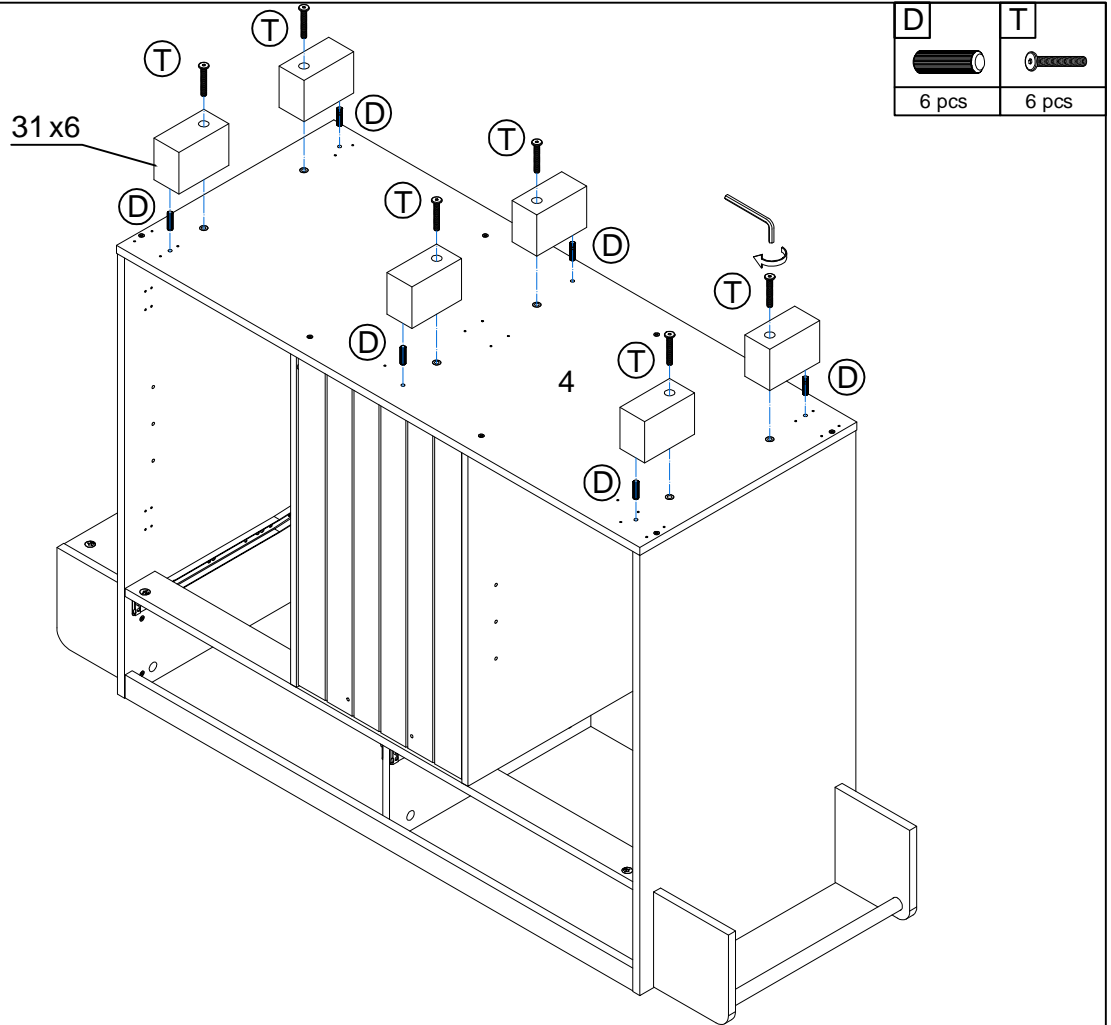

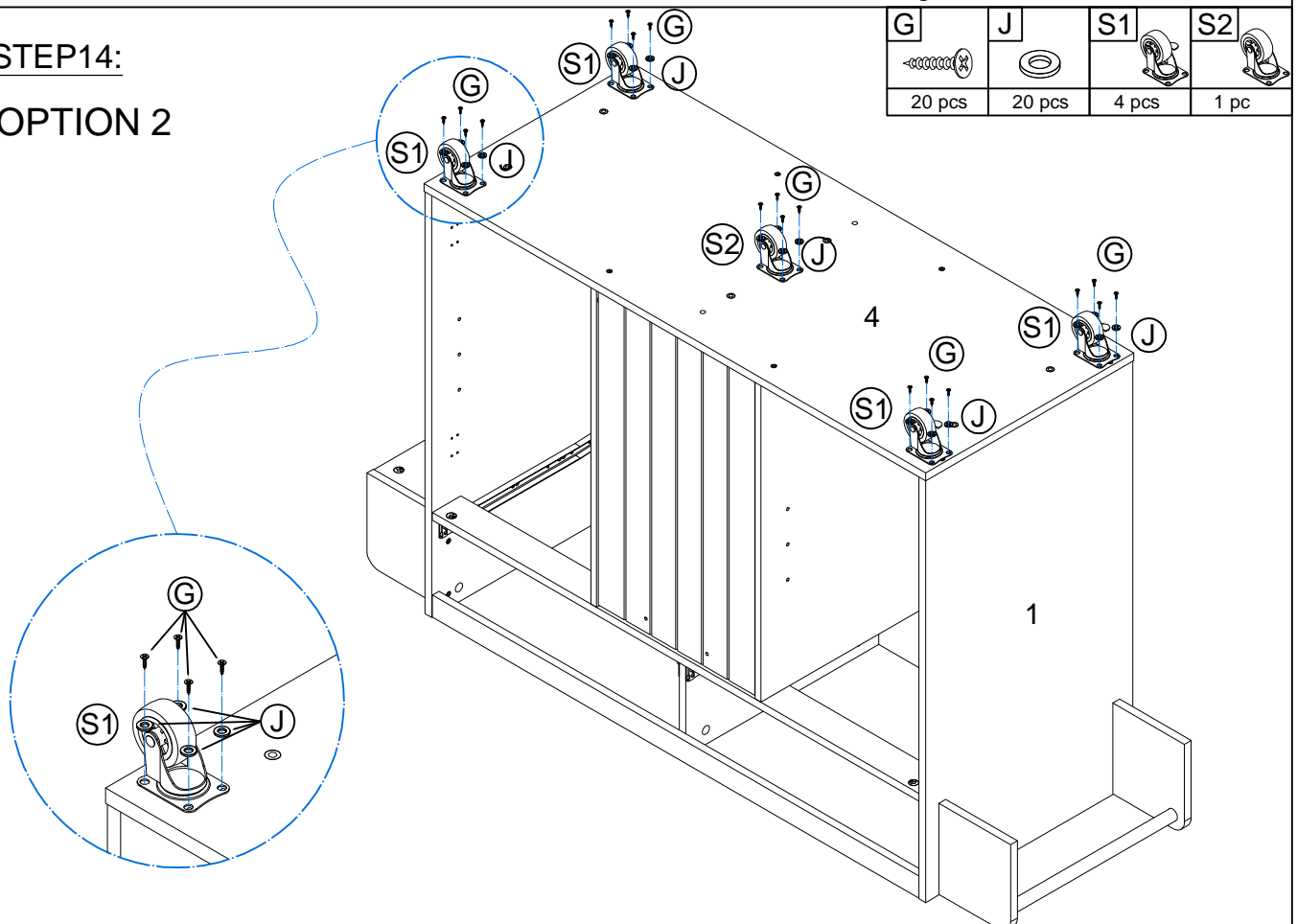

STEP14:

OPTION 2



**STEP15:**

<b>B</b> 	<b>C</b> 
7 pcs	8 pcs

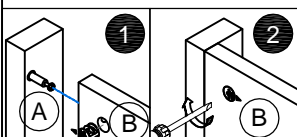
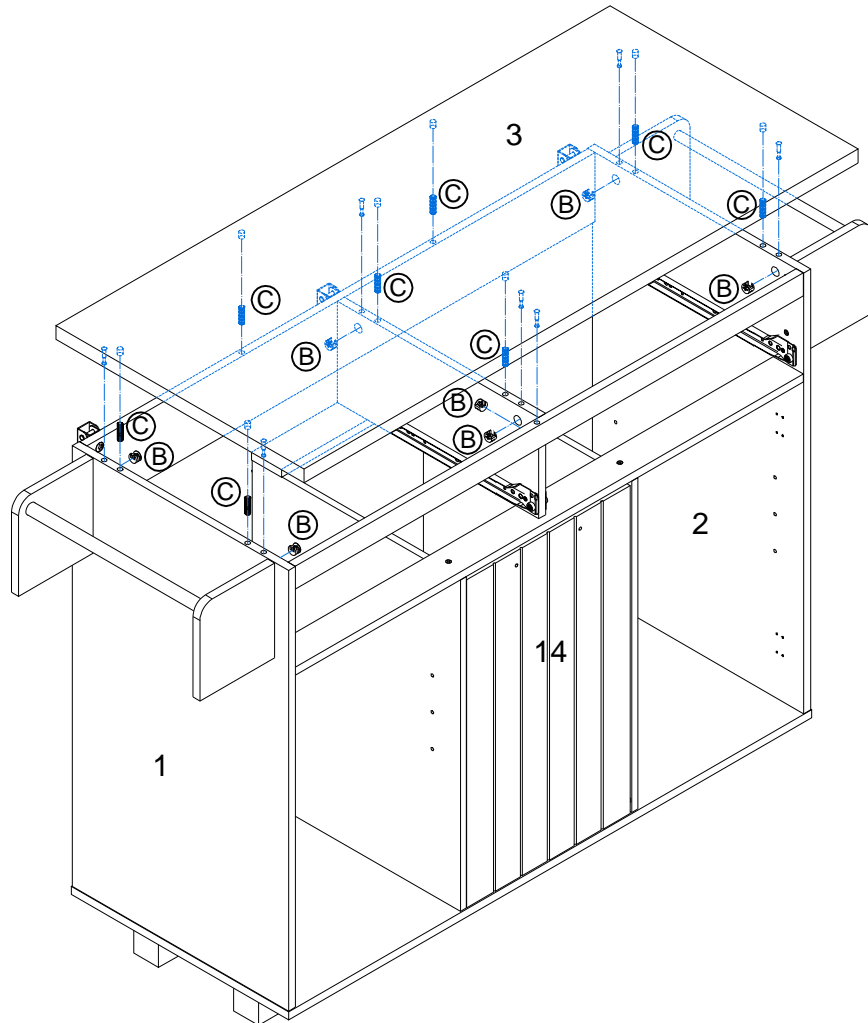
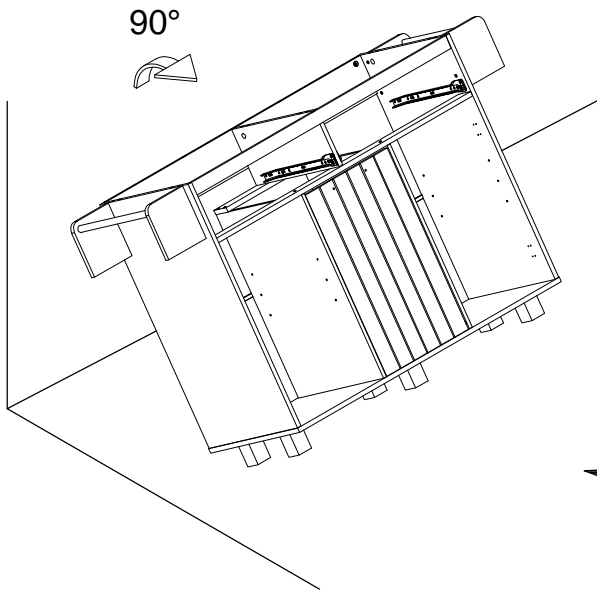

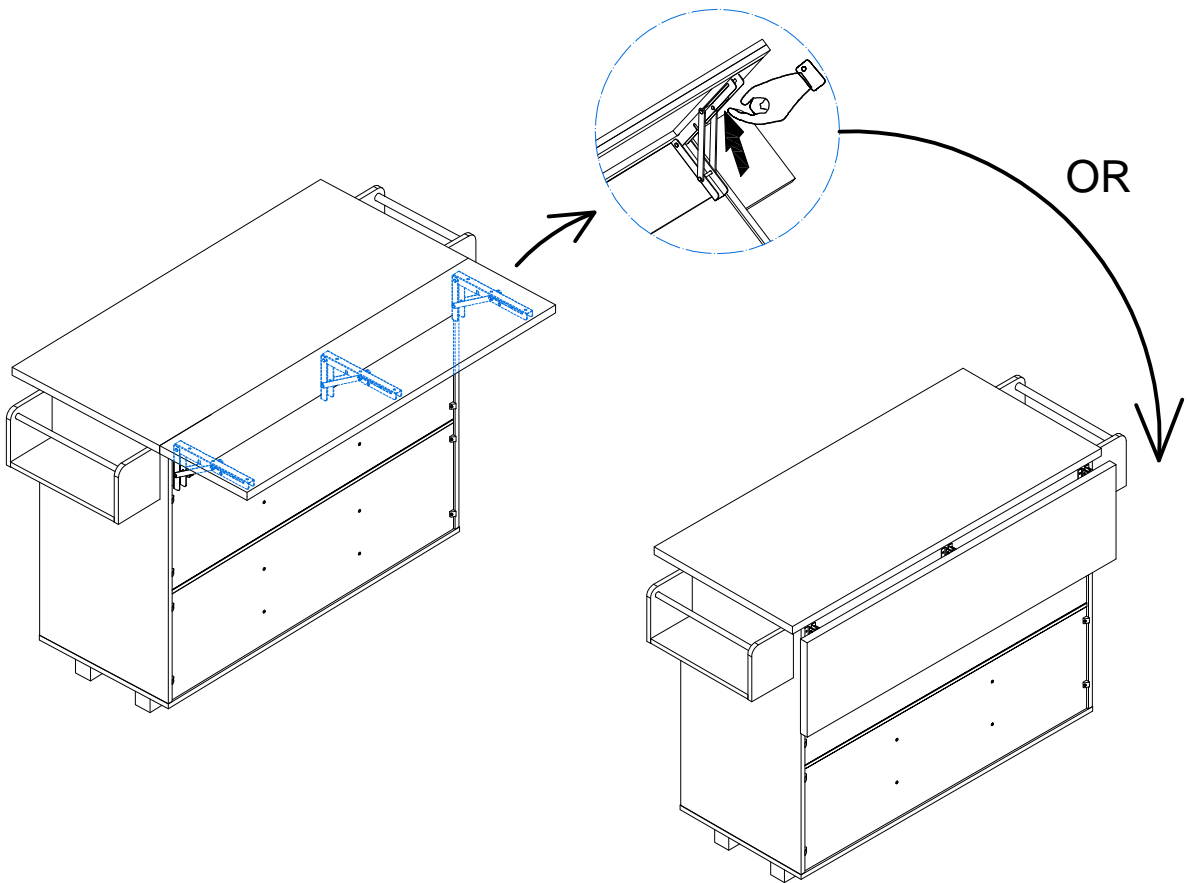
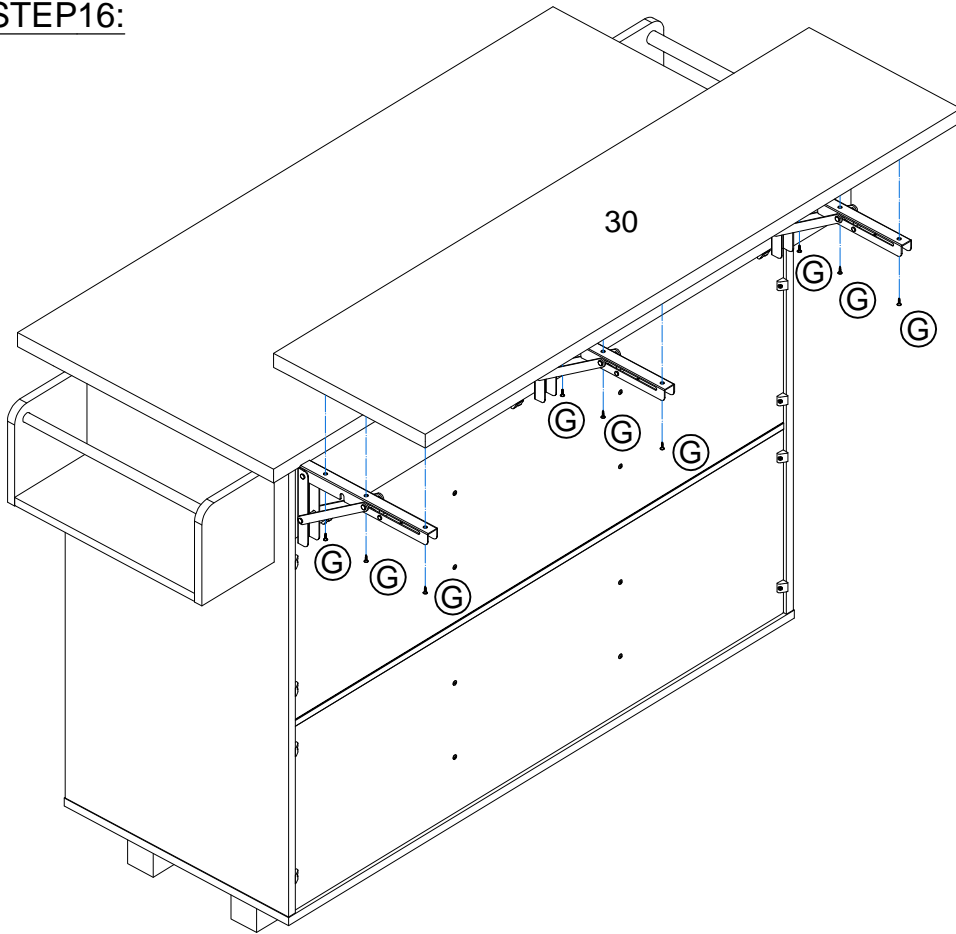

STEP16:

G  
-○○○○○○(X)  
9 pcs





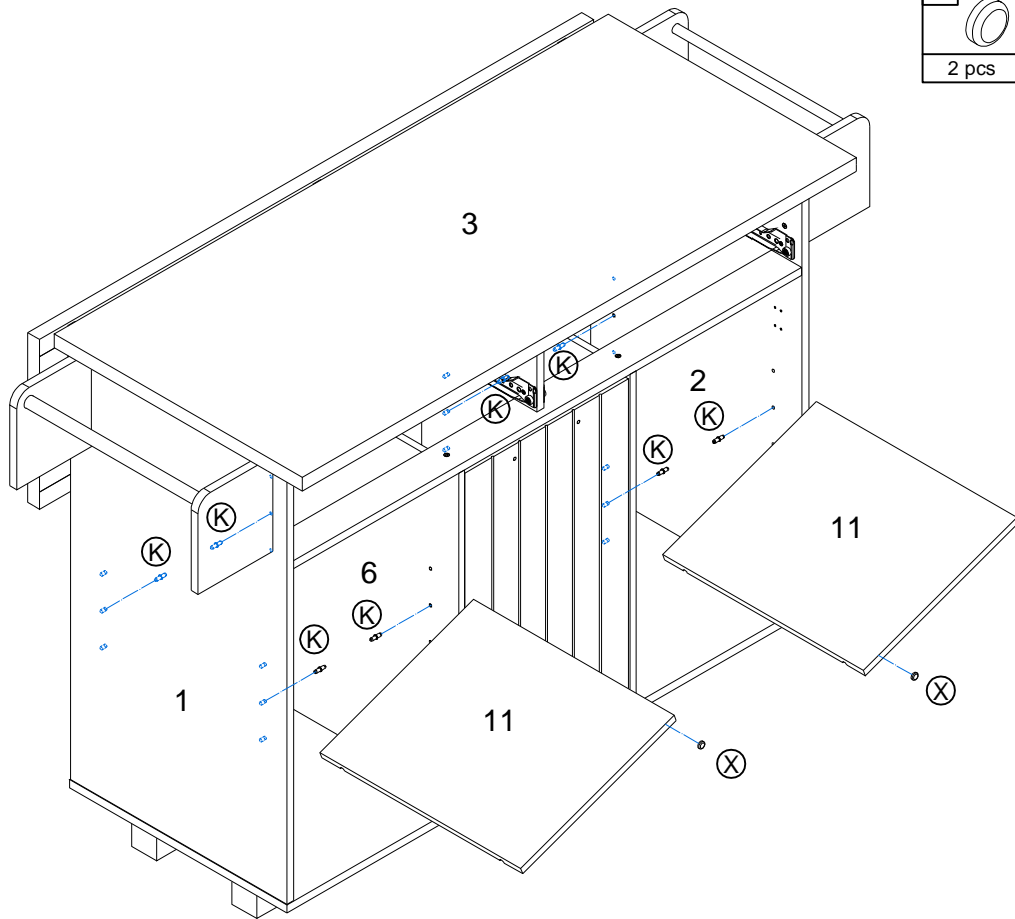

**STEP17:**

X		K	
	2 pcs		8 pcs



**STEP18:**



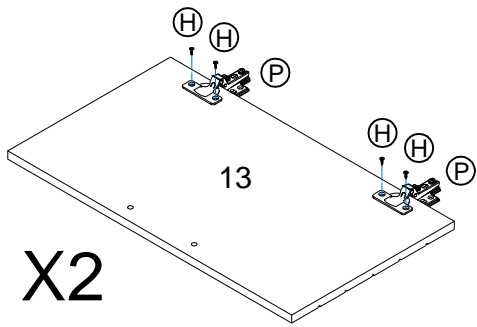



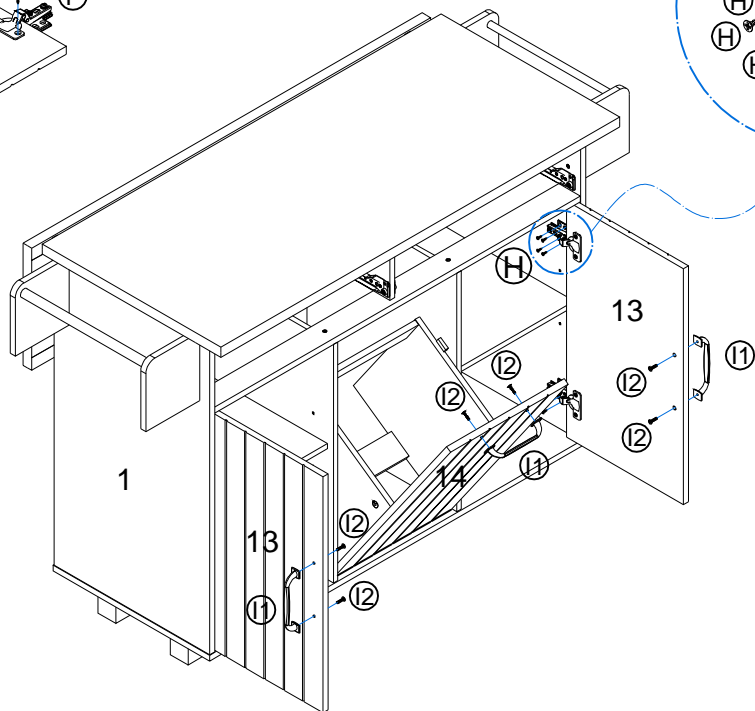

H		I1		I2		P	
	24 pcs		3 pcs		6 pcs		4 pcs



**X2**



**STEP19:**

<b>B</b> 	<b>D</b> 	<b>F</b> 	<b>H</b> 	<b>I1</b> 	<b>I2</b> 	<b>DR</b> 	<b>DL</b> 
4 pcs	4 pcs	8 pcs	8 pcs	2 pcs	4 pcs	2 pcs	2 pcs

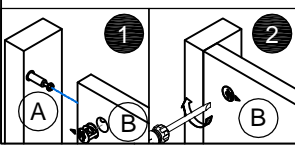
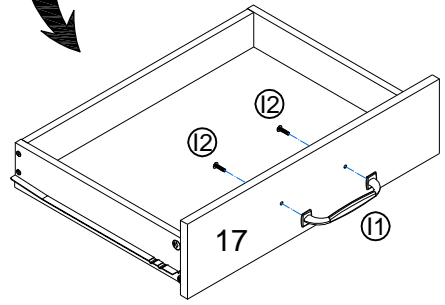
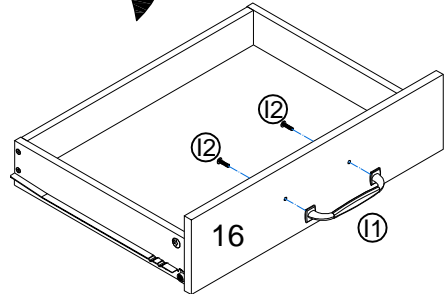
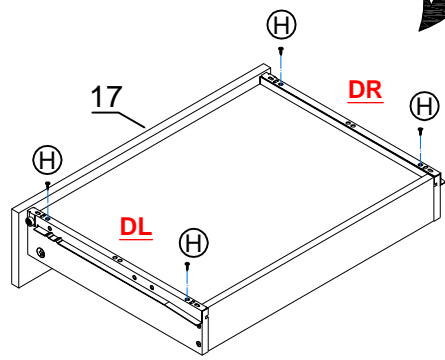
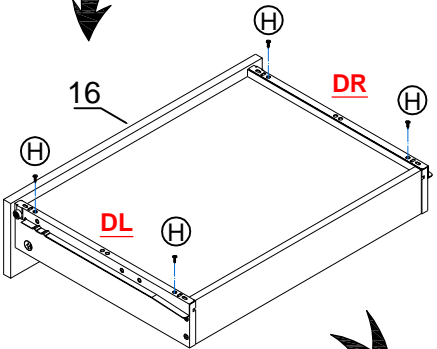
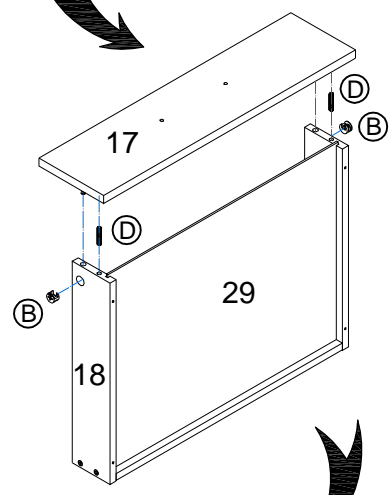
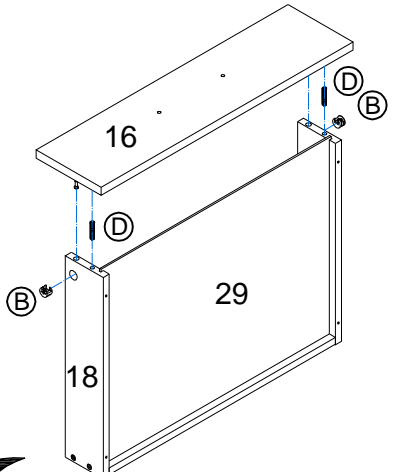
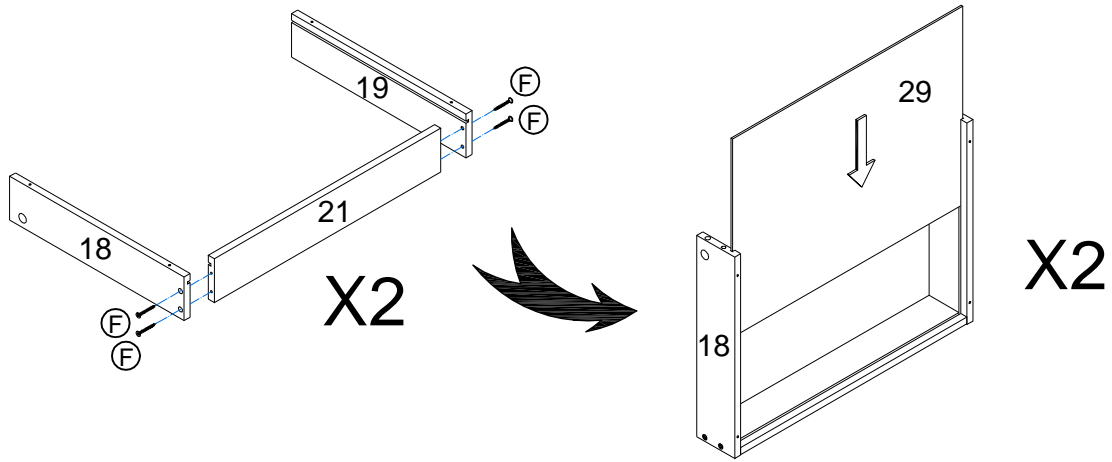

STEP20:

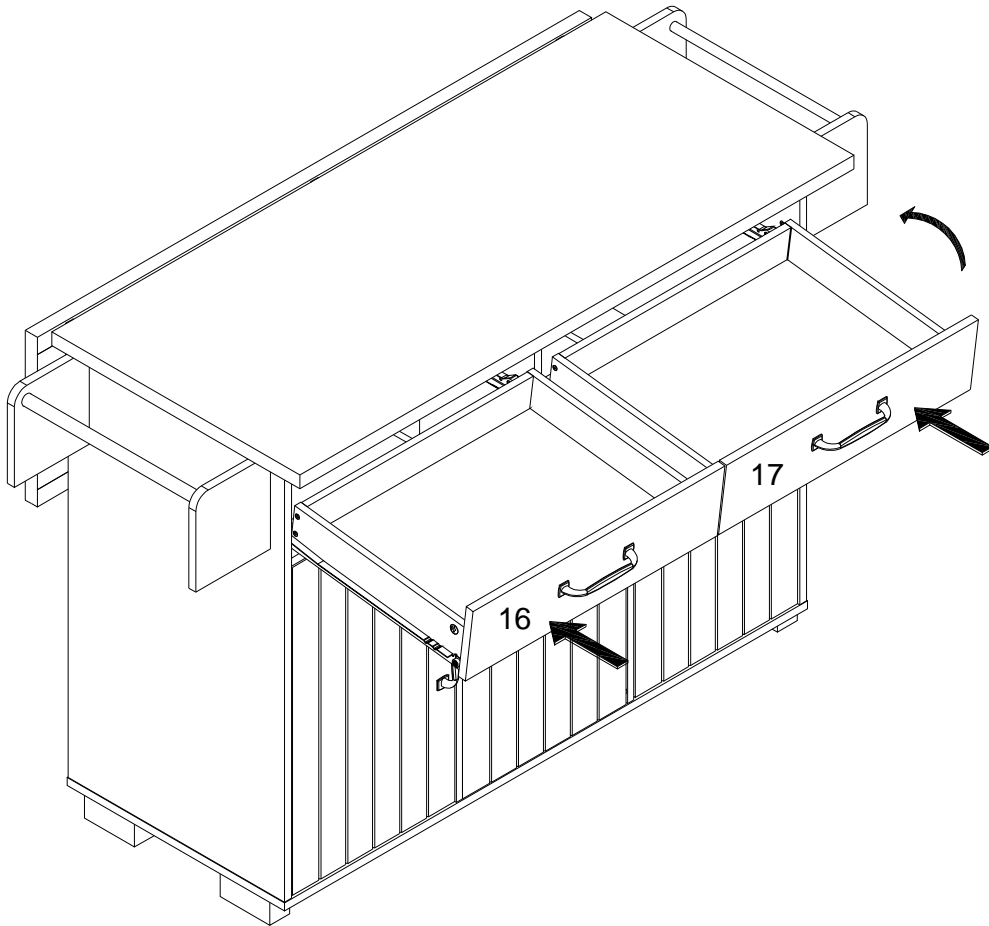
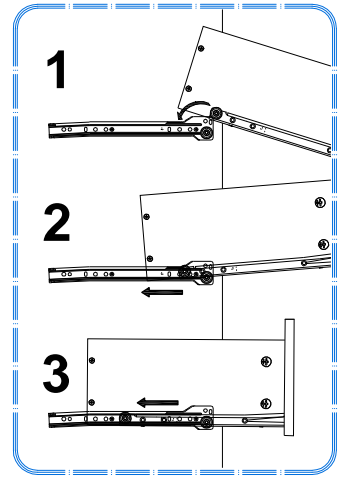

COMPLETE

