

Please check contents **before** assembly. If any items are missing or damaged, **do not take the unit back to the store.**

**COMPONENTS**

2 Preassembled Backs  
Right side Left side

1 Left Front Leg 26" Long    1 Right Front Leg 26" Long    4 Back Legs 26" Long

1 Left Front Leg 25" Long    1 Right Front Leg 25" Long    4 Leg Braces

2 Preassembled Seats

2 Cross Members

1 Table Top

2 Chair Arms 20" Long    2 Chair Arms 21 1/2" Long

**NOTE: Cracks or Checks in logs are part of the natural beauty of cedar logs and should not be considered defects.**

**HARDWARE**  
(Shown smaller than actual size)

8—1/4" x 3" Hex Washer Head Screws

28 — 2-1/2" Phillips Screws

**TOOLS REQUIRED**

Rubber Mallet or Block of Wood and Hammer

7/16" Wrench or Socket

#2 Phillips Screw-driver

Optional Power Screw Gun

Tape Measure & Pencil

**TIPS**

- A battery operated or electric drill will make assembly faster and easier.
- Use a good quality penetrating oil or wood deck sealer with a UV inhibitor. (Make sure product is intended for outdoor use.)
- If staining or finishing before assembling, tape off all dowel ends. (Finishes will cause the dowels to swell, making assembly difficult.)

Figure 1 & 2

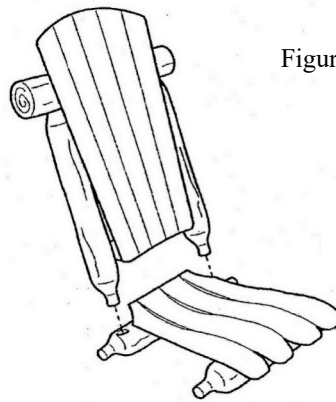

Tap uprights in or out until dowel drops into hole.

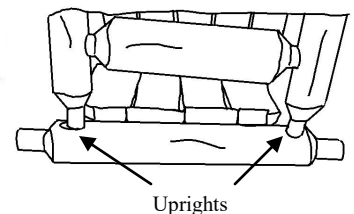

Uprights

**NOTE:**

- **Read all instructions before starting.**
- Sort, and verify all parts as shown in the components list above.
- To start hex washer head screws, hammer into wood about 1/2" then use wrench or socket to tighten.
- Do not completely tighten any screws until the unit is fully assembled and setting on a level surface.
- Use a rubber mallet (or a block of wood between the hammer and the unit) to drive doweled ends into holes as far as possible.

**STEP 1** Lay assembled seat on floor. Insert doweled end of uprights on assembled back into holes on the back seat rail, adjusting uprights in or out as needed to align properly. Do not tap on seat back with hammer. See Figure 1 and 2.

STEP 2 To keep the seat rail from splitting, use a rubber mallet or block of wood and hammer, lay the back on floor and drive the seat on by hitting on the bottom of the seat assembly. Figure 3.

Figure 3

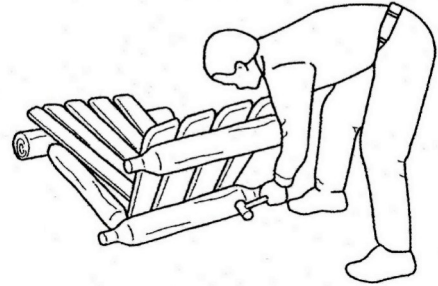

STEP 3 Sort legs and arms by length and hole locations. Make 2 outside leg sets and 2 inside leg sets by inserting doweled ends of the back leg into angled hole of front leg. The drilled holes on each leg should face the same direction as shown in figure 4. Put arms onto legs by inserting doweled ends of front legs into holes in arms.

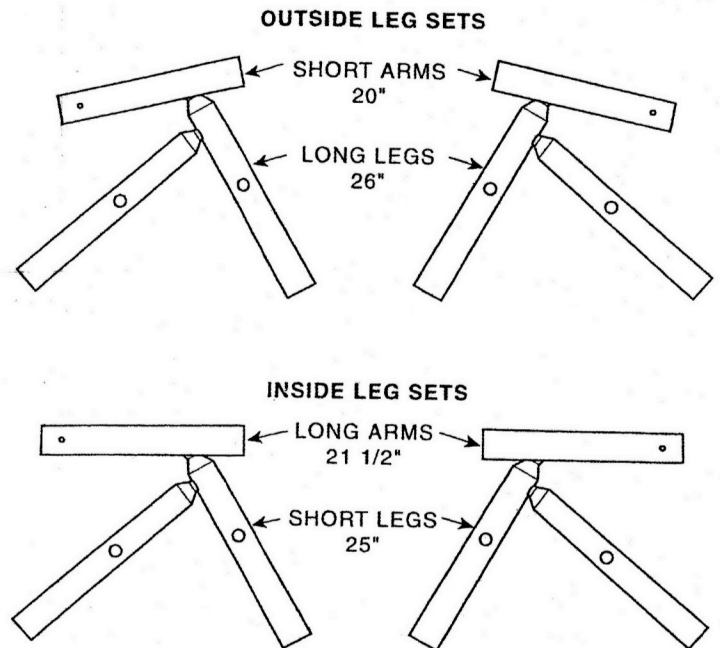

STEP 4

Assemble each chair unit with an outside leg set and an inside leg set.

Figure 4

**Note: The BACK assemblies have pre-drilled holes for inside leg sets and outside leg sets. Measure the distance to determine which side aligns with the correct leg set, as shown in figure 5.**

Lay back and seat assembly on its side and insert doweled ends of seat rails into holes on leg sets. Drive legs on as far as possible. Turn assembly over and repeat on other side. Repeat on other chair.

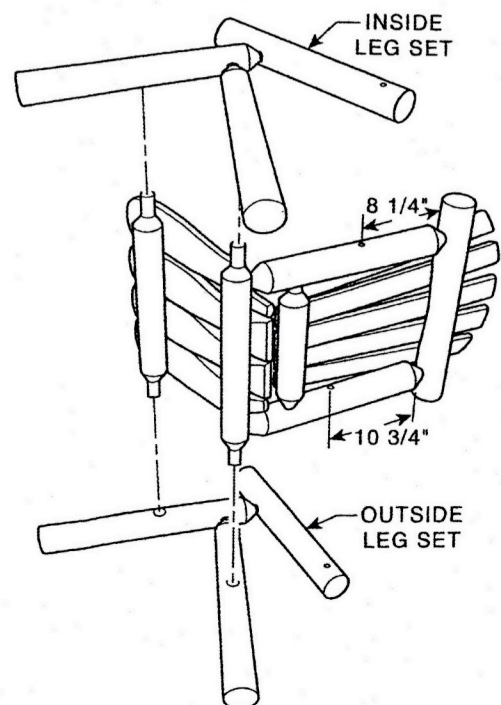

Figure 5

STEP 4 Set chairs in upright position and verify that you have assembled the chairs correctly. You should have 2 chairs each with an inside leg set, as shown in figure 6.

The inside leg set arms will be level. These will support the table.

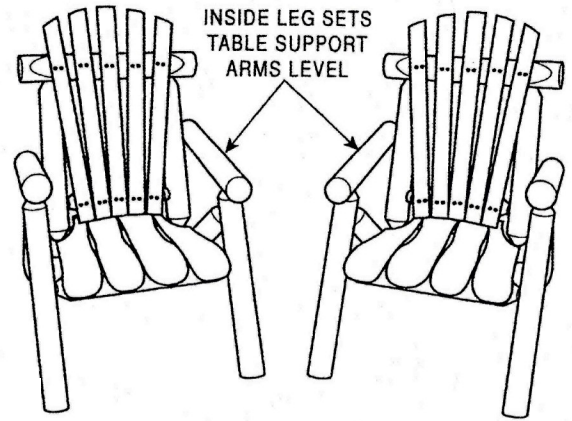

Figure 6

STEP 5 With chair in upright position on a level surface and with legs in proper position, bring arm in against upright and use a hammer to hit 5" hex washer head screw into predrilled hole in arm about 1/2". Tighten with a 7/16" wrench or socket. Secure seat and back doweled joints in place with screws perpendicular to the doweled ends as shown in figure 7.

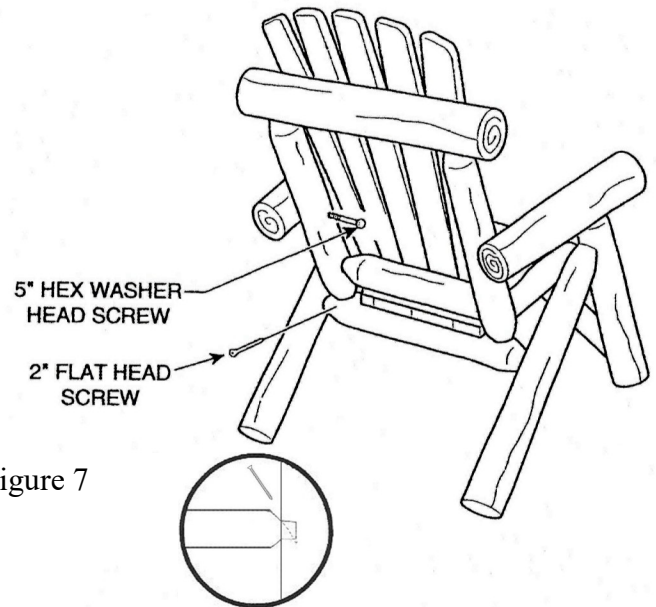
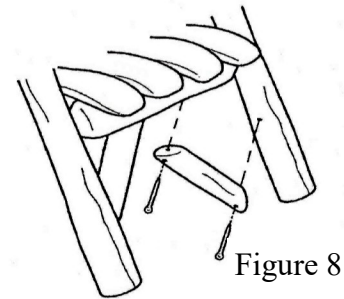

Figure 7

STEP 6 Tilt chair back and screw a brace on each side of front leg to chair bottom. Figure 8.



STEP 7 Set unit on a level surface and tighten down all hex washer head screws firmly to secure unit. Secure all doweled joints in place with screws perpendicular to the doweled ends as shown in figure 7.

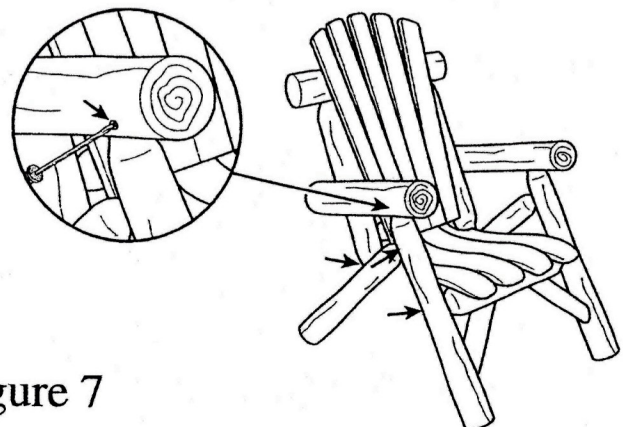

figure 7

STEP 8 Position chairs so that the inside leg sets (table support arms) are next to each other. Adjust chair position until table top will set between the chairs and flush to the front edge of the arms. Attach the table to the chairs with four 3" hex washer head screws through predrilled holes in table cross-members. Figure 9.

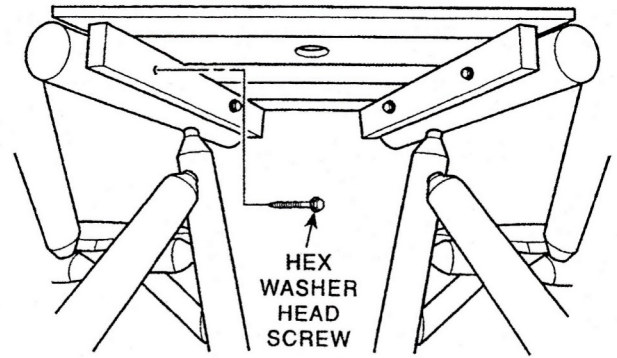

Figure 9

STEP 9 Attach the chair cross-member using two 3" hex washer head screws. Align the crossmember from 9" to 12" from the bottom of each inside back leg so that the hex washer head screws are centered on each leg. See figure 10

Repeat this process for the short crossmember. Center between the two front legs beneath the table. Secure with hex washer head screws.

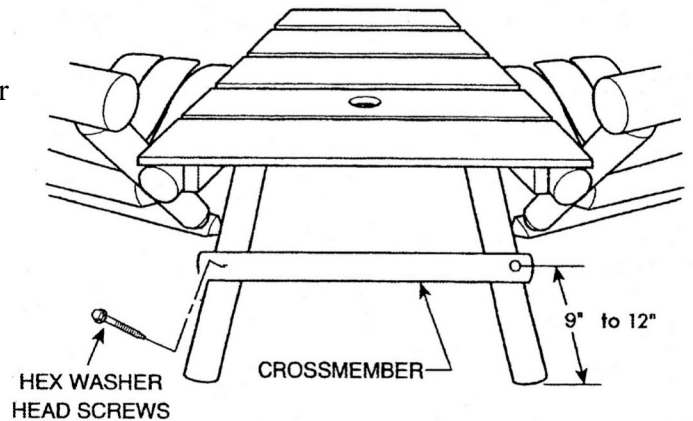

figure 10

Check all nuts and bolts for tightness before and during each usage season.

