

Instructions for Audrey Trestle Extension Tables

Unpack the table onto a soft level surface and identify the listed items.

Hardware included: 4mm Allen wrench (1)

Audrey Extension Dining Tables:

- 42" x 72" Extension Table
- 42" x 66" Extension Table
- 38" x 72" Extension Table
- 38" x 66" Extension Table
- 38" x 60" Extension Table

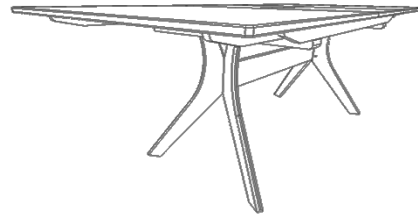

Tools required | Philips head screw driver

Step 1: Remove the shipping blocks

Lay the *table top* face down on a soft level surface. Use a Philips head screw driver to remove blocks under the *table top* by detaching all the *flat head screws* from the *shipping blocks* (**Figure 1**).

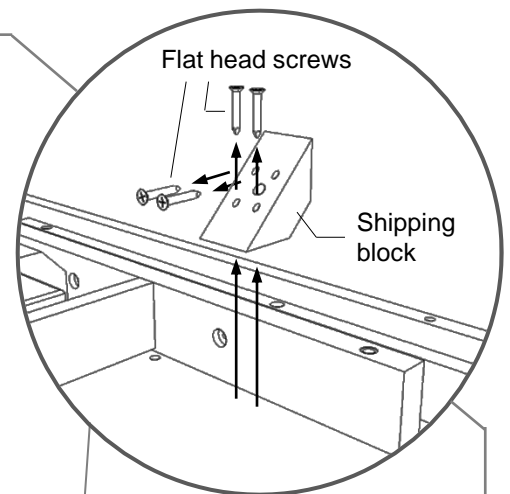

Remove the shipping blocks

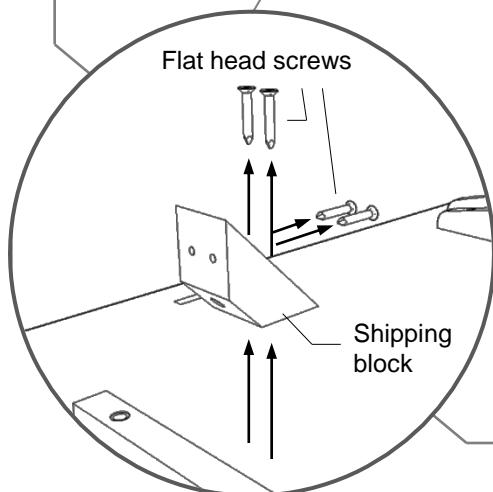
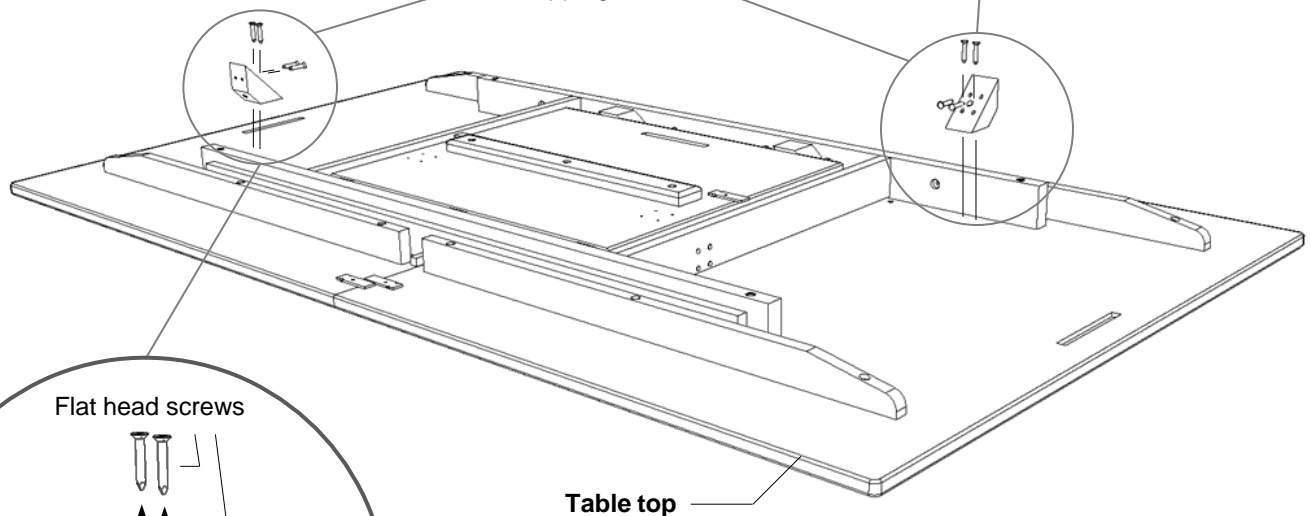

Figure 1. Remove the *shipping blocks* from the *table top*



When
in use

How to lock and unlock the table top

To lock the top, push down the small black handle in the middle of the slide arm. To unlock the top, simply push the handle up on both sides. *Lock-up handle* located in the middle of the slide arm (**Figure 2**).

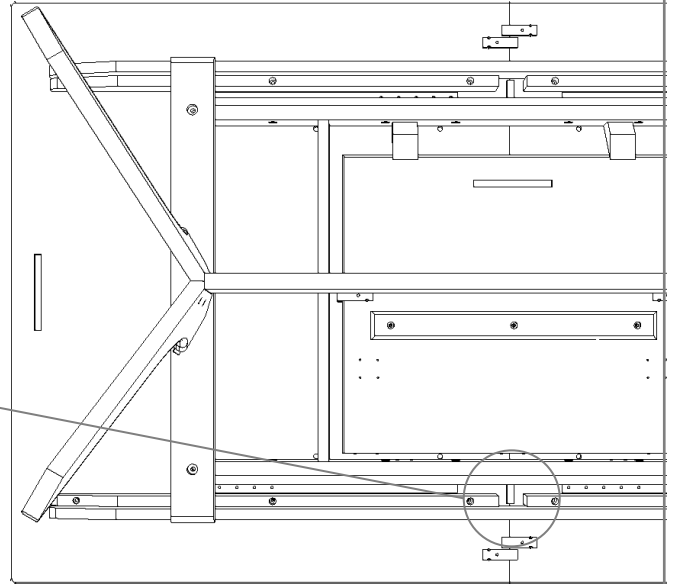

▷ **Figure 2.** Lockup handle location

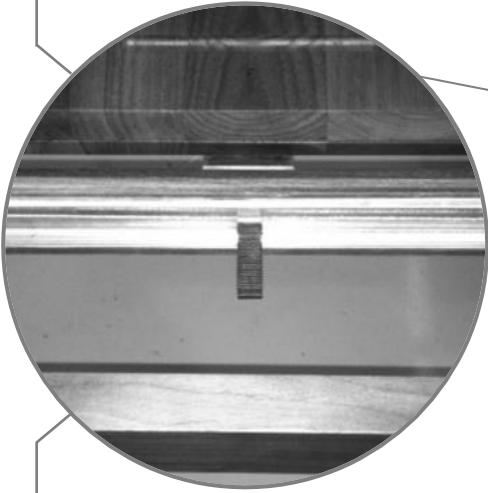

When
in use

How to open and close table top

Open the table top

- ▶ Unlock the table (if locked).
- ▶ Pull out the table top from either end.
- ▶ Unfold the leaf.
- ▶ Push the top from either end towards the center.
- ▶ Lock the table (optional).

Scan to watch
easystow operation video



Close the table top

- ▶ Unlock the table (if locked).
- ▶ Pull out the table top from either end.
- ▶ Lift up the leaf and gently fold it into the table.
- ▶ Close the top by pushing it to the center from either end.
- ▶ Lock the table (optional).



**Note**

Extension table re-alignment tips

Your table was checked for proper alignment before it was packed for shipment. During shipment this alignment may have been impacted. If this occurred it may require some adjustment.

Tips: Re-aligning extension table (Figure 3)

1. When the leaf is in the open position loosen the bolts attaching the table to the base.
2. Align the leaf and table ends.
3. Tighten the bolts working in a "X" pattern.

If the above method proves insufficient the table tops have moved on the slides themselves. To correct this (Figure 4):

1. With the leaf is in the open position loosen all the screws attaching the metal slides to the table tops.
2. Align the leaf and table ends.
3. Tighten the screws.

1. Loosen the bolts before re-alignment.
3. Tighten the bolts after alignment.

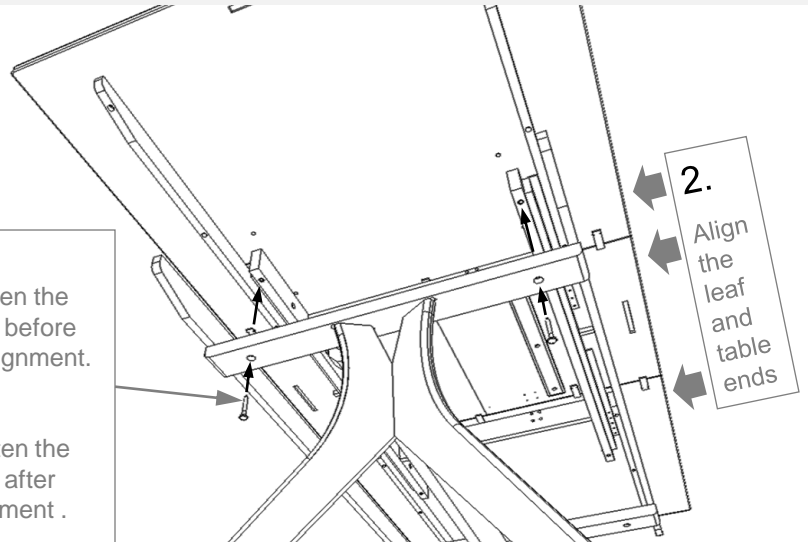
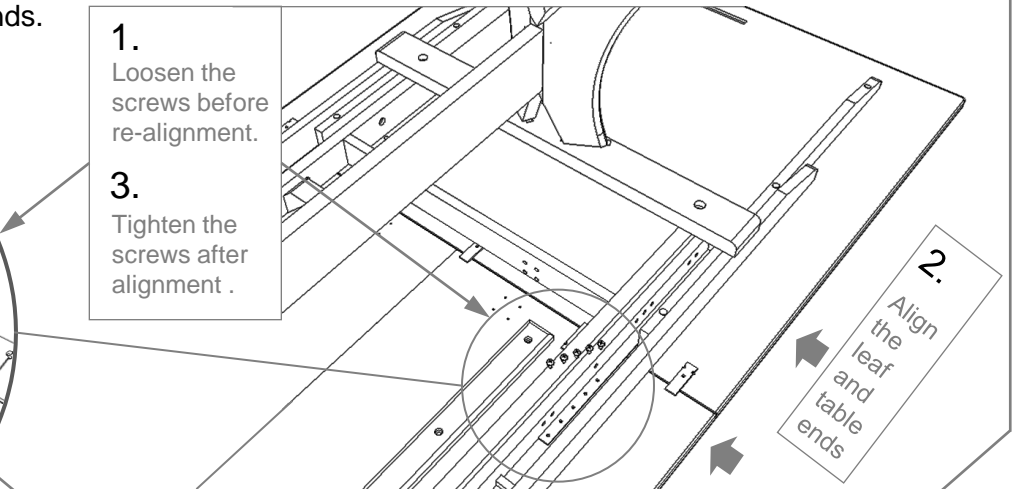
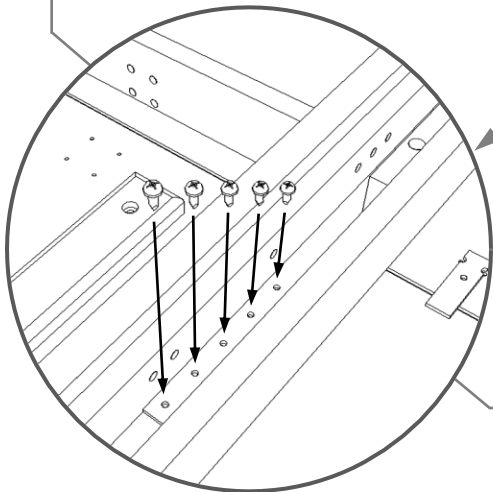

Figure 3. initial re-alignment

Figure 4. further re-alignment

1. Loosen the screws before re-alignment.
3. Tighten the screws after alignment.

**Attention**

After the table is fully assembled, DO NOT try to pick up the table from the ends – especially if the table is fully extended. Should the table need to be relocated, close the table and carefully lift the table in the middle area where the two tops meet.

Care Instructions

To care for and preserve the finish on your new Copeland Furniture piece, please keep the following recommendations in mind.

- While our furniture has been finished with a durable top coat, the surface may be sensitive to dents and abrasions during the first 30 days in your home.
- Treat the surface finish gently so it does not dent or chip. Tape or stickers should not be put on the finish.
- For general care use a soft cloth to dust the furniture.
- Use damp cloth with a mild soap to clean-up spills or dirt. Dry the surface thoroughly.
- Please do not use any polishes, waxes or solvents to clean the surface of the furniture. This holds true for new Copeland Furniture pieces as well as items you may already have in your home.
- Please do not place any candles directly on the surface of your furniture. The perfumes and dyes in the candles may penetrate the finish.
- Beds must be disassembled before moving to avoid damage. Never attempt to move the bed while it is assembled.

Special Care Instructions for Cherry Furniture

Please read the following if you have purchased a Copeland product in cherry. Furniture that has been crafted from cherry wood becomes darker with age. The change in color, from a reddish tan to a reddish brown, is most noticeable during the first six months of ownership. It is important to understand that exposure to light accelerates the natural oxidization process. An object left on a cherry wood surface for an extended period of time may retard the aging process in a limited area. Simply remove the object and, over time, the surface will attain a uniform reddish brown color.

