

ASSEMBLY INSTRUCTIONS

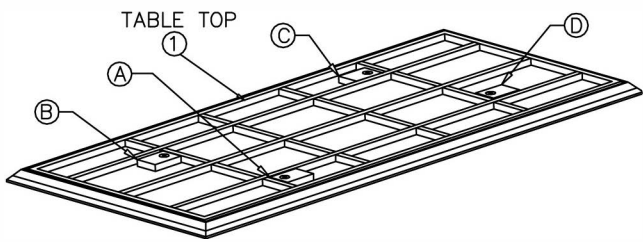

STEP-1

OPEN THE PACKING AND PLACE THE TABLE TOP SIDE DOWN ON SMOOTH SURFACE (CARPET)

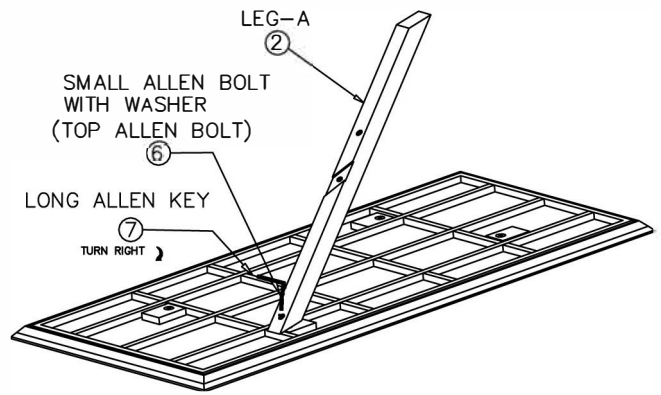

STEP-2

PLACE THE LEG-A ON A MARKED ON THE TABLE
USE THE LONG ALLEN KEY TO HALF SCREW TIGHT TOP ALLEN BOLT
 NOTE:- NOT FULLY TIGHT

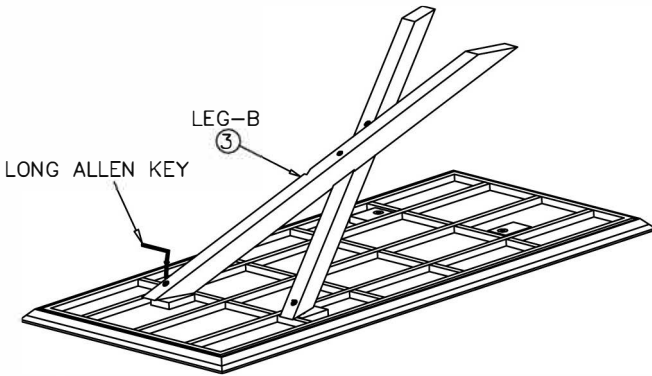

STEP-3

PLACE THE LEG-B ON B MARKED ON THE TABLE
USE THE LONG ALLEN KEY TO HALF SCREW TIGHT TOP ALLEN BOLT
 NOTE:- NOT FULLY TIGHT

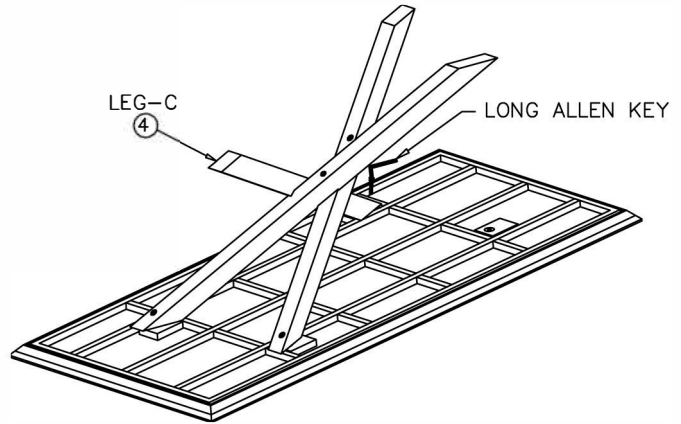

STEP-4

PLACE THE LEG-C ON C MARKED ON THE TABLE
USE THE LONG ALLEN KEY TO HALF SCREW TIGHT TOP ALLEN BOLT
 NOTE:- NOT FULLY TIGHT

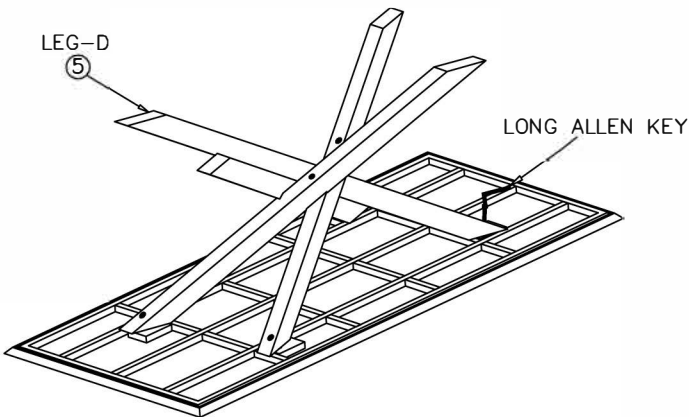

STEP-5

PLACE THE LEG-D ON D MARKED ON THE TABLE
MATCH ALL LEG WITH LEG SCREW HOLES &
USE THE LONG ALLEN KEY TO HALF SCREW TIGHT TOP ALLEN BOLT

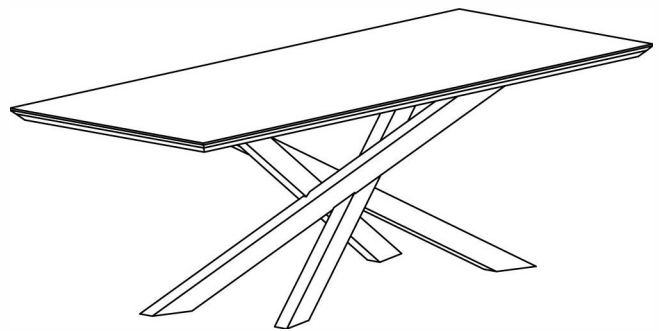

STEP-7

FINAL ASSEMBLY

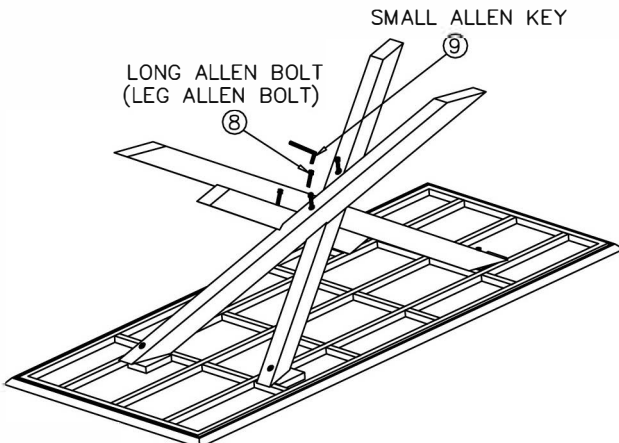

STEP-6

USE THE SMALL ALLEN KEY TO FULL SCREW TIGHT ALL LEG ALLEN BOLTS
USE THE LONG ALLEN KEY TO FULL SCREW TIGHT ALL TOP ALLEN BOLTS
 NOTE:-FULLY SCREW TIGHT

ITEM NO.	DESCRIPTION	QTY.
1	TABLE TOP	01
2	LEG-A	01
3	LEG-B	01
4	LEG-C	01
5	LEG-D	01
6	SMALL ALLEN BOLT W/WASHER(TOP ALLEN BOLT)	04
7	LONG ALLEN KEY	01
8	LONG ALLEN BOLT W/WASHER(LEG ALLEN BOLT)	04
9	SMALL ALLEN KEY	01

ASSEMBLY INSTRUCTIONS