

# Writing Desk

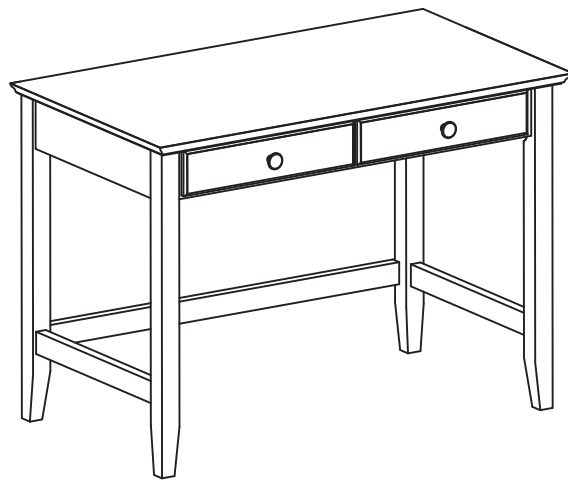

Congratulations! You have purchased a stylish piece  
We strive to provide fine furniture products, built with quality materials  
and hand finished details. Please carefully follow the assembly instructions  
to ensure your furniture is assembled correctly to provide long lasting  
enjoyment.

Products are warranted against defects in material and workmanship for  
a period of 90 days beginning from the date of sale.

**Should you experience any damaged, defective, or missing parts, or need  
help with assembly, please call us directly before contacting the retailer.**  
Please see included Care and Maintenance Instructions for this Product.

# Care and Maintenance Instructions

## Keeping Your Furniture Beautiful

Quality furniture is a significant investment expected to last for generations. To maintain its beauty and help it last, furniture needs the right care. No finish is totally indestructible. But with regular care, the finish will last much longer, providing years of enjoyment to you.

## Tips to Protect and Care for Your Furniture

1. Avoid placing your furniture in direct sunlight, as sunlight causes fading.
2. Avoid extreme changes in temperature by arranging furniture away from radiators, heat and air vents and air conditioning units.
3. Avoid placing plastic or rubber materials (lamp bases, notebooks, placemats, etc.) on your furniture, as certain plastics contain ingredients that may damage the finish.
4. Periodically rotate accessories on furniture so they do not sit in the same spot all the time.
5. Use pads, cloth or felt to protect the furniture surface from plastic, rubber, hot dishes, beverages, bookends, flowerpots and vases.
6. Clean up spills immediately. Use a blotting rather than a wiping action. Water left over a long period of time will cause white spots in the finish. Alcohol, perfume, after-shave and medications can cause severe finish damage.
7. Use a protective pad when writing on the furniture surface.
8. Lift and place objects rather than dragging them across the furniture surface.
9. Avoid placing furniture directly under windows.

**Wood Furniture Care:** We recommend dusting frequently with a clean, soft, dry, lint-free cloth. Clean the surface by rubbing in the direction of the grain. We recommend polishing your furniture approximately every six months, using a clean, soft, lint-free cloth and rubbing the polish in the direction of the grain. Guardsman furniture polish or any furniture polish that doesn't contain silicone is recommended.

**Leather Furniture Care:** Wipe spills immediately with clean cloth or sponge. For spots or stains and daily cleaning, clean with mild non-detergent soap. Rinse well, gently wipe off, and allow to air dry. Cleaning Butter, Oil or Grease from Leather: Wipe leather with a clean cloth, and leave alone. The oil will be absorbed by the leather. DO NOT APPLY WATER. Also, do not use saddle soap, cleaning solvents, furniture polish, oils, varnish, abrasive cleaners, ammonia or any other type of chemical solution.

**Granite Furniture Care:** Our granite is not sealed, so you may want to apply an over-the-counter sealant, which will provide a small amount of surface protection, but we still recommend cleaning spills promptly. Use a slightly damp cloth to clean as needed. Wipe dry. We also do not recommend using abrasive cleaners, chemical solvents, strong detergents, cleaners with bleach, and furniture polish. Be sure to use trivets, coasters, placemats, and adhesive felt pads to help prevent scratches.

**Wicker Furniture Care:** Regular cleaning is recommended for wicker, as it generally cannot endure harsh or abrasive treatments. This also minimizes mildew buildup. To remove dirt and debris, vacuum with a dust-brush attachment or use a dry paintbrush. Clean with a mild soap solution. Scrub, and rinse. Avoid using too much water, which can weaken the fibers. Avoid sitting on the wicker when still damp, which can cause wicker to sag.

**Metal Furniture Care:** Because most metals, except aluminum, are subject to rust, metal furniture is usually finished with layers of clear varnish, paint, or a durable powder coating. Use a mild soap solution, and scrub, rinse, and dry. After cleaning, apply a coat of quality liquid or paste auto wax with a lint-free cloth if recommended by the furniture's manufacturer. Use a silicone spray to lubricate swivels and glides on chairs

**Butcher Block Care:** For best results, clean finished butcher block surfaces with soapy water or commonly available kitchen counter top cleaners. Do not use abrasives or powder cleansers. Do not allow moisture stand on the surface for prolonged periods of time. To sanitize, rinse the butcher block with white vinegar by using a vinegar-water solution in a spray bottle, spritz the butcher block all over. Let sit for a while. While that sits, make a lemon salt mixture by pouring about 1/4 cup salt into a bowl, and stir in enough lemon juice to make a paste, adjust the consistency as you go, to make a workable paste. The final step, using a scrub brush, thoroughly scrub your butcher block with the lemon-salt paste. If the paste gets too dry, sprinkle on a little more lemon juice. Rinse well, and squeegee off as much water as you can, and then let it dry overnight. Make sure to seal it before you get it dirty

again. Pour out a small amount of oil, and rub it into the wood using a cloth or paper towel. As the oil soaks in, add more and continue rubbing and polishing with the grain until the oil is absorbed. The first time you seal your butcher block, it may take several applications before it stops "drinking" oil, but in later cleanings you'll just need to refresh it. Keep adding oil until no more soaks in, remove any excess with a cloth.





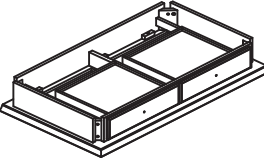
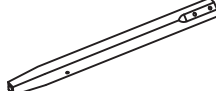
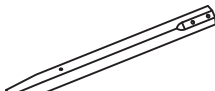
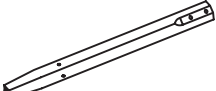
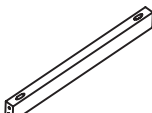
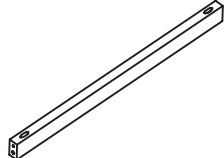

**Outdoor Cushion Care:** Please note our cushions are made from a polyester foam, and the covers are made from a moisture resistant polyester blend. This does not mean they are waterproof! Cushions should be stored and covered when not in use to protect them from rain, sunlight, and other staining agents. We do not recommend leaving cushions out in inclement weather, and if cushions become wet, please dry them immediately by removing the cushion from the cover so they can dry separately. Wring out any excess moisture before drying. Air dry only!

**Outdoor Furniture Storage:** We highly recommend storing any outdoor furniture during the winter and/or rainy seasons. Before storing your furniture, please ensure all moisture collected in the frame tubes has been drained out and dried. When outdoor furniture is not in use, we recommend covering all the furniture to protect it against the elements.

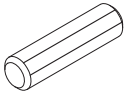
# PART LIST

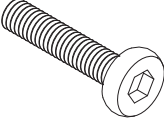
<b>A</b> 	<b>B</b> 	<b>C</b> 	<b>D</b> 	<b>E</b> 
<b>Top Panel</b> 1 PC	<b>Left Front Leg</b> 1 PC	<b>Right Front Leg</b> 1 PC	<b>Back Leg</b> 2 PCS	<b>Side Rail</b> 2 PCS
<b>F</b> 				
<b>Back Rail</b> 1 PC				

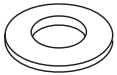
# HARDWARE LIST

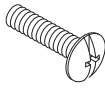
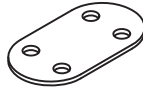
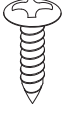
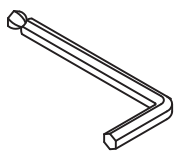
<p><b>#1</b></p> 	<p><b>#2</b></p>  <p>1-1/2"×Ø4×D8mm</p>	<p><b>#3</b></p>  <p>1-3/4"×Ø1/4"×D11mm</p>	<p><b>#4</b></p> 	<p><b>#5</b></p> 
<p>Wood Dowel 7 PCS(Extra 1)</p>	<p>Screw 7 PCS(Extra 1)</p>	<p>Hex Socket Head Bolt 9 PCS(Extra 1)</p>	<p>Spring washer 9 PCS(Extra 1)</p>	<p>Flat Washer 9 PCS(Extra 1)</p>
<p><b>#6</b></p> 	<p><b>#7</b></p>  <p>1-1/4"×Ø5/32"×D9mm</p>	<p><b>#8</b></p> 	<p><b>#9</b></p>  <p>14mm×Ø3×D6mm</p>	<p><b>#10</b></p> 
<p>Knob 2 PCS</p>	<p>Round Head Bolt 3 PCS(Extra 1)</p>	<p>Metal Plate (Only for use with Hutch) 2 PCS</p>	<p>Round Head Screw (Only for use with Hutch) 9 PCS(Extra 1)</p>	<p>Allen Wrench 1 PC</p>

## ADDITIONAL TOOLS (Not Provided)

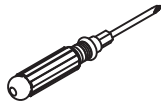

Note: It is not recommended to use power tools during assembly.



Phillips Head Screwdriver

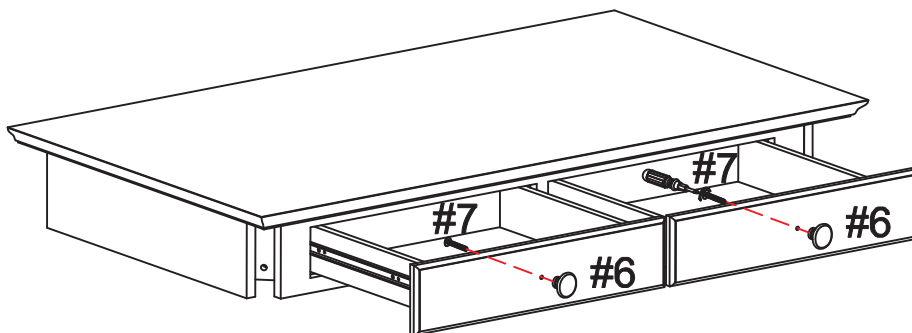

Step 1. Attach knobs (part #6) to the drawers using round head bolts (part #7) and Phillips head screwdriver.

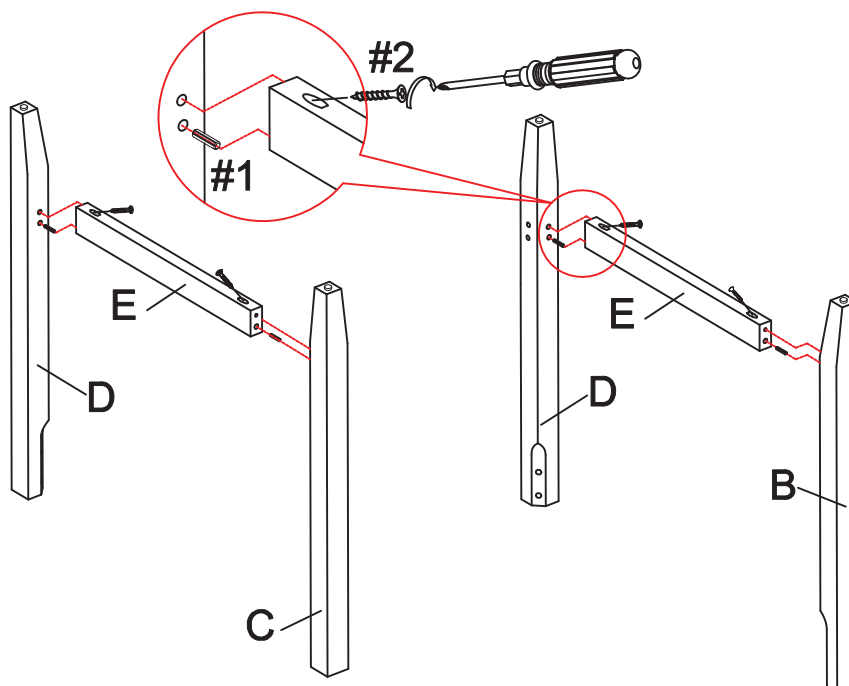

#6  x2  
#7  x2

Step 2. Attach side rail (part E) to right front leg (part C) and back leg (part D) using wood dowels (part #1), screws (part #2) and Phillips head screwdriver. Attach side rail (part E) to left front leg (part B) and back leg (part D) using wood dowels (part #1), screws (part #2) and Phillips head screwdriver.



#1  x4  
#2  x4

Step 3. Carefully lay top panel (part A) upside down on a soft surface as shown. Attach assembled legs (parts B & D) to top panel (part A) using flat washers (part #5), spring washers (part #4), hex socket head bolts (part #3), and allen wrench (part #10) as shown below.

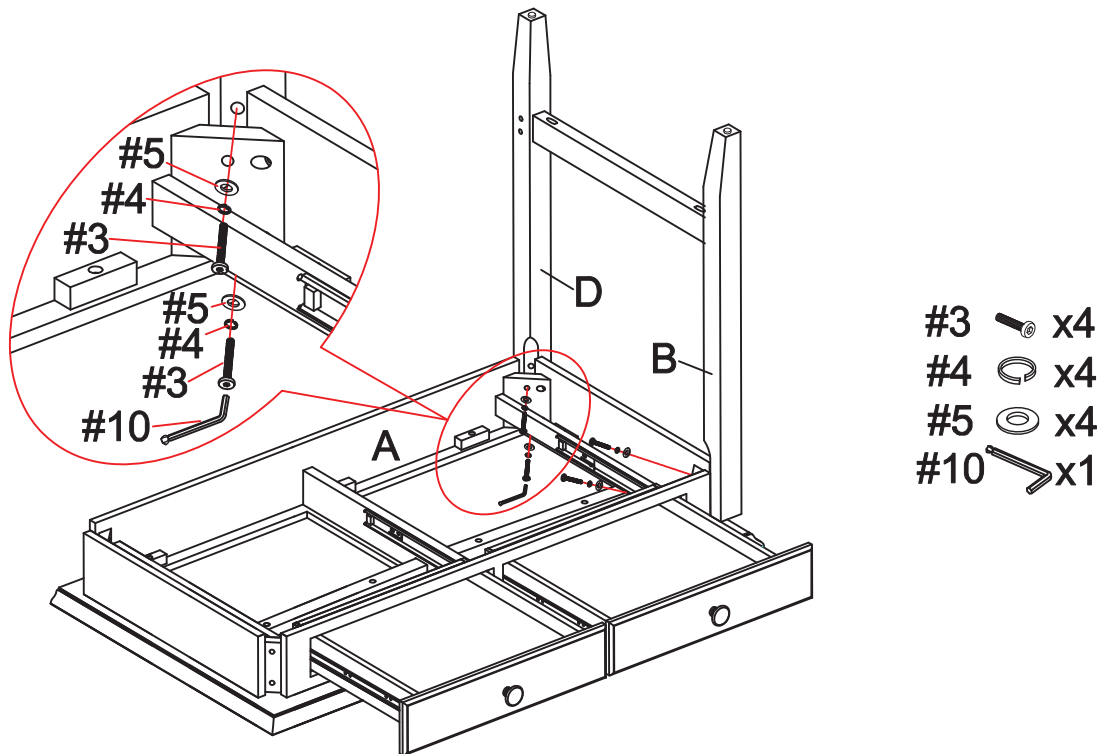

Step 4. Attach back rail (part F) to back legs (part D) using wood dowels (part #1), screws (part #2) and Phillips head screwdriver. Attach assembled legs (parts C & D) to top panel (part A) using flat washers (part #5), spring washers (part #4) hex socket head bolts (part #3), and allen wrench (part #10) as shown.

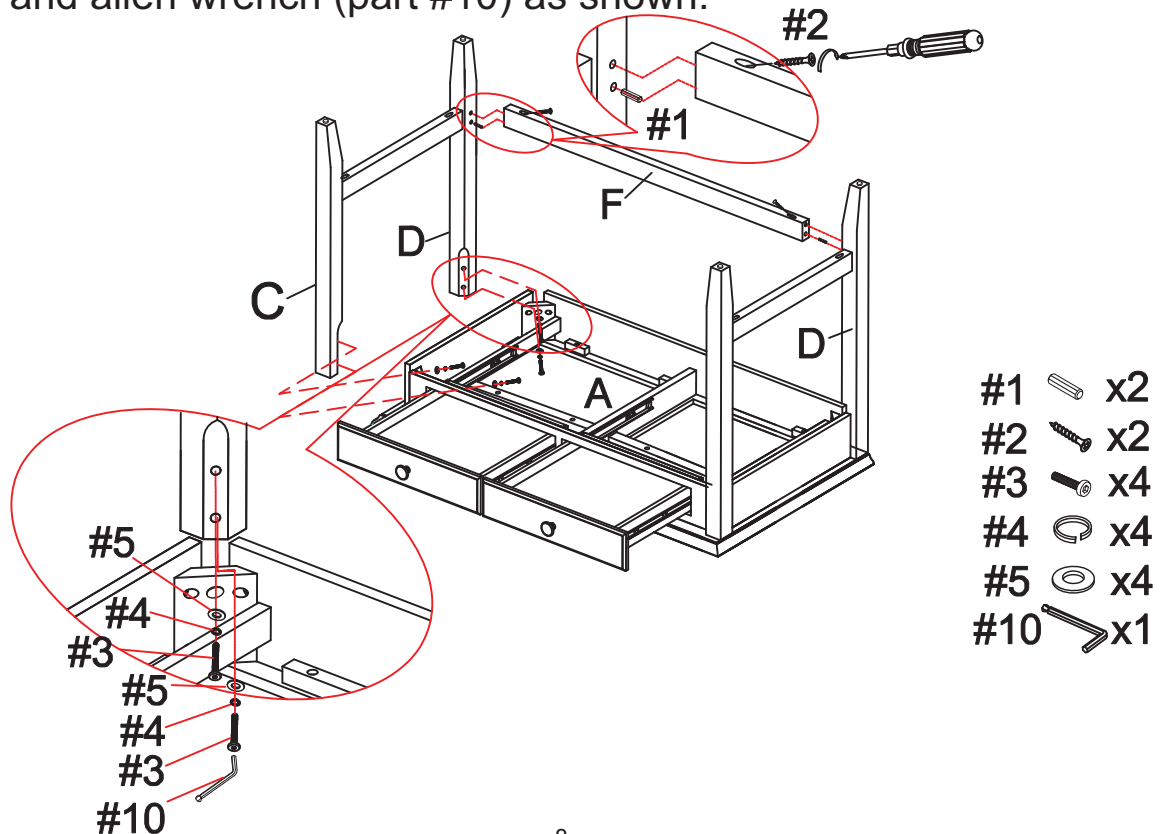

Step 5. Carefully flip desk upright.

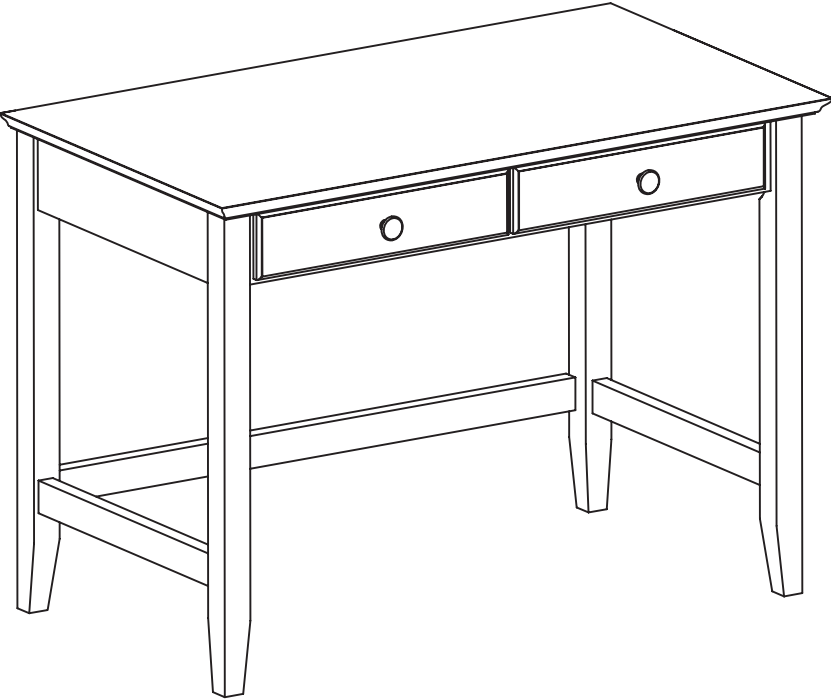

## Limited Manufacturers Warranty

Products are warranted against defects against material and workmanship for a period of 90 days beginning from the date of sale.

**Should you experience any damaged, defective, or missing parts, or need help with assembly, please call us directly before contacting the retailer.**

This warranty gives the purchaser specified legal rights in addition to any rights which may vary from state to state. In accordance with the "Moss-Magnuson Warranty Act" of July 10th, 1975, this is termed a "limited warranty" which in no way compromises our high standards of Quality and Workmanship.

## RETURNS POLICY

- Please note: This policy applies ONLY to products purchased directly through us. If purchased through a retailer please reference that retailer's return policy. Clearance items, used, demo, or products marked as 'Sold As Is' may not be returned or exchanged because all Clearance sales are final.
- Return Authorizations (RA) for all Furniture MUST be requested within 15 days of product delivery date.
- All returns must be authorized through the Consumer Service Team and must be for valid reasons associated with defects, damages, mislabeling or misrepresentation of the product. Requests for Return Authorizations (RA) resulting from 'Buyer's Remorse', partially assembled products, or products displaying damage from neglect or abuse on the part of the consumer will not be approved. Products returned without an RA will not be eligible for a refund.
- For any questions about or to be issued a Return Authorization (RA) number, please call the Consumer Services, or contact us via our website
- We recommend keeping the original box and packaging so that any returns can be repacked and shipped safely. If the original box and packaging has been discarded or recycled, or if the original packaging is not available, then the responsibility of securely repacking the product is the responsibility of the consumer. Authorized returns must meet the following conditions for a refund to be processed:
  1. The Product must be in new/unused condition
  2. The Product must be returned with all accessories and parts securely packed in the original box and packaging, or packaging provided by the consumer that prevents damage during return shipping.
- Shipping charges back to us will be deducted from the refund amount, and will be equal to the shipping charges on the original sales order.
- Furniture returns are subject to a 15% restocking fee for all authorized returns. This restocking fee covers the costs associated with inspecting and returning the product to stock, and will be deducted from the refund amount.
- We will waive the restocking fee if the product is exchanged for another product of equal or greater value. Any price differences will be charged accordingly, and fees associated with shipping will still be applicable.
- Authorized returns are inspected immediately upon receipt. Any approved exchanges, credits and refunds will be issued for the purchase price of the item(s) at that time less any applicable fees; taxes are refunded in accordance with state law.
- Refunds and credits are issued based on the payment method used at the time of purchase. Please allow up to 21 days following receipt of the authorized return (not including weekends and holidays) for any credit or refund to show up on a credit card statement. A copy of the refund transaction can be requested from a Consumer Services Team member.

## CANCELLATION POLICY

Our products usually ship within two business days. If you change your mind about a purchase, please contact Consumer Services as soon as possible. If we are able to stop the order before it has been released for shipment, we will cancel the order without penalty. If the item has already shipped, please see our Returns Policy above for more information.

## FREIGHT DAMAGE OR DEFECTS

On occasion, freight damage and factory defects may occur, and we will do our best to promptly replace any parts that are covered by our limited warranty included for all furniture products. Please note that parts replaced under warranty will be shipped via Ground Shipping only. Replacement parts will not be expedited unless the consumer is willing to pay for the extra charges. (See Warranty Policy Page). Please take pictures or note any damage upon delivery and provide this information to a Consumer Services Team member when you contact us. With this feedback, we will continue to improve our products, packaging and shipping methods, and when necessary, we will file claims with the shipping company.