



# ASSEMBLY INSTRUCTIONS & PARTS IDENTIFICATION STORAGE BENCH

Thank you for purchasing this quality product. Be sure to check all packing material carefully for small parts that may have come loose inside the carton during shipment.

| Key Parts |       |        |                                 |
|-----------|-------|--------|---------------------------------|
| No        | Code  | Q'ty   | Description                     |
| 1         | BBC   | 1 pc.  | Bench Back Complete             |
| 2         | WST   | 1 pc.  | Wood Seat Top                   |
| 3         | SSB   | 1 pc.  | Seat Storage Box                |
| 4         | RFLA  | 1 pc.  | Right Facing Leg Assembly       |
| 5         | LFLA  | 1 pc.  | Left Facing Leg Assembly        |
| 6         | LG    | 4 pcs. | Floor glide                     |
| 7         | H     | 3 pcs. | Hinge                           |
| 8         | LSFSH | 1 pc.  | Left Side Facing Support Hinge  |
| 9         | RSFSH | 1 pc.  | Right Side Facing Support Hinge |

| Hardware kit |      |  |        |
|--------------|------|--|--------|
| No           | Code | Description  | Q'ty   |
| A            | BLT  |  Bolt Ø6 x 60mm | 8 pcs. |
| B            | SCRW |  Screw Cap      | 8 pcs. |
| C            | ALK  |  Allen Key      | 1 pc.  |

## STEP 1

- Carefully lay Right or Left Facing Leg Assembly on a smooth flat surface to prevent scratches.
- Affix Back Complete and Seat Storage box to Leg Assembly by inserting a Bolt (B) into each of the hole on the Leg Assembly. (See Detail A).
- Tighten bolts with provided Allen Key (C) by turning clockwise until secure.

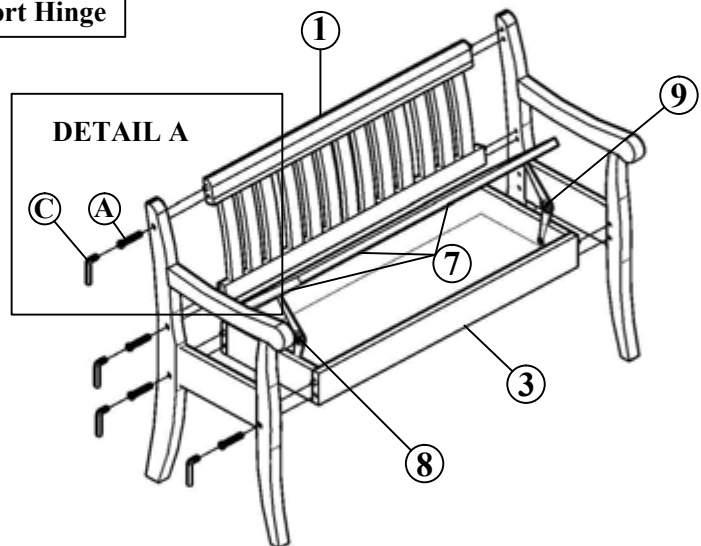

## DETAIL B

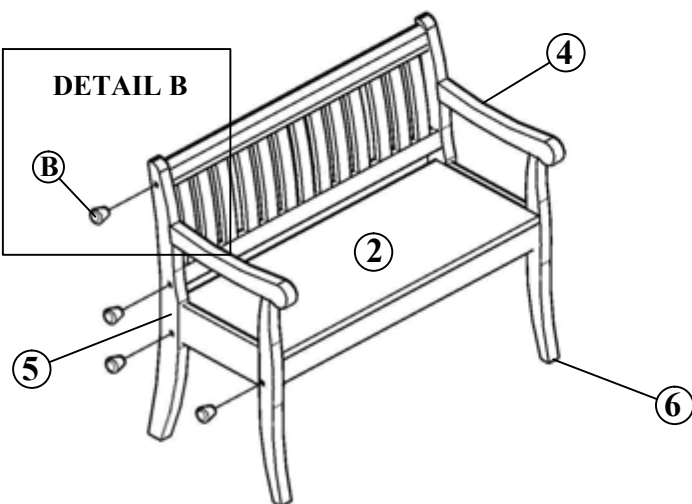

## STEP 2

- Be sure to level the Bench prior to tightening all the bolts.
- Insert the Screw Cap into all holes side Bench. (See Detail B).