







# ASSEMBLY INSTRUCTION

Description : Arrowback Chair

No	Part List	Qty
A	Chair Back	1
B	Legs Frame	2
C	Stretchers ( Short)	1
D	Stretchers ( Long)	1

No	Hardware List	Qty
E	JCBC Bolt M6 x 50 mm 	2
F	Barrel Nut 	2
G	JCBC Screw M7 x 35mm 	6
H	Allen Key 	1
I	Wood Button 	2

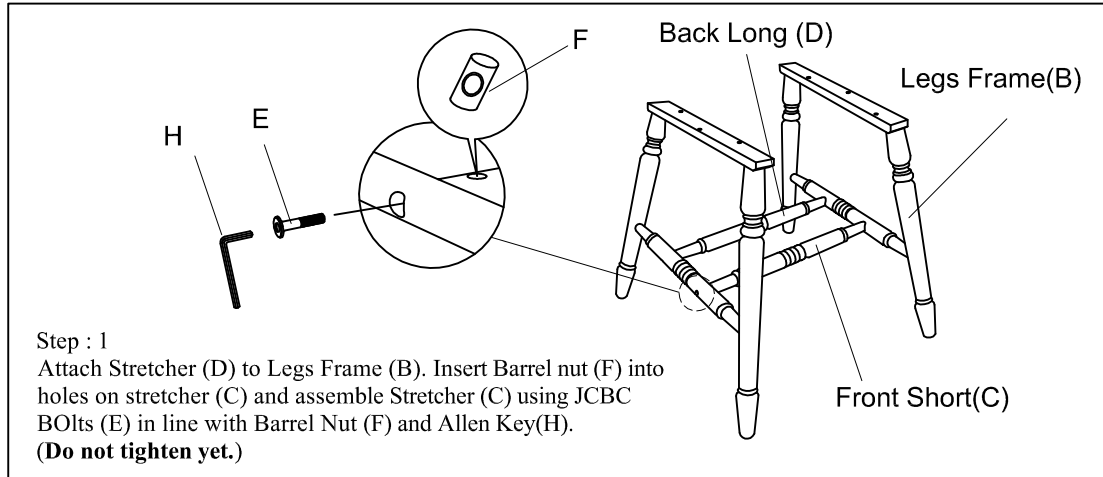

**Step : 1**  
Attach Stretcher (D) to Legs Frame (B). Insert Barrel nut (F) into holes on stretcher (C) and assemble Stretcher (C) using JCBC BOLts (E) in line with Barrel Nut (F) and Allen Key(H).  
**(Do not tighten yet.)**

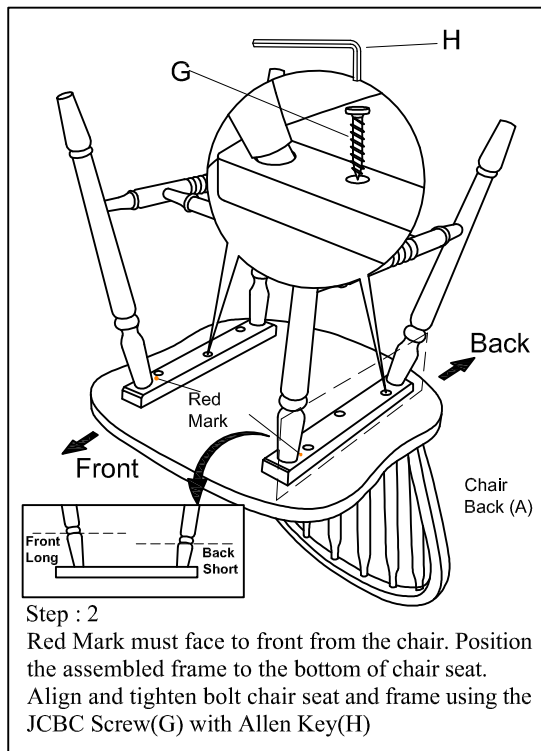

**Step : 2**  
Red Mark must face to front from the chair. Position the assembled frame to the bottom of chair seat. Align and tighten bolt chair seat and frame using the JCBC Screw(G) with Allen Key(H)

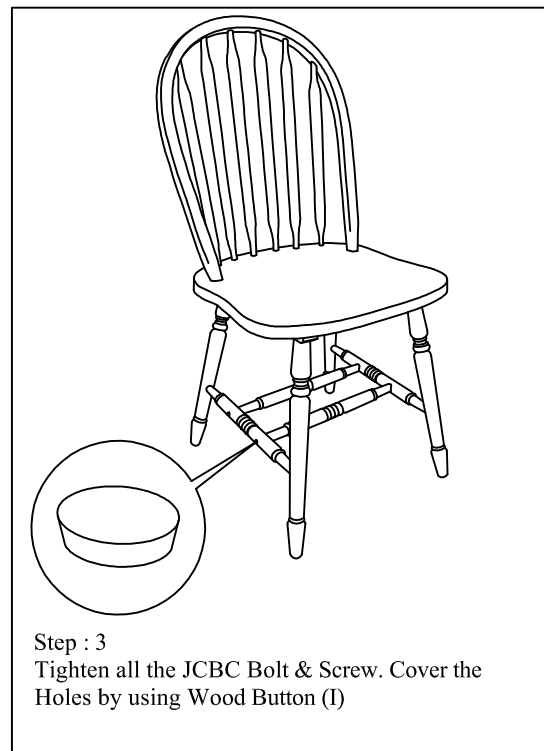

**Step : 3**  
Tighten all the JCBC Bolt & Screw. Cover the Holes by using Wood Button (I)

**Thank you for purchasing our product!**

Please assemble the products with the guidance of this manual instruction. Contact our friendly customer service department with any comments or in case there is any missing or damaged parts or hardware.

We appreciate your business!



**- After a few days of initial assembly and chairs have acclimated to new environment retighten all hardware.**

**Important Notes**