

# ASSEMBLY INSTRUCTIONS

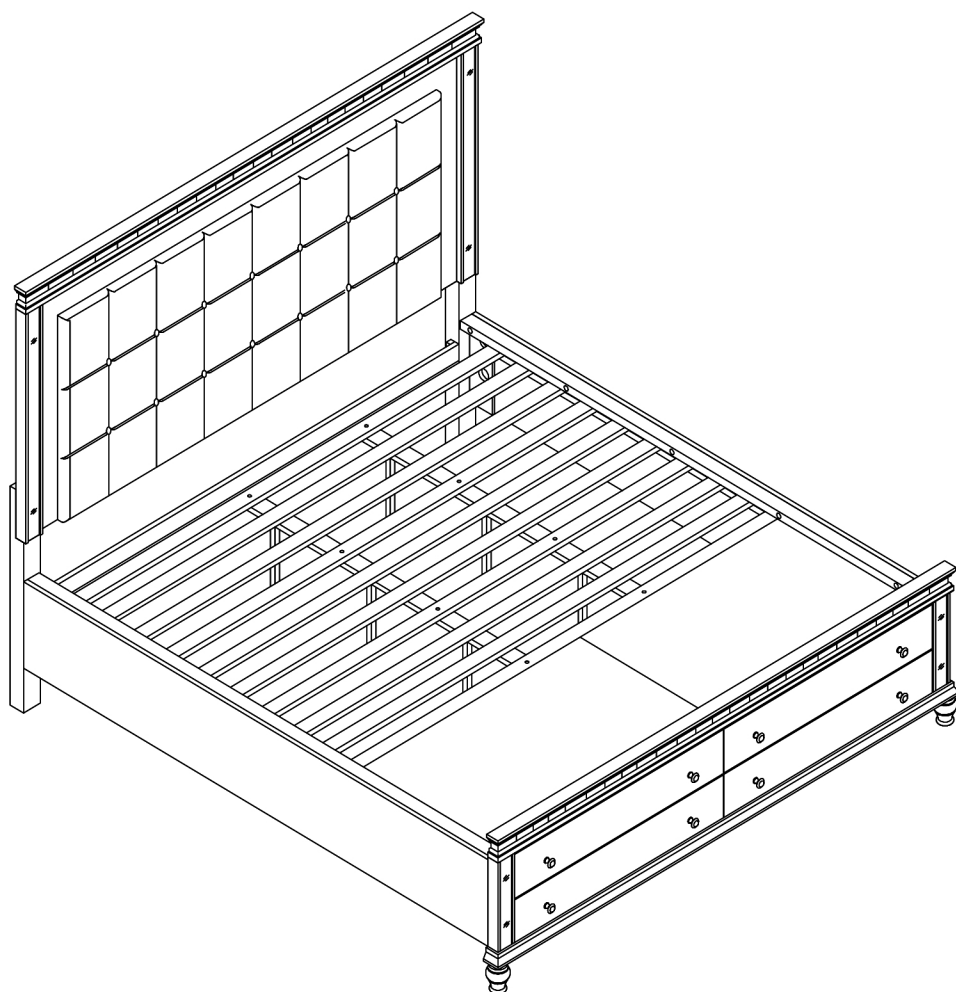

## TOOLS REQUIRED

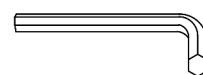

Allen Wrench  
(Included)



Phillips Screwdriver  
(Not Included)

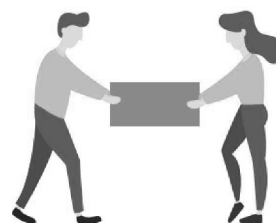

3 - People  
Recommended

## ASSEMBLY RATING



EASY —————> DIFFICULT

The Assembly Rating is a 5-point system showing the level of effort needed to assemble a specific product.



## **CHECK BEFORE STARTING**

### **Are you missing anything?**

Double-check all parts, hardware and accessories listed are all accounted for.

### **Check out our Quick Tips!**

We recommend reviewing the pre-assembly handouts. Even experts need a refresher now and then!

### **Should we send any replacements?**

Are there any irregularities or flaws in the parts? We can send replacements!

### **Prep Time!**

Please review the assembly instructions and all diagrams prior to assembling.

# PRE ASSEMBLY INTRODUCTION

We understand building ready-to-assemble furniture can be a challenging experience for some. To help avoid confusion, we have provided some helpful tips that may speed up the process.

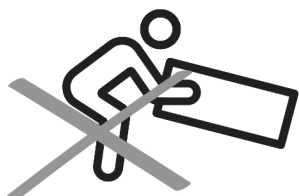

## Teamwork

ALWAYS have at least two people to help with transporting and assembling the product to avoid potential injury and/or damage.

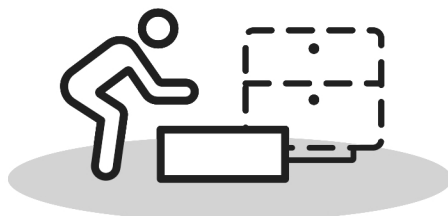
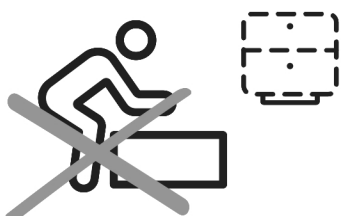

## Suitable Location

Assembling near the area of the intended location is highly recommended.



## Sufficient Space

Make sure you have enough space to move around during the assembly.

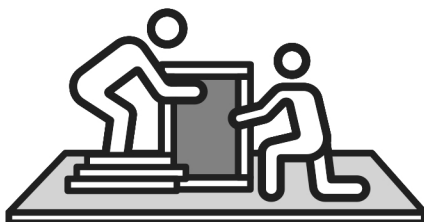

## Avoid Scratches

Use cardboard, blankets or a carpeted area while assembling furniture to prevent to prevent scratches and damages.

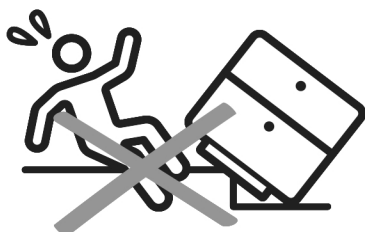

## Flat Surface

Make sure the furniture rests on a flat and level surface with each leg evenly touching the floor.

# ASSEMBLY AND CARE ADVICE



**FAILURE TO FOLLOW THE GUIDELINES BELOW MAY RESULT IN INJURY AND/OR PROPERTY DAMAGE.**



Position each part correctly and insert screws or bolts into their respective holes.

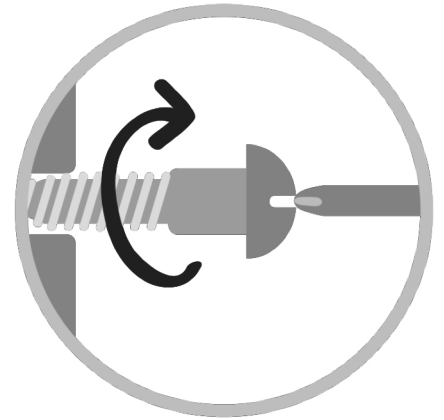

Turn clockwise to tighten and only tighten when step is completed or when instructed to do so.



Use the appropriate hand tools or power tools for assembly. Select steps, such as tightening screws and/or bolts, may require hand tools to avoid causing damage during assembly.



Save the instructions and store any supplied tools for later maintenance.



After two weeks, check and tighten any loose hardware and repeat again every six months thereafter.

**IT IS THE USER'S RESPONSIBILITY TO MAINTAIN THE FURNITURE. THE HARDWARE MAY LOOSEN OVER TIME AND MAY CAUSE THE FURNITURE TO BE WOBBLY AND UNABLE TO SUPPORT ITS INTENDED WEIGHT CAPACITY. THIS MAY LEAD TO COLLAPSE AND MAY CAUSE SERIOUS INJURY.**

# BED



- Please keep instructions for future reference.
- Check the quantity and irregularity of parts and hardware before you start.

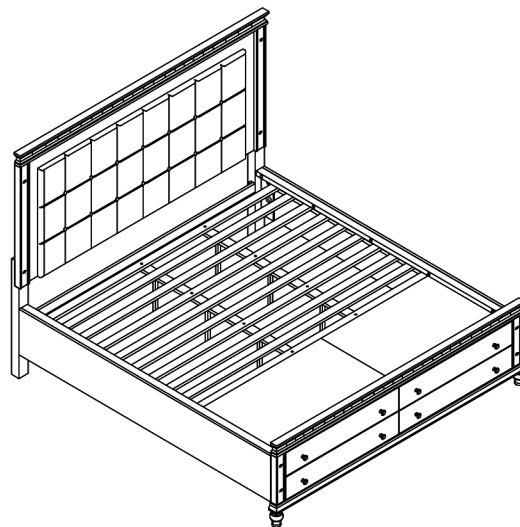

## PARTS

#1 1pc

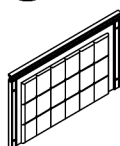

Headboard Panel

#2 2pcs

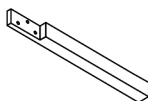

HB Leg (L&R)

#3 1pc

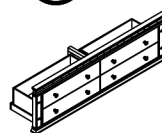

Footboard

#4 2pcs

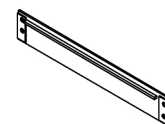

Side Rail

#5 1pc

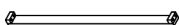

HB Support

#6 1set

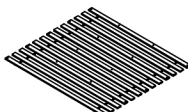

Bed Slats (13pcs)

#7 8pcs

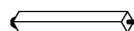

Support Leg

#8 2pcs



FB Leg

#9 2pcs

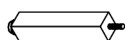

FB Support Leg

#10 2pcs

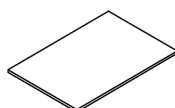

Conceal Panel

#11 2pcs

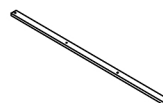

Slat Center Support

#12 2pcs



Top Bed Rail Support

## HARDWARE

#A 10pcs



Bolt  
Ø5/16" x 2"

#B 10pcs



Lock Washer  
Ø5/16"

#C 10pcs



Flat Washer  
Ø5/16"

#D 1pc



Allen Wrench  
4mm

#E 18pcs



Screw  
#4 x 1-3/16"

#F 8pcs



Threaded Pins  
Ø5/16" x 3-1/2"

#G 8pcs



Half Moon Washer  
Ø5/16"

#H 8pcs



Hex Nut  
Ø5/16"

#I 1pc

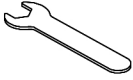

Wrench  
12mm

#J 8pcs



Screw  
#4 x 5/8"

#K 10pcs



Bolt  
Ø1/4" x 2"

#L 10pcs



Lock Washer  
Ø1/4"

#M 10pcs



Flat Washer  
Ø1/4"

#N 1pc







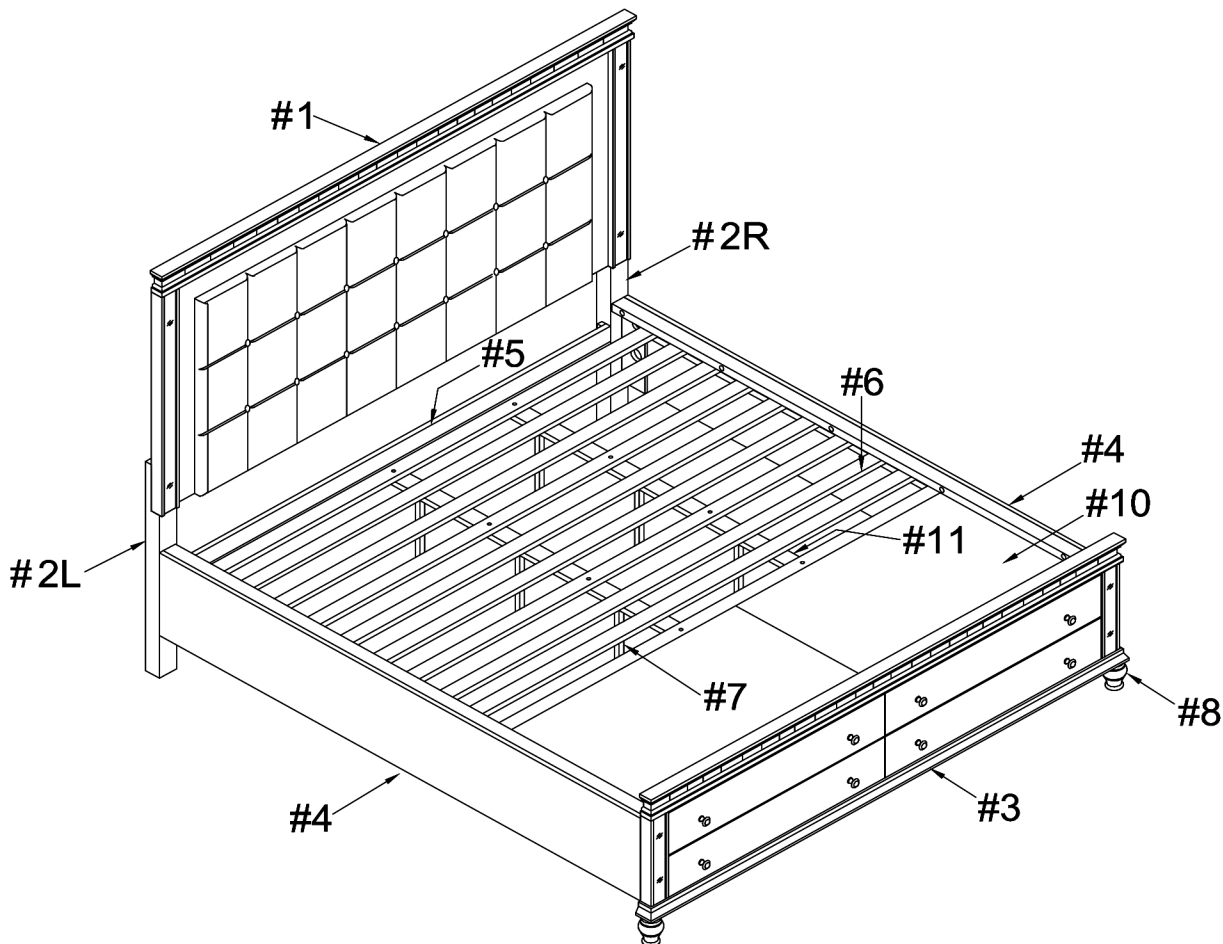



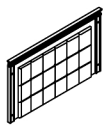

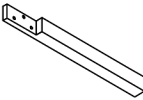



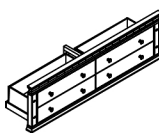

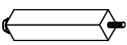
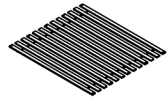
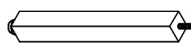
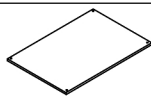

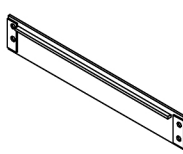
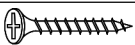

Allen Wrench  
4mm

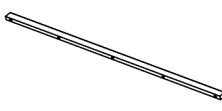
# Exploded View



# packing in 3 cases

Carton	Designation	Part	Hardware
	Headboard Panel	#1 	 #A 10pcs
	HB Leg (L/R) (2pcs)	#2 	 #B 10pcs
	HB Support	#5 	 #C 10pcs  #D 1pc
	Footboard	#3 	
	FB Leg (2pcs)	#8 	
	FB Support Leg (2pcs)	#9 	
	Bed Slats	#6 	
	Support Leg (8pcs)	#7 	
	Conceal Panel (2pcs)	#10 	
	Slat Center Support (2pcs)	#11 	
	Side Rail (2pcs)	#4 	 #E 18pcs  #F 8pcs  #G 8pcs  #H 8pcs  #I 1pc
	Top Bed Rail (2pcs)	#12 	 #J 8pcs  #K 10pcs  #L 10pcs  #M 10pcs  #N 1pc

# ASSEMBLY INSTRUCTIONS

## 1

- Part #1 x1pc
- Part #2 x2pcs
- Part #5 x1pc
- Hardware #A x10pcs
- Hardware #B x10pcs
- Hardware #C x10pcs

Align and attach HB Leg (#2), HB Support (#5), and Headboard Panel (#1) using Bolt (#A) with Washers (#B, C)

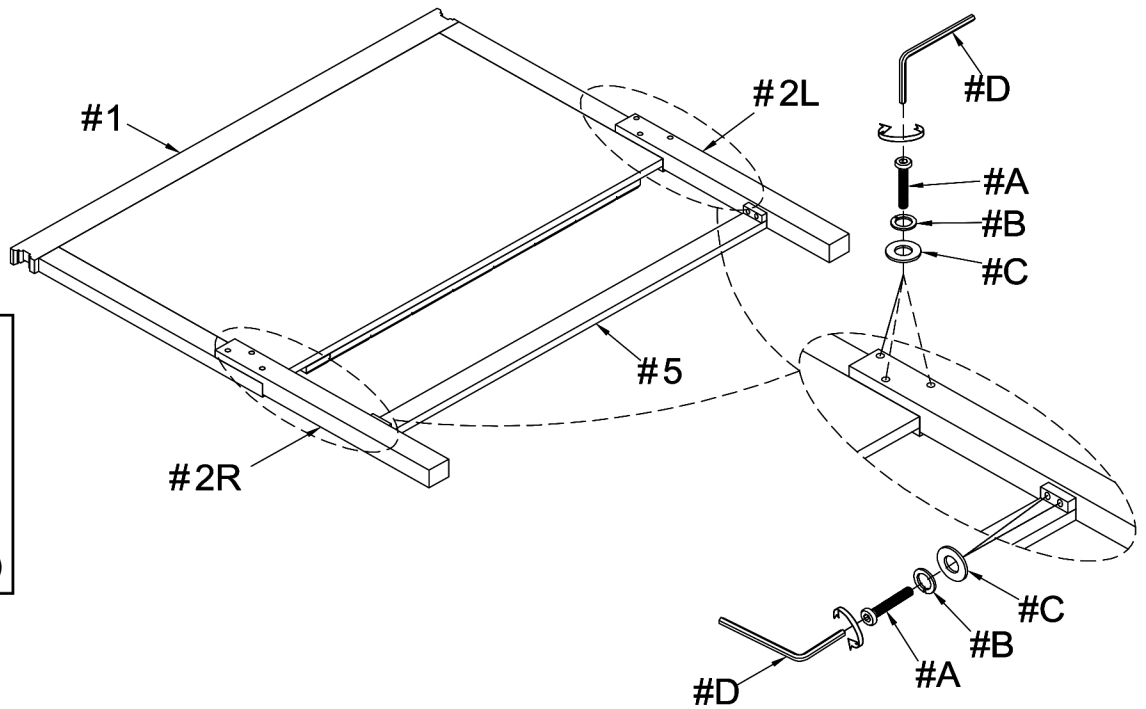

## 2

- Part #3 x1pc
- Part #8 x2pcs
- Part #9 x2pcs

Screw FB Leg (#8) and FB Support Leg (#9) to Footboard (#3)

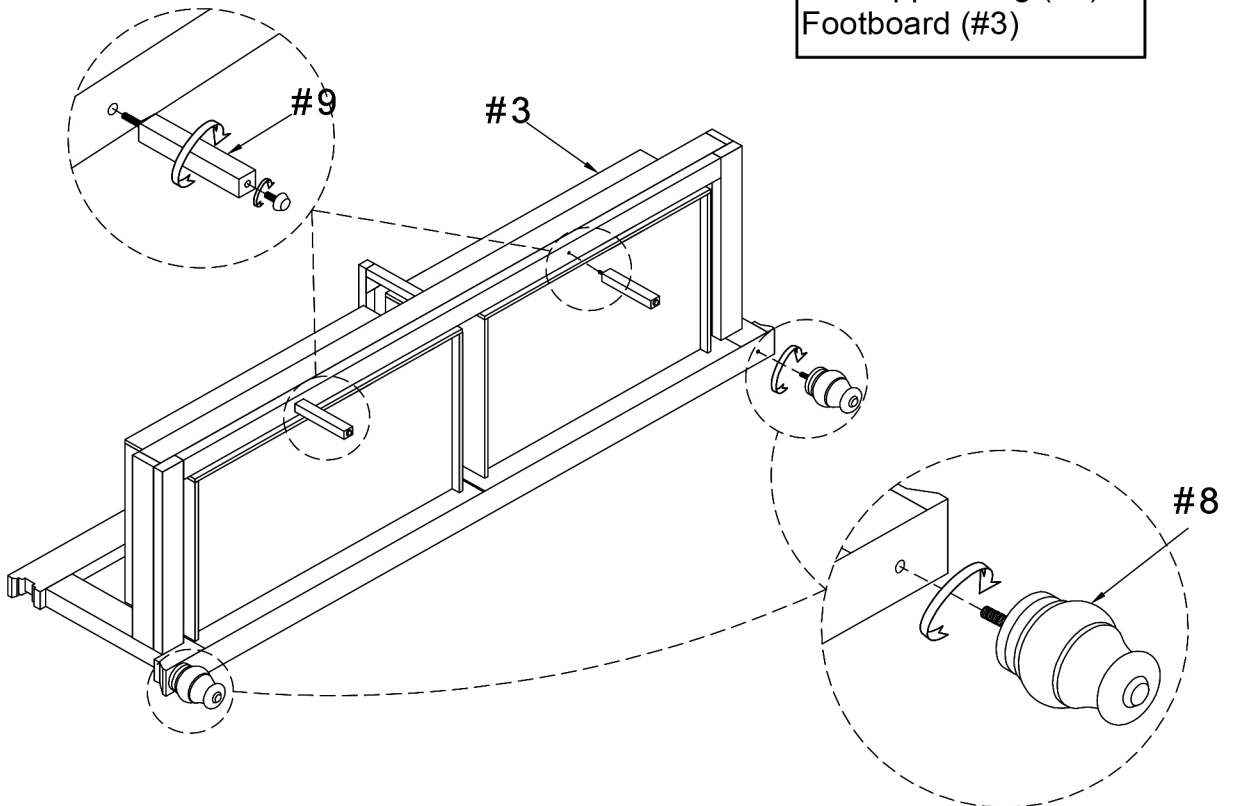

# ASSEMBLY INSTRUCTIONS

## 3

Part (#4) x2pcs

Hardware (#F) x8pcs

Hardware (#G) x8pcs

Hardware (#H) x8pcs

Hardware (#I) x1pc

Align and attach Side Rail (#4) to HB Leg (#2) and Footboard (#3) using Threaded Pins (#F) with Washers (#G, H)

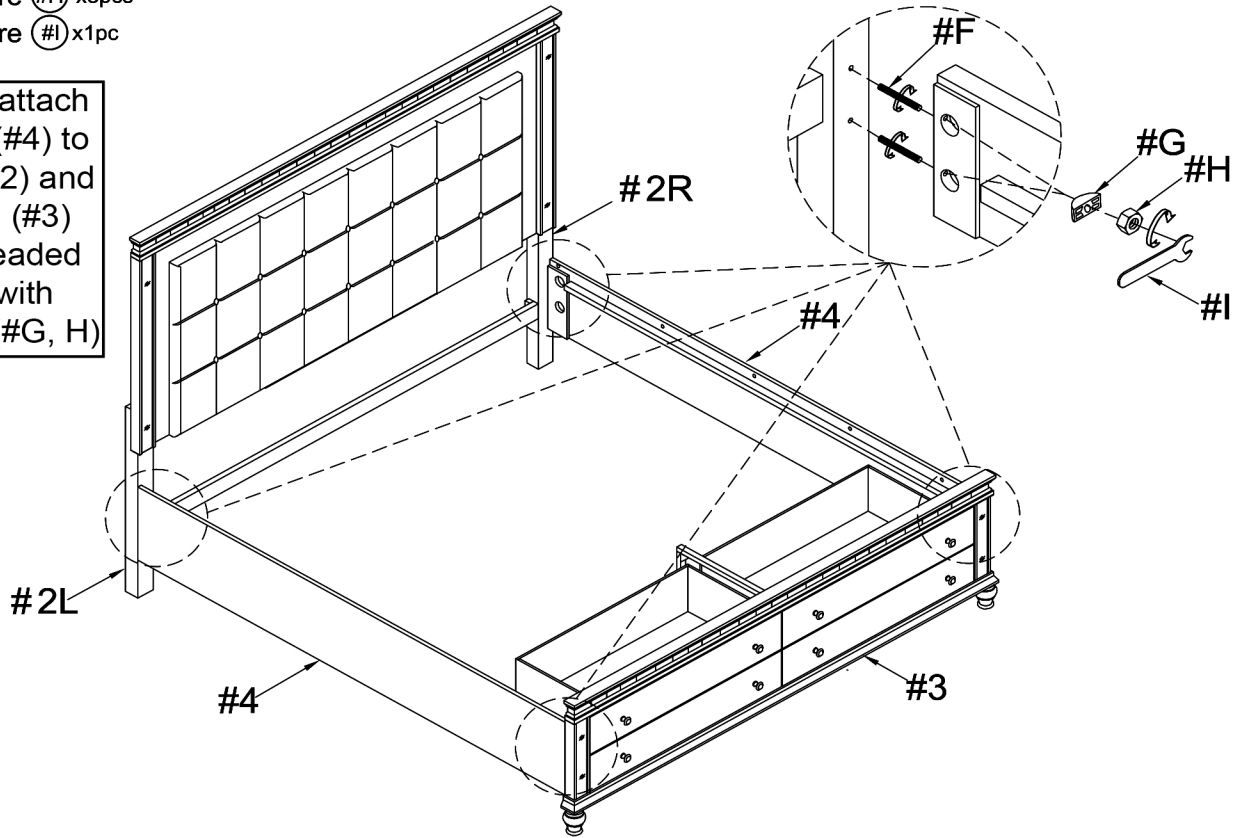

## 4

Part (#7) x4pcs

Part (#11) x1pc

Screw Support Leg (#7) to Slat Center Support (#11)

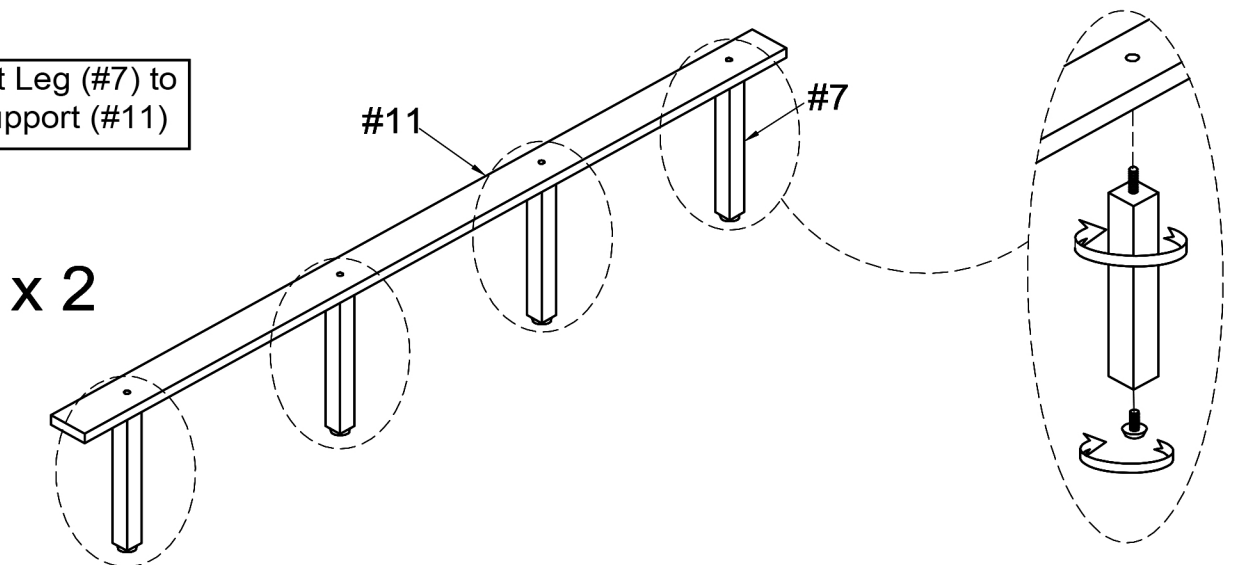

# ASSEMBLY INSTRUCTIONS

## 5

Part #6 x1set

Hardware #E x18pcs

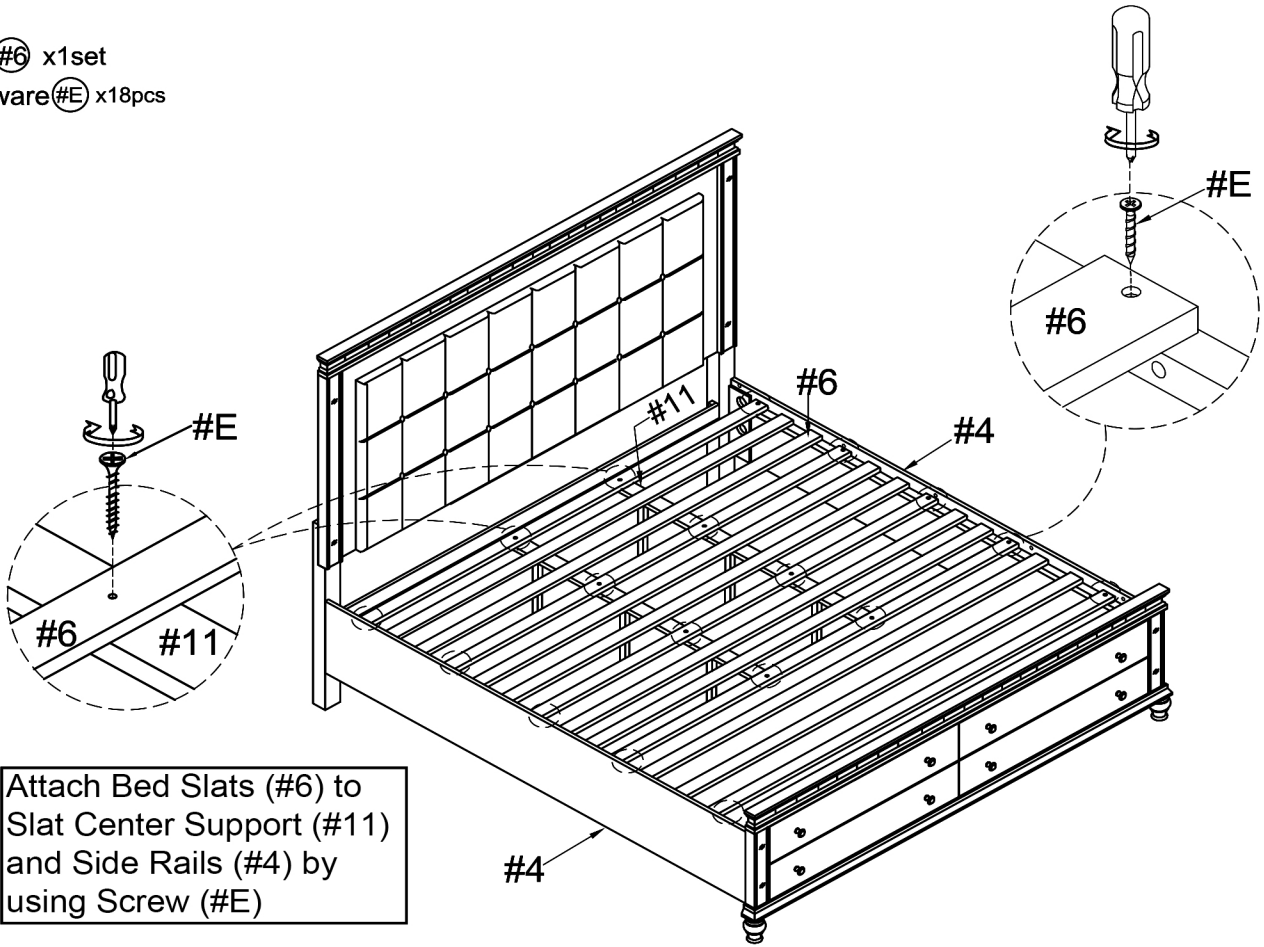

Attach Bed Slats (#6) to Slat Center Support (#11) and Side Rails (#4) by using Screw (#E)

## 6

Part #10 x2pcs

Place Conceal Panel (#10) unto Bed Slats (#6)

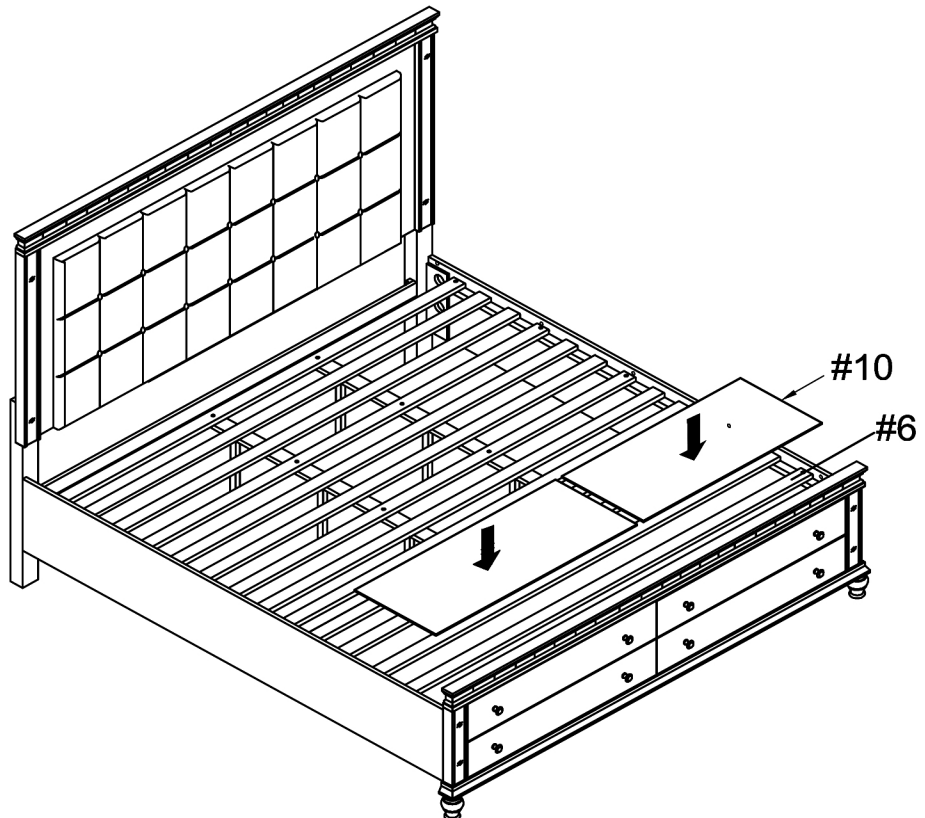

# ASSEMBLY INSTRUCTIONS

## 7

Hardware **#J** x8pcs

Screw Conceal Panel (#10) using Screw (#J)

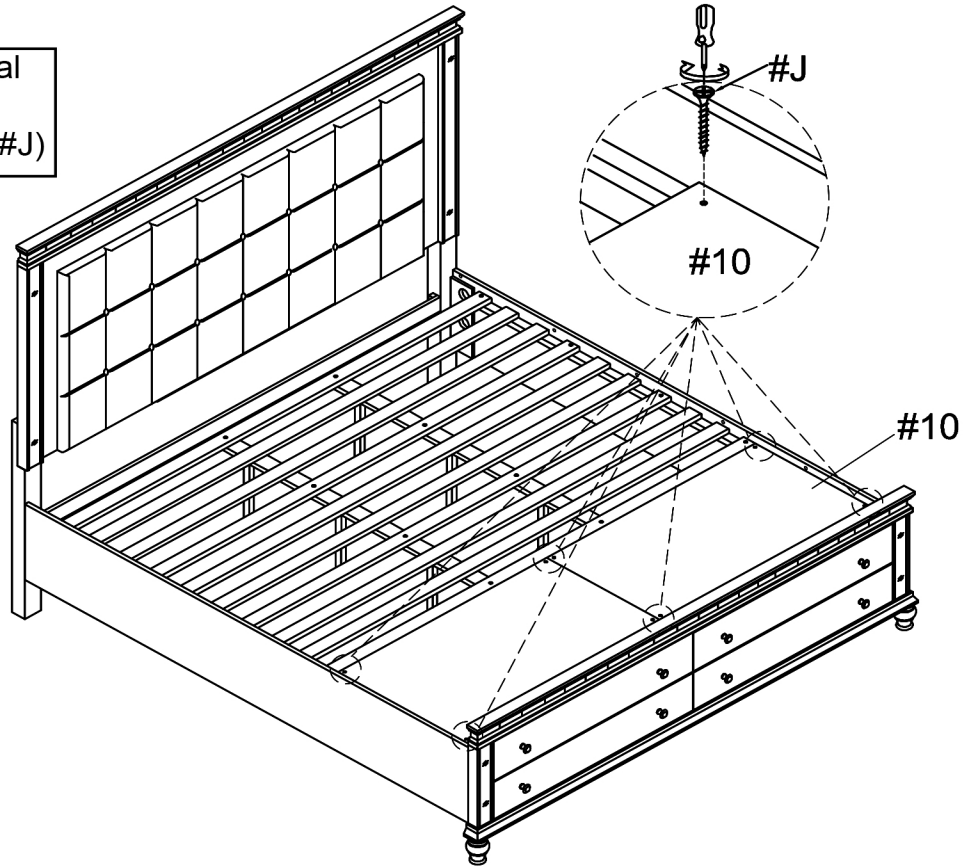

## 8

Part **#12** x2pcs

Hardware **#K** x10pcs

Hardware **#L** x10pcs

Hardware **#M** x10pcs

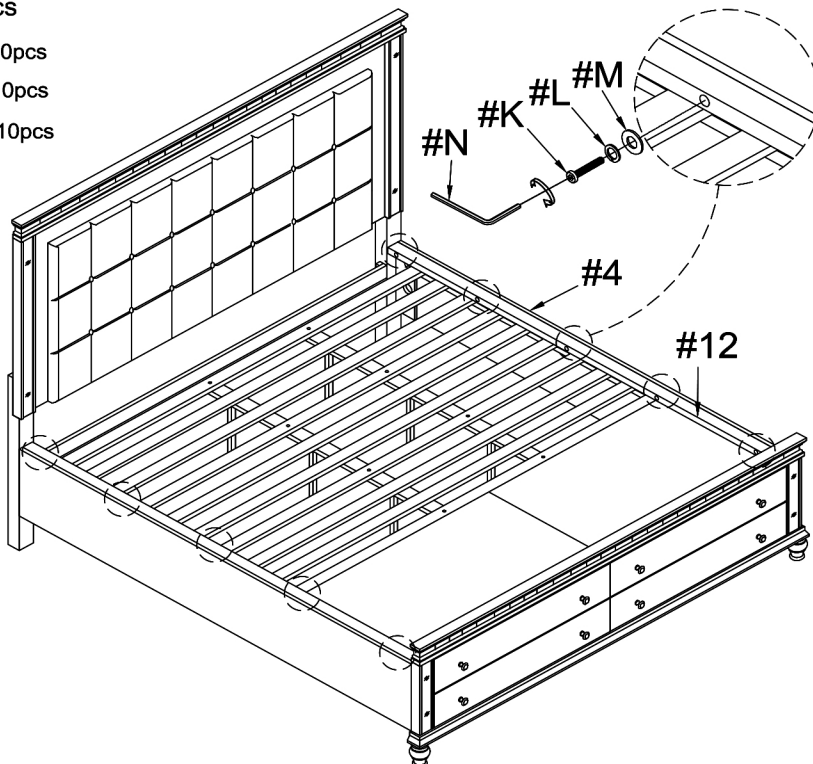

Align and attach Top Bed Rail (#12) using Bolt (#K) with Washers (L, M)

### ASSEMBLY COMPLETED



Please ensure the furniture rests on an even and flat surface. If the product wobbles or feels loose, double-check all bolts and/or screws are properly tightened and secured.



#### Keep this handy!

Please retain this instruction manual and any order-related information for future reference.



#### Lift, don't drag!

To avoid damage to product please always LIFT the product when transporting or adjusting the placement.

# ASSEMBLY INSTRUCTIONS

---

## TOOLS REQUIRED



Phillips  
Screwdriver

(Not Included)

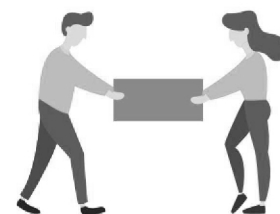

2 - People  
Recommended

## ASSEMBLY RATING



EASY —————> DIFFICULT

The Assembly Rating is a 5-point system showing the level of effort needed to assemble a specific product.

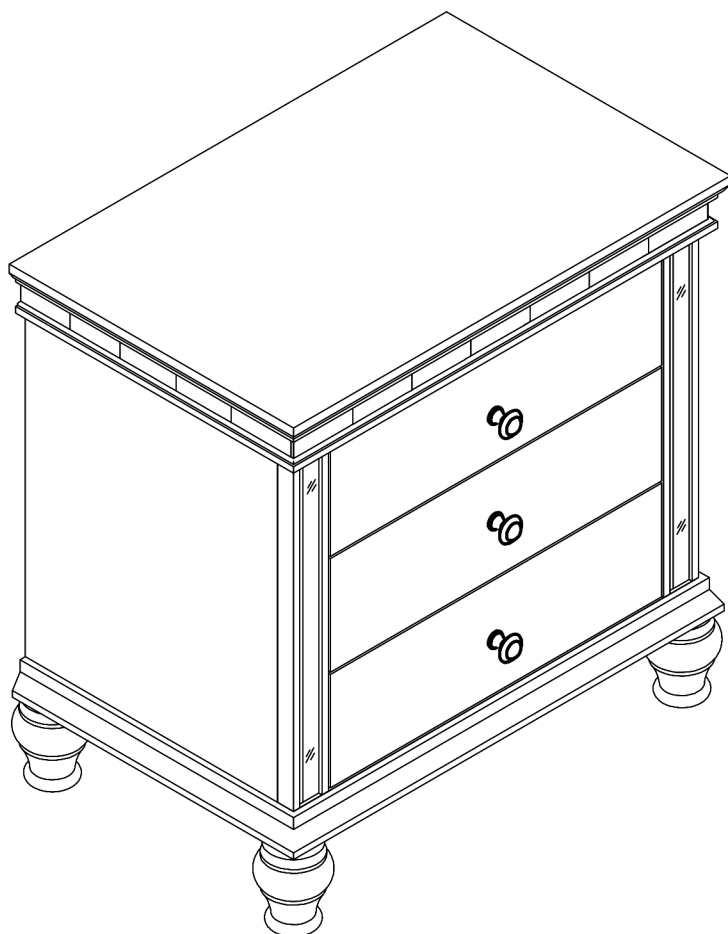



## **CHECK BEFORE STARTING**

### **Are you missing anything?**

Double-check all parts, hardware and accessories listed are all accounted for.

### **Check out our Quick Tips!**

We recommend reviewing the pre-assembly handouts. Even experts need a refresher now and then!

### **Should we send any replacements?**

Are there any irregularities or flaws in the parts? We can send replacements!

### **Prep Time!**

Please review the assembly instructions and all diagrams prior to assembling.

# PRE ASSEMBLY INTRODUCTION

We understand building ready-to-assemble furniture can be a challenging experience for some. To help avoid confusion, we have provided some helpful tips that may speed up the process.

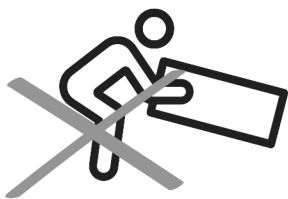

## Teamwork

ALWAYS have at least two people to help with transporting and assembling the product to avoid potential injury and/or damage.

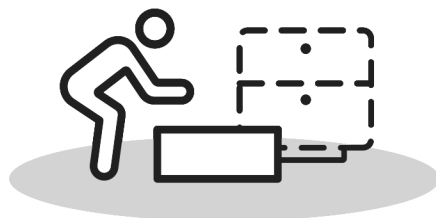

## Suitable Location

Assembling near the area of the intended location is highly recommended.

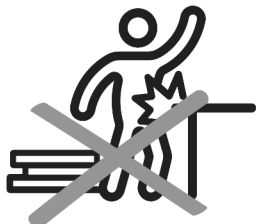

## Sufficient Space

Make sure you have enough space to move around during the assembly.

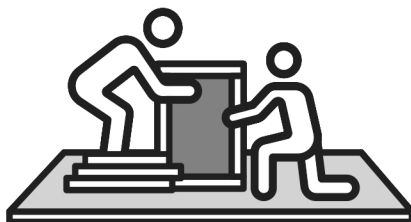

## Avoid Scratches

Use cardboard, blankets or a carpeted area while assembling furniture to prevent to prevent scratches and damages.

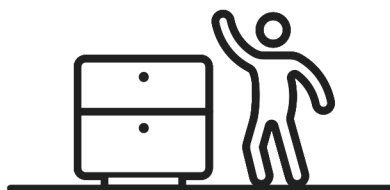
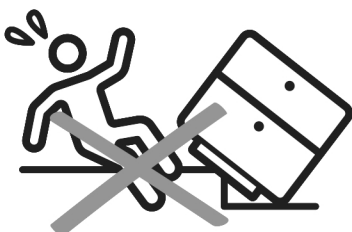

## Flat Surface

Make sure the furniture rests on a flat and level surface with each leg evenly touching the floor.

# ASSEMBLY AND CARE ADVICE



**FAILURE TO FOLLOW THE GUIDELINES BELOW MAY RESULT IN INJURY AND/OR PROPERTY DAMAGE.**



Position each part correctly and insert screws or bolts into their respective holes.

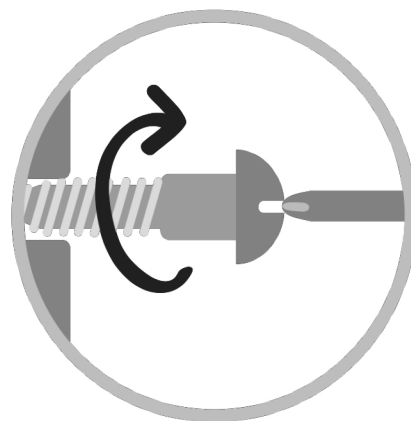

Turn clockwise to tighten and only tighten when step is completed or when instructed to do so.



Use the appropriate hand tools or power tools for assembly. Select steps, such as tightening screws and/or bolts, may require hand tools to avoid causing damage during assembly.



Save the instructions and store any supplied tools for later maintenance.

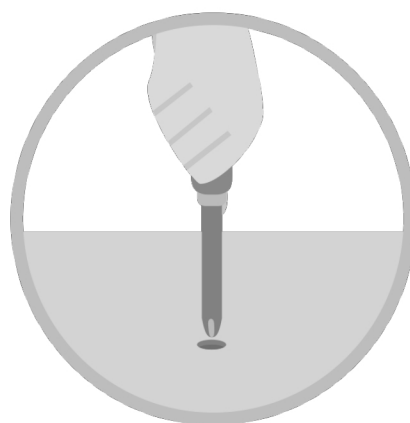

After two weeks, check and tighten any loose hardware and repeat again every six months thereafter.

**IT IS THE USER'S RESPONSIBILITY TO MAINTAIN THE FURNITURE. THE HARDWARE MAY LOOSEN OVER TIME AND MAY CAUSE THE FURNITURE TO BE WOBBLY AND UNABLE TO SUPPORT ITS INTENDED WEIGHT CAPACITY. THIS MAY LEAD TO COLLAPSE AND MAY CAUSE SERIOUS INJURY.**

# NIGHTSTAND

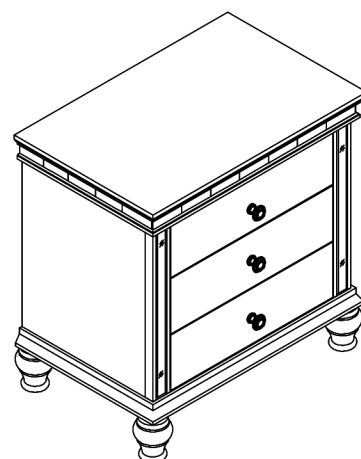
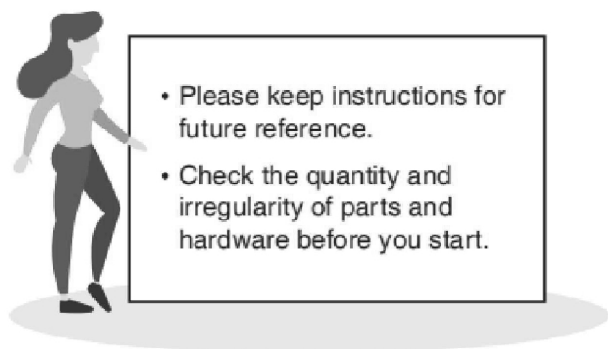

## PARTS

#1 1pc

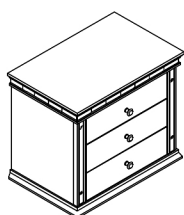

Nightstand

#2 4pcs



Leg

## HARDWARE

#A 1Set



Anti Tip Kit

# ASSEMBLY INSTRUCTIONS

# 1

Part #1 x1pc

Part #2 x4pcs

Screw Leg (#2) unto Nightstand (#1)

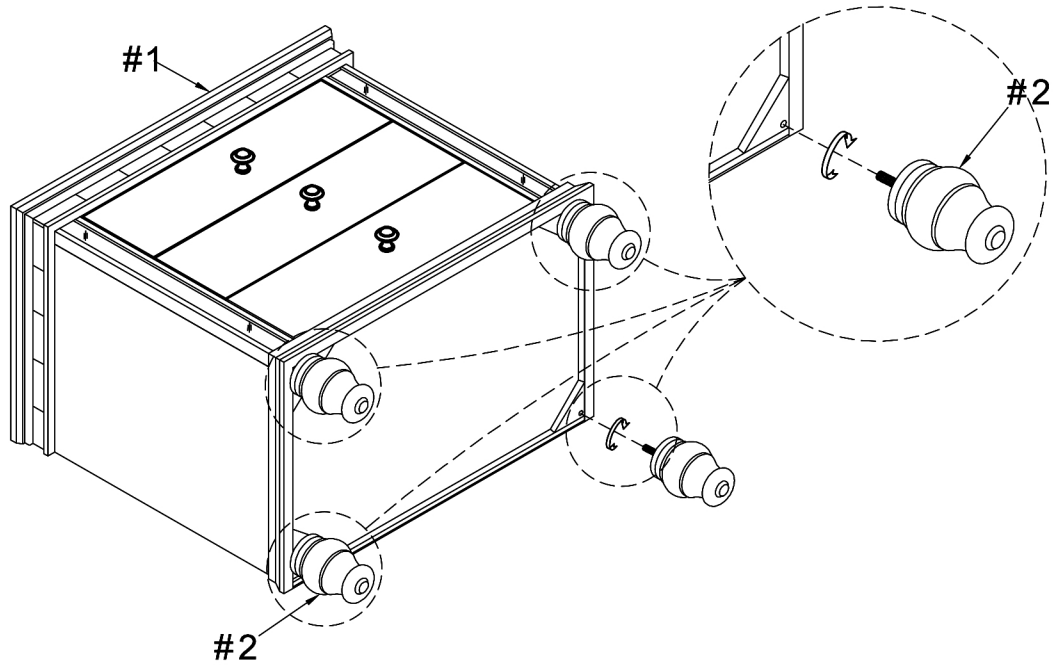

# 2

Hardware #A x 1Set

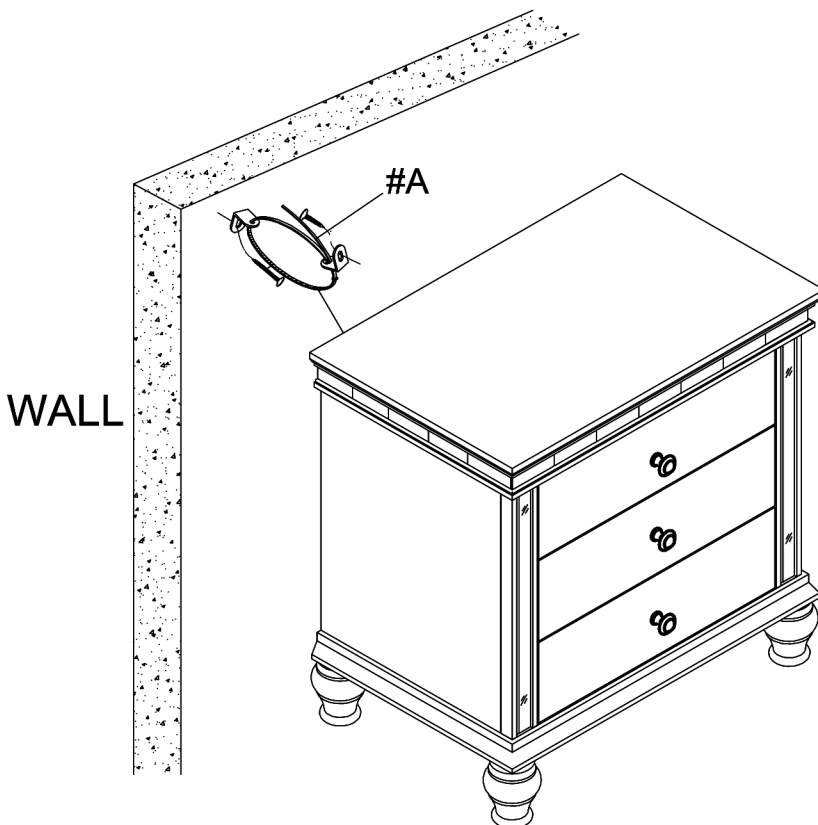

## ASSEMBLY COMPLETED



Please ensure the furniture rests on an even and flat surface. If the product wobbles or feels loose, double-check all bolts and/or screws are properly tightened and secured.

### ✓ Keep this handy!

Please retain this instruction manual and any order-related information for future reference.

### ✓ Lift, don't drag!

To avoid damage to product please always LIFT the product when transporting or adjusting the placement.

# ASSEMBLY INSTRUCTIONS

## Wall Mounting and Fixing

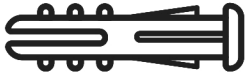

### EXPANSION WALL ANCHOR

Our provided expansion wall anchors are only suitable for masonry walls, such as drywall, plaster or concrete, and are best for holding lightweight items or for anti-tip prevention. If you are unsure of the correct wall anchor to use with the product, please request professional guidance. Liability for product damage or failure due to using the incorrect anchors will fall on the installer.

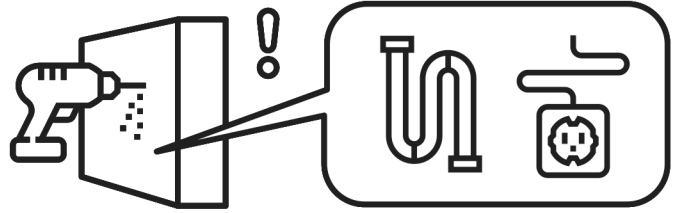

### CHECK BEFORE PROCEEDING

Prior to drilling or hammering, please check for wires or pipes. We recommend using a stud finder to locate a stud, which will offer more appropriate resistance and hold more weight.

## QUICK TIPS

1. If unsure of the proper size, always choose a larger screw and wall anchor.

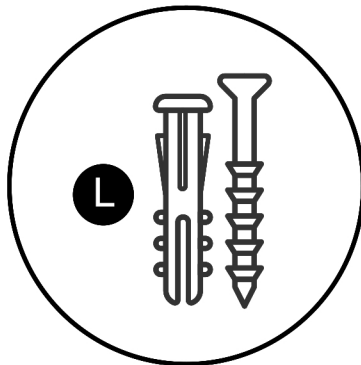

2. Match the drill bit to the wall anchor and hole size.

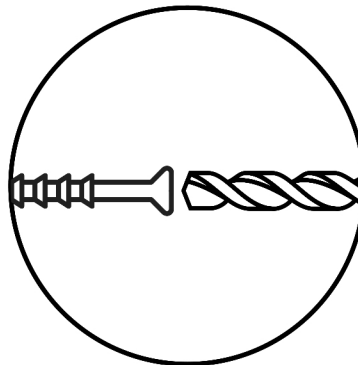

3. Only drill horizontally. Do not force the drill or enlarge the hole for the wall anchor.

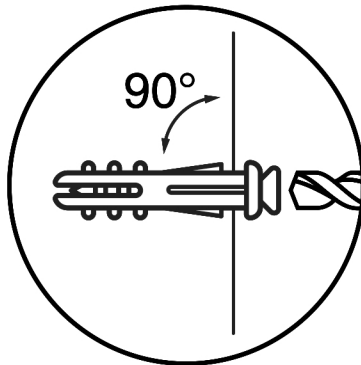

4. Take extra care when drilling into high walls or ceramic tiles. Wall anchors should be a tight fit for the hole. Never use wall anchors in ceilings.

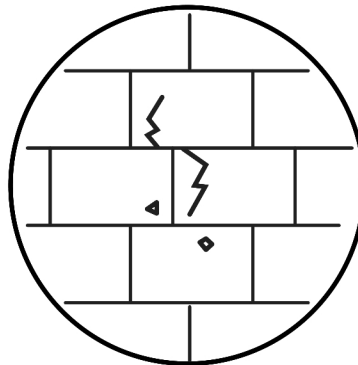

### MAINTENANCE

Yearly Check

We recommend a yearly check to see if the wall anchor or screw has loosened. If so, please remove the existing wall anchor and screw, and use a new anchor.