

4 - Drawer Chest

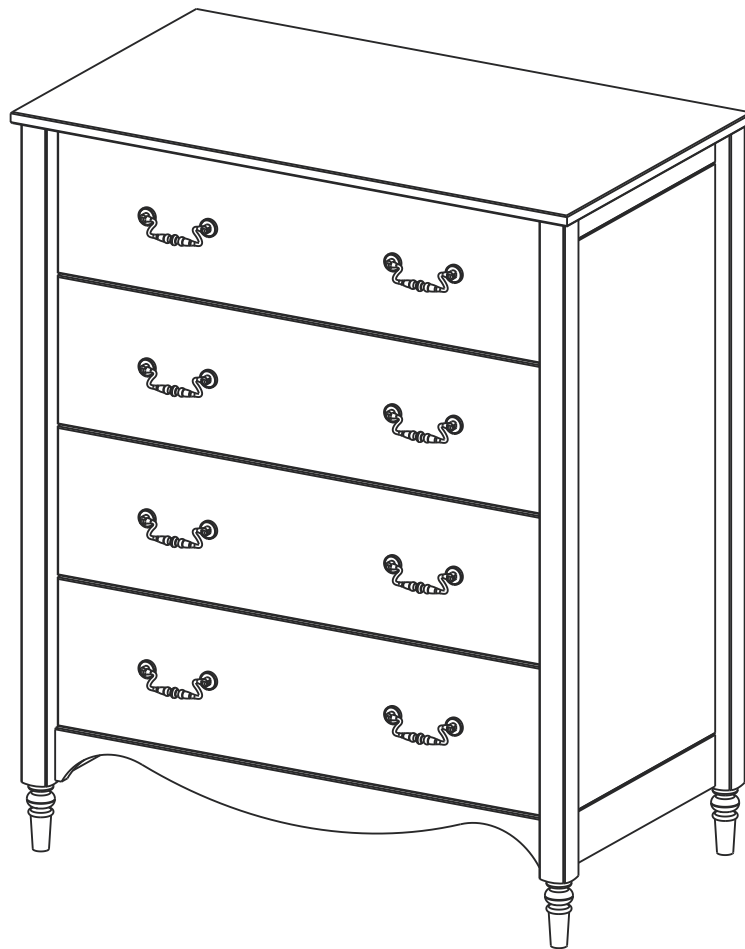

For Residential Use Only

Time to get started

Set up a clean and soft workplace to avoid damage during assembly. You can use the box and internal protections as a cover. It also helps to double-check if you have got all the pieces and parts before diving into the assembly.

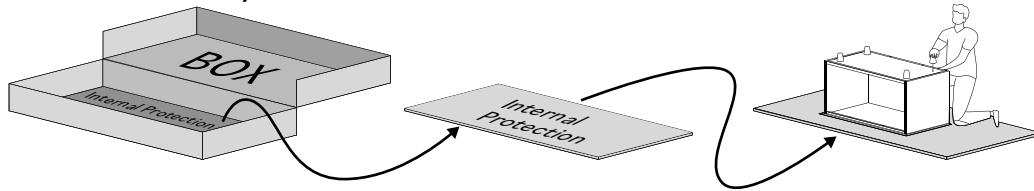

**Estimated time
for assembly**

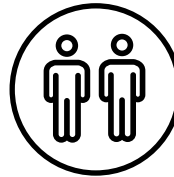

2 People Build

**People recommended
for assembly**

Make it a team effort!
Grab a friend for quicker,
easier assembly.

Tools Needed

Grab a Phillips head screwdriver and a hammer to conquer this assembly. We will also need a hammer to help.

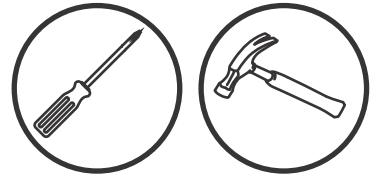

Use power tools with caution

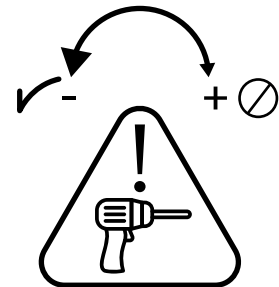

This furniture is made of Solid Wood and Composite Wood, soft materials. If you choose to use power tools, set it to the slower setting. Be careful! Power tools can cause cracking or damage to the furniture, they can also damage the hardware if misused.



Parts List







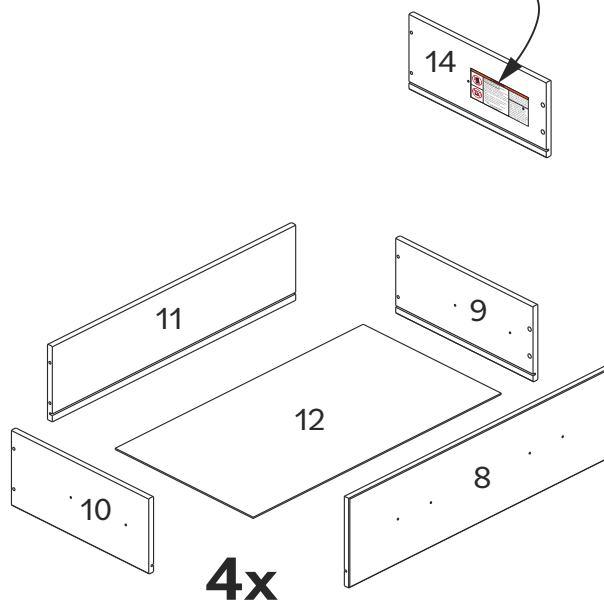
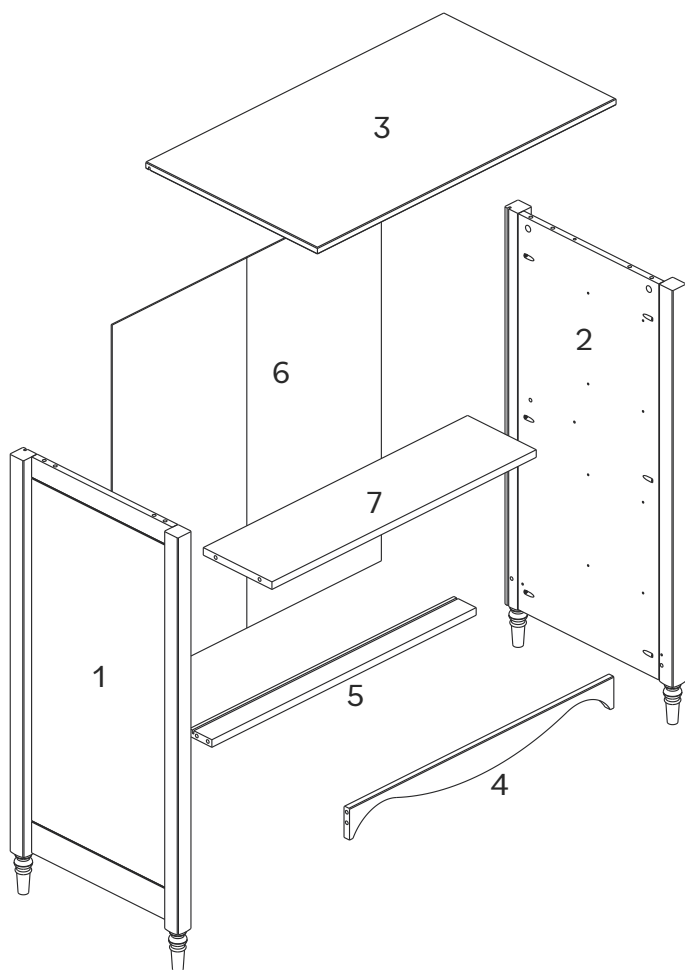









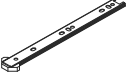

Part Number	Description	Quantity
1	Left Panel	1
2	Right Panel	1
3	Top Panel	1
4	Front Rail	1
5	Back Rail	1
6	Back Panel	1
7	Center Rail	1
8	Drawer Front	4
9	Right Drawer Side	3
10	Left Drawer Side	4
11	Drawer Back	4
12	Drawer Bottom	4
14	Right Drawer Side With Warning	1

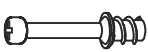
The drawer side with the **WARNING LABEL**, should be placed as the highest drawer.

⚠ WARNING		
	Children have died from furniture tipover. To reduce the risk of furniture tipover: <ul style="list-style-type: none"> -ALWAYS install anti tip device provided. -NEVER put a TV on this product. -NEVER allow children to stand, climb or hang on any drawers, doors, or shelves. -NEVER open more than one drawer at a time. 	DO NOT remove the interlock system except for maintenance as shown. NEVER use the unit without the interlock installed following the instructions System Specific Instructions for Interlock Installation. Insert Interlock Lock on the sliders. After securing the sliders to the cabinet, attach the Interlock Bars to the Locks. Once this is done you can place the drawer one at a time. To remove the drawer push the locks in the sliders.
	 <ul style="list-style-type: none"> -DO NOT defeat or remove the drawer interlock system: it is an important stability and safety system. -Place heaviest items in the lowest drawers. <p><i>This is a permanent label. Do not remove!</i></p>	

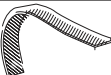

Hardware List

Part	Size	Name	Quantity
A		Dovetail	8
B		Dovetail Lock	16
C		Plastic Screw	16
D	 6x12mm	Screw	16
E		Interlock Lock	8
F	 6x14mm	Screw	16
G1	 250mm	Outer Slider	8
G2	 250mm	Inner Slider	8
H		Handle	8
I	 M4x19mm	Screw	16
J	 8x30mm	Wooden dowel	10
K	 6x31mm	Cam bolt	10
L	 15x11mm	Cam Lock	10
M		Interlock Bar	3
N		Wedge	12
O	 4x40mm	Screw	1
P		Wall anchor	1
Q	 4x16mm	Screw	1
R	 6x35mm	Plastic bush	1
S		Washer	2
U	 3,5X14mm	Screw	12

*The hardware quantities listed above are required for proper assembly.
Extra hardware pieces may be included.*

Introducing The Easy Assembly Drawer System

Say Goodbye to Assembly Hassle!

We understand that assembling drawers can be the most time-consuming and tedious part of putting together your new furniture. That's why we've developed the Easy Assembly Drawer System - to make the process easy!

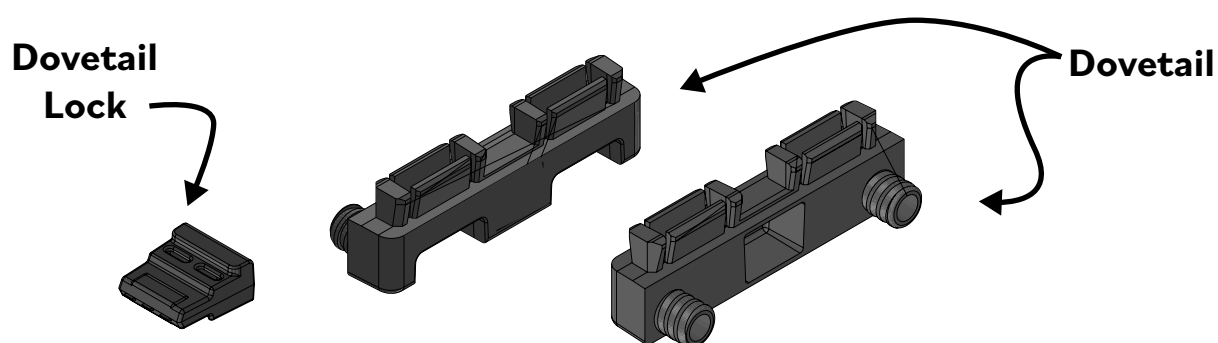

Why You'll Love Our Easy Assembly Drawer System:

Quick & Easy: Our new drawer hardware significantly reduces your assembly time. Get it done in no time!

Minimal Effort Required: Designed to be super simple, you'll need little to no tools to get the job done.

Built to Last: Strong and sturdy, our system ensures that your drawers stay solid and reliable.

Let's set the stage to assembly:

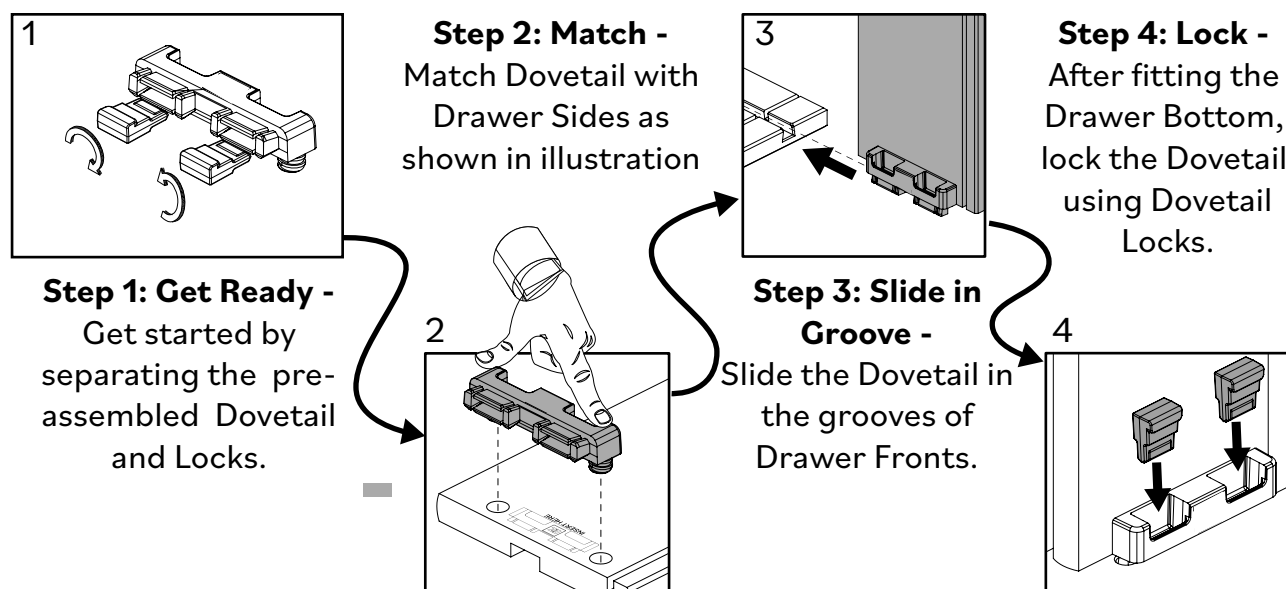

Attention: In the next steps there are more details to help you assemble.

Step 1

Prepare the Dovetails (A) by removing the Dovetail Locks (B) from the Dovetails (A).

1st

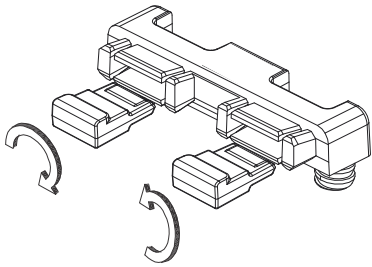

2nd

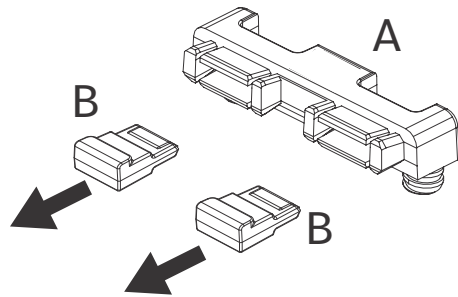

Step 2

Snap the Dovetails (A) into place on Right Drawer Sides (9 and 14) and Left Drawer Sides (10). Press the Dovetails until they are completely attached. Use a hammer if necessary.

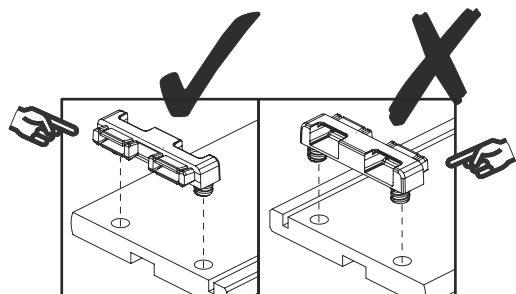

Press the piece until it is completely attached

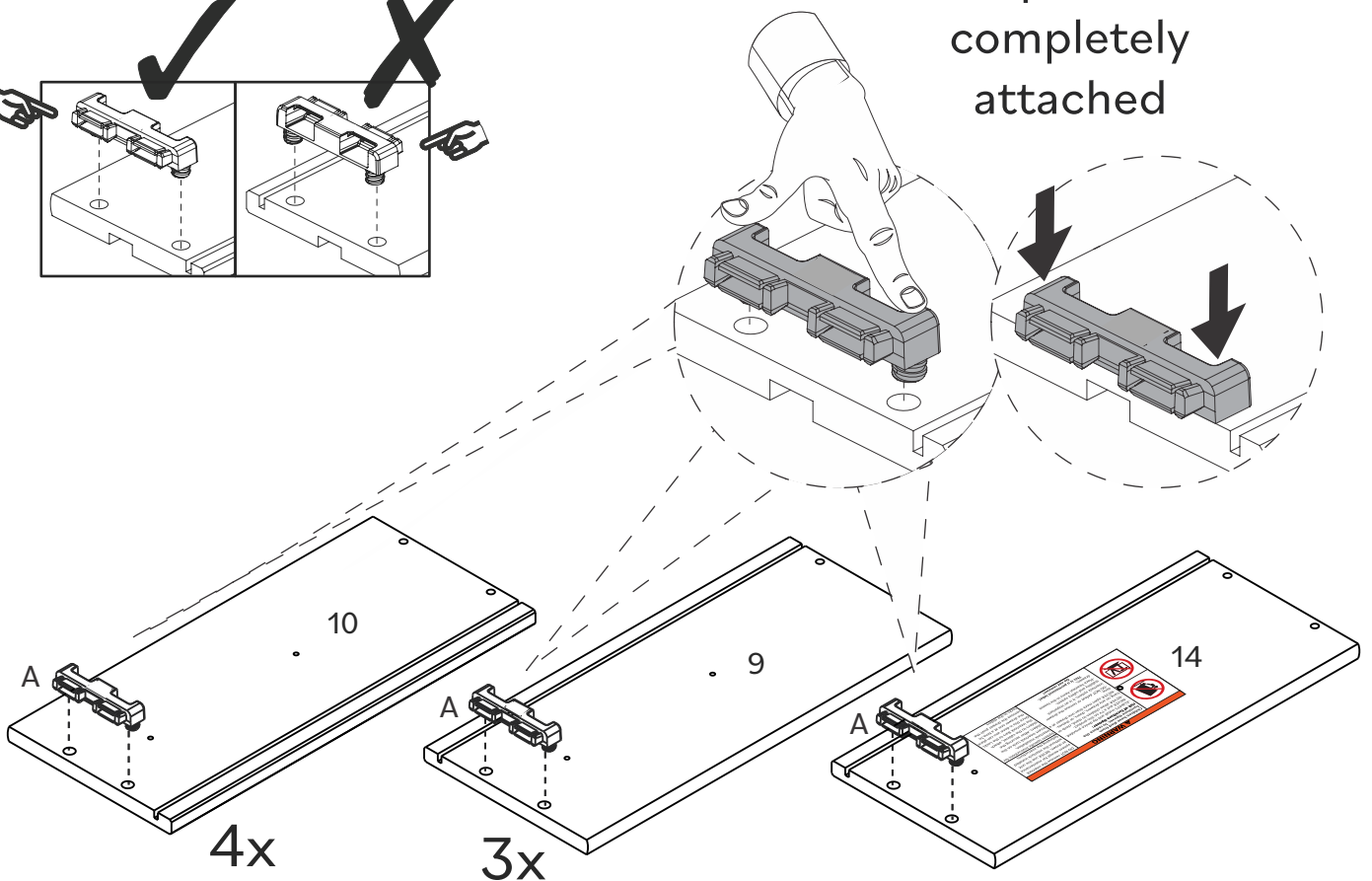

Step 3

Slide the Dovetail (A) on the Right Drawer Panel (9/14) and Left Drawer Panel (10) into the grooves on the Drawer Front (8).

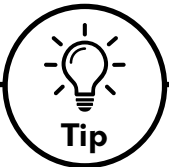
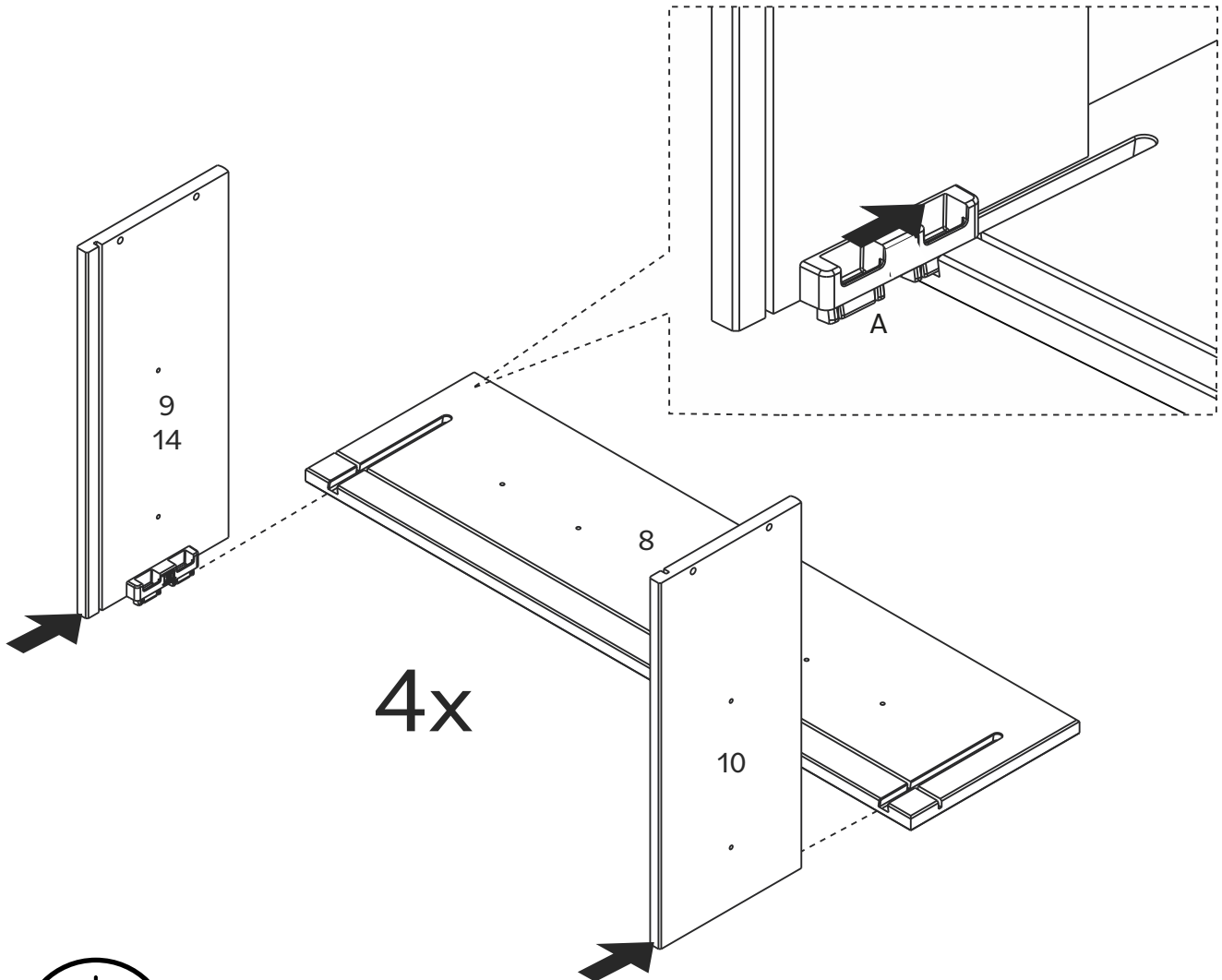

To keep your product looking its best and scratch-free, try assembling it on a soft surface like carpet or a blanket. This helps prevent any accidental scratches and keeps your furniture in top shape!

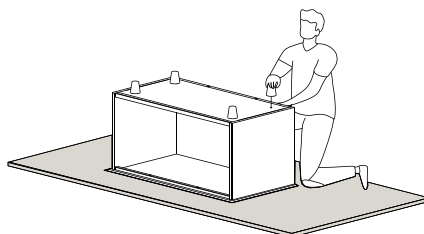

Step 4



Slide Drawer Bottom (12) between the grooves on Right Drawer Side (9 and 14) and Left Drawer Side (10) fitting in Drawer Front (8).

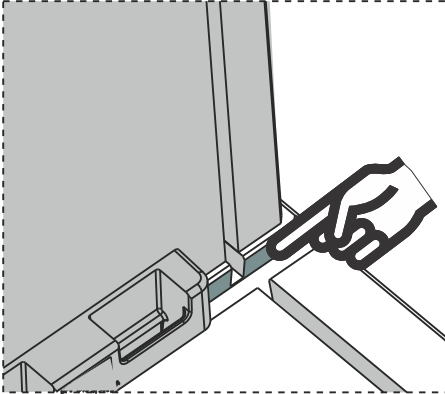

Align the grooves on the Drawer Sides and Drawer Front to receive the Drawer Bottom

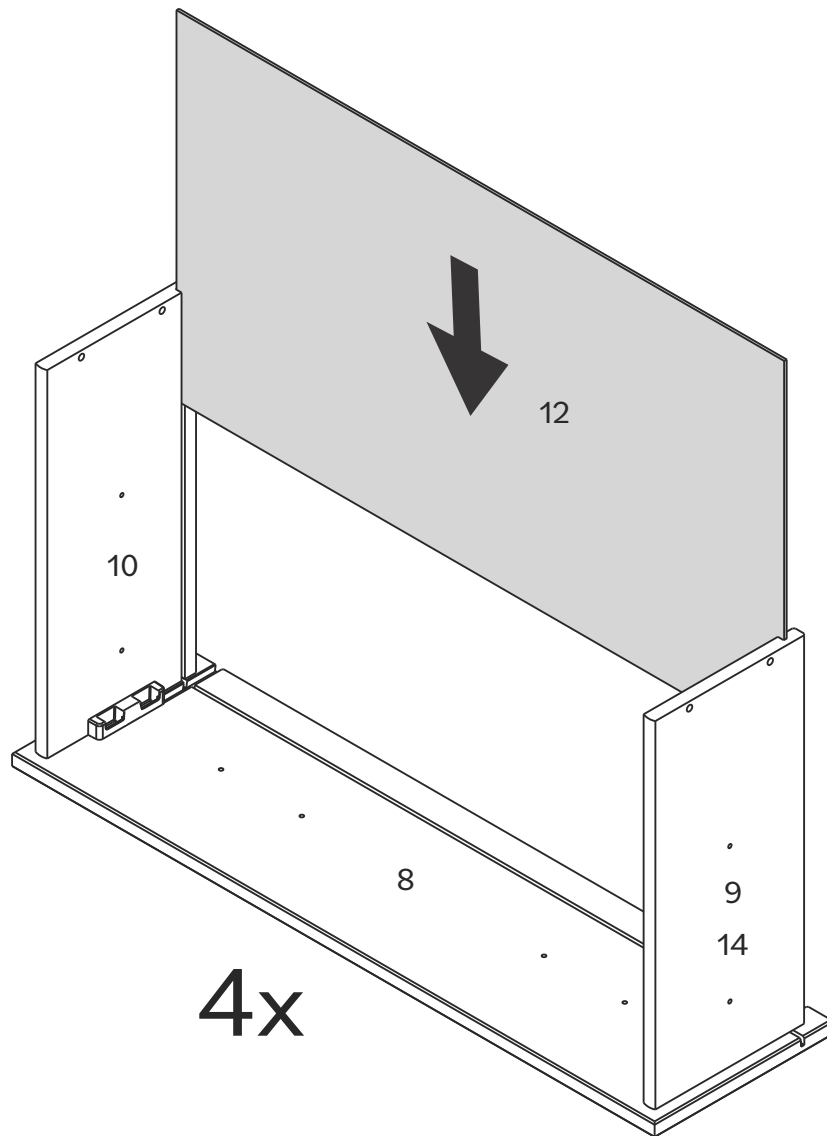

Step 5



To secure the Drawer sides, insert the Dovetail Locks (B) into the Dovetails (A). Use a hammer if necessary.

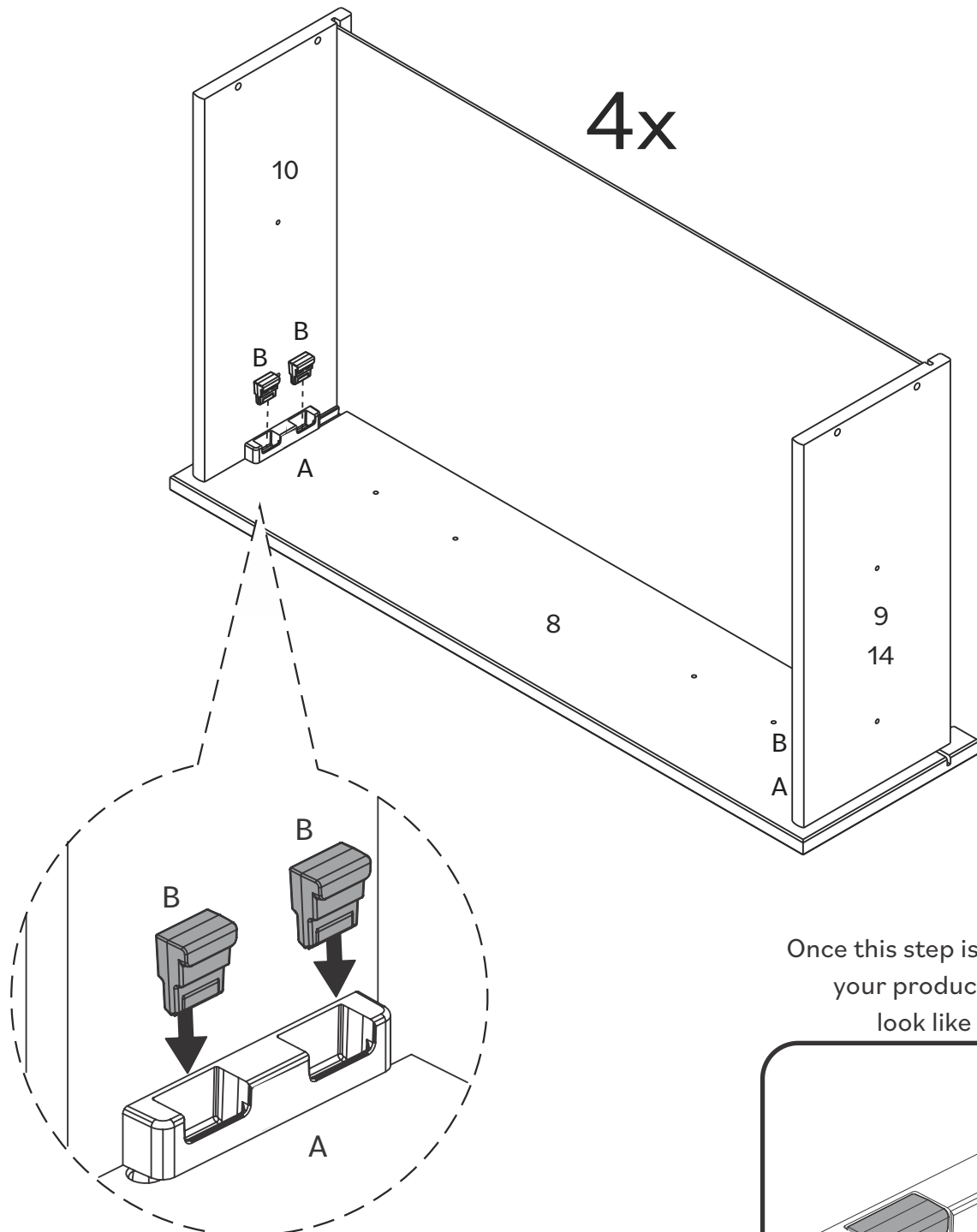

Once this step is completed, your product should look like this:

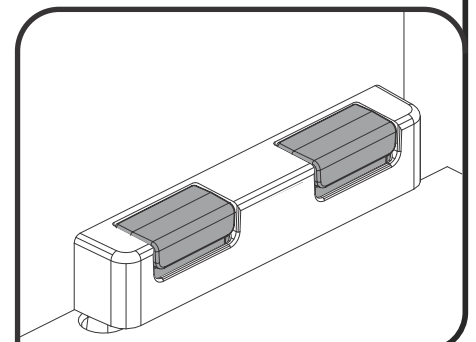

Step 6



Fit Drawer Bottom (12) to Drawer Back (11) and secure using Plastic Screw (C), you can insert it with your hands or using a hammer.

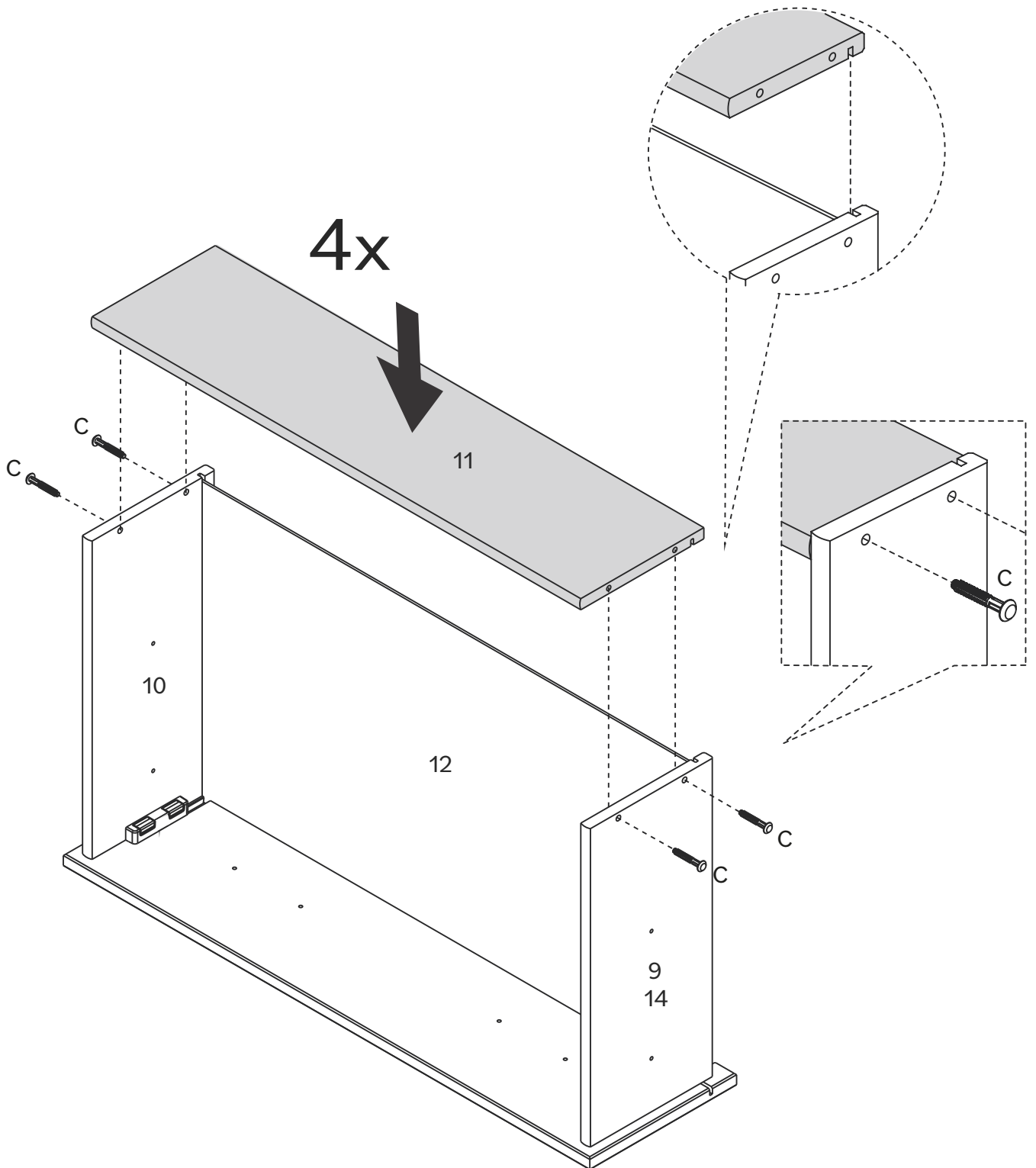

Step 7



Attach Inner Sliders (G2) to Right Drawer Sides (9 and 14) and Left Drawer Sides (10) using Screw (D) and a Phillips screwdriver.

Separate parts G1 and G2 by pressing the lock.

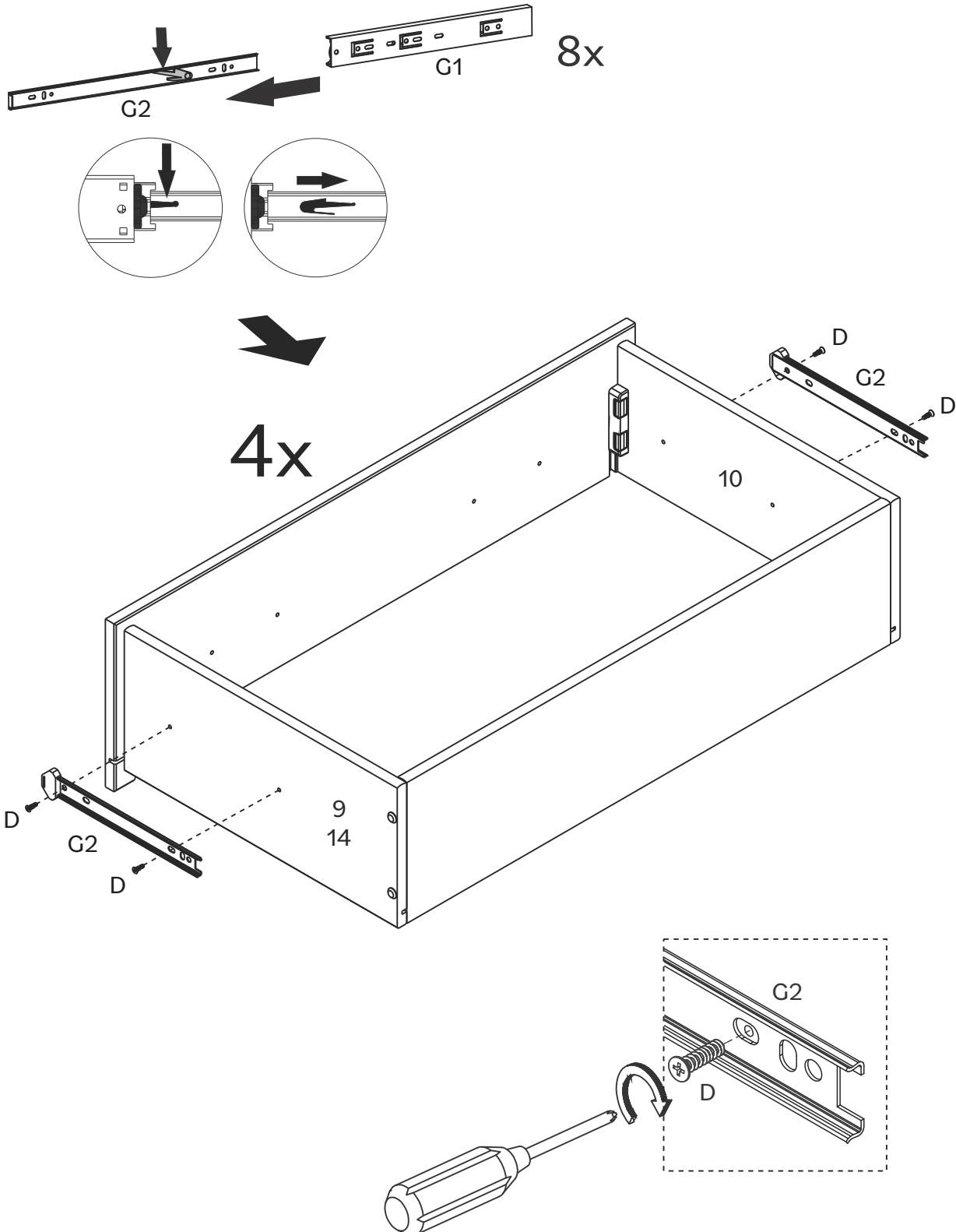

Step 8



Use Screws (I) and a Phillips screwdriver to secure Handles (H) to Drawer Fronts (8).

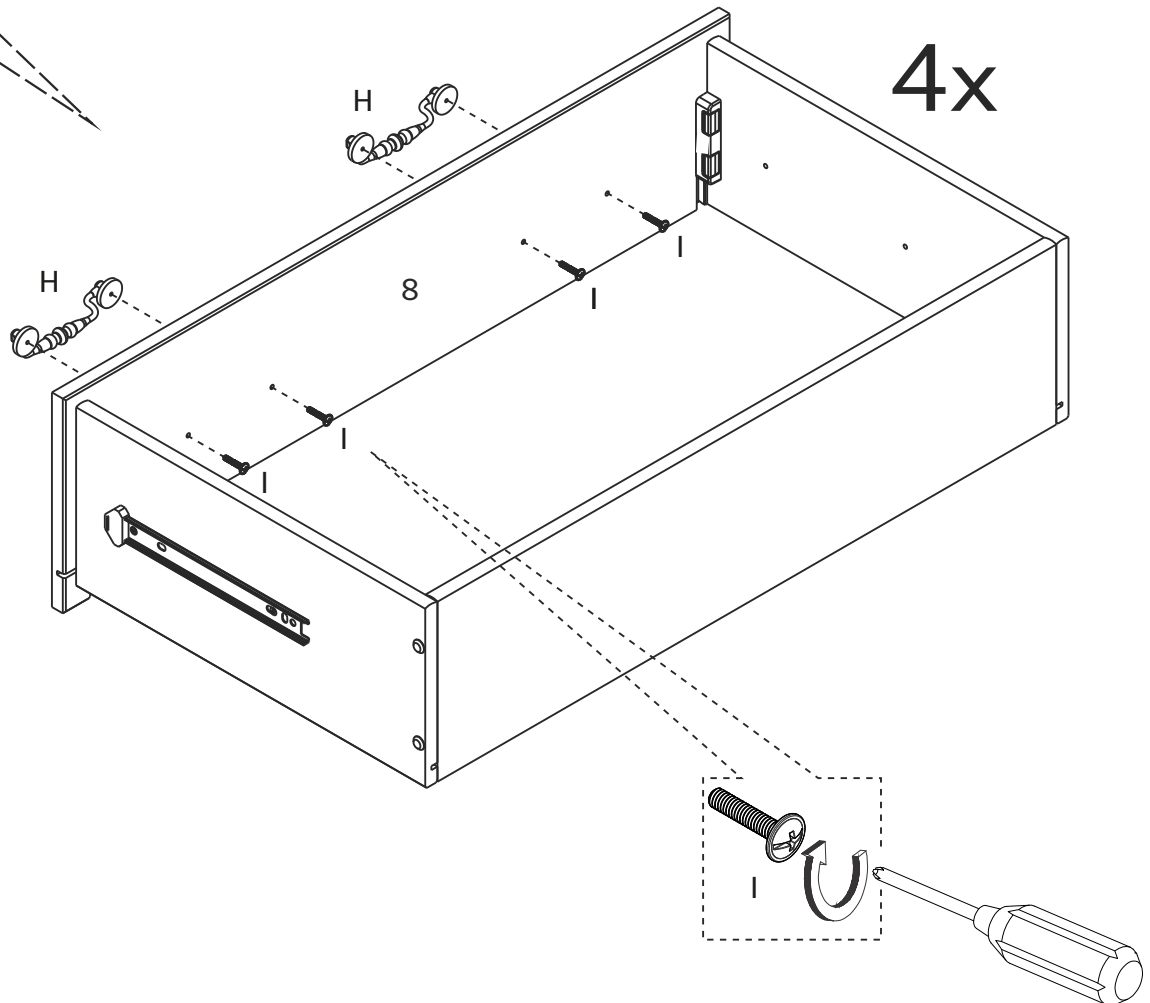
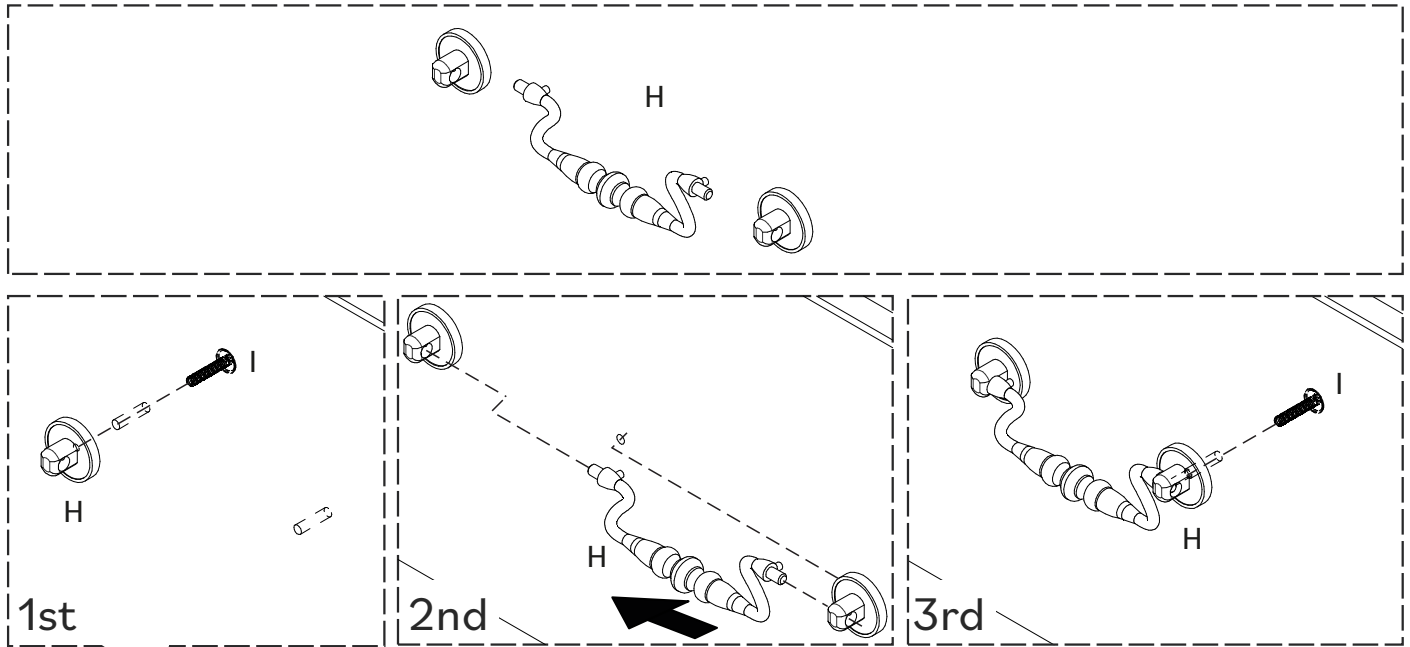

Step 9



Insert Wooden Dowels (J) into Left Panel (1), Right Panel (2), Front Rail (4), Back Rail (5) and Center Rail (7).

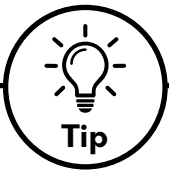
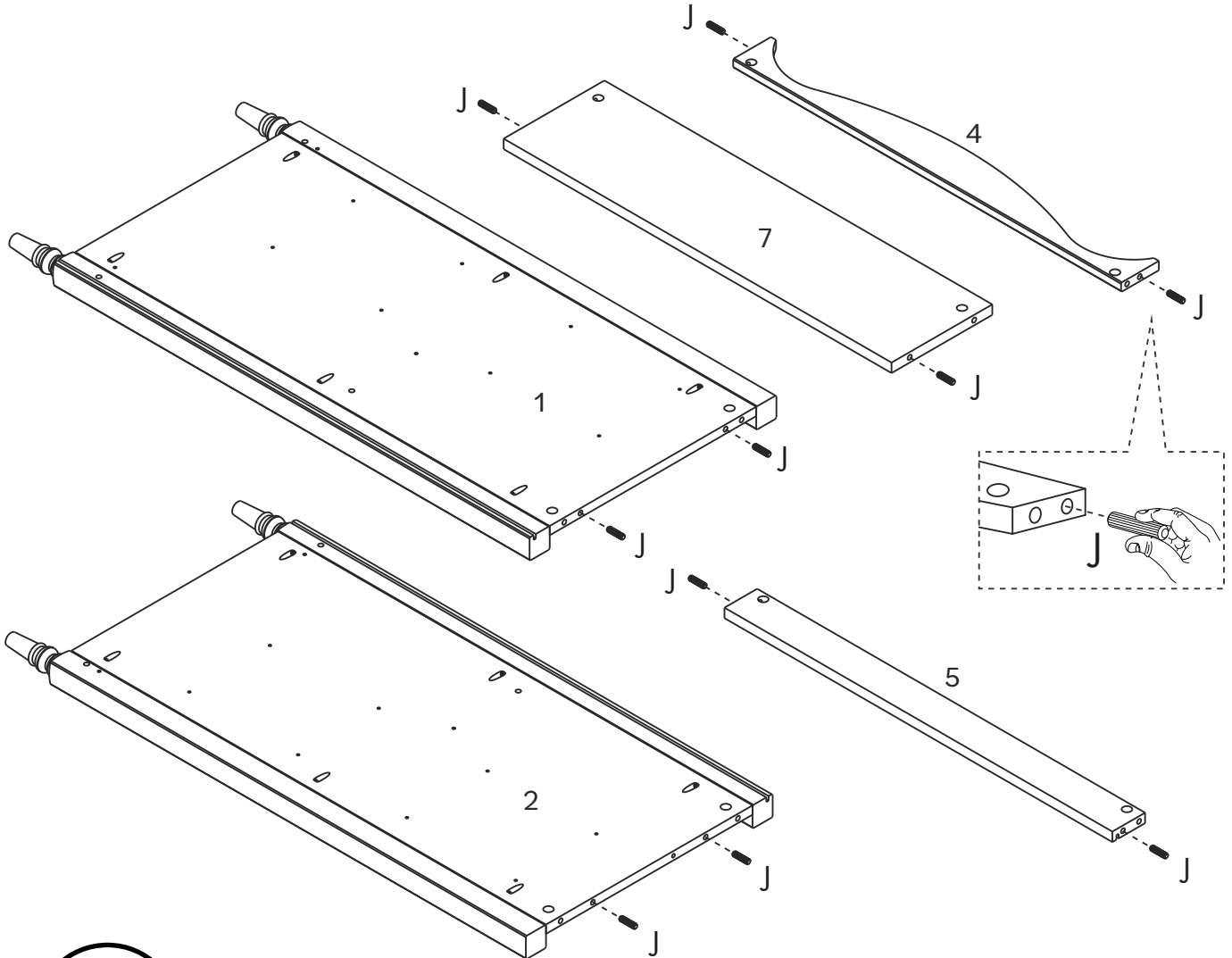

Tip

Wood Dowels

Dowels are essential in furniture assembly to create strong, precise connections. They ensure structural integrity, prevent shifting, and simplify alignment, resulting in sturdier, longer-lasting furniture.

Follow these steps:

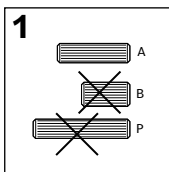

1: Select the appropriate size dowel according with step.

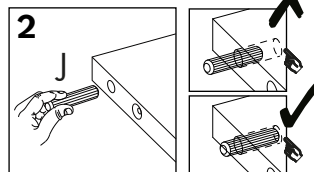

2: Insert into drilled hole and press firmly to ensure placement is set.

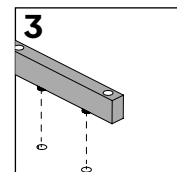

3: Align the dowel with corresponding piece and press together until secure.

Step 10

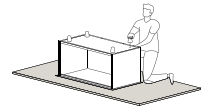

Attach Cam Bolts (K) to Left Panel (1), Right Panel (2) and Top Panel (3).

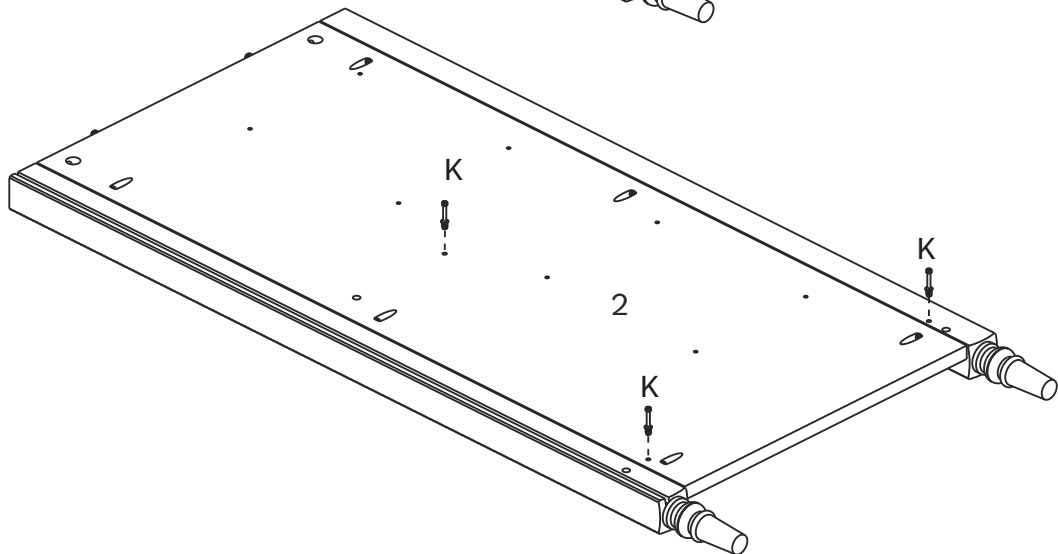
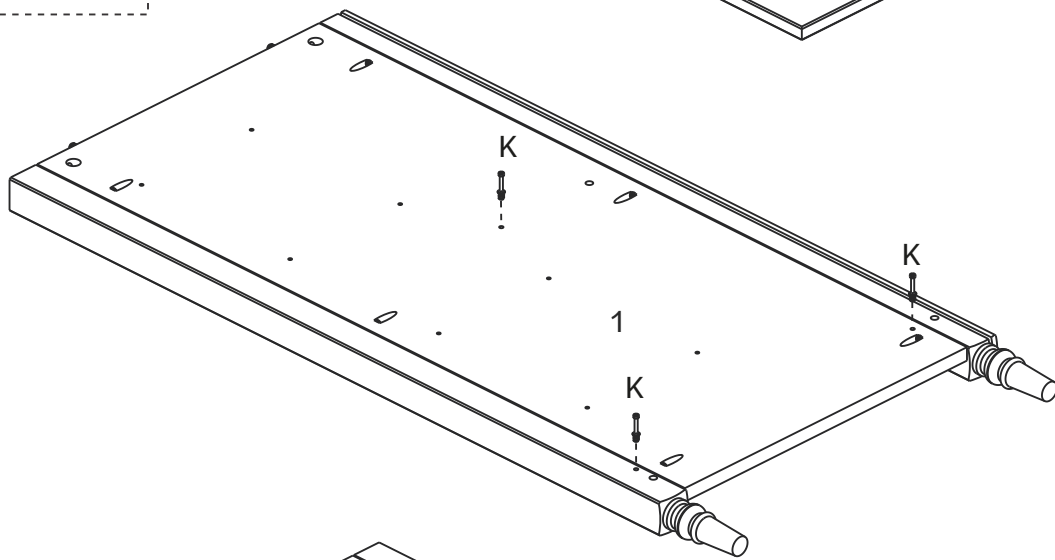
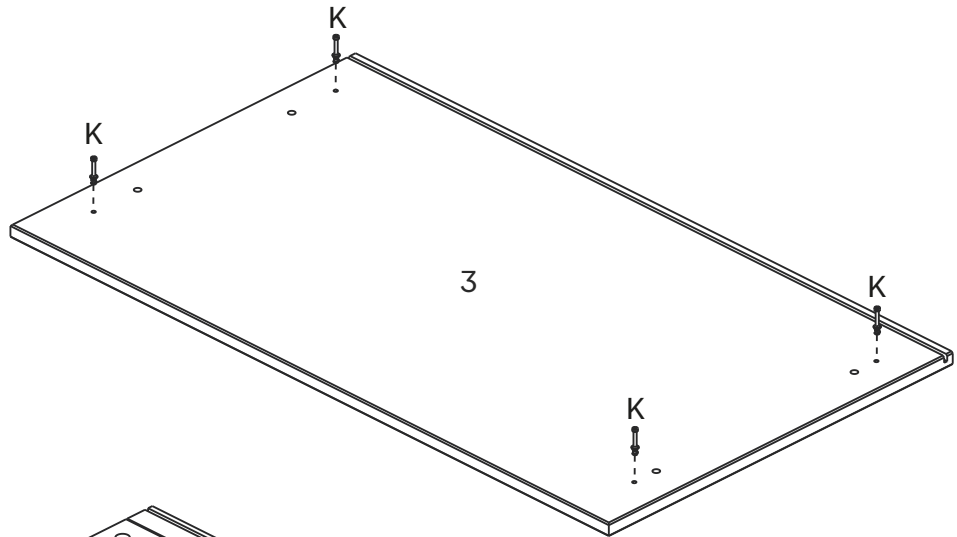
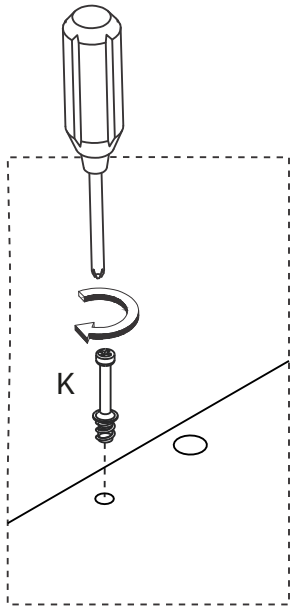

Step 11

Take Outer Slider (G1) and insert Interlock Lock (E) according to the diagram below.

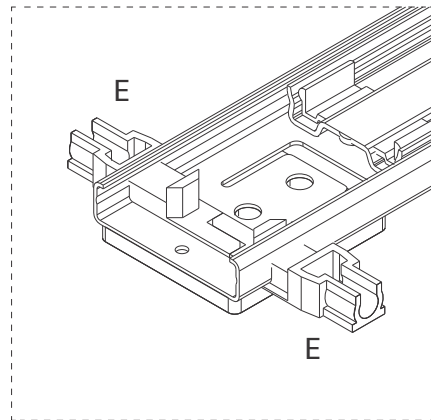
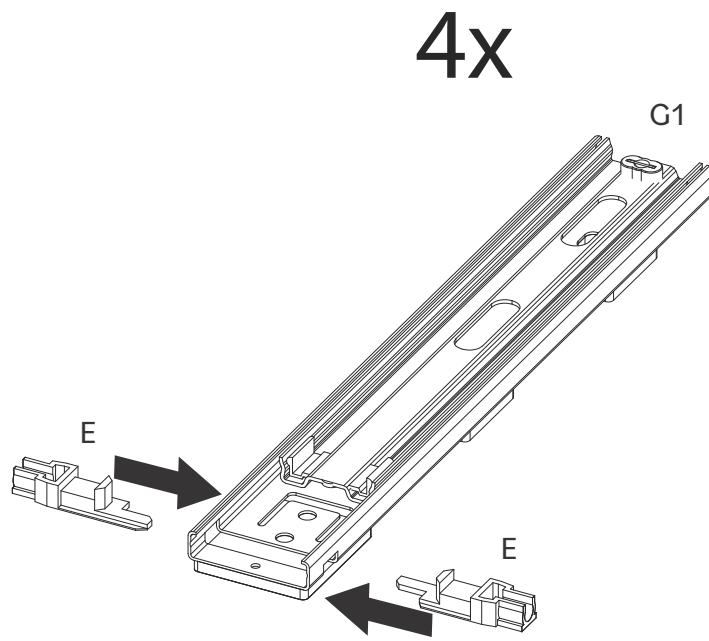

Step 12



Secure Outer Slider (G1) to Right Panel (2) and Left Panel (1) using Screw (F) and a Phillips screwdriver.

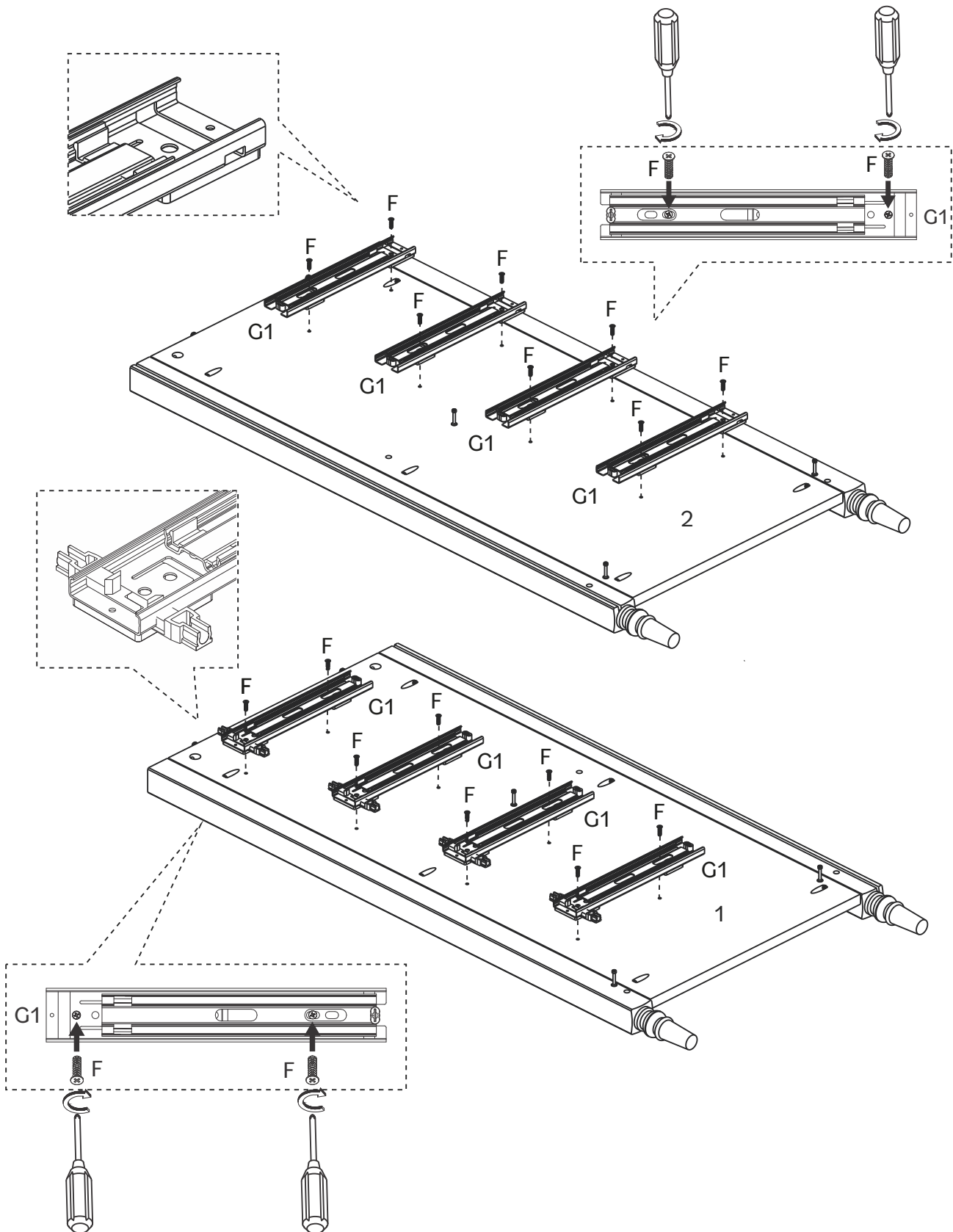

Step 13



Attach Front Rail (4), Back Rail (5) and Center Rail (7) to Left Panel (1) using Cam Lock (L) and a Phillips screwdriver.

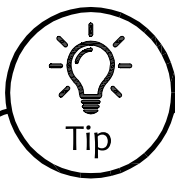
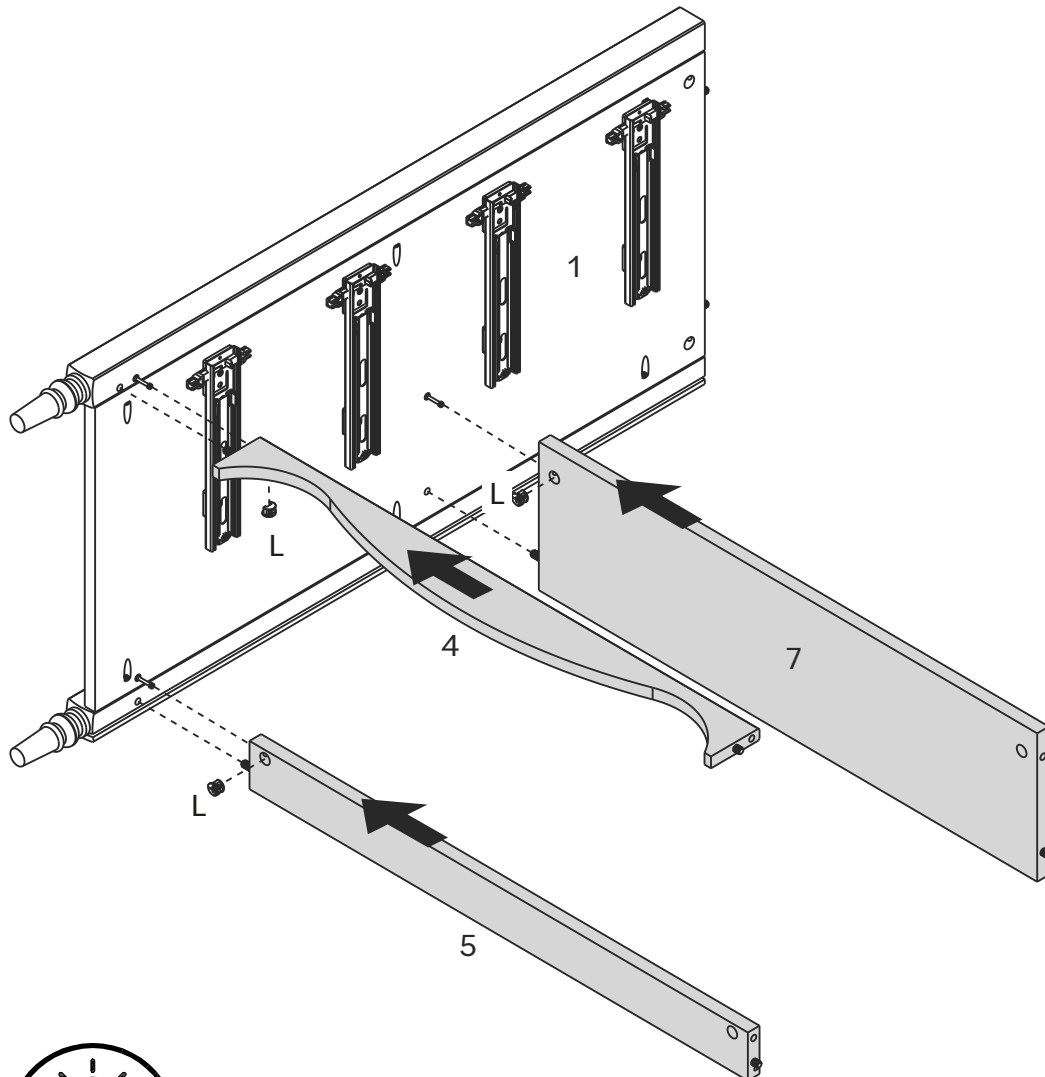

Tip

Cam Locks

Cam Locks help to securely join two pieces together. Follow these easy steps.

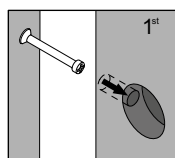

1: Insert Cam Bolt into bolt holes on the flat side. Don't over tighten!

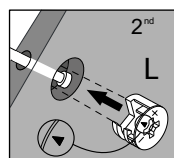

2: Assemble both parts together. The cam bolts goes in the drilled holes that have a circular hole on the side, you should be able to see the cam bolt through it. After fitting parts together insert the cam lock on the side holes.

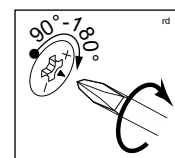

3: On the back of the Cam Lock will be a "C" shape. Insert the Cam Lock so the opening of the "C" fits over the Cam Bolt. Tighten with the screwdriver.

Step 14



Join Right Panel (2) to Front Rail (4), Back Rail (5) and Center Rail (7) using Cam Lock (L) and a Phillips screwdriver.

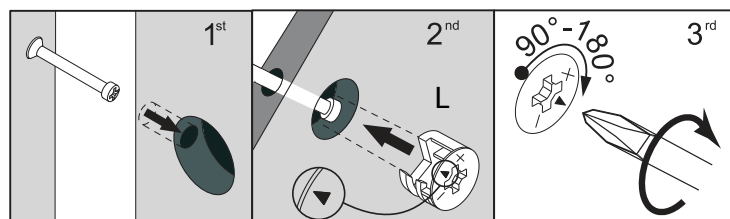
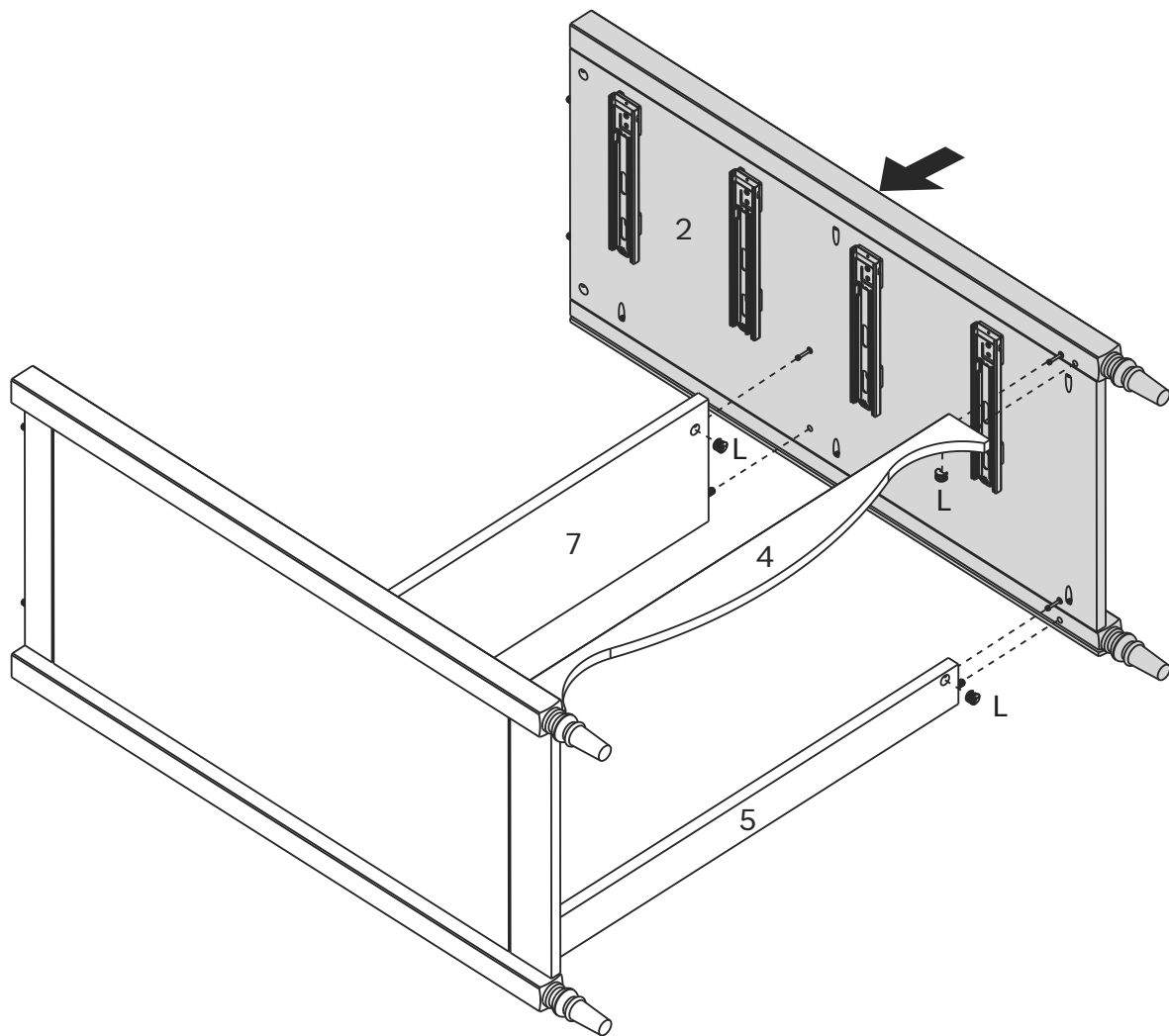

Step 15

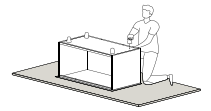

Slide Back Panel (6) on the grooves on Left Panel (1) and Right Panel (2), fitting in Back Rail (5).

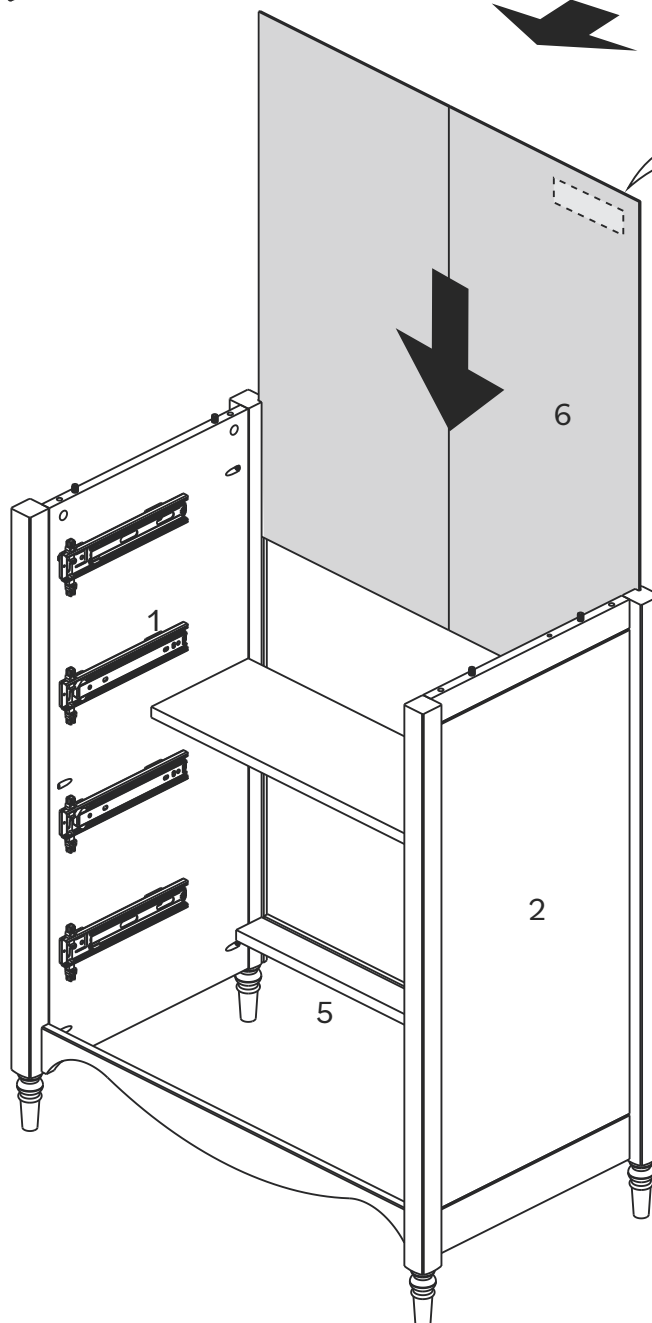

Traceability label
should be facing
outward

Name and address of
the supplier and date
of production.

Step 16



Secure Top Panel (3) to Left Panel (1) and Right Panel (2) using Cam Locks (L) and a Phillips screwdriver.

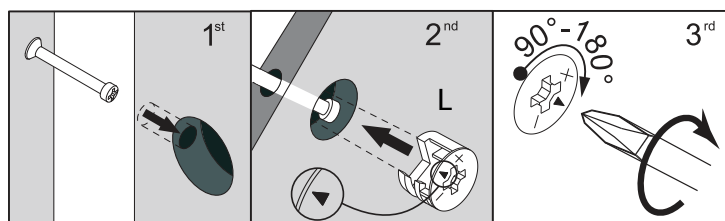
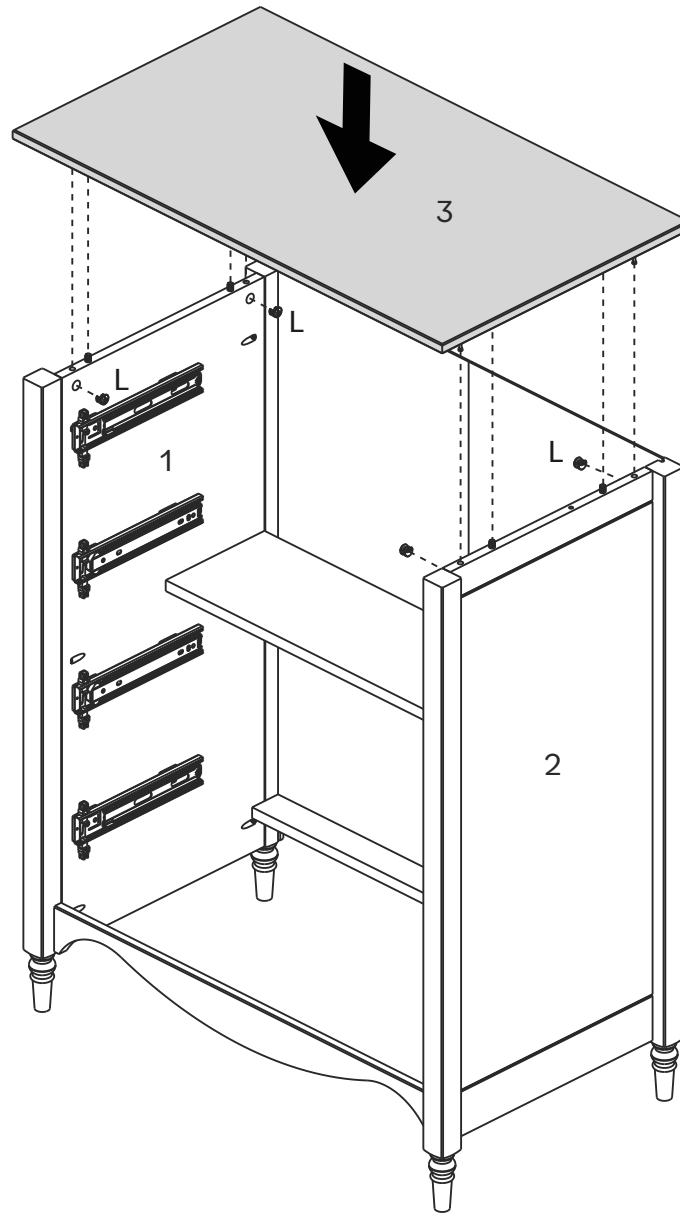

Step 17

Secure Back Panel (6) fitting Wedge (N) and screw (U) between the panel and the grooves. Use and a Phillips screwdriver.

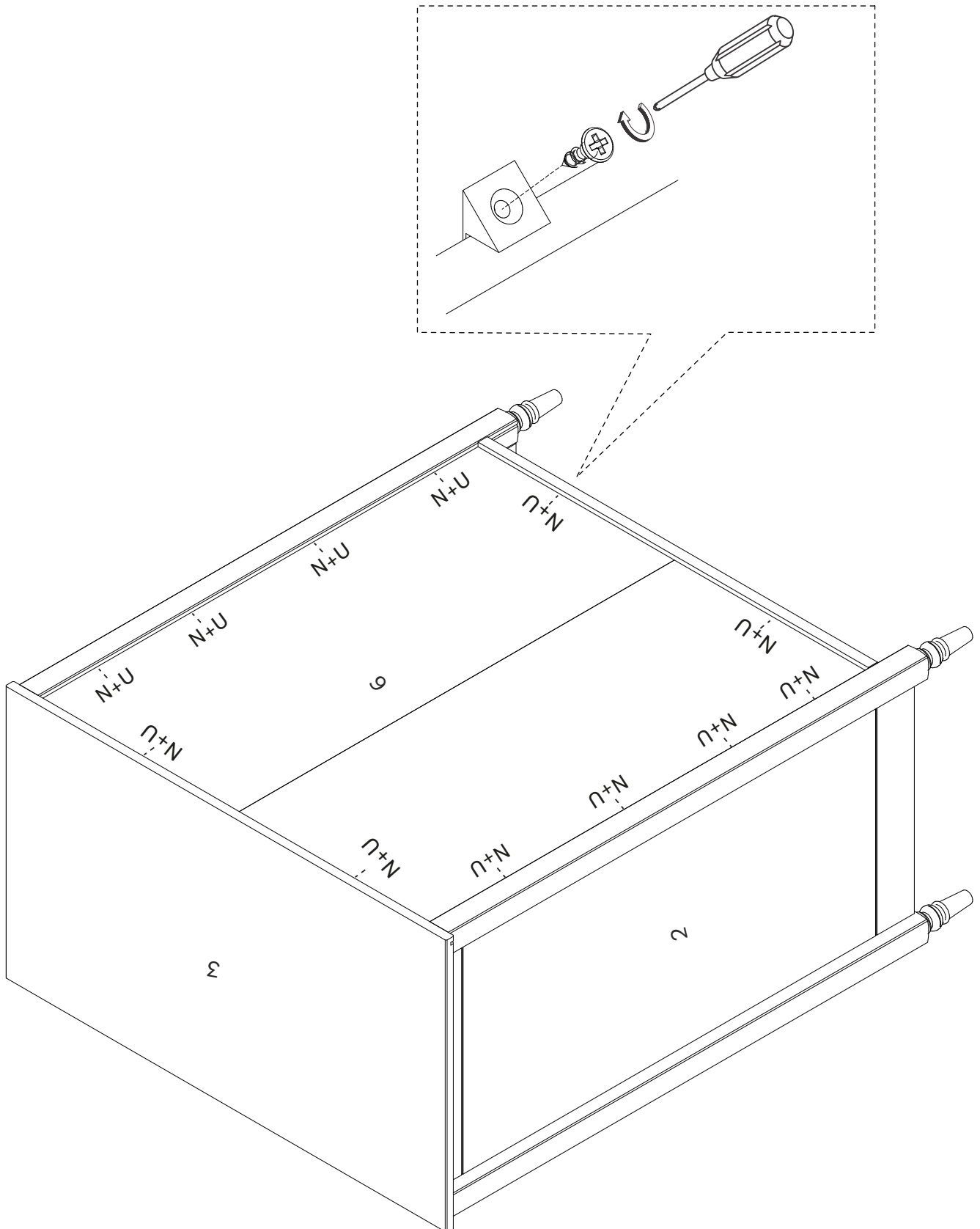

Step 18

Attach Interlock Bar (E) in the Locks (M).

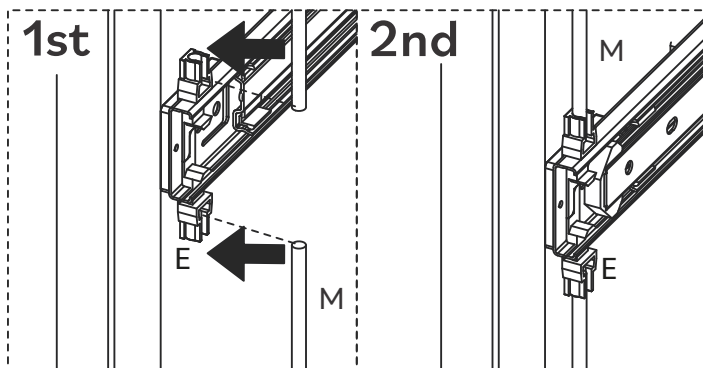
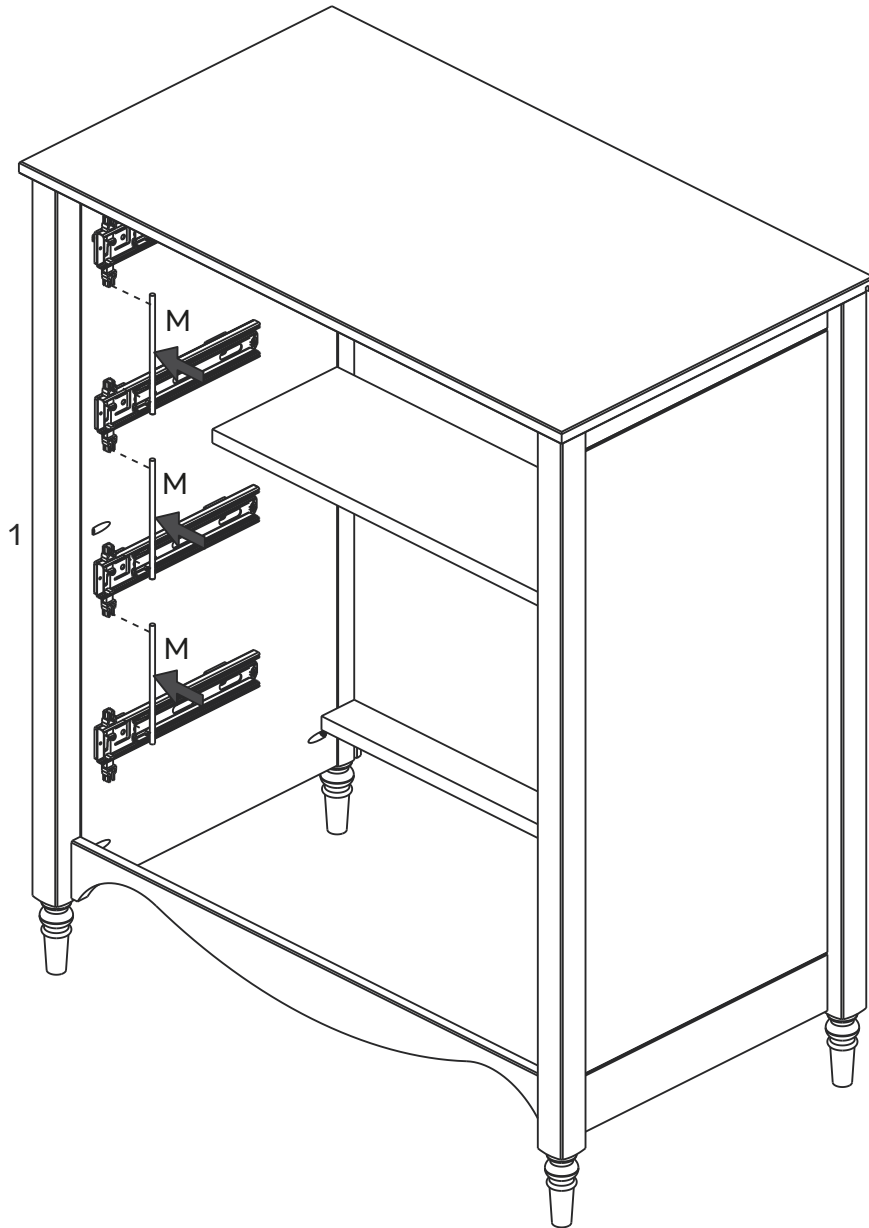

Step 19

Place the Drawers one at a time using the slider, pay attention to position them correctly aligning Outer and Inner Slider.

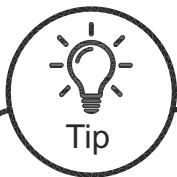
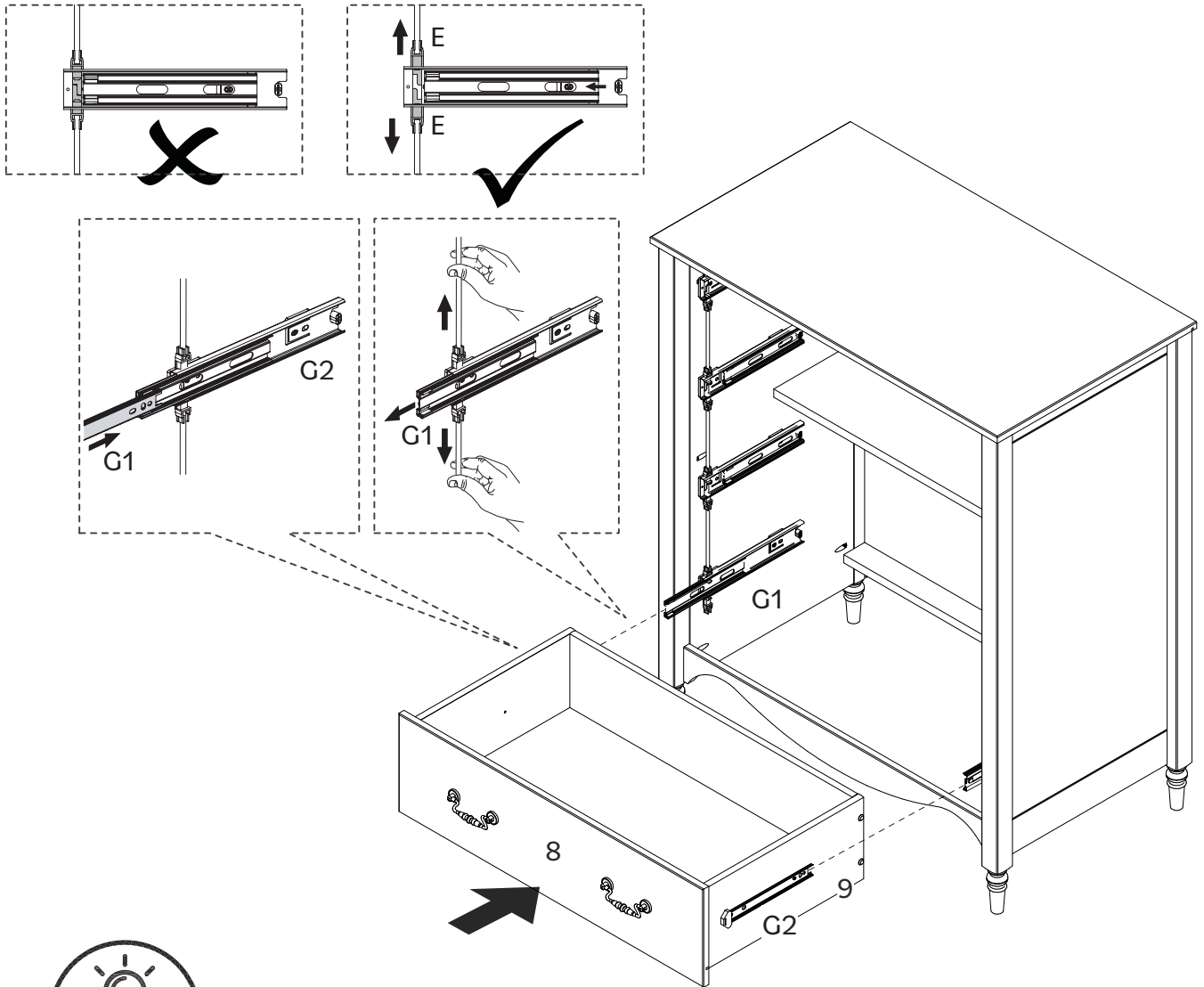

Tip

Insert your Cabinet Drawer Correctly

Line up Outer and Inner Slider and push the drawer slightly inside the unit, once you feel the connection push the drawer entirely into place. It may not be a smooth gliding at first, but it improves once fully connected.

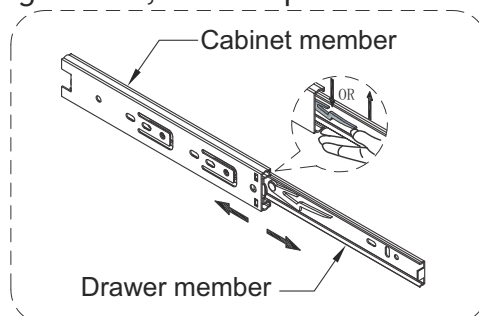

Step 20

Place the Drawers one at a time using the slider, pay attention to position them correctly aligning Outer and Inner Slider.

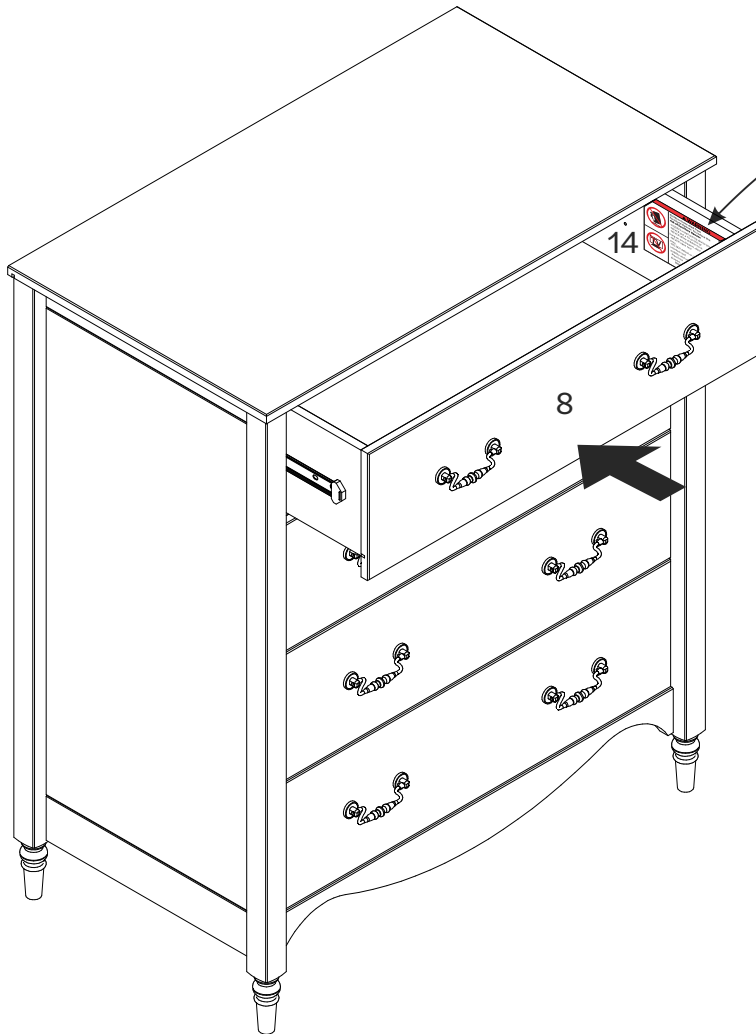

▲ WARNING	
 <p>Children have died from furniture tipover. To reduce the risk of furniture tipover:</p> <ul style="list-style-type: none"> -ALWAYS install anti tip device provided. -NEVER put a TV on this product. -NEVER allow children to stand, climb or hang on any drawers, doors, or shelves. -NEVER open more than one drawer at a time. -DO NOT defeat or remove the drawer interlock system; it is an important stability and safety system. -Place heaviest items in the lowest drawers. <p>This is a permanent label. Do not remove!</p>	<p>DO NOT remove the interlock system except for maintenance as shown. NEVER use the unit without the interlock installed following the instructions.</p> <p>System Specific Instructions for Interlock Installation. Insert Interlock Lock on the sliders. After securing the sliders to the cabinet, attach the Interlock Bars to the Locks. Once this is done you can place the drawer one at a time. To remove the drawer push the locks in the sliders.</p>

The Drawer Side with **Warning Label** should be positioned as the highest drawer.

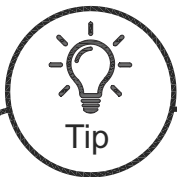
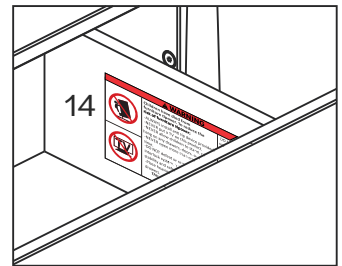

Removing the Drawer

There is a white lever in each slider, to remove the drawers pull the drawer out until you see the lever. Push one lever up and the other down, while pushing, bring the drawer out

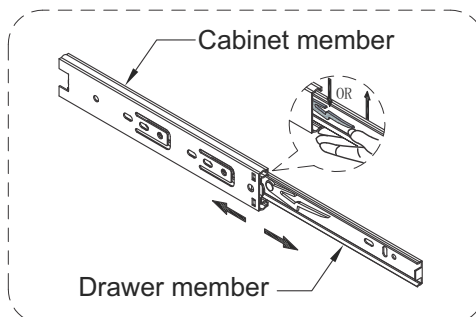

Step 21

To finish this up, attach the anti-tipping kit. Secure Wall Anchor (S) to Top Panel (3) using Washer (S), Screw (Q) and a Phillips screwdriver following the details in the diagram below.

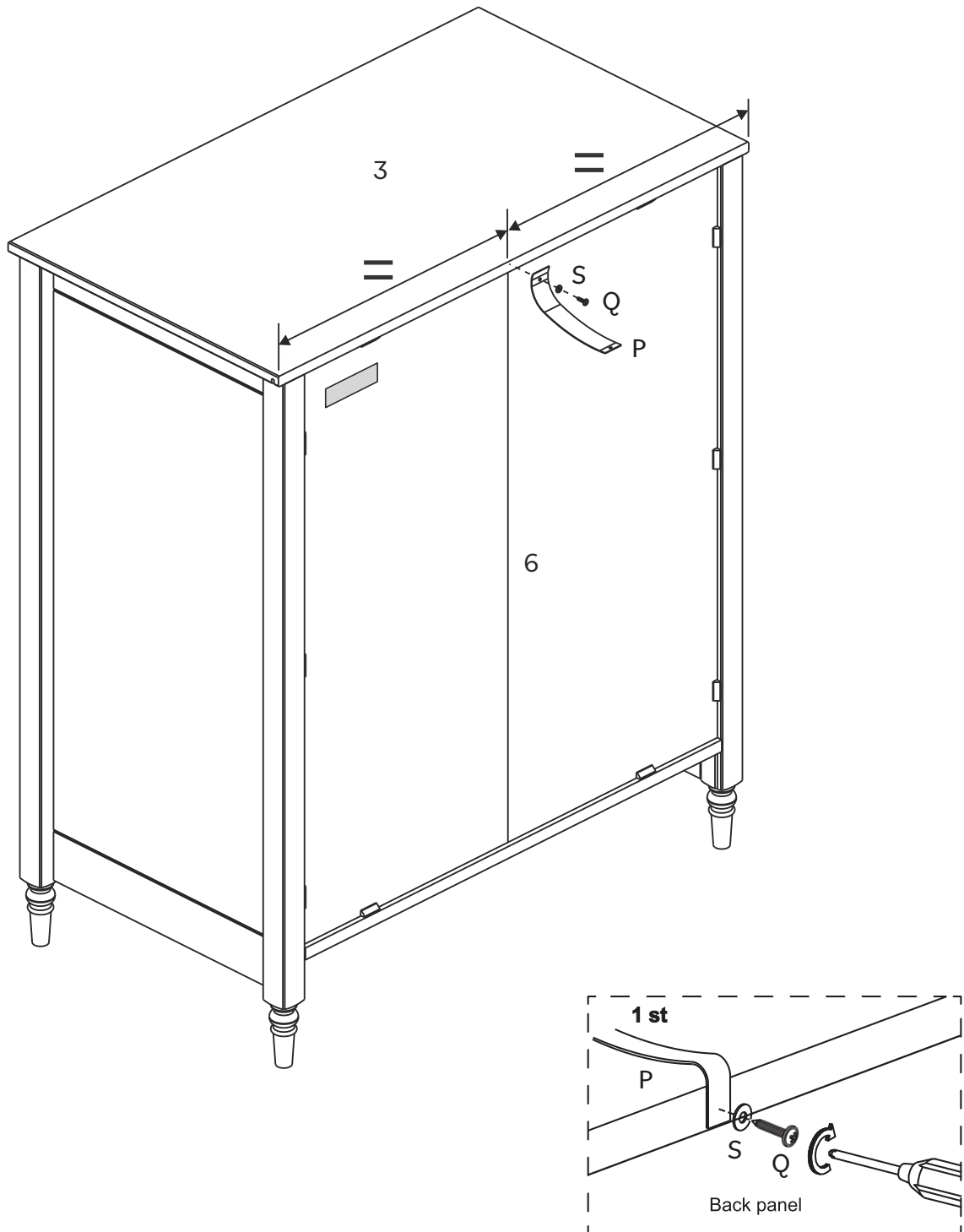

Step 22

Last step! Insert Plastic Bush (R) into the wall. Then, secure Wall Anchor (P) to the wall using Washer (S) and Screw (O).

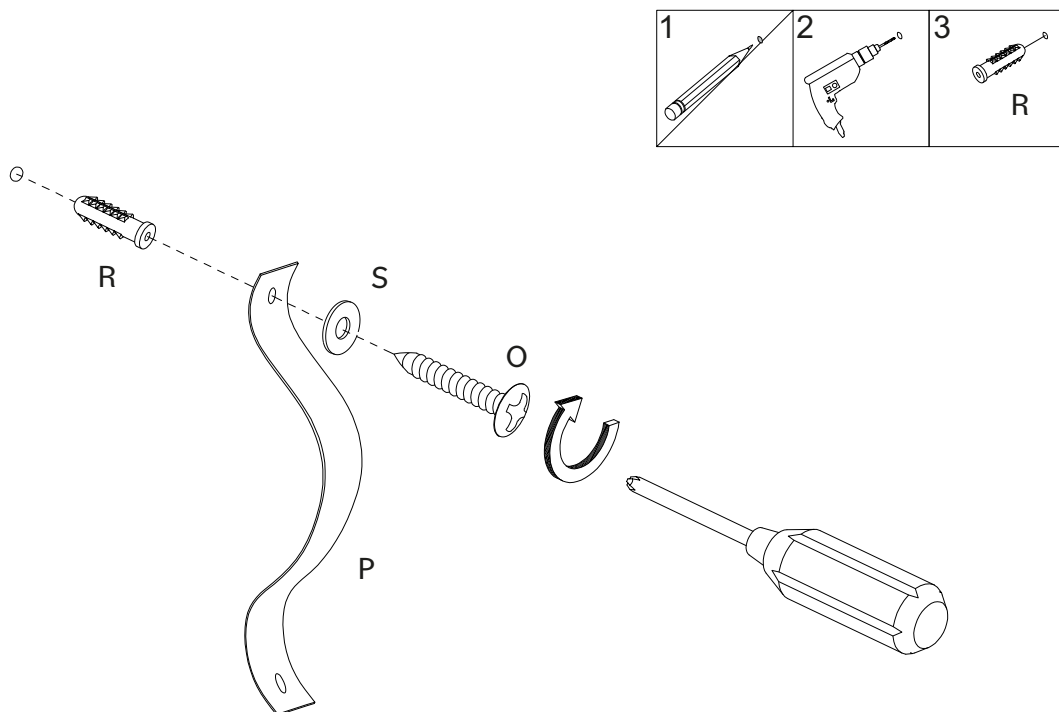

Warning

Serious or fatal injuries can occur from furniture tipping over. To prevent the furniture from tipping over we recommend that it is permanently xed to the wall. Wall anchor and hardware are included with this product. Please make sure hardware is suitable for your walls before installing, as diierent wall materials may require diierent types of anchors.

Name and address information for the manufacturer responsible for the anti-tip hardware and date of production can be found on the label on the back of the furniture.

To Disassemble



If it is necessary to disassemble, remove the Dovetail locker (B) with a Slotted head screwdriver.

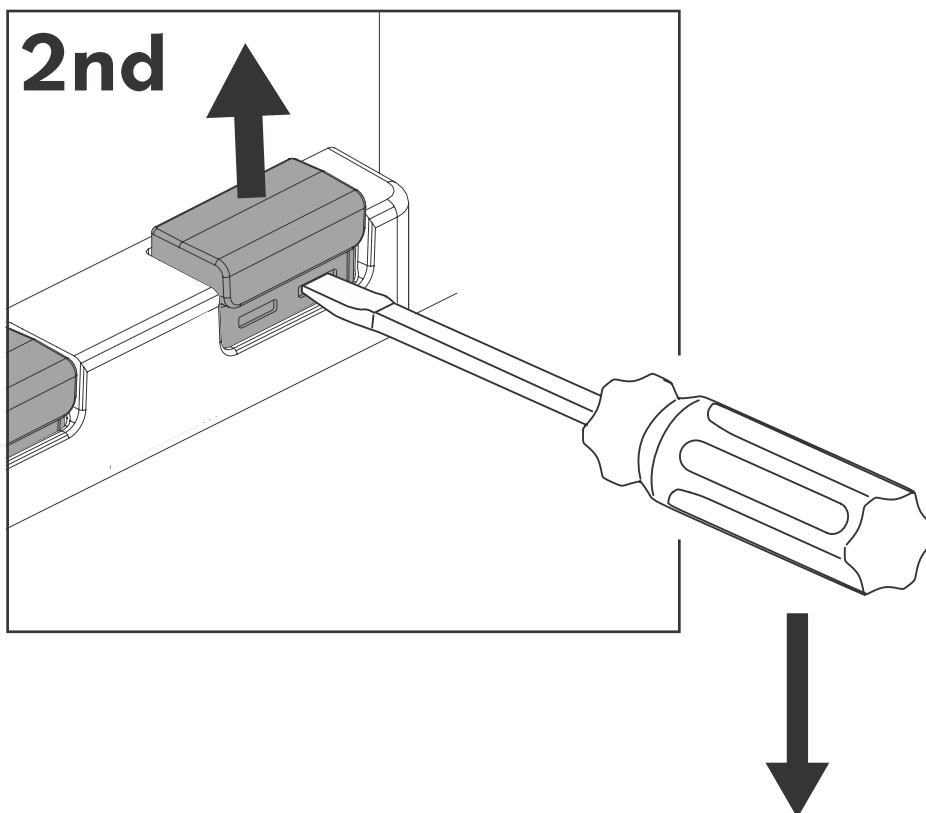
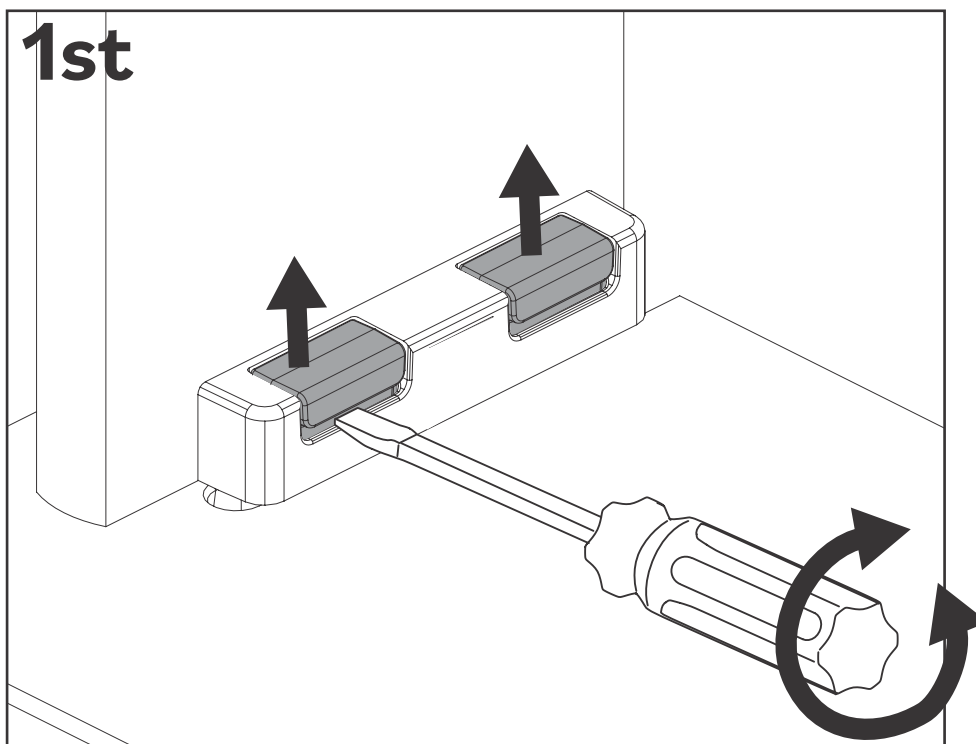

You did it! Enjoy your new Drawer Chest!

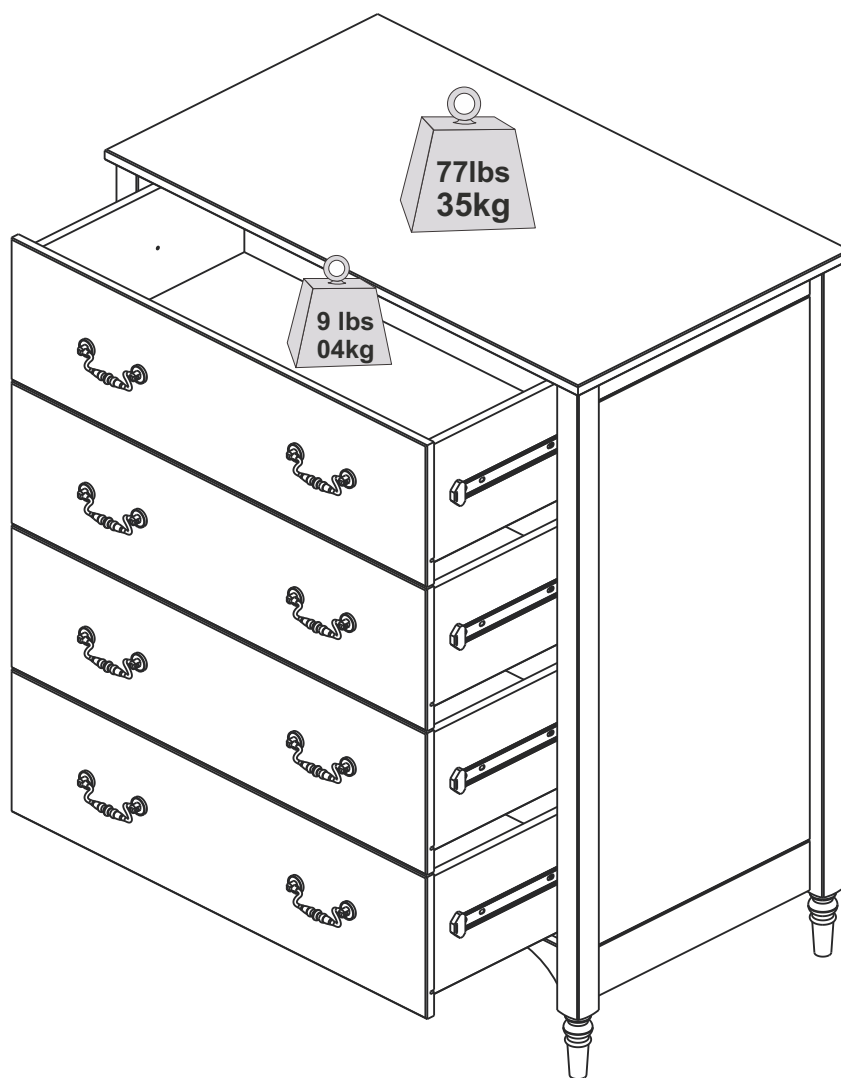

Congratulations on your new piece of furniture!

5 Commode à tiroirs
5 Cómoda con cajones



Pour usage résidentiel seulement

Sólo para uso residencial

Il est temps de commencer / Hora de empezar

Prépare un lieu de travail propre et souple pour éviter tout dommage lors de l'assemblage. Tu peux utiliser la boîte et les protections internes comme base. Vérifie également que tu disposes de toutes les pièces et parties avant de te lancer dans l'assemblage.

Prepárate un lugar de trabajo limpio y blando para evitar daños durante el montaje. Puede utilizar la caja y las protecciones internas como base. Comprueba también que tiene todas las piezas y partes antes de sumergirse en el montaje.

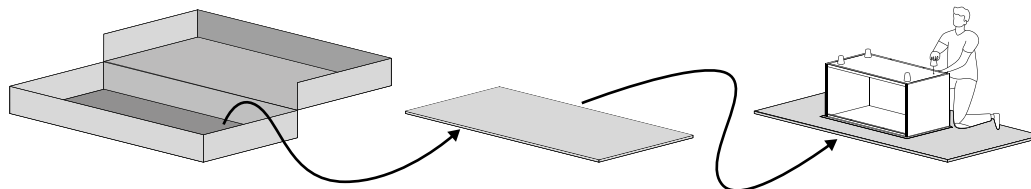

**Temps de montage
estimé**

**Tiempo estimado de
montaje**

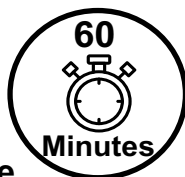

2 Personnes
2 Personas

**Personnes recommandées
pour le montage**

Fais-en un effort d'équipe !
Appelle un ami pour un assemblage
plus rapide et plus facile.

**Personas recomendadas
para el montaje**

¡Hágalo en equipo!
Llame a un amigo para que el
montaje sea más rápido y sencillo.

Outils nécessaires

Munis-toi d'un tournevis, tournevis cruciforme et marteau pour réaliser cet assemblage.

Herramientas requeridas

Tome un destornillador, destornillador Phillips y martillo para conquistar este montaje.

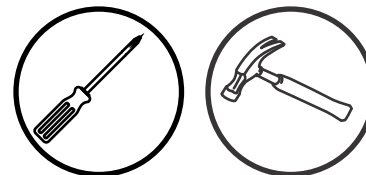

Utilise les outils électriques avec précaution

Ce meuble est réalisé en Bois Massif et Bois Composite, des matériaux souples. Si tu choisis d'utiliser des outils électriques, règle-les sur le mode le plus lent. Fais attention à toi ! Les outils électriques peuvent provoquer des fissures ou endommager les meubles, mais aussi les autres composants s'ils sont mal utilisés.

Utilice las herramientas eléctricas con cuidado.

Este mueble está fabricado con madera maciza y madera compuesta, materiales blandos. Si decide utilizar herramientas eléctricas, ajústelas al ajuste más lento. Tenga cuidado. Las herramientas eléctricas pueden causar grietas o daños en el mueble, pero también en los herrajes si se utilizan mal.

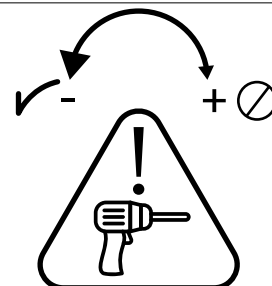



Liste de pièces / Lista de piezas

Nombre de pièces Número de pieza	Description Descripción	Quantité Cantidad
1	Left Panel Left Panel	1
2	Right Panel Right Panel	1
3	Top Panel Top Panel	1
4	Front Rail Front Rail	1
5	Back Rail Back Rail	1
6	Back Panel Back Panel	1
7	Center Rail Center Rail	1
8	Drawer Front Drawer Front	4
9	Right Drawer Side Right Drawer Side	3
10	Left Drawer Side Left Drawer Side	4
11	Drawer Back Drawer Back	4
12	Drawer Bottom Drawer Bottom	4
14	Right Drawer Side With Warning Right Drawer Side With Warning	1



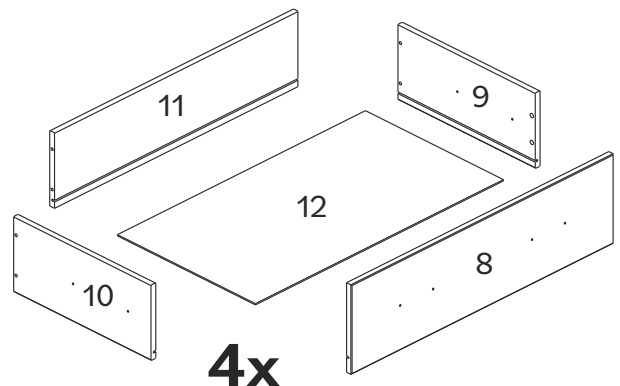
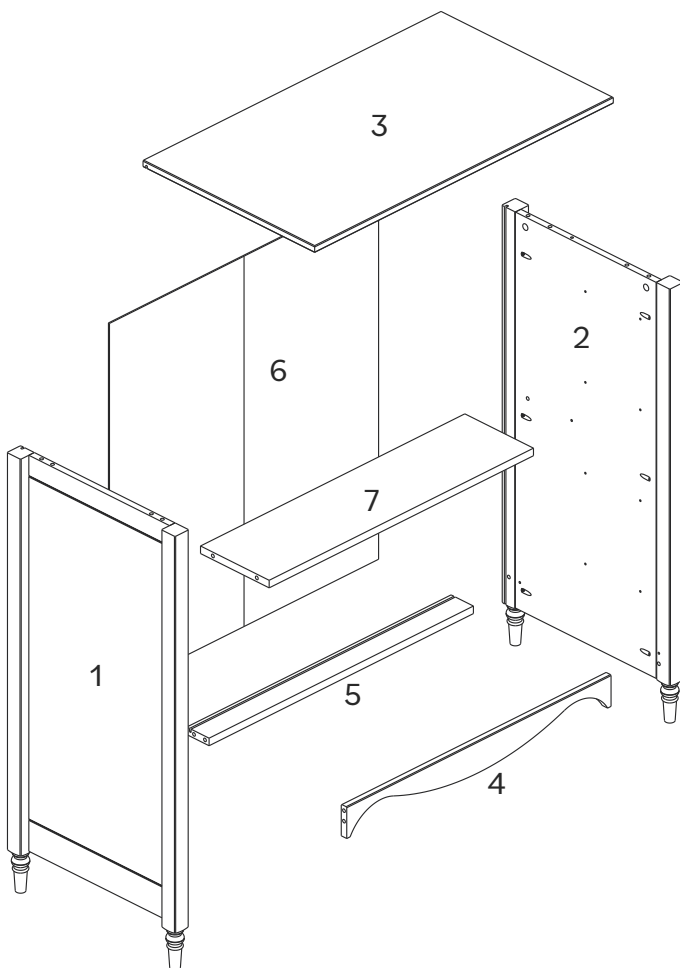







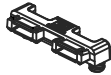





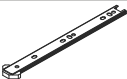

The side drawer with **WARNING LABEL**, should be mounted in highest drawer.

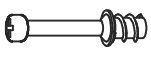
The side drawer with **WARNING LABEL**, should be mounted in highest drawer.

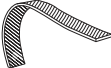

⚠ WARNING	
	<p>Children have died from furniture tipover. To reduce the Risk of furniture tipover:</p> <ul style="list-style-type: none"> -ALWAYS install anti tip device provided. -NEVER put a TV on this product. -NEVER allow children to stand, climb or hang on any drawers, doors, or shelves. -NEVER open more than one drawer at a time. -DO NOT defeat or remove the drawer interlock system; it is an important stability and safety system. -Place heaviest items in the lowest drawers. <p><i>This is a permanent label. Do not remove!</i></p>
	<p>DO NOT remove the interlock system except for maintenance as shown. NEVER use the unit without the interlock installed following the instructions.</p> <p>System Specific Instructions for interlock installation.</p> <p>Insert Interlock Lock on the sliders. After securing the sliders to the cabinet, attach the Interlock Bars to the Locks. Once this is done you can place the drawer one at a time. To remove the drawer push the locks in the sliders.</p>

Liste de composants / Lista de hardware

Partie Parte	Taille Tamaño	Nom Nombre	Quantité Cantidad
A 		Dovetail Dovetail	8
B 		Dovetail Lock Dovetail Lock	16
C 		Plastic Screw Plastic Screw	16
D 	6x12mm	Screw Screw	16
E 		Interlock Lock Interlock Lock	8
F 	6x14mm	Screw Screw	16
G1 	250mm	Outer Slider Outer Slider	8
G2 	250mm	Inner Slider Inner Slider	8
H 		Handle Handle	8
I 	M4x19mm	Screw Screw	16
J 	8x30mm	Wooden dowel Wooden dowel	10
K 	6x31mm	Cam bolt Cam bolt	10
L 	15x11mm	Cam Lock Cam Lock	10
M 		Interlock Bar Interlock Bar	3
N 		Wedge Wedge	12
O 	4x40mm	Screw Screw	1
P 		Wall anchor Wall anchor	1
Q 	4x16mm	Screw Screw	1
R 	6x35mm	Plastic bush Plastic bush	1
S 		Washer Washer	2
T 	3,5X14mm	Screw Screw	12

Les quantités de composants indiquées ci-dessus sont nécessaires pour un assemblage correct.

Des pièces supplémentaires peuvent être incluses.

Las cantidades de tornillería indicadas anteriormente son necesarias para un montaje correcto.

Se pueden incluir piezas de ferretería adicionales.

Introduction pour un assemblage facile du système de tiroirs

Dis adieu au tracas de l'assemblage !

Nous comprenons que l'assemblage des tiroirs peut être la partie la plus longue et la plus fastidieuse de l'assemblage de tes nouveaux meubles. C'est pourquoi nous avons développé le système de tiroirs d'assemblage facile - pour rendre le processus plus facile !

Dovetail Verrouillage Traba

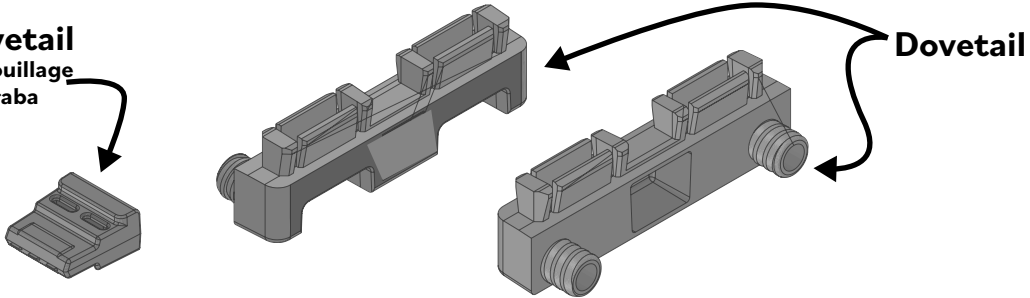

Pourquoi tu vas adorer notre système de tiroirs d'assemblage facile :

Rapide et facile : notre nouveau système de tiroir réduit considérablement le temps d'assemblage. Fais-le vite !

Effort minimal requis : Conçu pour être extrêmement simple, tu n'auras besoin que de peu ou pas d'outils pour effectuer le travail.

Construit pour durer : Solide et résistant, notre système garantit que tes tiroirs restent solides et fiables.

Préparons le scénario pour l'assemblage :

Step 1: Prépare-toi -

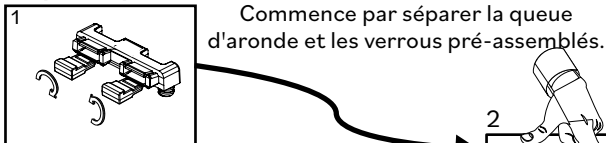

Commence par séparer la queue d'aronde et les verrous pré-assemblés.

Step 2: Jonction -
Combine la queue d'aronde avec les côtés du tiroir comme indiqué sur l'illustration.

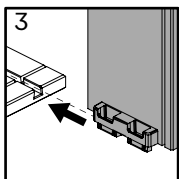
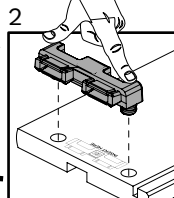

Step 3: Glisse dans la rainure -
Fais glisser la queue d'aronde dans les rainures de la face avant des tiroirs.

Step 4: Verrouillage -
Après avoir installé le fond du tiroir, verrouille la queue d'aronde à l'aide des loquets à queue d'aronde

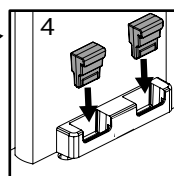

Attention : Lors des prochaines étapes, tu trouveras plus de détails pour t'aider durant l'assemblage.

Introducción al Sistema de Fácil Montaje de Cajones

¡Despídete de las complicaciones del montaje!

Entendemos que ensamblar cajones puede ser la parte más lenta y tediosa de ensamblar tus muebles nuevos. Es por eso que desarrollamos el Sistema de Cajones de Montaje Fácil, ¡para facilitar el proceso!

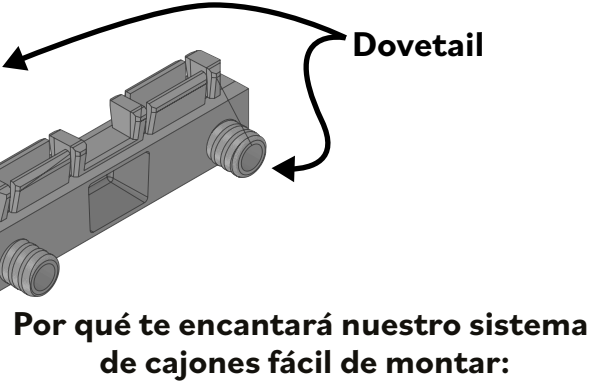

Por qué te encantará nuestro sistema de cajones fácil de montar:

Rápido y fácil : nuestros nuevos herrajes para cajones reducen significativamente el tiempo de montaje. ¡Hazlo rápido!

Mínimo esfuerzo requerido : Diseñado para ser muy simple, necesitarás pocas o ninguna herramienta para hacer el trabajo.

Fabricado para durar : Fuerte y resistente, nuestro sistema garantiza que tus cajones permanezcan sólidos y confiables.

Preparamos el espacio para el montaje:

Step 1: ¡Prepárate! -

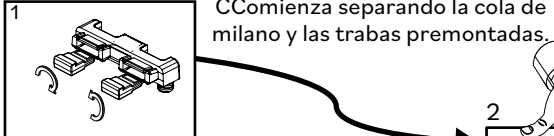

Comienza separando la cola de milano y las trabas premontadas.

Step 2: Unión -
Combina la cola de milano con los lados del cajón, como se muestra en la ilustración.

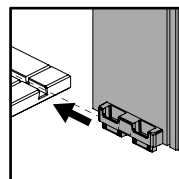
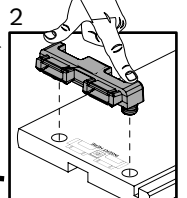

Step 3: Desliza en la ranura -
Desliza la cola de milano en las ranuras de los frentes de los cajones.

Step 4: Traba -
Después de colocar la parte inferior del cajón, bloquea la cola de milano usando las trabas de cola de milano.

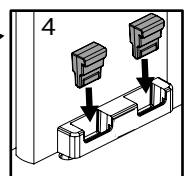

Atención: En los próximos pasos, hay más detalles para ayudarte con el montaje.

Step 1

Prepare the Dovetails (A) by removing the Dovetail Locks (B) from the Dovetails (A).

1st

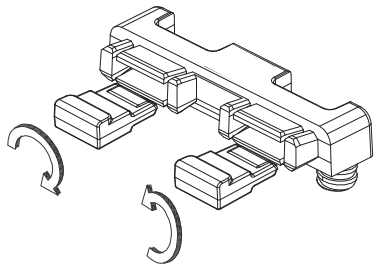

2nd

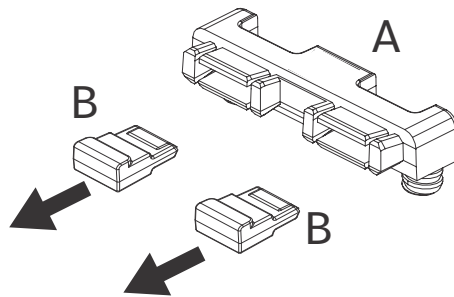

Step 2

Snap the Dovetails (A) into place on Right Drawer Sides (9 and 14) and Left Drawer Sides (10). Press the Dovetails until they are completely attached. Use a hammer if necessary.

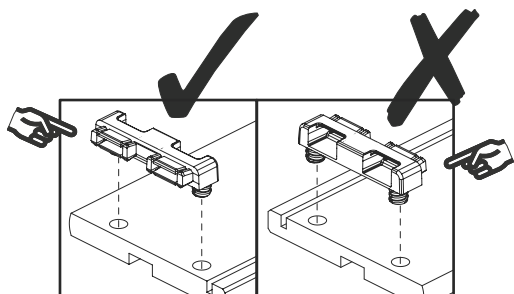

Press the piece until it is completely attached

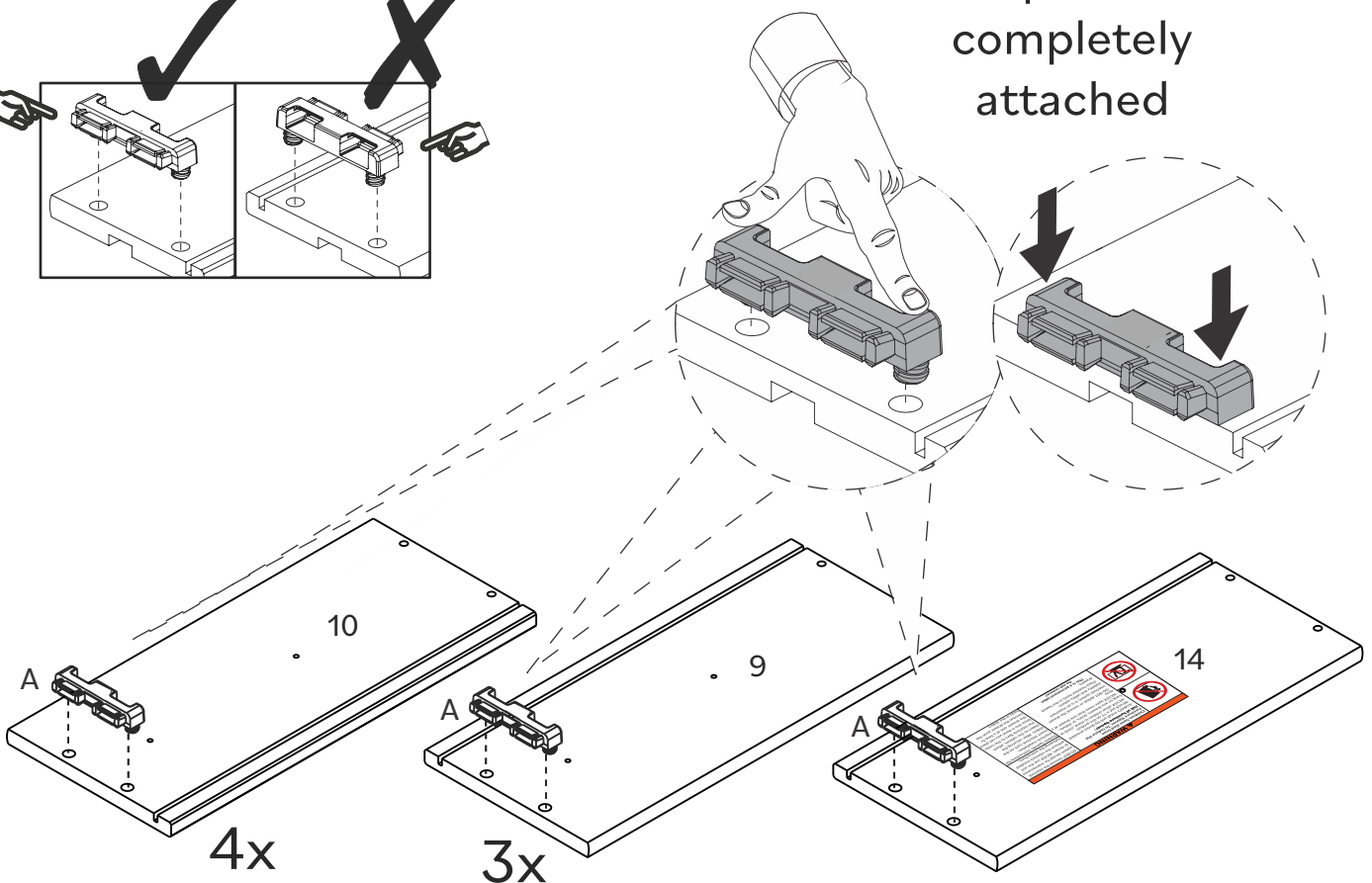

Étape / Paso 3

(FR)

Faites glisser la Dovetail(A) du panneau de tiroir droit (9/14) et du panneau de tiroir gauche (10) dans les rainures de la façade du tiroir (8).

(ES)

Deslice la Dovetail(A) del panel del cajón derecho (9/14) y del panel del cajón izquierdo (10) en las ranuras del frente del cajón (8).

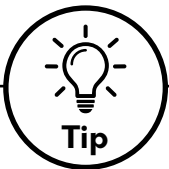
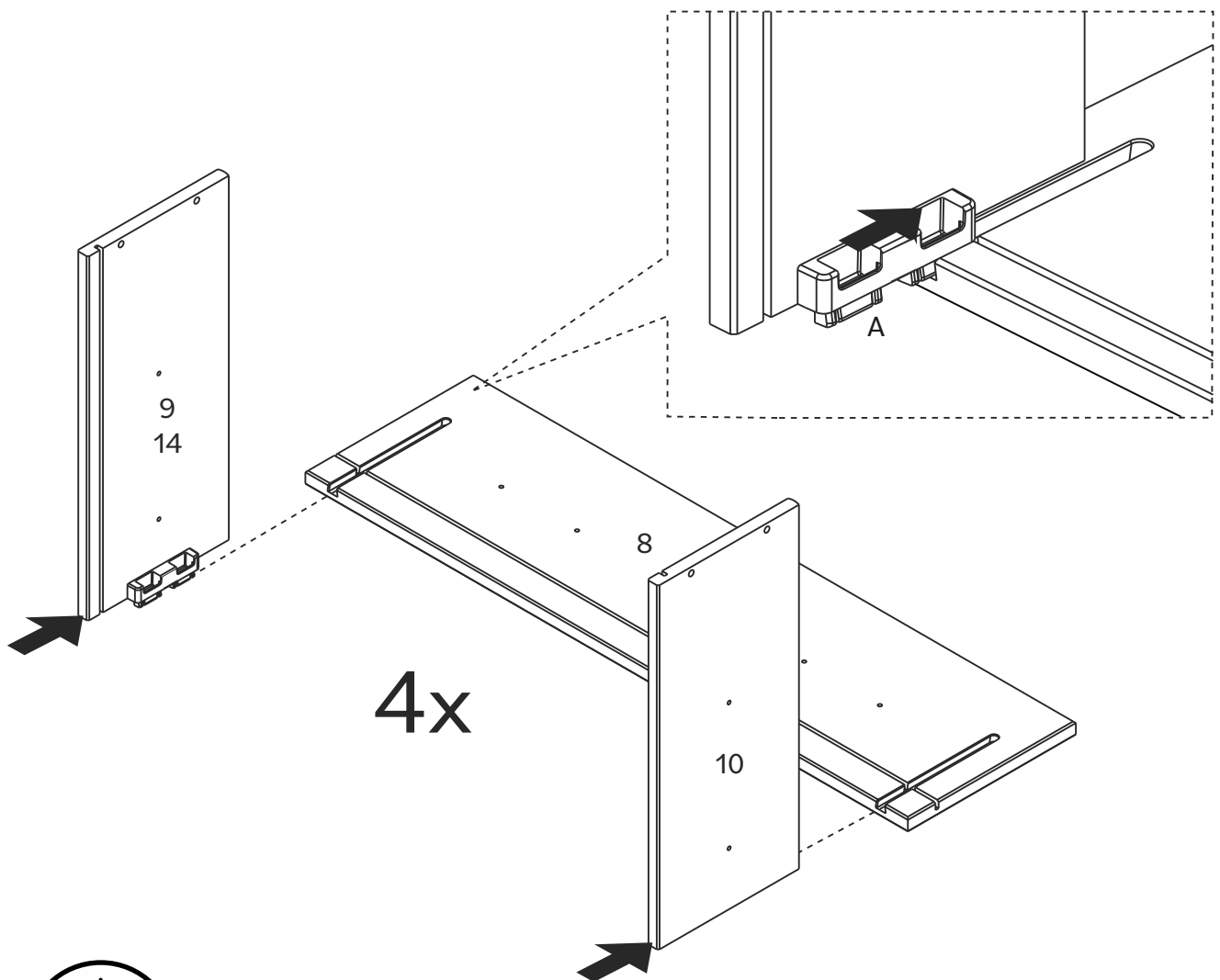

Tip

Pour que ton produit conserve son meilleur aspect et sans rayures, essaie de le monter sur une surface souple telle qu'un tapis ou une couverture. Cela permet d'éviter les rayures accidentelles et de garder tes meubles en bon état !

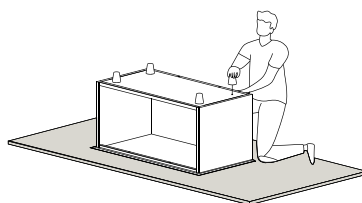

Para mantener su producto con el mejor aspecto y sin arañazos, pruebe a montarlo sobre una superficie blanda, como una alfombra o una manta. Así evitará arañazos accidentales y mantendrá sus muebles en perfecto estado.

Étape / Paso 4



(FR)

Faites glisser le fond du tiroir (12) entre les rainures du côté droit du tiroir (9 et 14) et du côté gauche du tiroir (10) en l'insérant dans la façade du tiroir (8).

(ES)

Deslice la parte inferior del cajón (12) entre las ranuras del lado derecho del cajón (9 y 14) y el lado izquierdo del cajón (10) encajando en el frente del cajón (8).

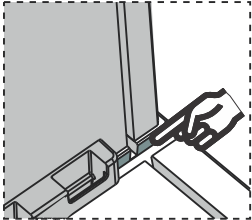

Alinez les rainures sur les côtés et le devant du tiroir pour recevoir le fond du tiroir

Alinee las ranuras en los lados y el frente del cajón para recibir la parte inferior del cajón.

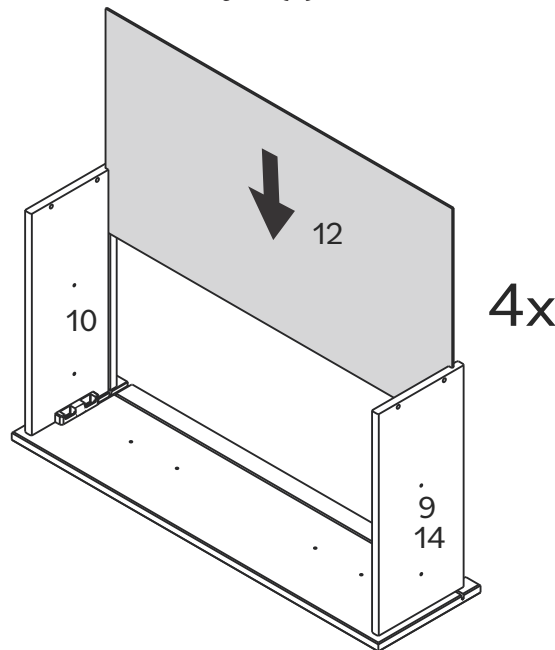

Étape / Paso 5



(FR)

Pour fixer les côtés du tiroir, insérez les Dovetail Lock(B) dans les Dovetail(A). Utilisez un marteau si nécessaire.

(ES)

Para asegurar los laterales del cajón, inserte los cierres de Dovetail(B) en las Dovetail(A). Use un martillo si es necesario.

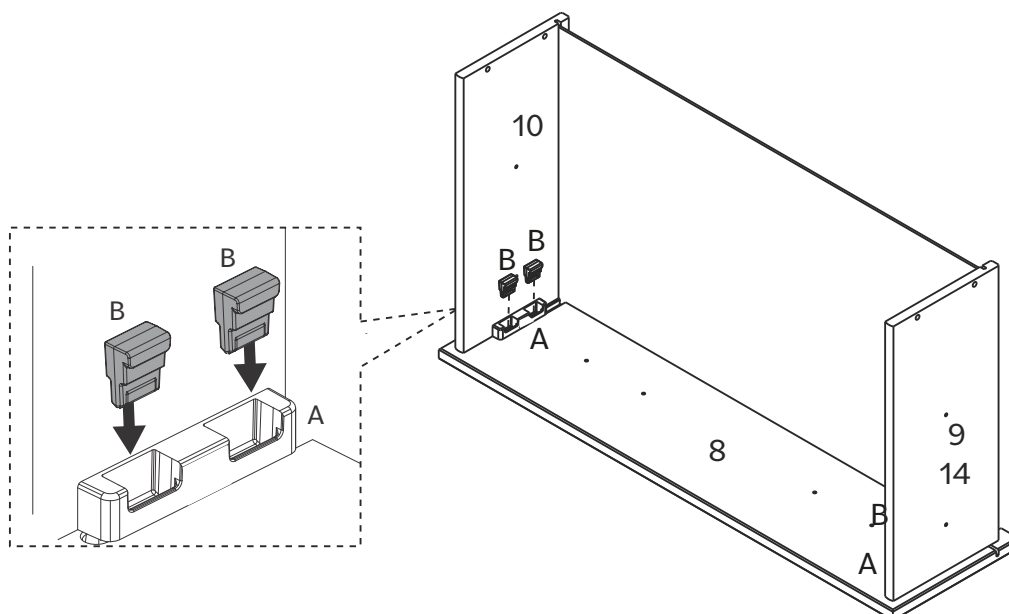

Une fois cette étape terminée, votre produit devrait ressembler à ceci:

Una vez completado este paso, su producto debería verse así:

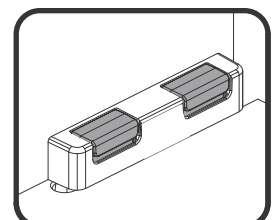

Étape / Paso 6

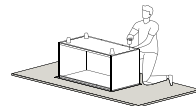

(FR)

Fixez le fond du tiroir (12) au dos du tiroir (11) et fixez-le à l'aide de la vis en plastique (C). Vous pouvez l'insérer avec vos mains ou à l'aide d'un marteau.

(ES)

Coloque la parte inferior del cajón (12) en la parte posterior del cajón (11) y asegúrelo con el tornillo de plástico (C), puede insertarlo con las manos o con un martillo.

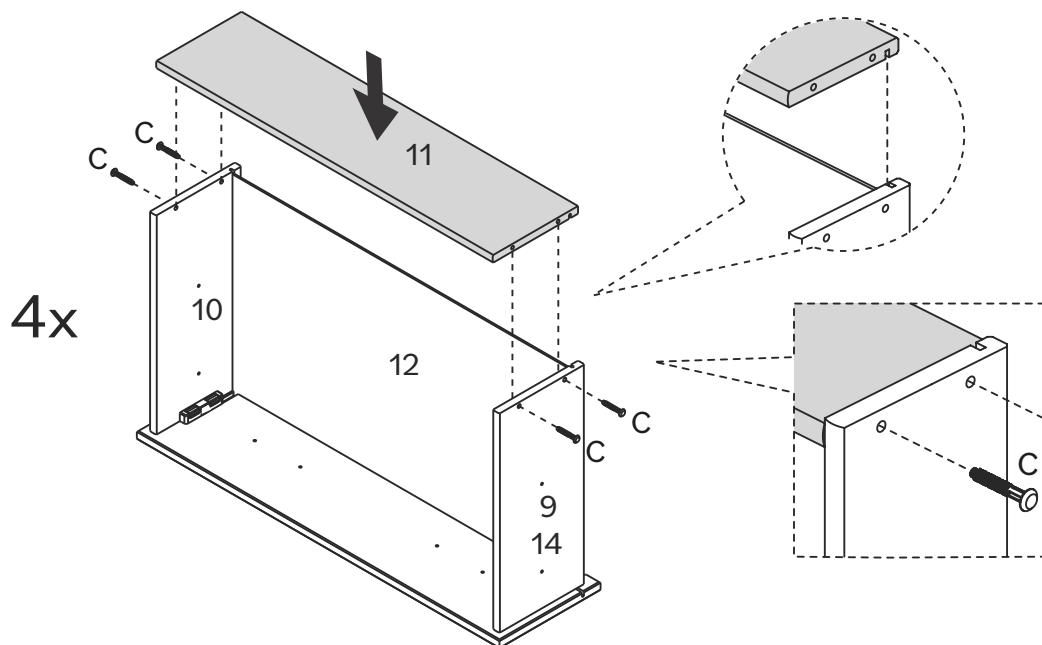

Étape / Paso 7



(FR)

Fixez les glissières intérieures (G2) sur les côtés droits du tiroir (9 et 14) et les côtés gauches du tiroir (10) à l'aide de la vis (D) et d'un tournevis cruciforme.

(ES)

Coloque los deslizadores internos (G2) en los lados del cajón derecho (9 y 14) y en los lados del cajón izquierdo (10) usando el tornillo (D) y un destornillador Phillips.

Séparez les parties G1 et G2 en appuyant sur le verrou.

Separe las piezas G1 y G2 presionando el bloqueo.

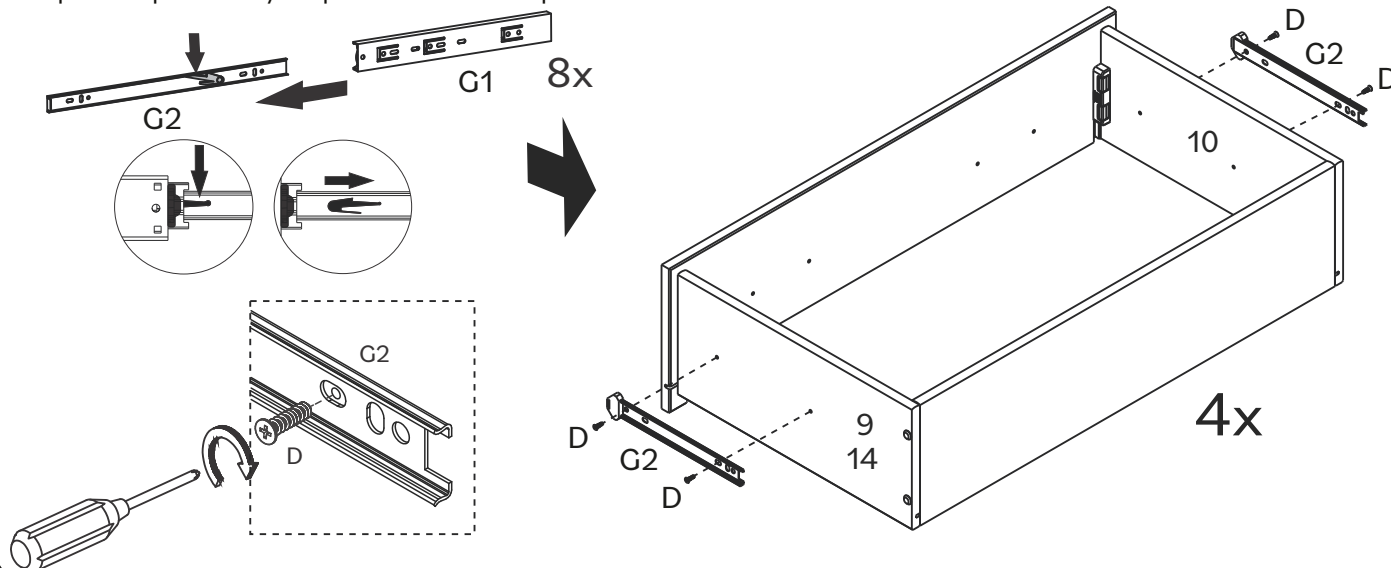

Étape / Paso 8

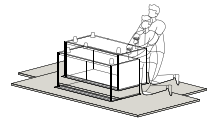

(FR)

Utilisez des vis (I) et un tournevis cruciforme pour fixer les poignées (H) aux façades des tiroirs (8).

(ES)

Utilice tornillos (I) y un destornillador Phillips para asegurar las manijas (H) a los frentes de los cajones (8).

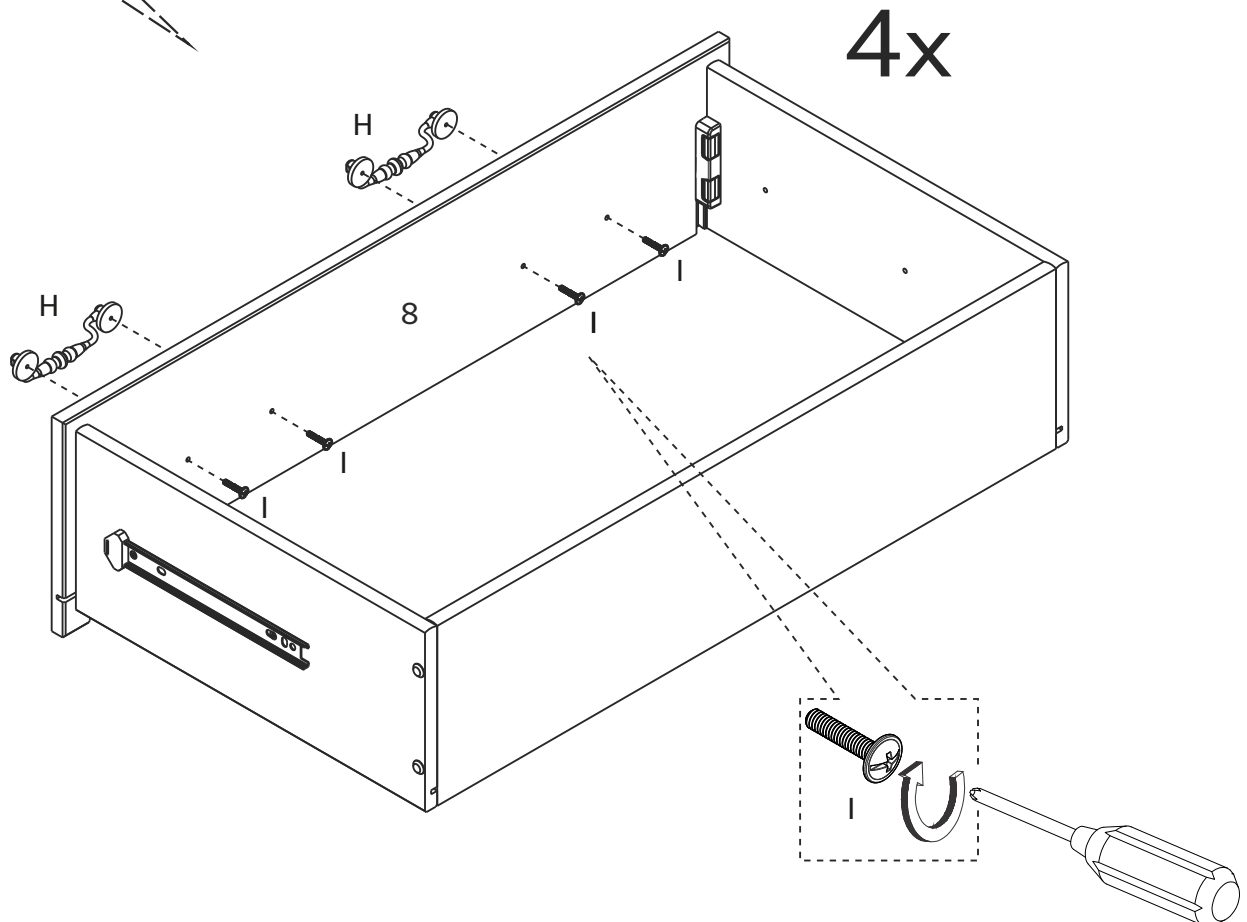
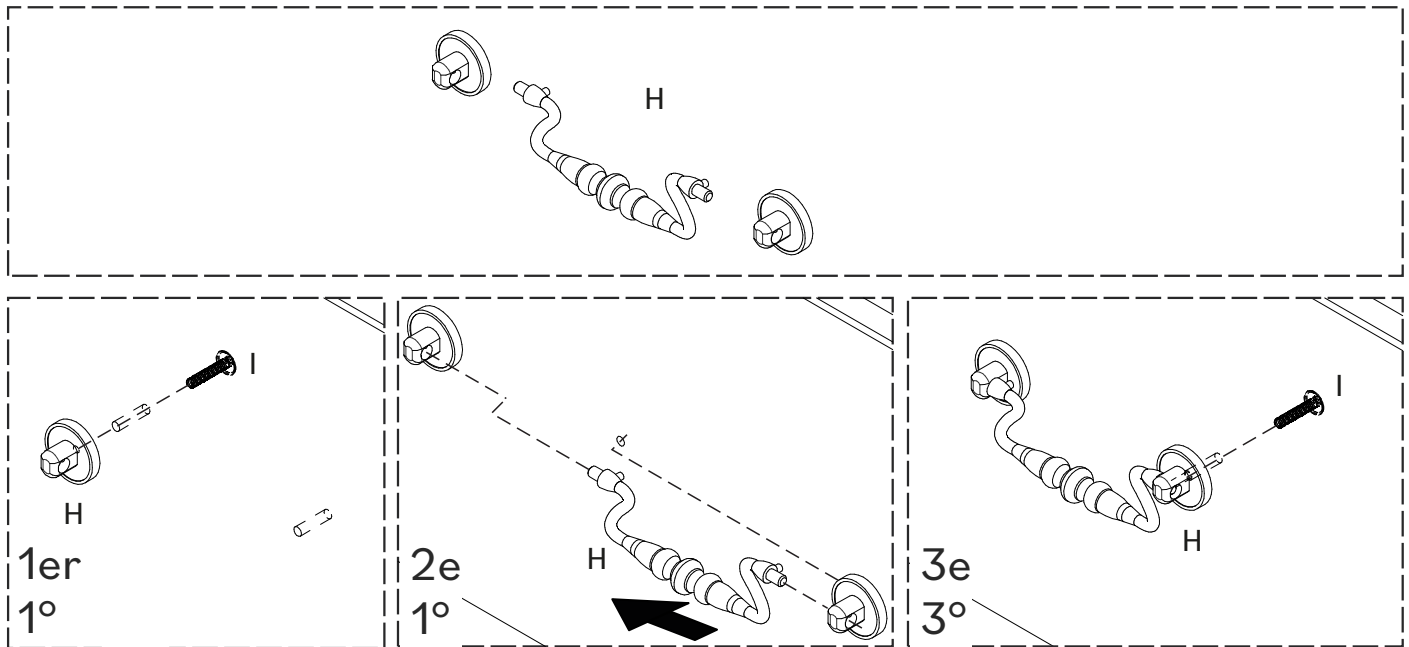

Étape / Paso 9



(FR)

Insérez les chevilles en bois (J) dans le panneau gauche (1), le panneau droit (2), le rail avant (4), le rail arrière (5) et le rail central (7).

(ES)

Inserte las espigas de madera (J) en el panel izquierdo (1), el panel derecho (2), el riel delantero (4), el riel trasero (5) y el riel central (7).

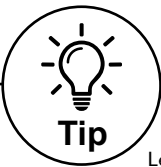
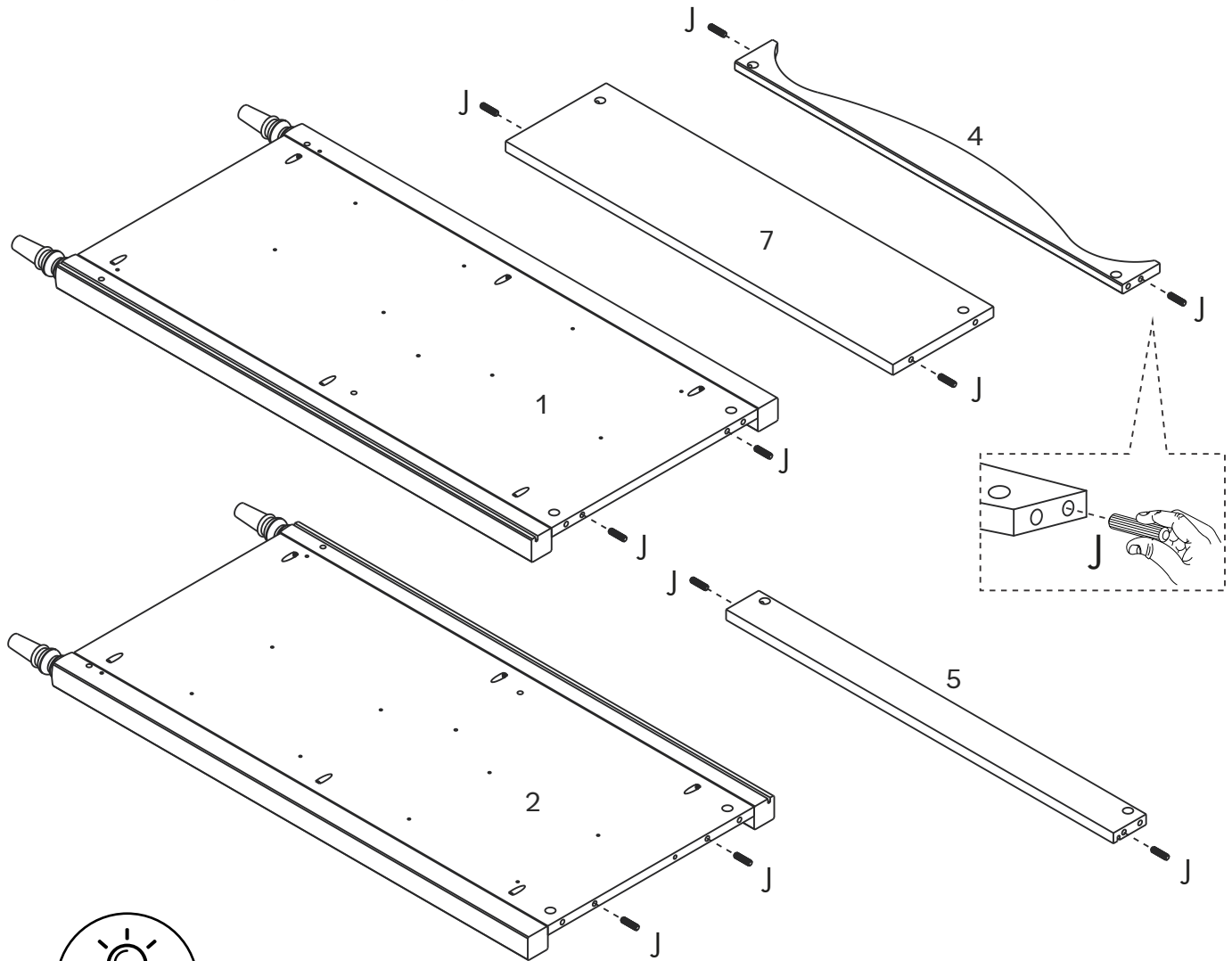

Tip

Cheville en bois

Les chevilles sont essentielles lors de l'assemblage de meubles pour créer des connexions solides et précises. Elles garantissent l'intégrité structurelle, empêchent les déplacements et simplifient l'alignement, ce qui permet d'obtenir des meubles plus résistants et plus durables. suis ces étapes :

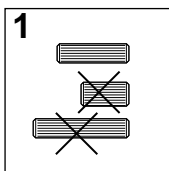

- 1: Sélectionne la taille de cheville appropriée en fonction de l'étape.
- 1: Seleccione el tamaño de espiga adecuado según el paso.

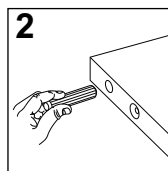

- 2: Insère dans le trou indiqué et appuie fermement pour assurer un positionnement correct.
- 2: Insértela en el orificio indicado y presione firmemente para asegurar su correcta colocación.

Espiga de madera

Las espigas son esenciales en el montaje de muebles para crear uniones fuertes y precisas. Garantizan la integridad estructural, evitan el desplazamiento y simplifican la alineación, lo que se traduce en muebles más resistentes y duraderos.

Sigue estos pasos:

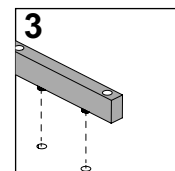

- 3: Alinee la cheville avec la pièce correspondante et enfonce-la jusqu'à ce qu'elle soit ferme.
- 3: Alinee el pasador con la pieza correspondiente y presiónelo hasta que encaje.

Étape / Paso 10



(FR)

Fixez les goujon(K) au panneau gauche (1), au panneau droit (2) et au panneau supérieur (3).

(ES)

Coloque los conector (K) en el panel izquierdo (1), el panel derecho (2) y el panel superior (3).

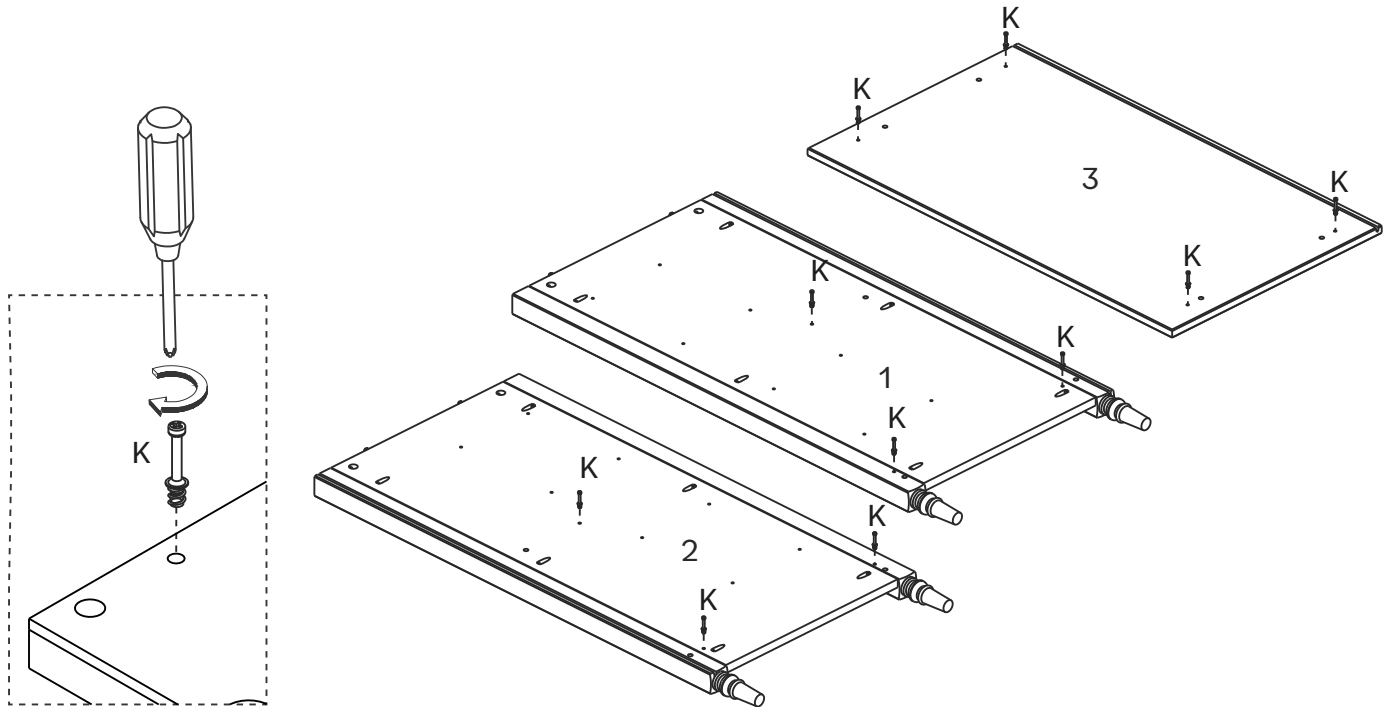

Étape / Paso 11

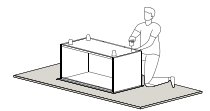

(FR)

Prenez le curseur extérieur (G1) et insérez le verrou de verrouillage (E) conformément au schéma ci-dessous

(ES)

Tome el control deslizante externo (G1) e inserte el bloqueo de interbloqueo (E) de acuerdo con el diagrama a continuación.

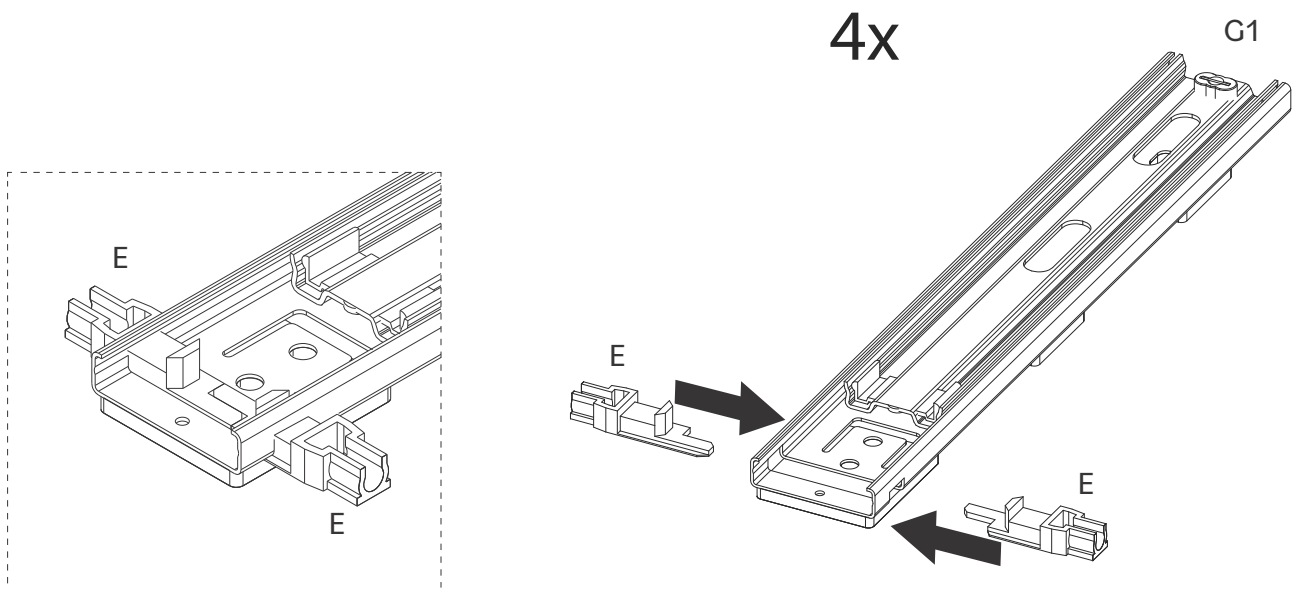

Étape / Paso 12



(FR)

Fixez le curseur extérieur (G1) au panneau droit (2) et au panneau gauche (1) à l'aide de la vis (F) et d'un tournevis cruciforme.

(ES)

Asegure el control deslizante exterior (G1) al panel derecho (2) y al panel izquierdo (1) usando el tornillo (F) y un destornillador Phillips.

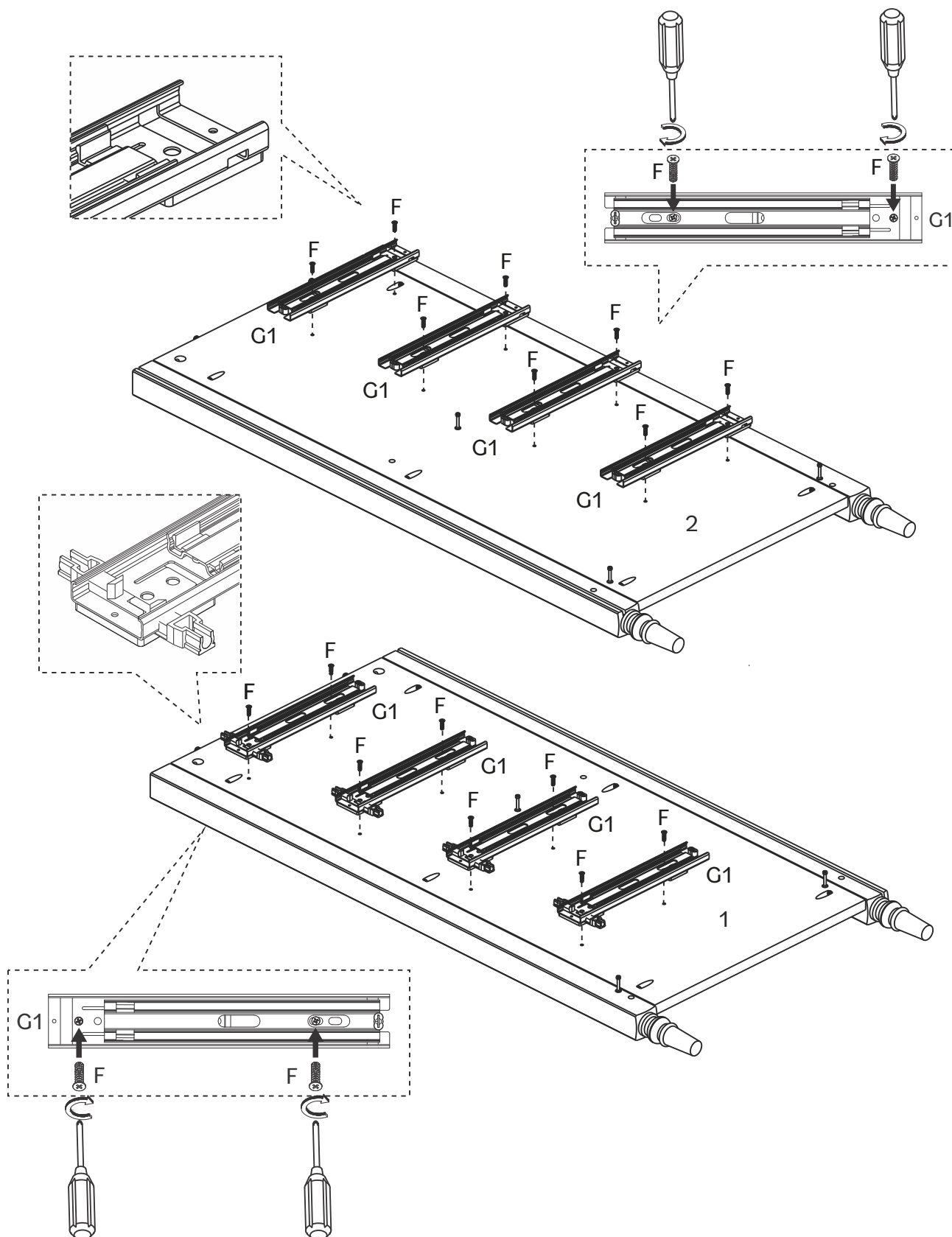

Étape / Paso 13

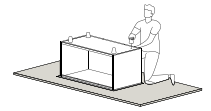

(FR)

Fixez le rail avant (4), le rail arrière (5) et le rail central (7) au panneau gauche (1) à l'aide du boîtier (L) et d'un tournevis cruciforme.

(ES)

Conecte el riel delantero (4), el riel trasero (5) y el riel central (7) al panel izquierdo (1) usando el traba (L) y un destornillador Phillips.

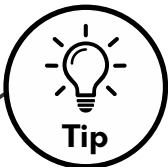
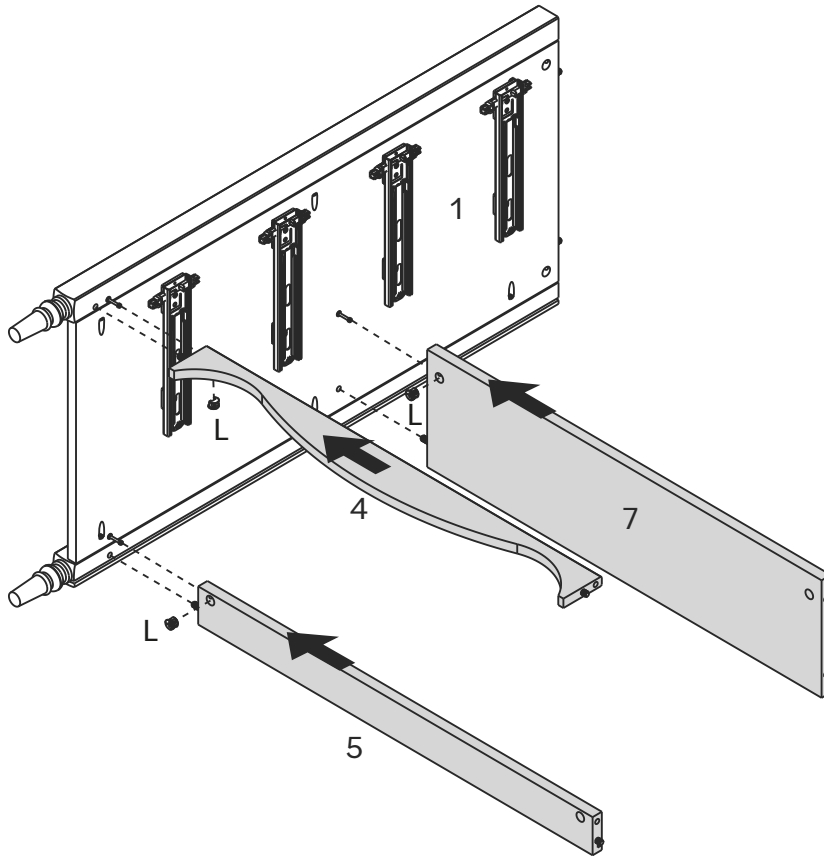

Tip

Goujon de Assemblage

Goujon de Assemblage permet de joindre deux pièces en toute sécurité. Suis ces étapes simples.

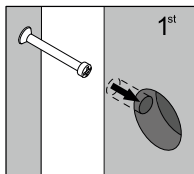

1: Insère le Goujon dans les orifices du côté plat. Ne serre pas trop !

1: Coloca el Conector en los orificios del lado plano. ¡No aprietes demasiado!

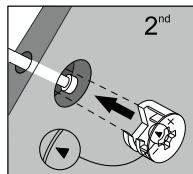

2: Joins les pièces en bois. Les Goujons entrent dans les orifices qui ont des trous sur les côtés, tu dois pouvoir voir les Goujons à travers ceux-ci.

Après avoir installé les pièces, insère le Boîtiers dans les orifices latéraux
2: Una las piezas de madera. Los Conectores entran en las piezas que tienen orificios en los lados, por lo que deberías poder ver los Conectores a través de ellos. Después de encajar las piezas, inserta la traba en los orificios laterales.

Conector

Los Conector ayudan a unir de forma segura dos piezas. Sigue estas fáciles etapas.

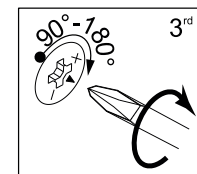

3: Sur la partie arrière du boîtier, il aura la forme d'un « C ». Insère le boîtier de manière à ce que l'ouverture « C » s'emboîte à la goujon. Serre-la avec le tournevis.
3: La parte posterior de la traba tendrá la forma de "C". Inserta el tambor de modo que la abertura de la "C" encaje en el Conector. Apriétalo con un destornillador.

Étape / Paso 14

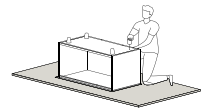

(FR)

Joignez le panneau droit (2) au rail avant (4), au rail arrière (5) et au rail central (7) à l'aide du boîtier (L) et d'un tournevis cruciforme.

(ES)

Una el panel derecho (2) al riel frontal (4), al riel posterior (5) y al riel central (7) usando el traba (L) y un destornillador Phillips.

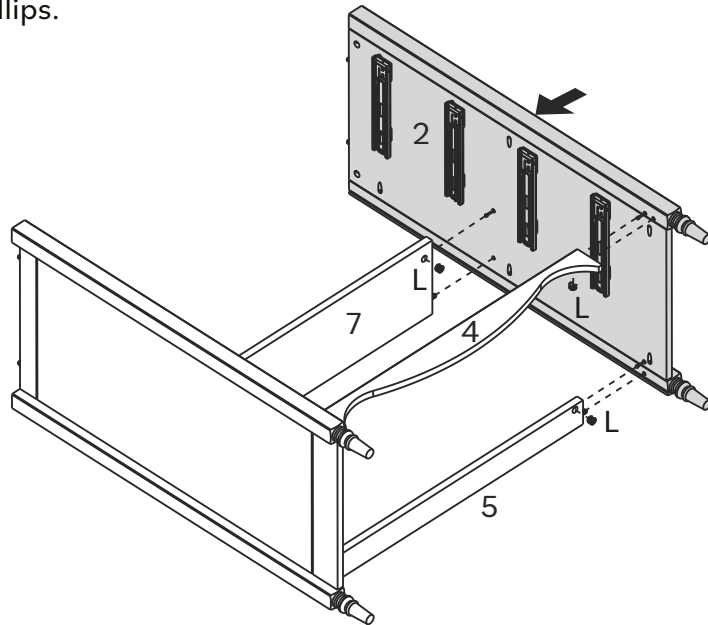
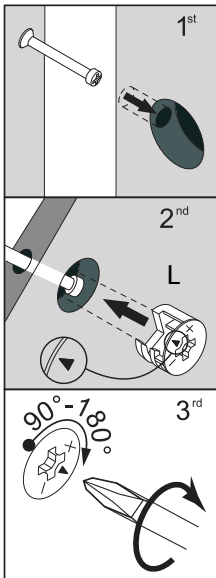

Étape / Paso 15



(FR)

Faites glisser le panneau arrière (6) sur les rainures du panneau gauche (1) et du panneau droit (2), en l'insérant dans le rail arrière (5).

(ES)

Deslice el panel posterior (6) sobre las ranuras del panel izquierdo (1) y del panel derecho (2), ajustándolo en el riel posterior (5).

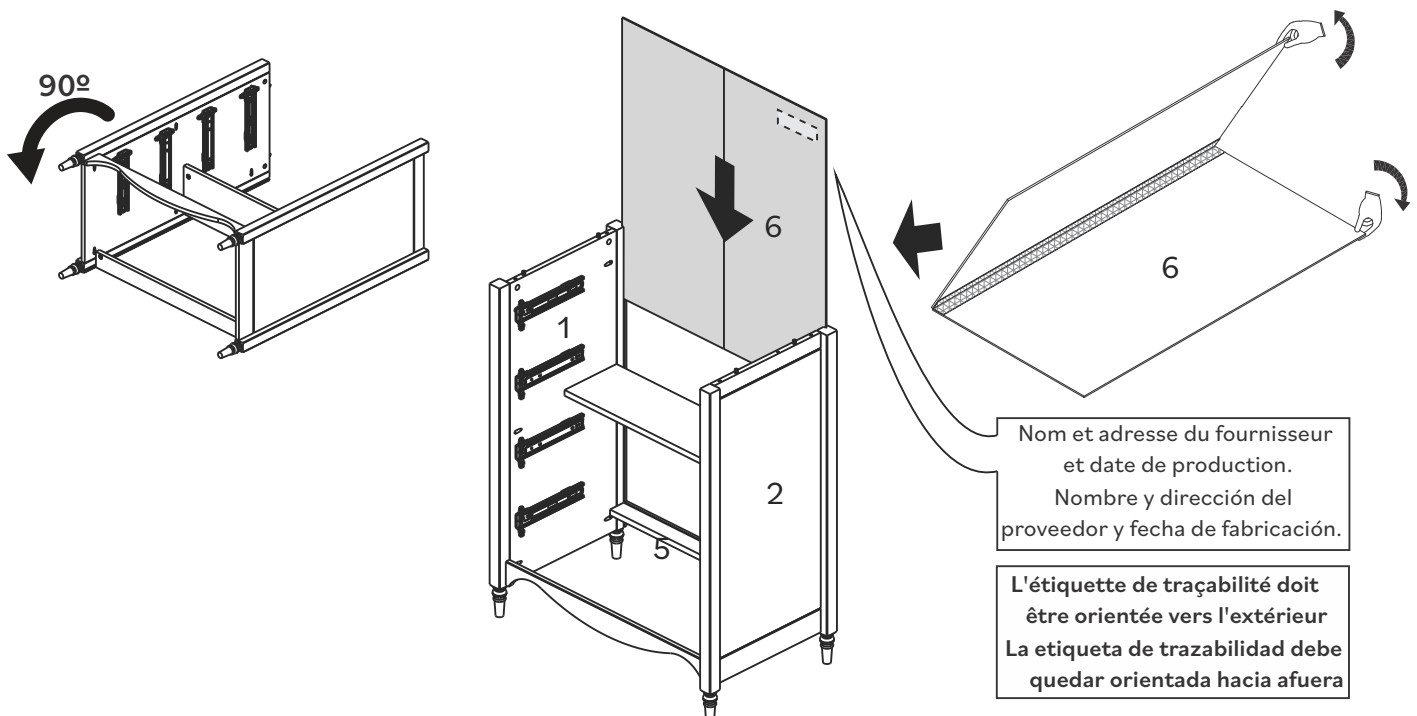

Étape / Paso 16



(FR) Fixez le panneau supérieur (3) au panneau gauche (1) et au panneau droit (2) à l'aide des boîtiers (L) et d'un tournevis cruciforme.

(ES) Asegure el panel superior (3) al panel izquierdo (1) y al panel derecho (2) usando traba (L) y un destornillador Phillips.

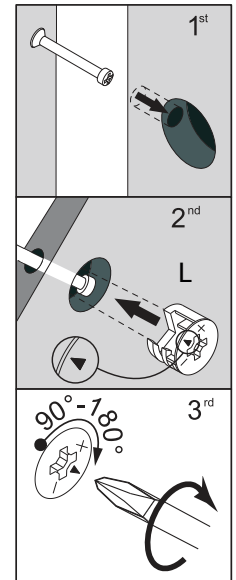
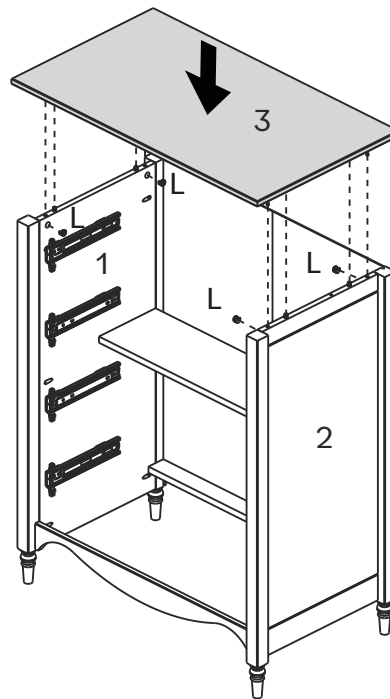

Étape / Paso 17



(FR) Fixez le Panneau Arrière (6) en insérant la Cale (N) et la vis (U) entre le panneau et les rainures. Utilisez un tournevis Phillips.

(ES) Asegure el Panel Trasero (6) colocando la Cuña (N) y el tornillo (U) entre el panel y las ranuras. Use un destornillador Phillips.

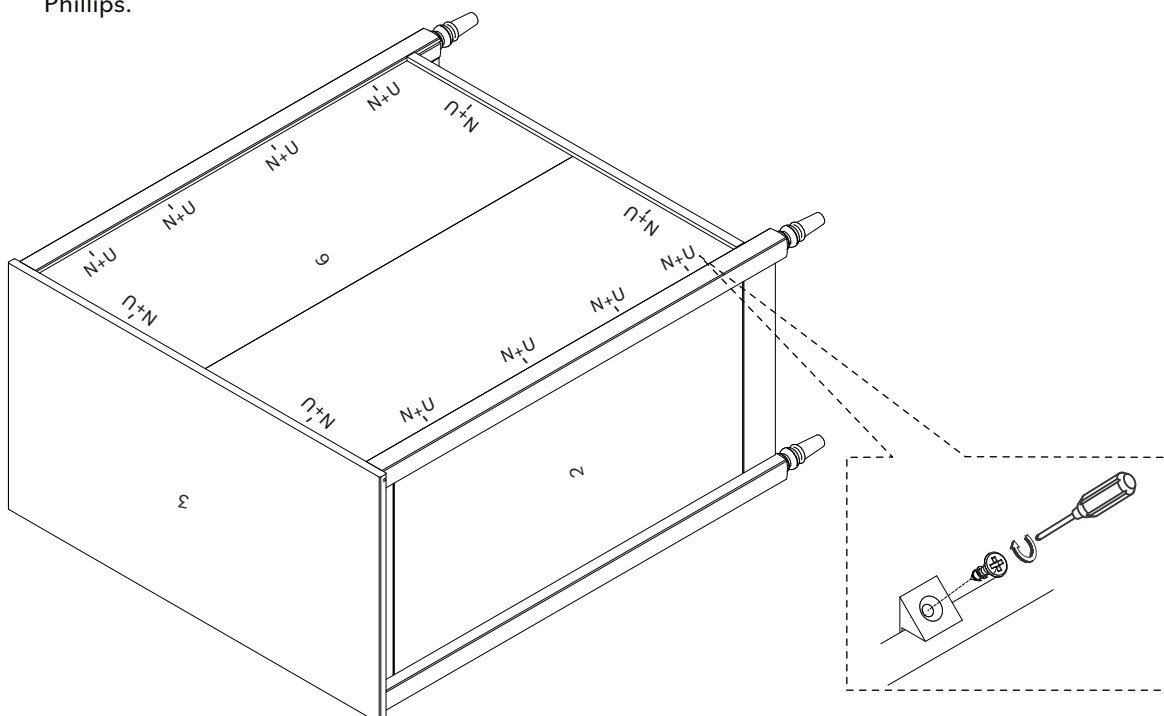

Étape / Paso 18

(FR)
Fixez la barre de Interlock (E) dans les Lock (M).
(ES)
Coloque la barra de Intelock (E) en las Locks (M).

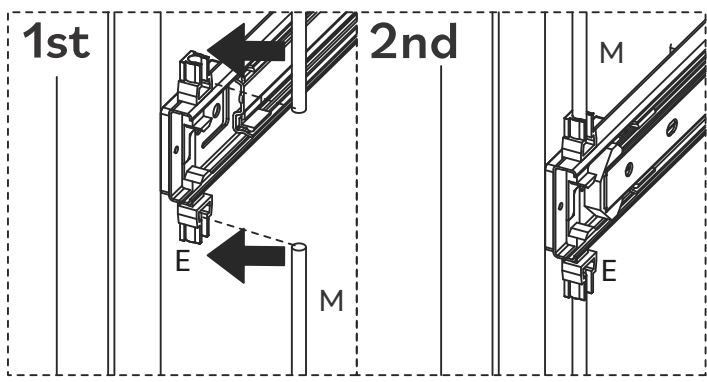
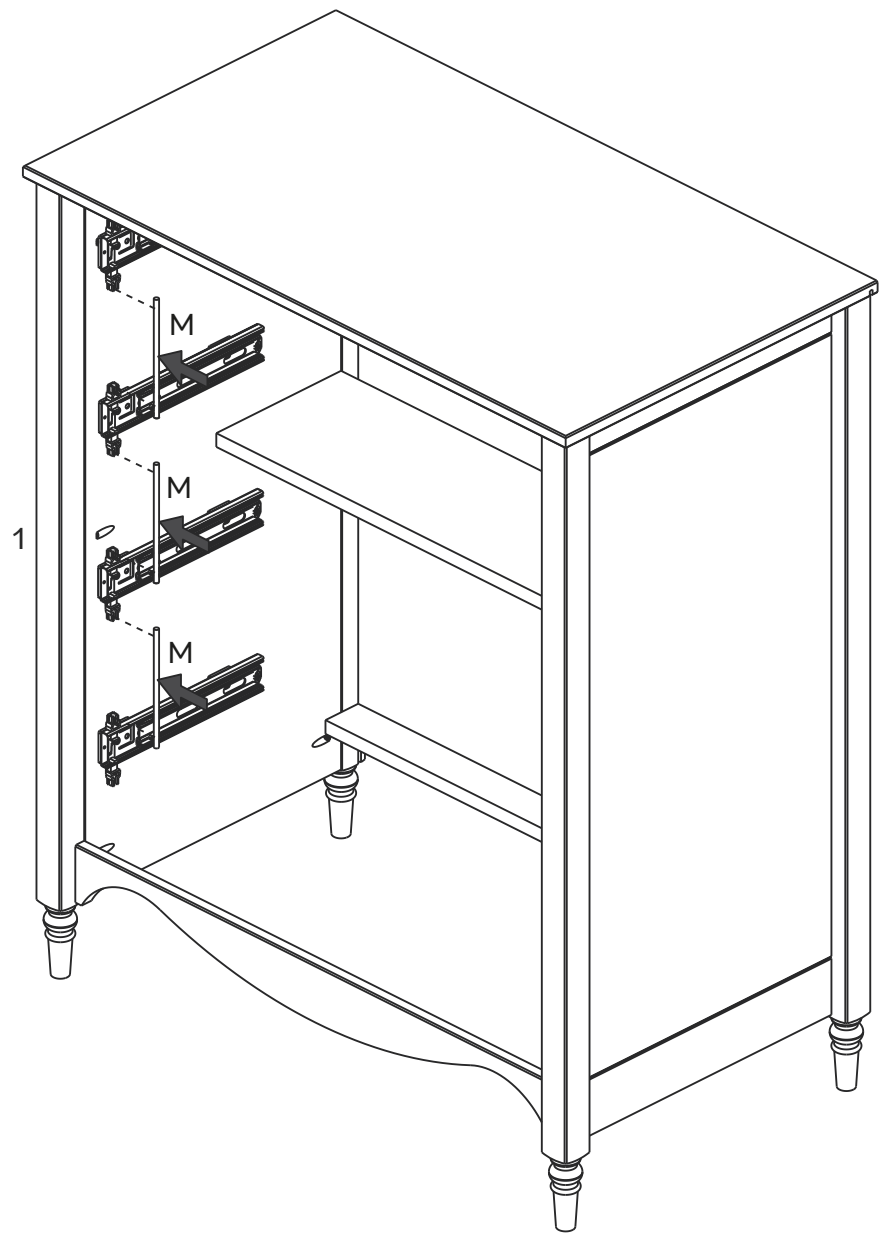

Étape / Paso 19

(FR) Placez les tiroirs un par un à l'aide de la glissière. Veillez à bien aligner les glissières extérieure et intérieure. Le tiroir portant l'étiquette d'avertissement doit être placé en position haute.

(ES) Coloque los cajones uno a uno usando la corredera, asegurándose de alinear correctamente las correderas exterior e interior. El cajón con etiqueta de advertencia debe colocarse en la posición más alta.

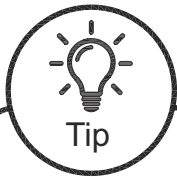
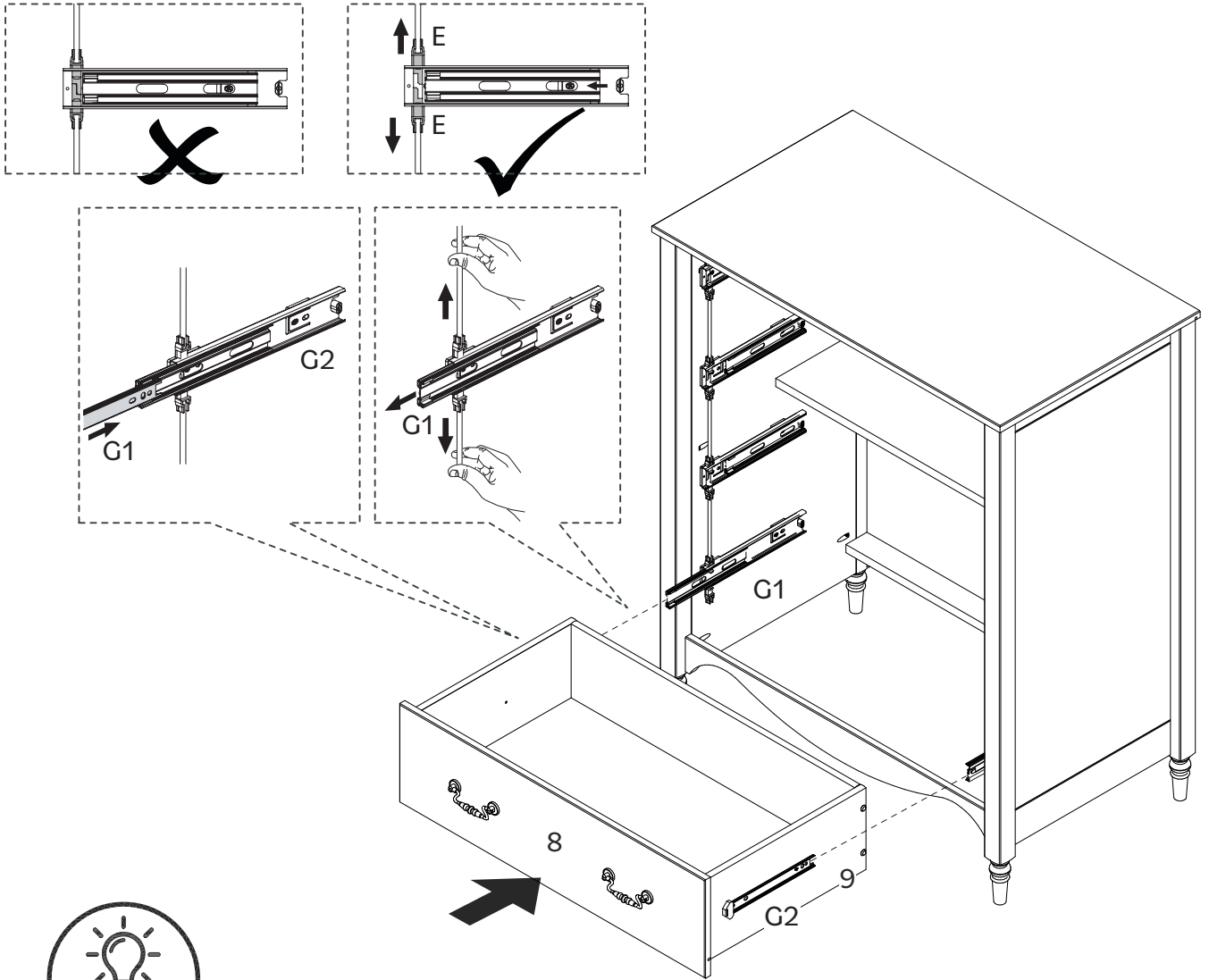

Tip

Reinserting your Cabinet Glides together

Line up the Drawer Member so it is inside the guides of the Cabinet Member.

Once the connection is made, push the drawer into place entirely. It may not be a smooth glide on your first try, but will improve after it's fully inserted.

Reinserting your Cabinet Glides together

Line up the Drawer Member so it is inside the guides of the Cabinet Member.

Once the connection is made, push the drawer into place entirely. It may not be a smooth glide on your first try, but will improve after it's fully inserted.

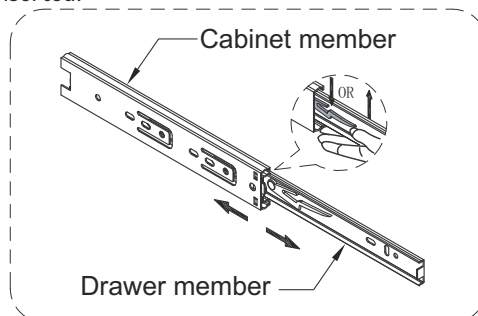

Étape / Paso 20

(FR)

Placez les tiroirs un par un à l'aide de la glissière. Veillez à bien aligner les glissières extérieure et intérieure. Le tiroir portant l'étiquette d'avertissement doit être placé en position haute.

(ES)

Coloque los cajones uno a uno usando la corredera, asegurándose de alinear correctamente las correderas exterior e interior. El cajón con etiqueta de advertencia debe colocarse en la posición más alta.

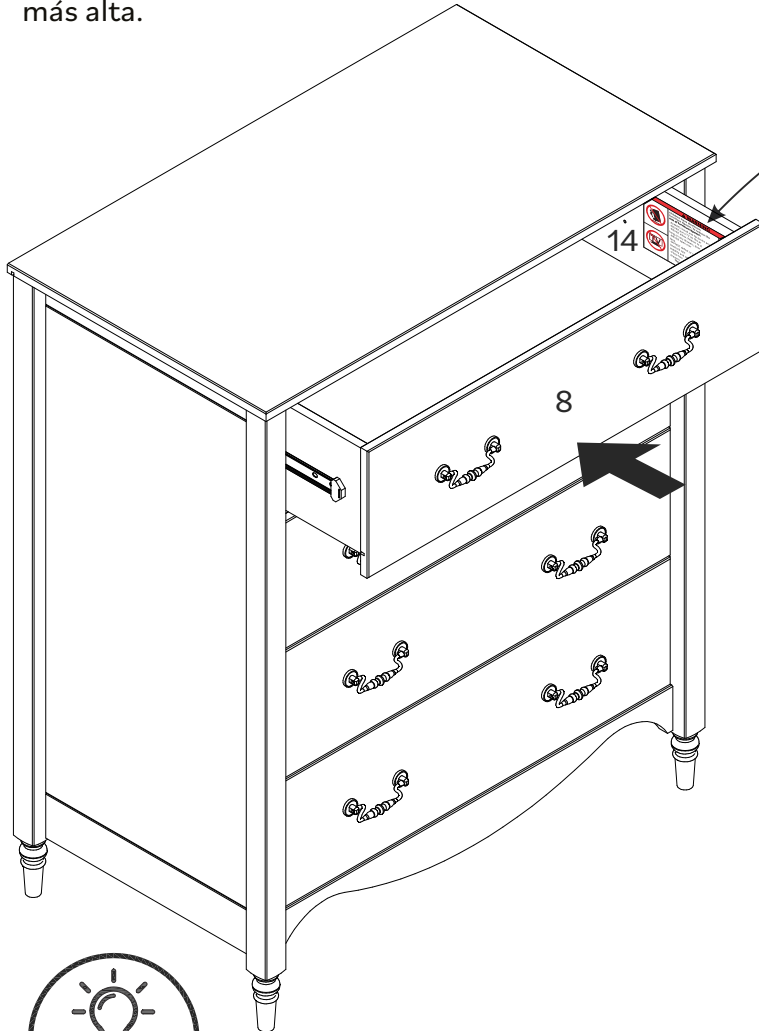

▲ WARNING	
	<p>Children have died from furniture tipover. To reduce the risk of furniture tipover:</p> <ul style="list-style-type: none"> -ALWAYS install anti tip device provided. -NEVER put a TV on this product. -NEVER allow children to stand, climb or hang on any drawers, doors, or shelves. -NEVER open more than one drawer at a time. -DO NOT defeat or remove the drawer interlock system; it is an important stability and safety system. -Place heaviest items in the lowest drawers. <p>This is a permanent label. Do not remove!</p>
	<p>DO NOT remove the interlock system except for maintenance as shown. NEVER use the unit without the interlock installed following the instructions.</p> <p>System Specific Instructions for interlock installation.</p> <p>Insert Interlock Lock on the sliders. After securing the sliders to the cabinet, attach the Interlock Bars to the Locks. Once this is done you can place the drawer one at a time. To remove the drawer push the locks in the sliders.</p>

Le tiroir portant l'étiquette d'avertissement doit être positionné en haut.

El cajón con la etiqueta de advertencia debe colocarse en la posición más alta.

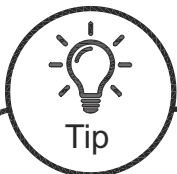
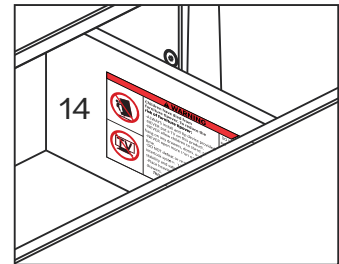

Retrait du tiroir

Il y a un levier blanc dans chaque glissière.
Pour retirer les tiroirs,
tirez le tiroir jusqu'à ce que vous voyiez le levier.
Poussez un levier vers le haut et l'autre vers le bas,
tout en poussant, tirez le tiroir vers l'extérieur.

Extracción del cajón

Hay una palanca blanca en cada riel. Para quitar los cajones,
tire del cajón hasta que vea la palanca.
Empuje una palanca hacia arriba y la otra hacia abajo,
y mientras empuja, saque el cajón.

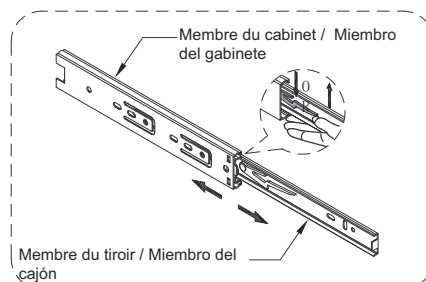

Étape / Paso 21

(FR)

Pour terminer, fixez le kit anti-basculement. Fixez l'ancrage mural (S) au panneau supérieur (3) à l'aide d'une rondelle (S), d'une vis (Q) et d'un tournevis cruciforme en suivant les instructions du schéma ci-dessous.

(ES)

Para finalizar, instale el kit antivuelco. Fije el anclaje de pared (S) al panel superior (3) con la arandela (S), el tornillo (Q) y un destornillador Phillips, siguiendo las instrucciones del diagrama a continuación.

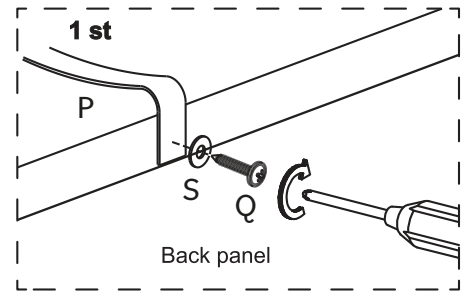
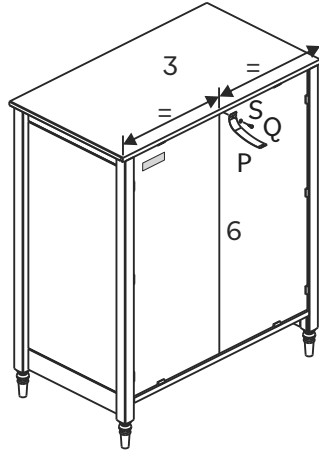

Étape / Paso 22

(FR) Dernière étape ! Insérez la douille en plastique (R) dans le mur. Fixez ensuite l'ancrage mural (P) au mur à l'aide de la rondelle (S) et de la vis (O).

(ES) ¡Último paso! Inserte el casquillo de plástico (R) en la pared. Luego, fije el anclaje de pared (P) a la pared con la arandela (S) y el tornillo (O).

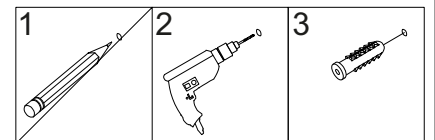
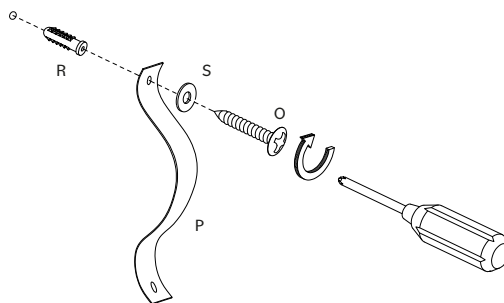

Avertissement

Des blessures graves, voire mortelles, peuvent survenir en cas de renversement de meubles. Pour éviter que le meuble ne bascule, nous recommandons de le fixer définitivement au mur. L'ancrage mural et les autres composants sont inclus dans ce produit. Assure-toi que les composants sont adaptés à tes murs avant l'installation, car différents matériaux de mur peuvent nécessiter différents types d'ancrages.

Le nom et l'adresse du fabricant responsable des composants anti-basculer ainsi que la date de production se trouvent sur l'étiquette au dos du meuble.

Advertencia

Pueden ocurrir lesiones graves o fatales debido a la caída de muebles. Para evitar que los muebles se caigan, recomendamos que se fijen permanentemente a la pared. El anclaje de pared y los herrajes están incluidos en este producto. Asegúrate de que los herrajes sean adecuados para tus paredes antes de la instalación, ya que diferentes materiales de pared pueden requerir diferentes tipos de anclajes.

El nombre y la dirección del fabricante responsable de los herrajes antivuelco y la fecha de producción se pueden encontrar en la etiqueta de la parte trasera de los muebles.

À démonter / Para desmontar



(FR)

S'il est nécessaire de démonter, retirez le Dovetail Lock (B) à l'aide d'un tournevis à tête plate.

(ES)

Si es necesario desmontarlo, retire el Dovetail Lock (B) con un destornillador de cabeza ranurada.

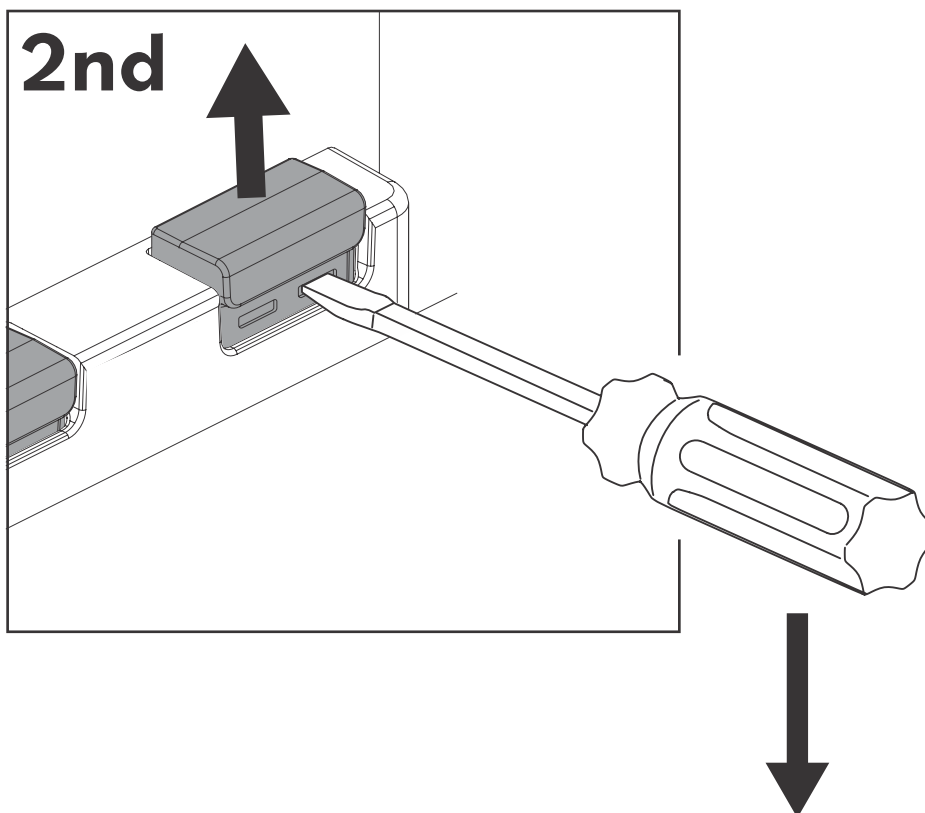
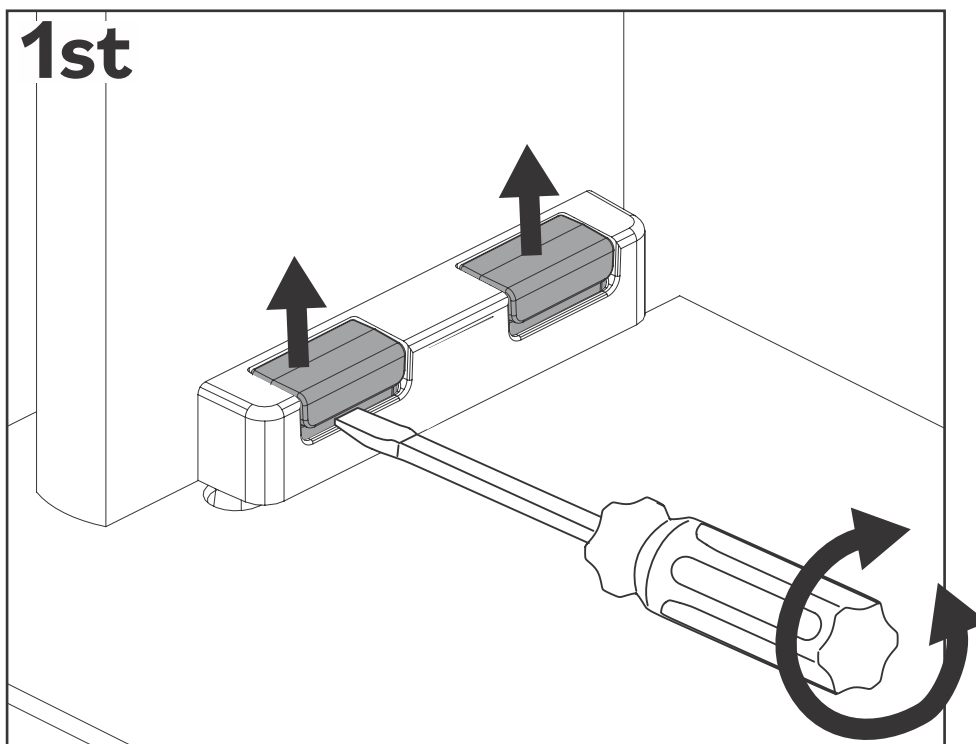

Tu as réussi ! Profite de ton nouveau Commode
à tiroirs!
¡Lo ha conseguido! ¡Disfrute de su nueva Cómoda
con cajones!

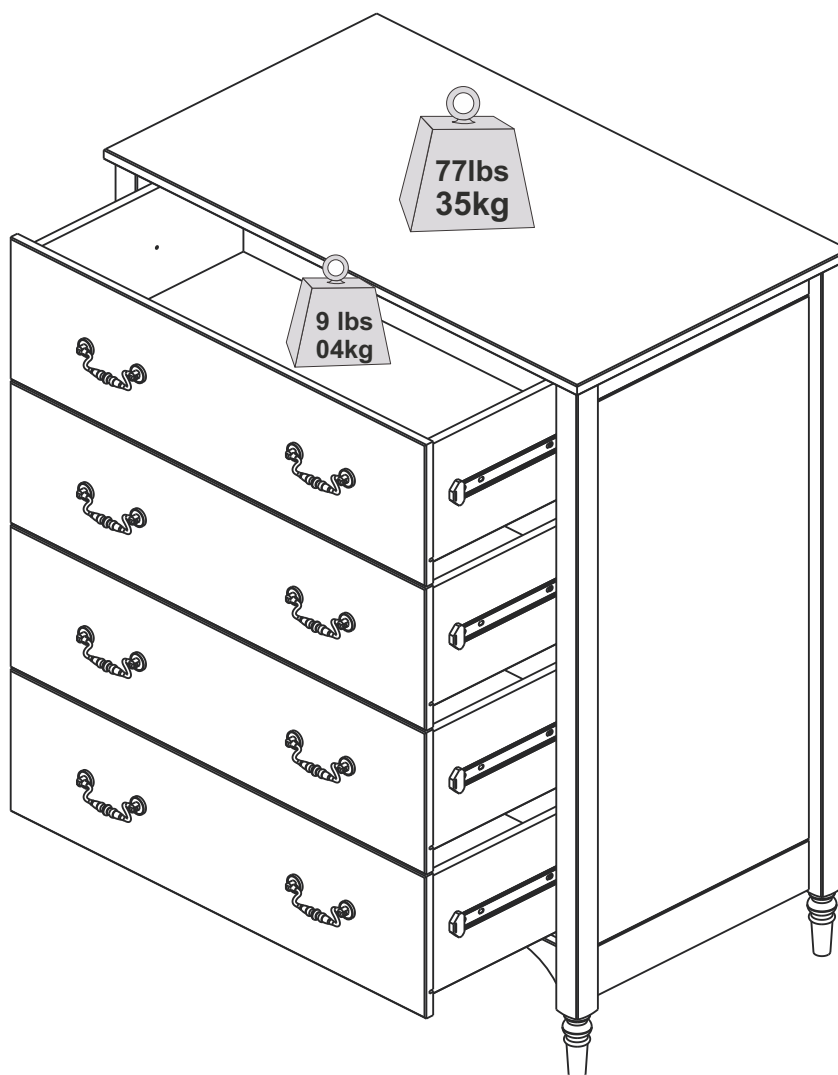

Bravo pour ton nouveau meuble !

¡Enhorabuena por sus nuevos muebles!