

SPEC SHEET

CellGuard™ 32-Phone Storage Cabinet

Product Specifications

Item Numbers	CHZZ001: Standard Cabinet CHZZ002: Cabinet with Wall-Mount Kit
Materials	Cabinet: Powder-coated steel Phone Holder Insert: PE foam with silkscreen slot markers Front Door Panel: Clear acrylic
Color	Black
Product Dimensions	Overall: 15" W x 9" D x 16.25" H Device Slots (top two rows): 0.71" W x 6.5" D x 3.62" H (each) Device Slots (bottom row): 0.83" W x 6.5" D x 3.62" H (each)
Product Weight	CHZZ001: 17.64 lbs. CHZZ002: 21.23 lbs.
Capacities	Device Capacity (top two rows): 22 phones up to 0.71" W x 6.5" D x 3.62" H Device Capacity (bottom row): 10 phones up to 0.71" W x 6.5" D x 3.62" H Weight Capacity: 30 lbs. (CHZZ002, wall-mounted)
Additional Features	Key-lockable door (includes two keys), see-through acrylic front door panel, grab handles, Kensington lock receptacle
Shipping	Item Number: CHZZ001 Shipping Dimensions: 19.91" W x 11.81" D x 19.29" H Shipping Weight: 19.84 lbs. Shipping Method: Ground Item Number: CHZZ002 Shipping Dimensions (box 1): 19.91" W x 11.81" D x 19.29" H Shipping Dimensions (box 2): 13.75" W x 10.0" D x 2.95" H Shipping Weight (box 1): 19.84 lbs. Shipping Weight (box 2): 1.75 lbs. Shipping Method: Ground
Assembly Required	CHZZ001: None CHZZ002: Installation and attachment of wall-mount bracket
Certifications/Testing	Drop test confirmed UPS/FEDEX shippable packaging
Warranty	Limited Lifetime

Product Dimensions

Cabinet (CHZZ001 and 002)

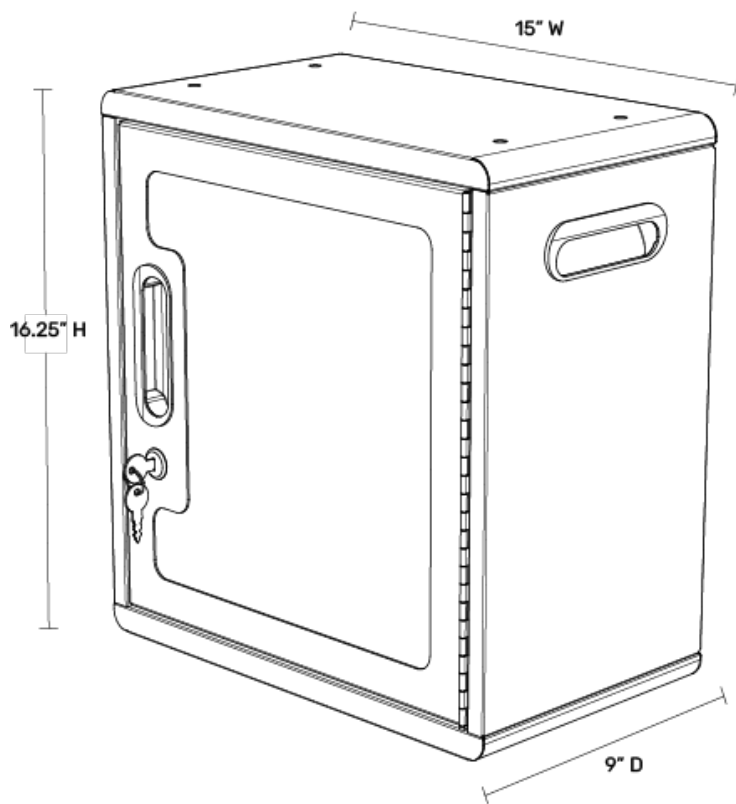

Wall Mount Bracket (CHZZ002 only)

