

# Bristol Dining Swivel Rocker Assembly Guide



## Tools Required



Cordless Drill



#2 Square Drive Bit



Allen Wrench (included)



Wrench

## Hardware Included



4 - 4" Buglehead Screws

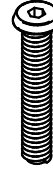

6 - 5/16" X 1/4" Allen Head Bolts



6 - 5/16" X 1/4" Allen Head Bolts



6 - 5/16" Flange Nuts



6 - 5/16" Lock Washers



6 - 5/16" Square Nuts

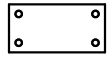

3 - Fiberglass Springs

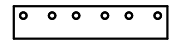

3 - Aluminum Plates

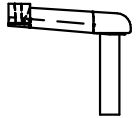

1 - Swivel Mechanism

## Step 1

Fasten the back to the seat by fitting the seat supports into the cutouts in the back legs. Using the #2 square drive bit, drive 4 - 4" buglehead screws into the predrilled holes in the back legs. You may need to reverse your drill several times before being able to pull the pieces tightly together.

*Note: Ensure that the outside surfaces of the back leg and seat support are even and are securely fastened as noted below!*



When tightening screws or lags, **DO NOT OVERTIGHTEN** to avoid stripping their hold on the material!

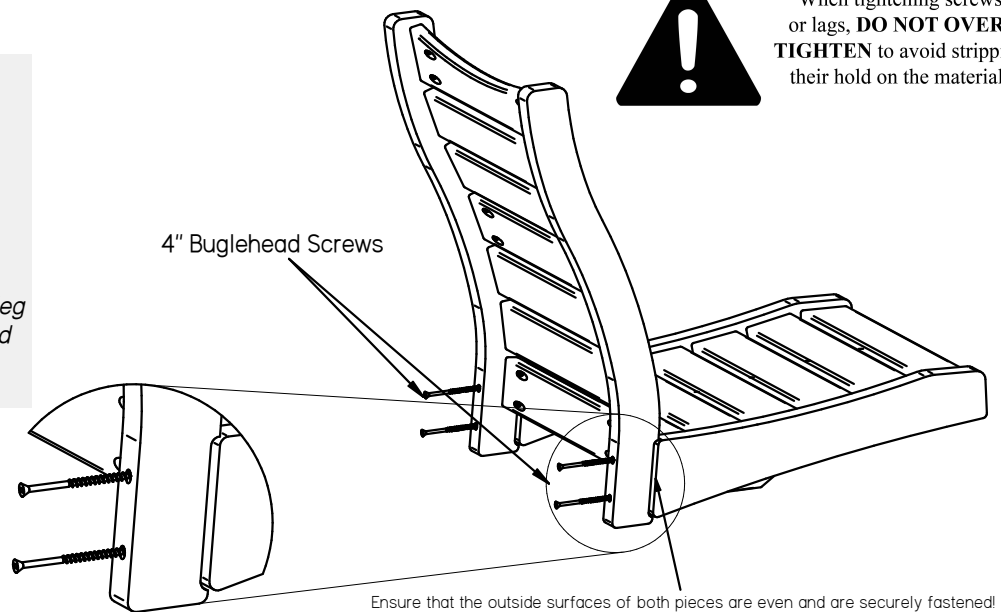

4" Buglehead Screws

Ensure that the outside surfaces of both pieces are even and are securely fastened!

Step 1 Detail

## Step 2

Using 6 - 5/16" x 1/4" Allenhead Bolts and 5/16" Flangenuts, fasten the 3-Fiberglass Springs and an Aluminum Plate to the bracket located under the seat. The Springs should point towards the front of the chair. Only hand tighten the nuts until all six bolts are installed, then align the springs and fully tighten.

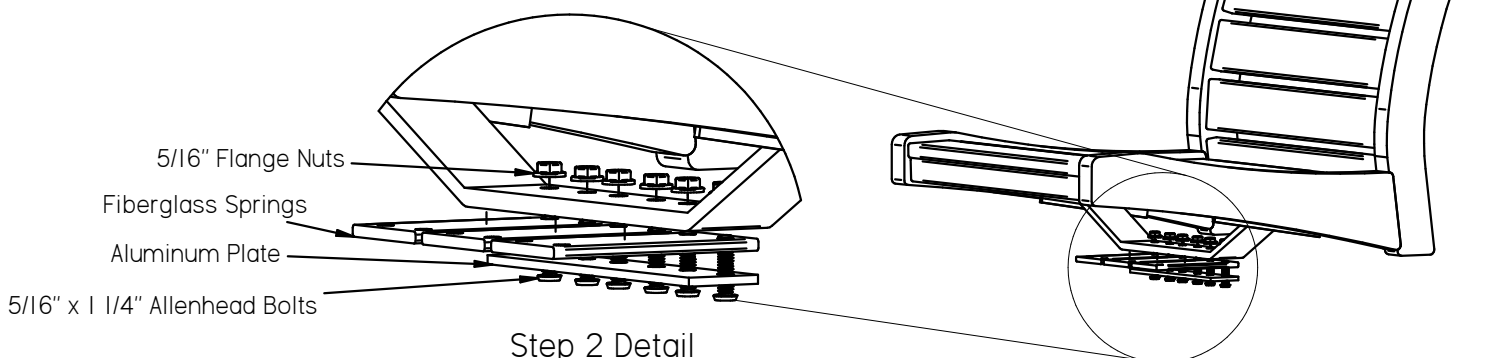

5/16" Flange Nuts

Fiberglass Springs

Aluminum Plate

5/16" x 1/4" Allenhead Bolts

Step 2 Detail

## Step 3

Fasten the Swivel Mechanism to the Fiberglass Springs, using 2 - Aluminum Plates, 6 - 5/16" x 1 3/4" Allenhead Bolts, Lock Washers and Square Nuts. Only hand tighten the bolts until all six are installed then fully tighten.

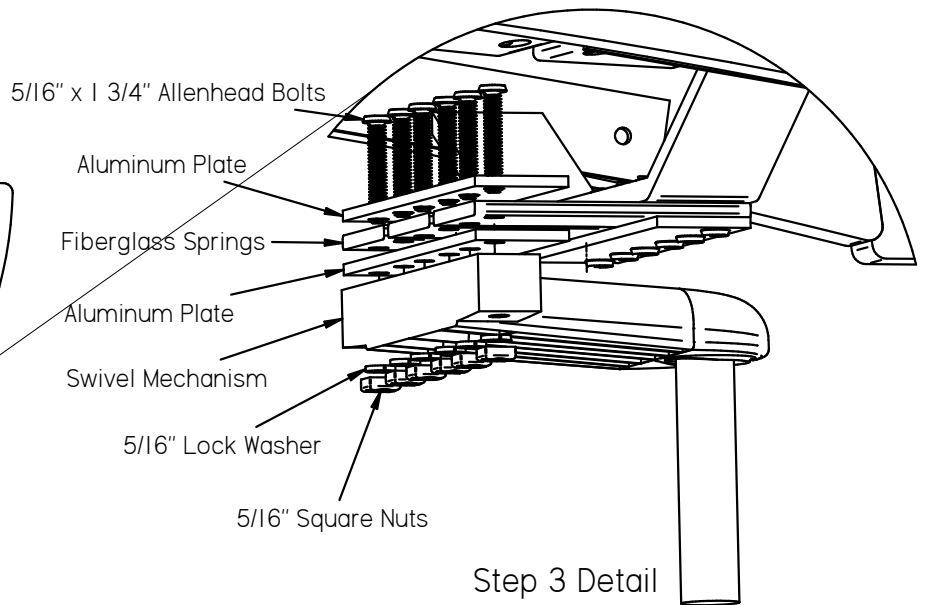
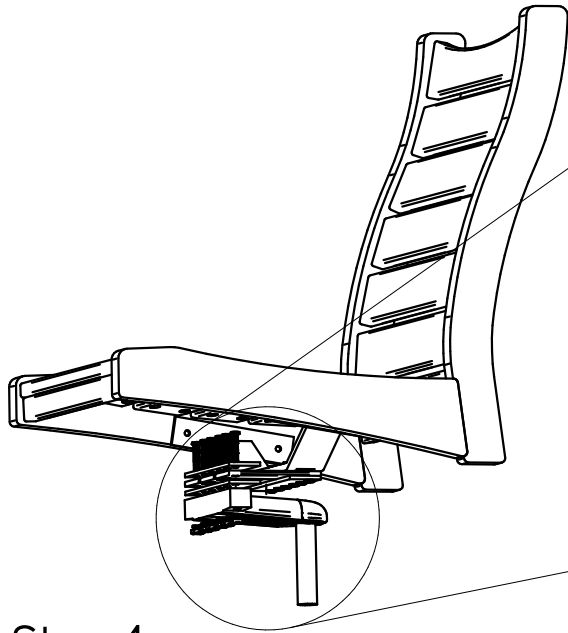

## Step 4

Lift the chair and set the swivel stem into the receiver of the base. Push firmly onto the chair until it sits securely in the receiver.

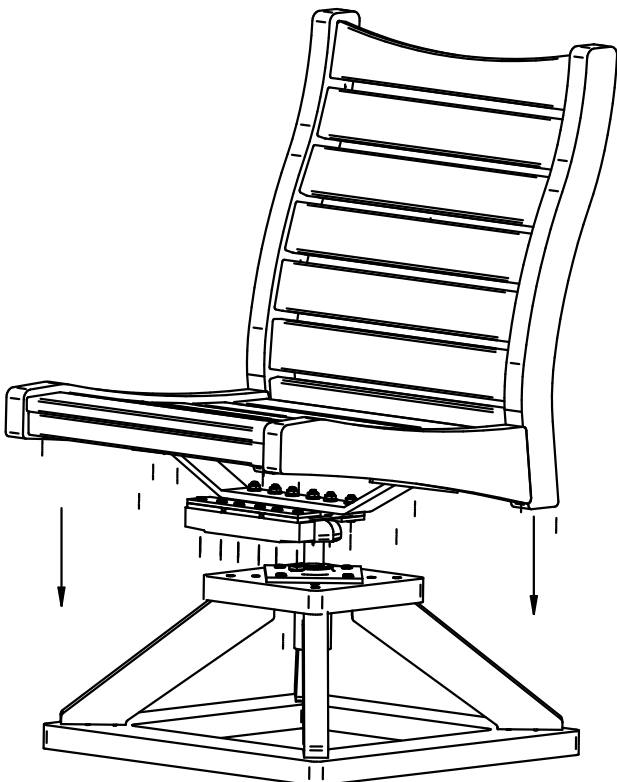

## Step 5

Install the arms rests on your swivel chair using the instructions and hardware provided with the Arm Kit.

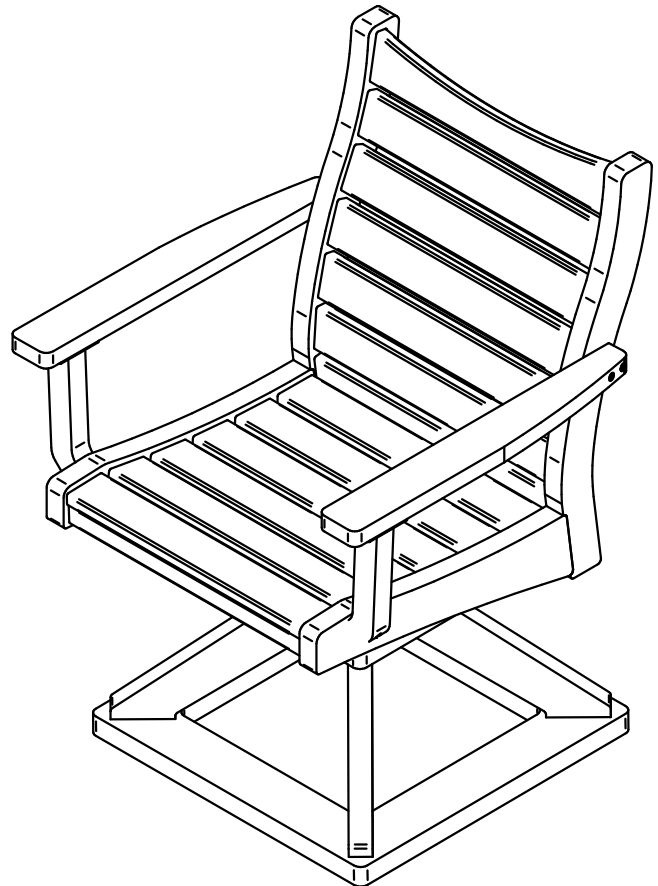

**DO NOT USE A SWIVEL CHAIR WITHOUT THE ARMS RESTS INSTALLED!**