

Item No.
94427 R1

Printer Stand
Stand pour imprimante
Soporte para la impresor

TH

Control No.
N° de contrôle **R1** -
de control

To receive free replacement, Control No. and Proof-of-Purchase from an authorized dealer/retailer MUST be provided with request within 60 days from date of purchase.

Pour obtenir un remplacement gratuit, le numéro de contrôle et la preuve d'achat auprès d'un concessionnaire/magasin autorisé DOIVENT être fournis avec une demande soumise dans les 60 jours suivant la date d'achat.

Para recibir un reemplazo gratis, numero de Control y prueba de compra de un comerciante/vendedor autorizado, DEBE ser recibido dentro de 60 días desde la fecha de compra.

IMPORTANT! Please provide CONTROL NO. to ensure replacement parts will properly fit unit on hand.

IMPORTANT! Fournir N° de CONTRÔLE pour assurer que les pièces de recharge s'adaptent correctement à l'unité en question.

IMPORTANT! Favor de proporcionar el NUMERO DE CONTROL para garantizar que las piezas de reemplazo ajuste corrcctame su productor.

Missing parts request: To obtain replacement part(s), fill in quantity in the "missing" box under the "Parts List" section. Complete contact and shipping information in address box accurately and clearly. Please allow 7-14 days for delivery.

Demande de pièces manquantes: Pour obtenir une (des) pièce(s) de remplacement, remplissez la case « manquant » sous la section « Liste des pièces ». Fournissez vos coordonnées et informations d'expédition dans la case Adresse de manière claire et précise. La livraison aura lieu dans un délai de 7 à 14 jours.

Petición de partes perdidas: Para obtener parte(s) de reemplazo, llené en número la cantidad en el cuadro de "missing" debajo de "Lista de partes" sección. Llené su información de contacto y envío en el cuadro de dirección clara y correcta. Por favor permita 7-14 días para envío.

Name - Nom - Nombre

Address - Adresse - Dirección

City/State/Zip - Ville/Province/Code postal - Ciudad/Estado/Zona Postal

Phone - Téléphone - Teléfono

Email

Reason of replacement part(s)
Raison de(s) pièce(s) de remplacement
Razón del reemplazo la parte(s):

- Missing/Manquant/Ausente
- Damaged/Endommagé/Dañado
- Not Fit/Ne rentre pas/No ajusta
- Other/Autre/Otro:

Provide Details/Fournis détails/
Proporcionar detalles:

Parts List - Liste des pièces - Lista de partes

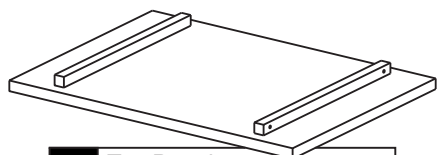

A	Top Panel Panneau supérieur Tapa	Quantity Quantité Cantidad	1	Replace Remplacer Reemplazar	
----------	--	----------------------------------	---	------------------------------------	--

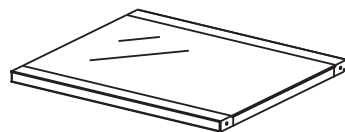

B	Middle Panel Panneau moyenne Panel de en medio	Quantity Quantité Cantidad	1	Replace Remplacer Reemplazar	
----------	--	----------------------------------	---	------------------------------------	--

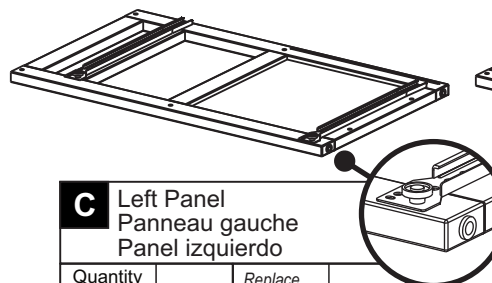

C	Left Panel Panneau gauche Panel izquierdo	Quantity Quantité Cantidad	1	Replace Remplacer Reemplazar	
----------	---	----------------------------------	---	------------------------------------	--

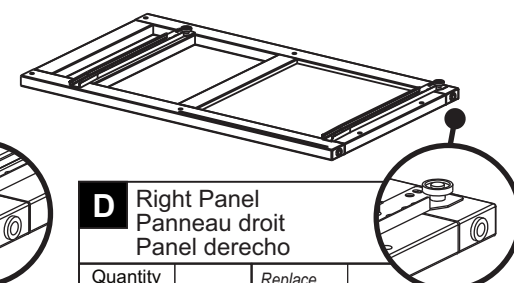

D	Right Panel Panneau droit Panel derecho	Quantity Quantité Cantidad	1	Replace Remplacer Reemplazar	
----------	---	----------------------------------	---	------------------------------------	--

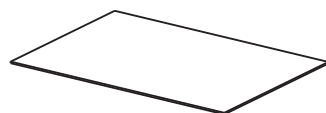

E	Back Panel Panneau arrière Panel trasero	Quantity Quantité Cantidad	1	Replace Remplacer Reemplazar	
----------	--	----------------------------------	---	------------------------------------	--

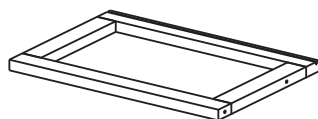

F	Bottom Frame Cadre inférieur Marco de abajo	Quantity Quantité Cantidad	1	Replace Remplacer Reemplazar	
----------	---	----------------------------------	---	------------------------------------	--

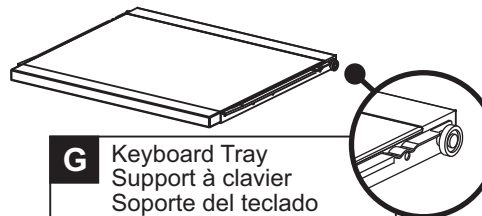

G	Keyboard Tray Support à clavier Soporte del teclado	Quantity Quantité Cantidad	1	Replace Remplacer Reemplazar	
----------	---	----------------------------------	---	------------------------------------	--



H	Metal Rod Tige en métal Barra de metal	Quantity Quantité Cantidad	2	Replace Remplacer Reemplazar	
----------	--	----------------------------------	---	------------------------------------	--

94427 R1

Printer Stand
Stand pour imprimante
Soporte para la impresor

TH

Control No.
N° de contrôle R1 -
de control

IMPORTANT! Please provide CONTROL NO. to ensure replacement parts will properly fit unit on hand.

IMPORTANT! Fournir N° de CONTRÔLE pour assurer que les pièces de recharge s'adaptent correctement à l'unité en question.

IMPORTANTE! Favor de proporcionar el NUMERO DE CONTROL para garantizar que las piezas de reemplazo ajuste corrctame su productor.

Name - Nom - Nombre

Address - Adresse - Dirección

City/State/Zip - Ville/Province/Code postal - Ciudad/Estado/Zona Postal

Phone - Téléphone - Teléfono

Email

Reason of replacement part(s)
Raison de(s) pièce(s) de remplacement
Razón del reemplazo la parte(s):

- Missing/Manquant/Ausente
- Damaged/Endommagé/Dañado
- Not Fit/Ne rentre pas/No ajusta
- Other/Autre/Otro:

Provide Details/Fournis détails/Proporcionar detalles:

Parts List - Liste des pièces - Lista de partes

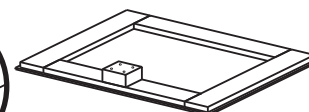
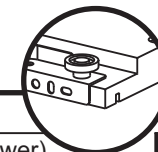
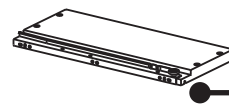
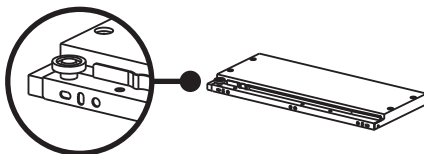
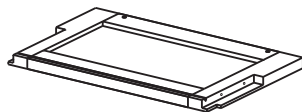
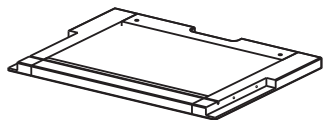

I	Front Panel (Drawer) Panneau avant (tiroir) Panel delantera (cajón)
Quantity Quantité Cantidad	1 Replace Remplacer Reemplazar

J	Back Panel (Drawer) Panneau arrière (tiroir) Panel posterior (cajón)
Quantity Quantité Cantidad	1 Replace Remplacer Reemplazar

K	Left Panel (Drawer) Panneau gauche (tiroir) Panel izquierdo(cajón)
Quantity Quantité Cantidad	1 Replace Remplacer Reemplazar

L	Right Panel (Drawer) Panneau droit (tiroir) Panel derecho (cajón)
Quantity Quantité Cantidad	1 Replace Remplacer Reemplazar

M	Bottom Panel (Drawer) Panneau inférieur (tiroir) Panel de abajo (cajón)
Quantity Quantité Cantidad	1 Replace Remplacer Reemplazar



N	Wheel Roulette Rueda
Quantity Quantité Cantidad	2 Replace Remplacer Reemplazar

O	Locking Wheel Roulette à verrouillage Rueda con cerrójo
Quantity Quantité Cantidad	2 Replace Remplacer Reemplazar

P	Wheel - Mounting Plate Roulette - plaque monture Rueda - placa de montaje
Quantity Quantité Cantidad	1 Replace Remplacer Reemplazar

Q	Wood Plug** Chevilles en bois** Tapón de madera**
Quantity Quantité Cantidad	12 Replace Remplacer Reemplazar

R	Screw Hex Vis hex Tornillo hex
Quantity Quantité Cantidad	12 Replace Remplacer Reemplazar

For Wheel
Pour roulette
Para rueda



For Drawer
Pour tiroir
Para cajón



S	Small Screw (Phillips)* Vis petite (phillips)* Tornillo pequeño (phillips)*
Quantity Quantité Cantidad	4 Replace Remplacer Reemplazar

T	Screw (Long Phillips)* Vis (long Phillips)* Tornillo (largo Phillips)*
Quantity Quantité Cantidad	8 Replace Remplacer Reemplazar

Hex Wrench Clé hexagonable Llave hexagonal	
Quantity Quantité Cantidad	1 Replace Remplacer Reemplazar

- * Screw Driver is required and not included in the package.
- * Un tournevis est nécessaire mais n'est pas inclus avec cet ensemble.
- * Se requiere desarmador de cruz y no viene incluido.

- ** Tip: Insert wood plugs after finishing assembling the unit.
- ** Conseil: fixer les tampons de bois après avoir assemblé l'unité.
- ** Consejo: ponga los tapones de madera despues de la asamblea de la unidad.

1

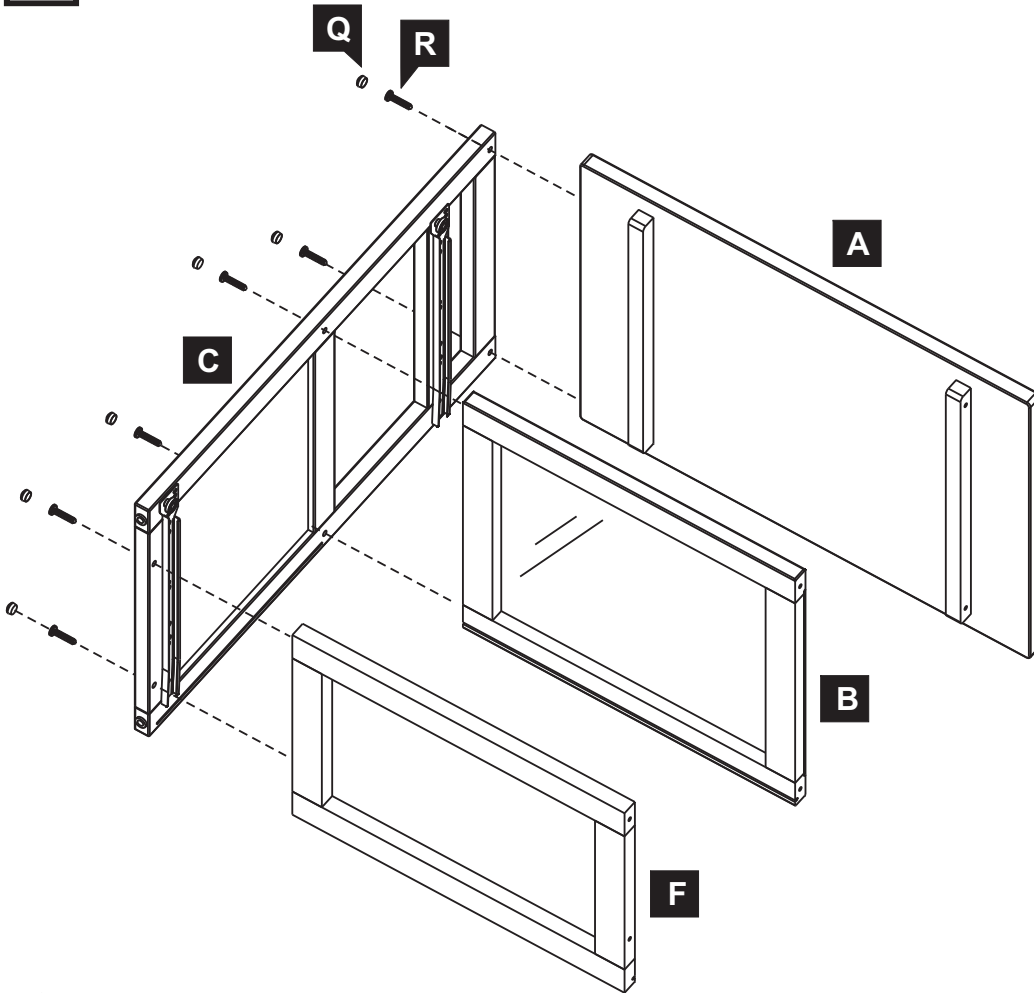

2

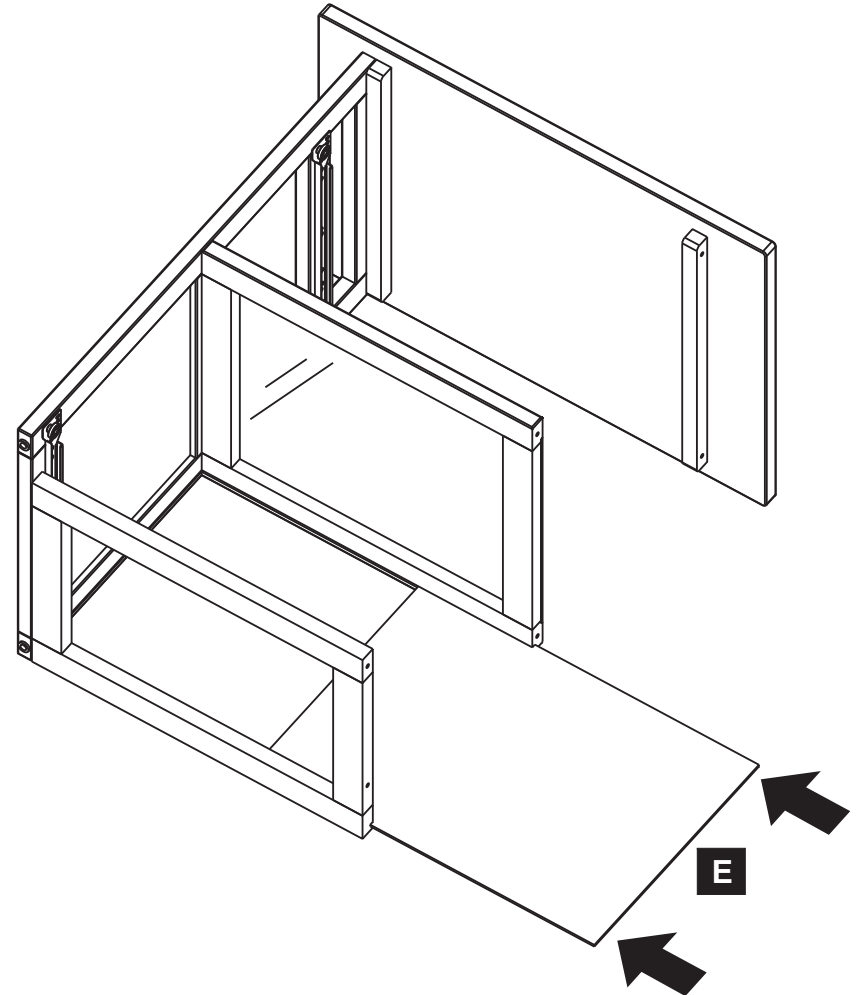

- ** Tip: Insert wood plugs after finishing assembling the unit.
- ** Conseil: fixer les tampons de bois après avoir assemblé l'unité.
- ** Consejo: ponga los tapones de madera después de la asamblea de la unidad.



Recommend to have helping hands for this step.
demandez de l'aide pour cette étape.
Se recomienda que le ayuden para este paso.

3

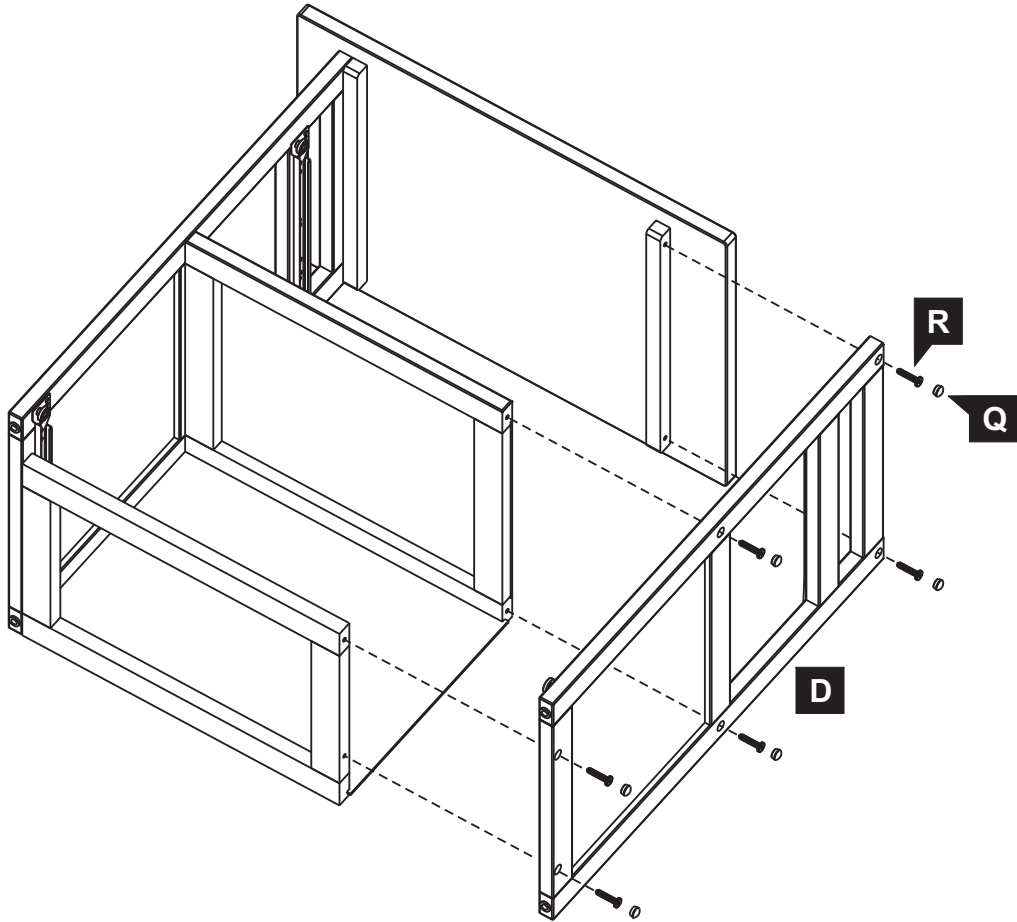

4

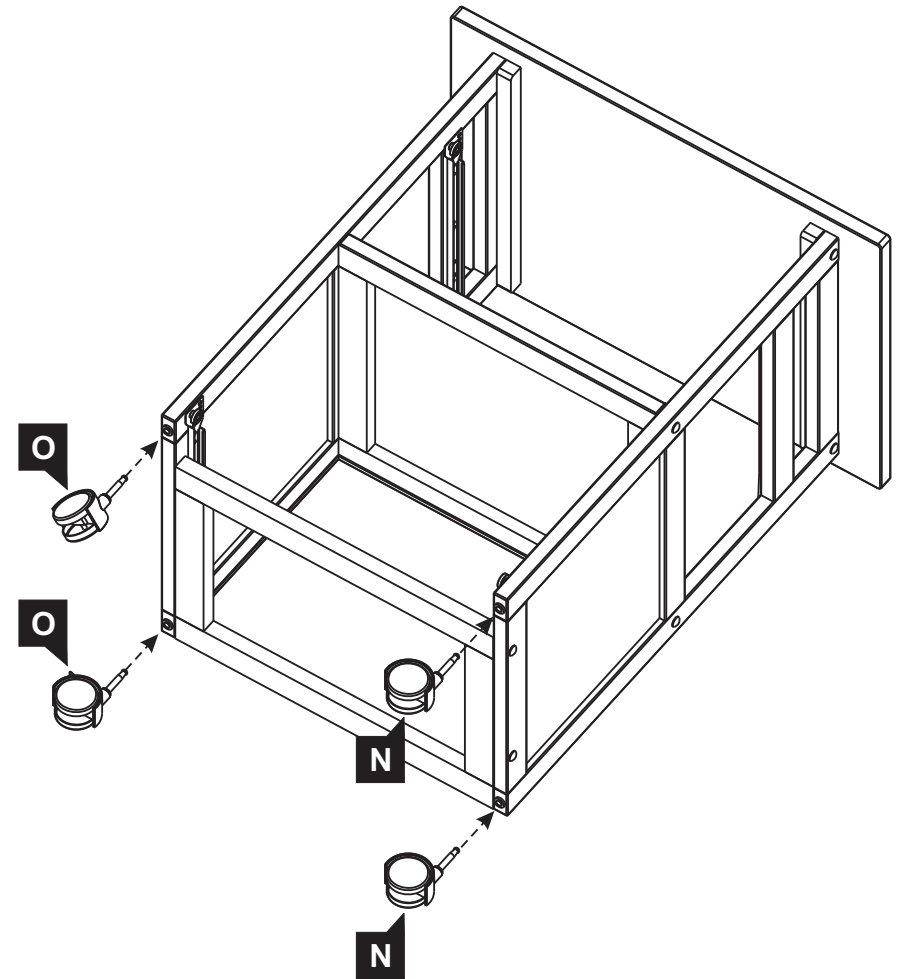

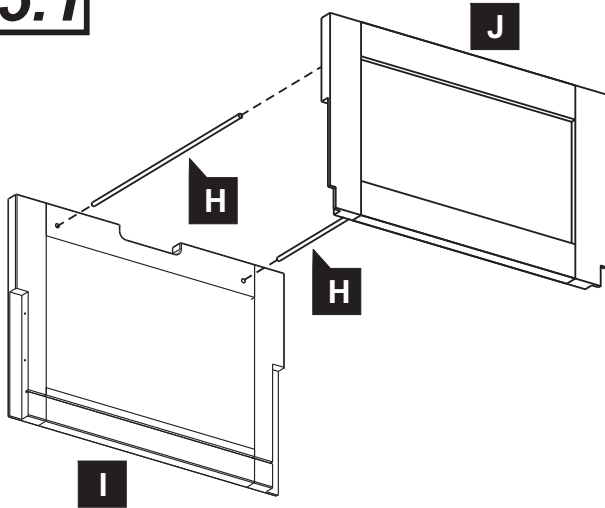
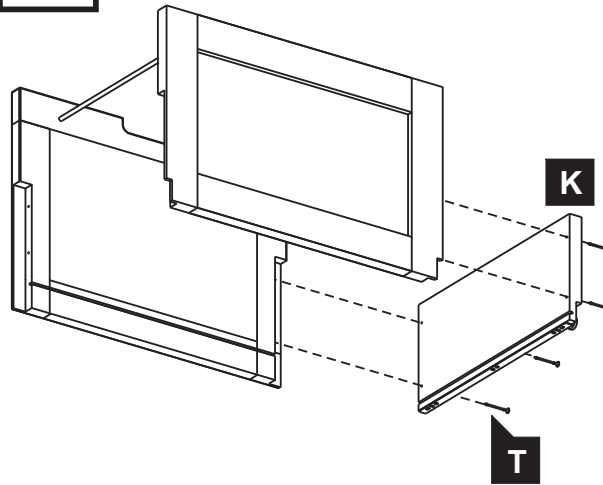
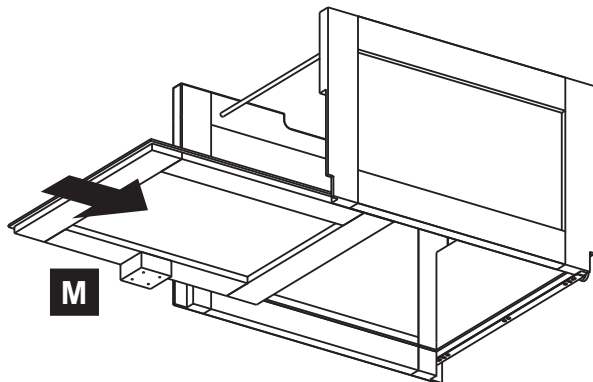
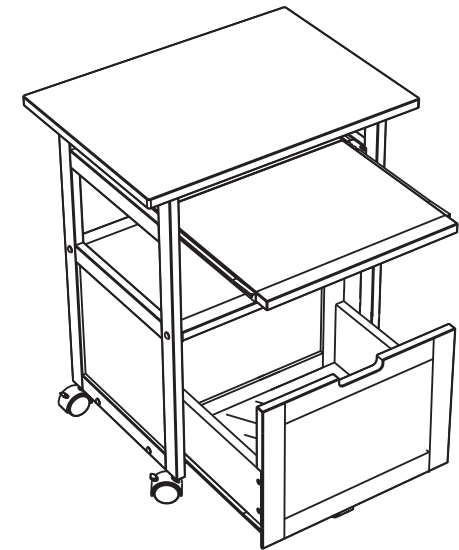
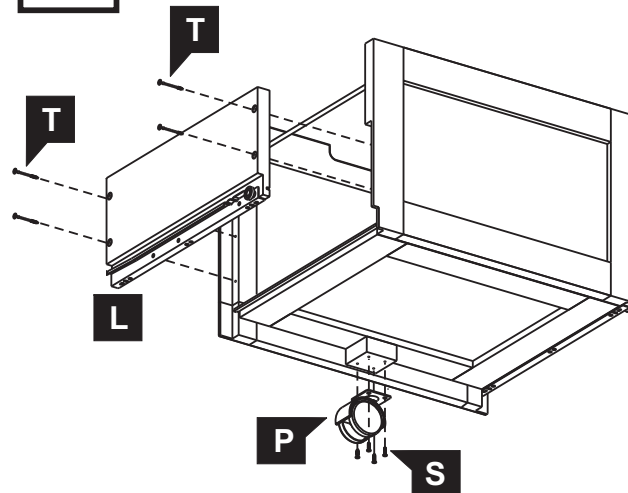
Item No. **94427 R1****Assembly Instructions - Instructions d'assemblage - Instrucciones de ensamblaje****5** Drawer
Tiroir
Gaveta**5.1****5.2****5.3****5.4**

***Alternate installation:**
Drawer can be installed without metal rods.

***Installation alternatif:**
Tiroir peut être installé sans tiges en métal.

***Instalación Alternativa:**
Gaveta se puede instalar sin barras de metal.

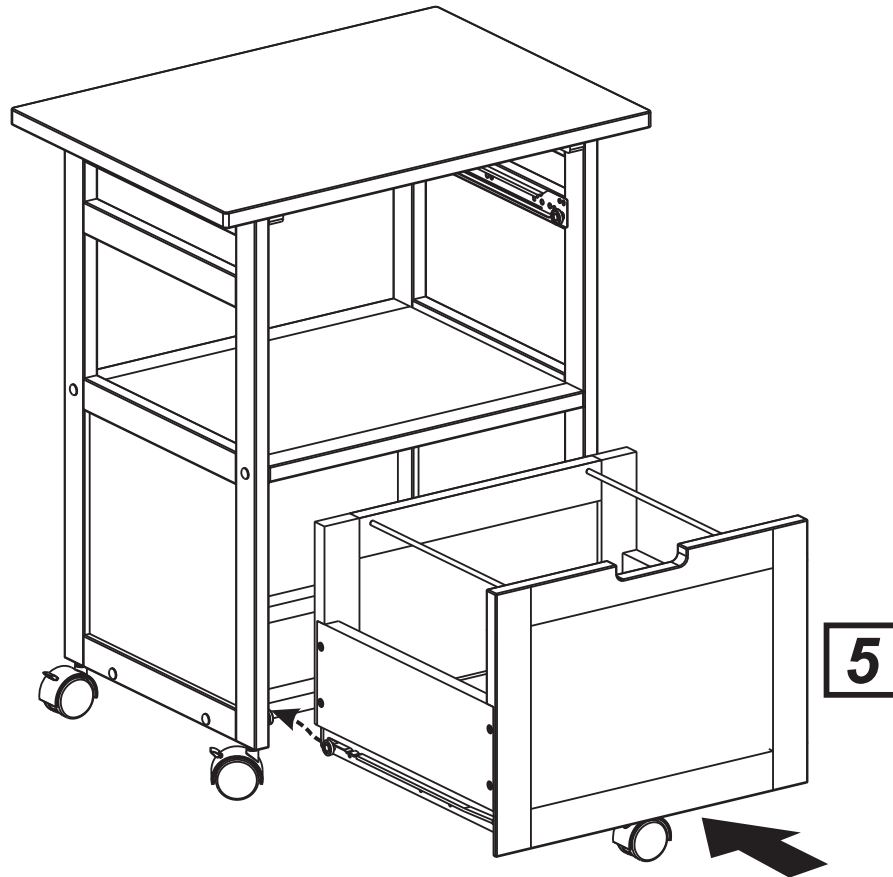
6**5****7****G****Care instructions:**

To clean, wipe with wet cloth and dry thoroughly. Use mild soap if necessary. Avoid use of commercial waxes or polishes or abrasive cleaning materials.

Instructions d'entretien:

Pour nettoyer, essuyez avec un linge humide et séchez à fond. Utilisez un savon doux au besoin. Évitez d'utiliser des cires ou produits à polir de type commercial ou des matériaux de nettoyage abrasifs.

Instrucciones para el cuidado:

Para limpiar, frótelo con algo húmedo y séquelo bien. Use un jabón suave si es necesario. Evite el uso de ceras o pulidores comerciales o materiales abrasivos.