

PRODUCT MANUAL



ATTENTION! PLEASE READ THESE INSTRUCTIONS BEFORE USING THIS DEVICE

PRODUCT MANUAL



NOTICE:

If your package is missing parts or you are having issues with install, please call us directly. Our customer service team will address any questions or concerns you may have. Have this manual open and ready for reference.



SAFETY

To reduce risk of injury when installing & using the chair, follow these precautions:

- Read all of these instructions before installing and using your salon chair.
- It is helpful to have 2 people install and turn the chair upright after installing.
- Do not over-extend the bed and The weight of the person should not exceed 150 kg, creating the risk of falls or tipping the chair, and its occupant over, resulting in injury

OTHER ITEMS YOU WILL NEED (not included)

- Hand Tools: Wrench, Rubber Mallet, Screwdriver (Phillips), Sturdy box

PARTS & FEATURES

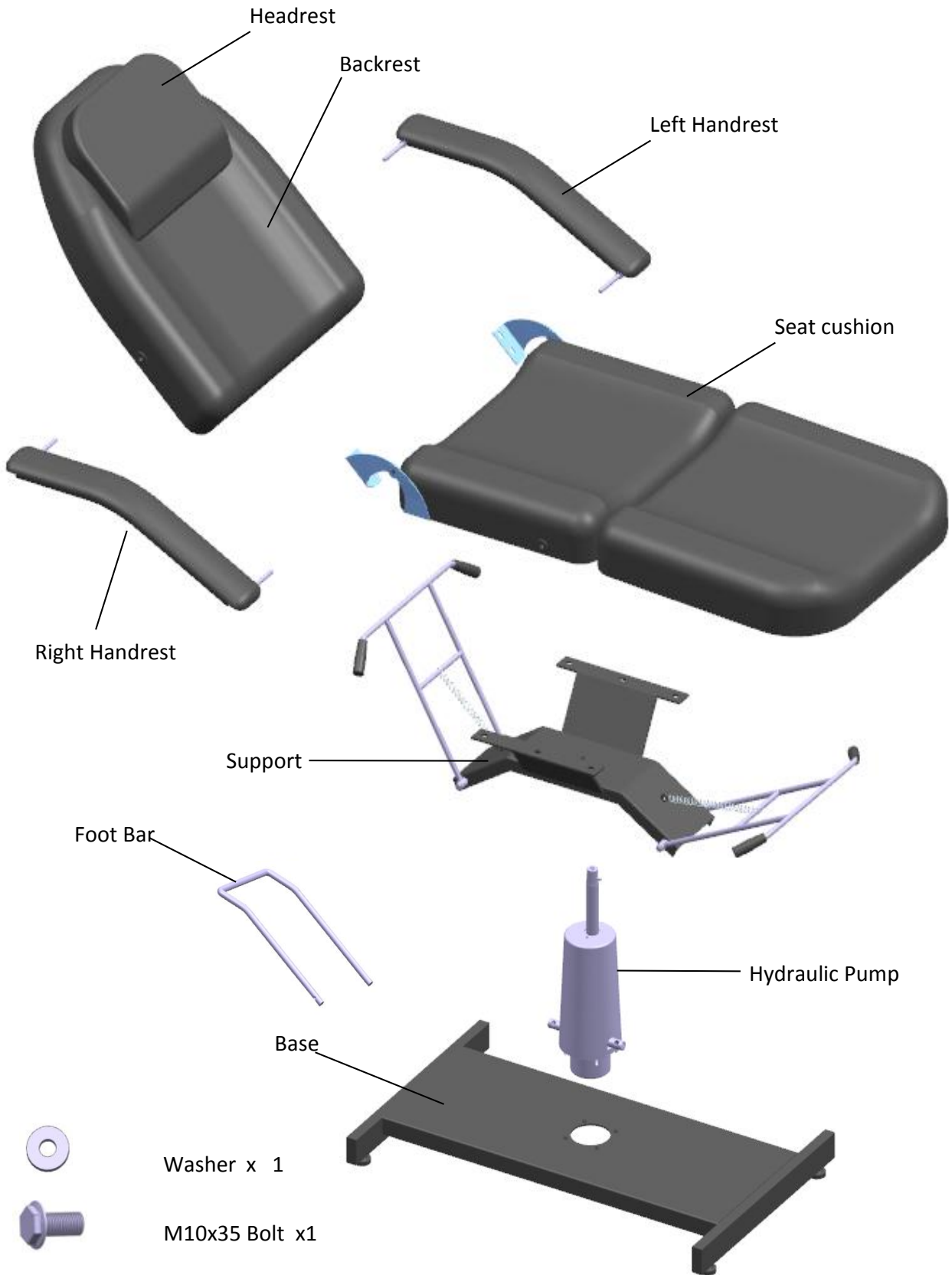

Washer x 1



M10x35 Bolt x1



M6 Locking nut x 4



4mm wrench x1

Installation instruction

First: Install Pump to Base

- Parts Needed: Base + Pump + 4 Locking Nuts + Wrench

Step 1. Insert threaded bolts on bottom of Pump into holes on middle of Base. Tighten 4 locking nuts onto threaded bolts. (Easiest when set on side, supported by a sturdy object.)

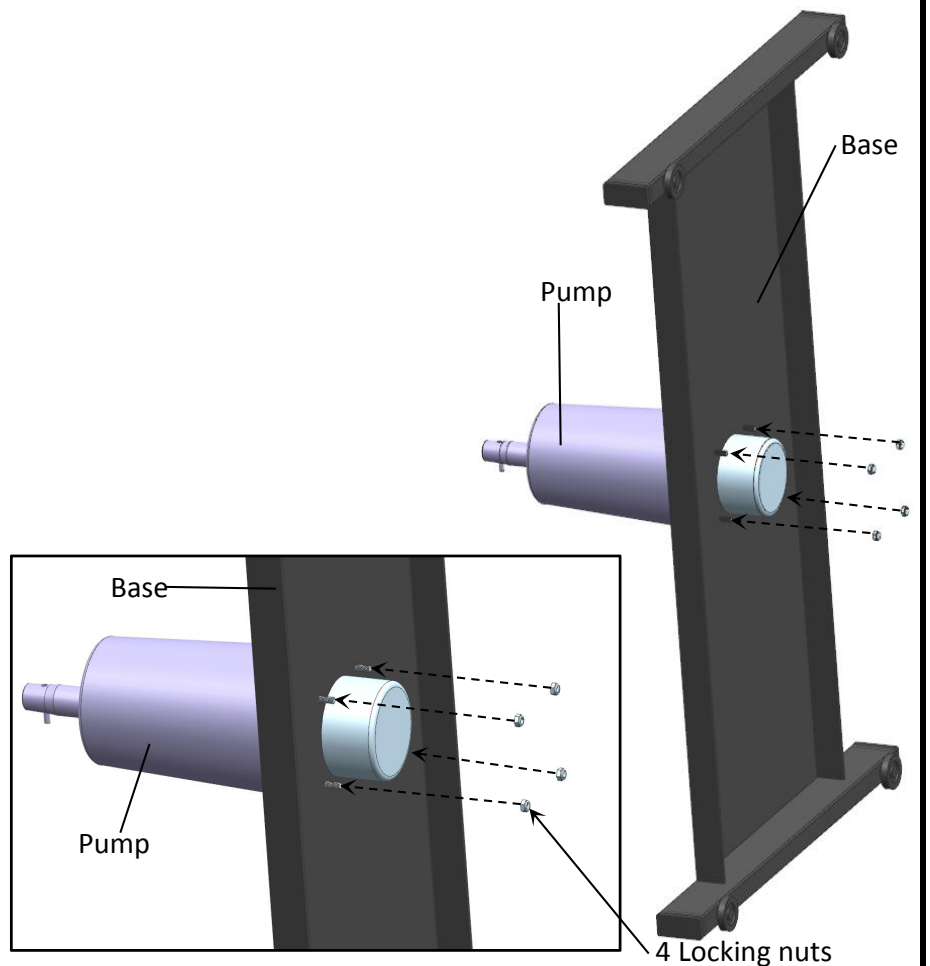

Second: Assemble Foot Bar to Assembled Hydraulic Pump & Base

- Parts Needed: Foot Bar + Assembled Base & Pump + Allen Wrench

Step 1. Place assembled Base & Pump on **floor**. Use Allen Wrench to loosen the screws in the crossbar. See photo besides.

Insert Foot Bar into the holes of the crossbar. (May require slightly squeezing ends of Foot Bar towards each other, and some maneuvering for the bar ends to go into place.)

Step 2. Tighten the set screws to **firmly** hold the Foot Bar in place.

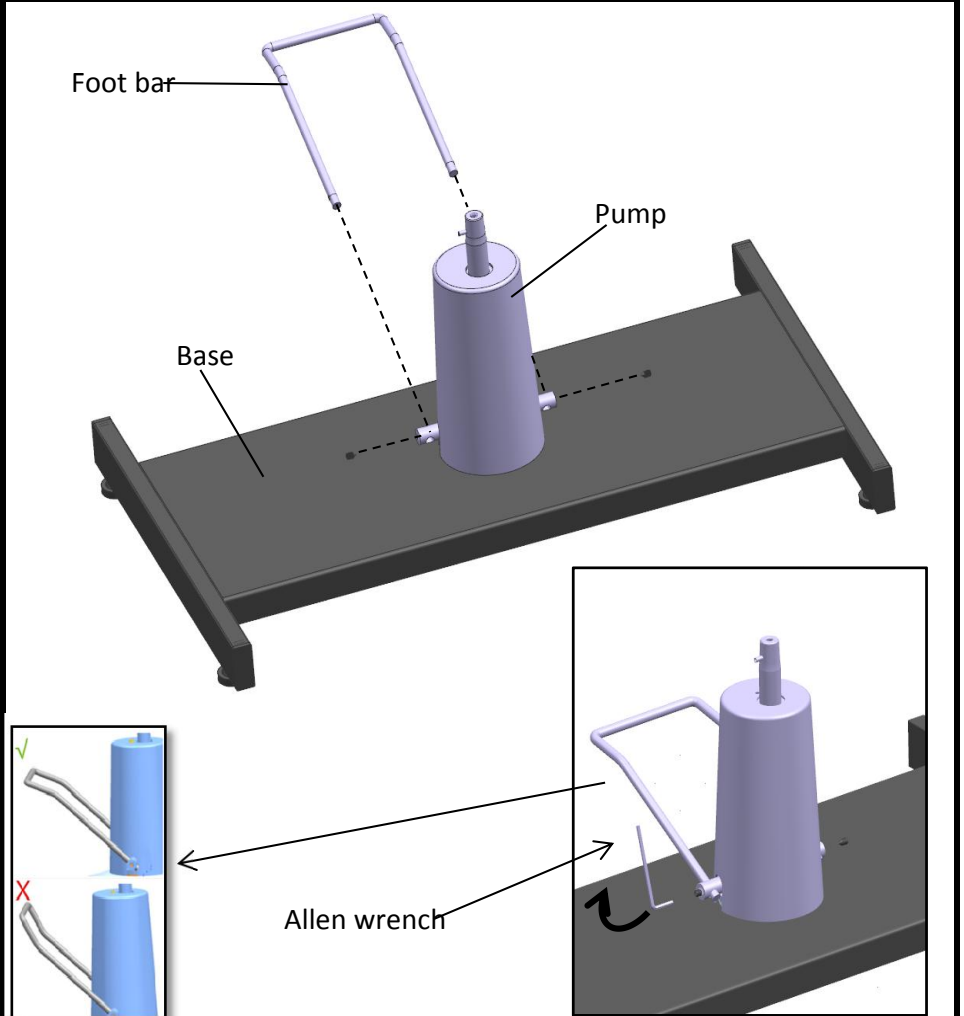

Third: Assemble backrest to seat cushion

- Parts Needed: Seat cushion + Backrest
- Step 1. remove 4 bolts which fixed on the backrest
- Step 2. Match the metal joining parts of seat cushion with 4 holes of the backrest
- Step 3. Use 4 bolts to tighten by wrench
- Step 4: Remove the iron sheet on the rack

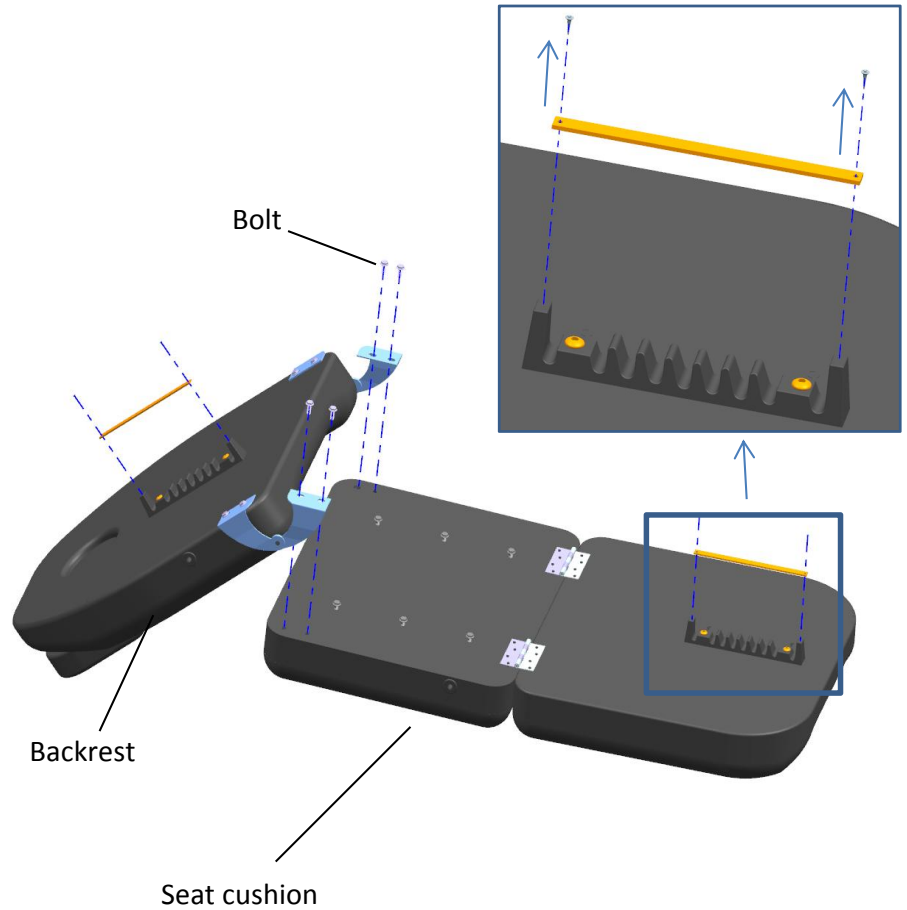

Fifth: Installation support to Seat cushion

- Parts needed :Support + Seat cushion
- Step 1 .Remove 6 bolts which pre-fixed in the Seat cushion
- Step 2 . Connect the holes of support to be matched with holes on the seat cushion by the loosen bolts, Then tighten them
- Step 3 .Insert The metal poles at both ends of the support into the tooth of rack, please take reference photo 1
- Step 4 .Hang one end of the spring on the nut which welded to the support and the other end on the metal pole, please take reference photo 2

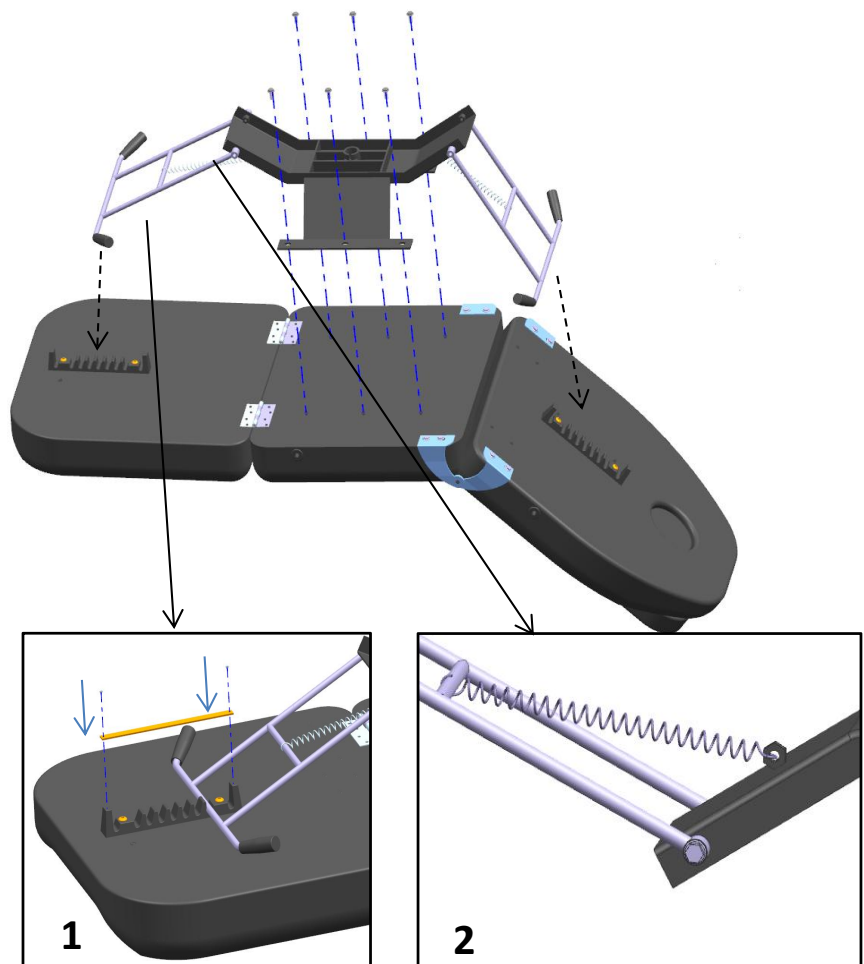

Install the iron sheet on the rack

Fourth : Set Seat & Backrest onto Hydraulic Pump & Base

Step 1. Locate the slot in the short column under the Seat. Align this slot with the black pin at the top of hydraulic pump.

Step 2. Set assembled Seat & Backrest onto assembled Hydraulic Pump & Base and press down.

Step 1. Insert threaded bolt through the hole of support into the hole on top of pump. Tighten

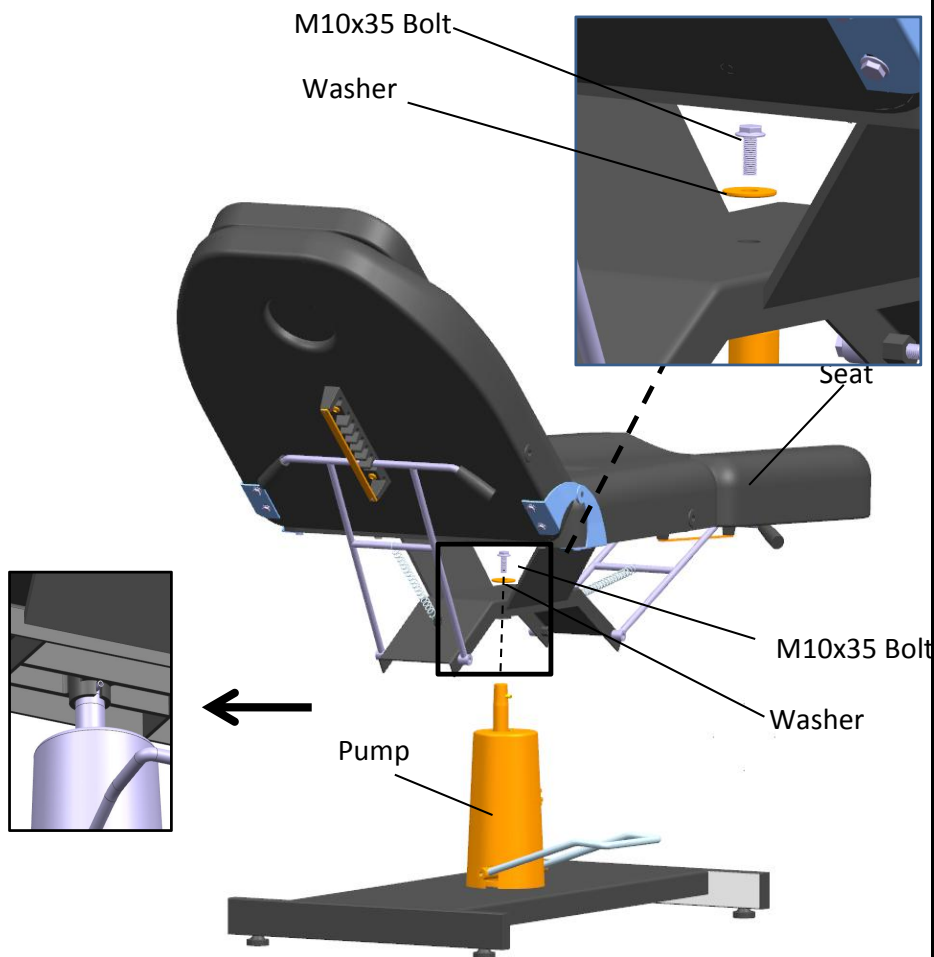

Fifth: Assemble armrest (F) to the backrest (B) and seat cushion (A)

1: putting the chair up right

2: Insert two armrests to the holes on each sides of chair, please follow up the diagram besides

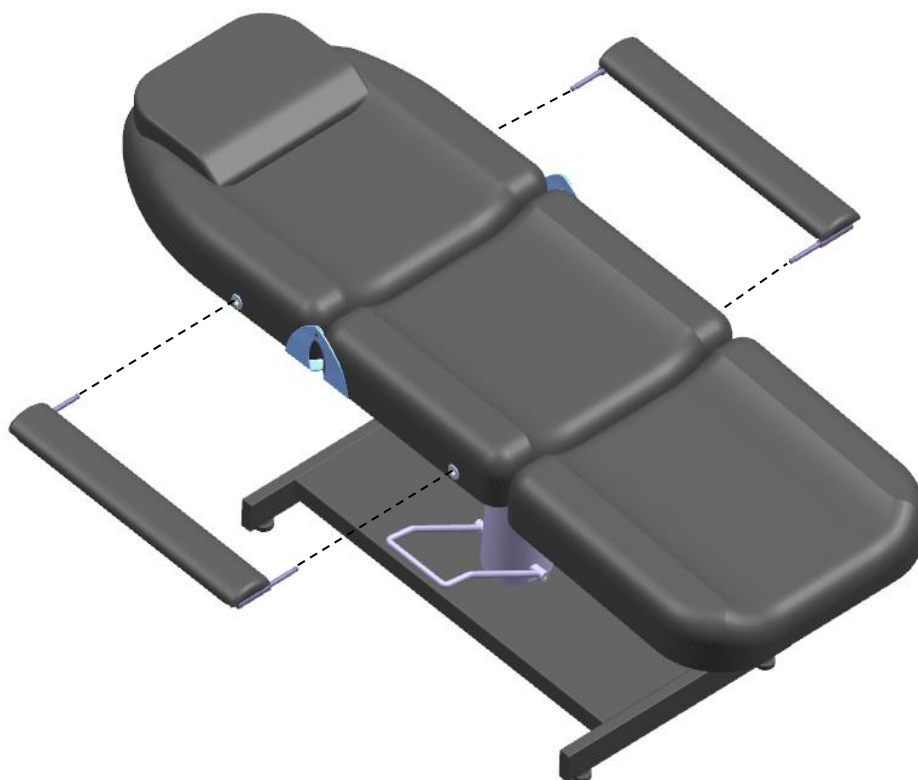

OPERATING THE CHAIR

Raising and Lowering the Chair

- Step down on the Foot Bar repeatedly to raise the chair to the desired height.
- Do not over-extend the chair, creating the risk of falls or tipping the chair and its occupant over, resulting in injury
- Step down and hold the Foot Bar to allow chair to lower.
- Hold the Foot Bar up to lock the chair .

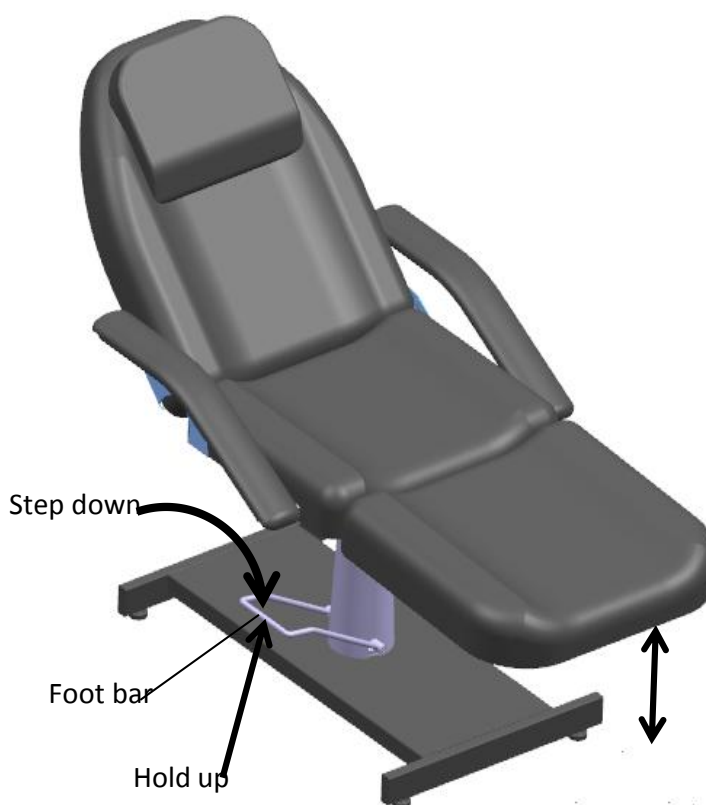

Recline the Backrest and the Seat cushion

- Adjusting the two support bars on the support to match the two racks, which can adjust the tilt of the backrest and the Seat cushion.



Notice!

- Do not over-extend the chair (0~150kg), creating the risk of falls or tipping the chair and its occupant over, resulting in injury
- When moving the adjustment support rod, it must not exceed the gear on both sides of the rack

