

ASSEMBLY INSTRUCTION

WAVE PATTERN CURVE BACK OFFICE CHAIR WITH TILT MECHANISM

MECHANISM

A Gas Lift

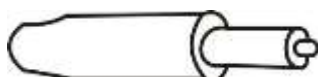

1pc

B Pentagonal Feet



1pc

C Caster



5pcs

D Seat



1pc

E Base Cap



1pc

F Bracket With Handle

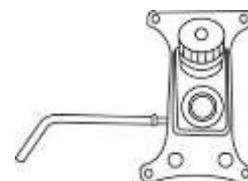

1pc

G Bolt
M6 x 20mm

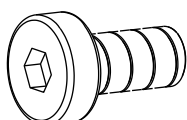

4pcs

H Allen Wrench
M6

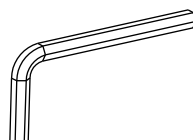

1pc



This page lists all the contents included in the box. Please take the time to identify the hardware as well as the individual components to this product. As you unpack and prepare for assembly, place the contents on a carpeted or padded area to protect them from damage.

1

Attach Caster (C) to Pentagonal Feet (B) as shown.

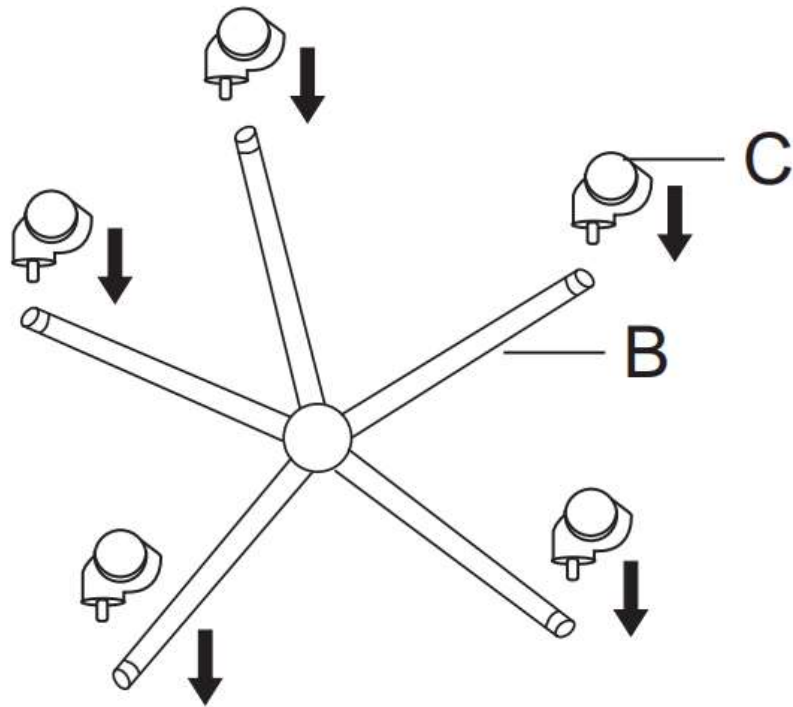

2

Insert Gas Lift (A) and Base Cap (E) into assembled base carefully as shown.

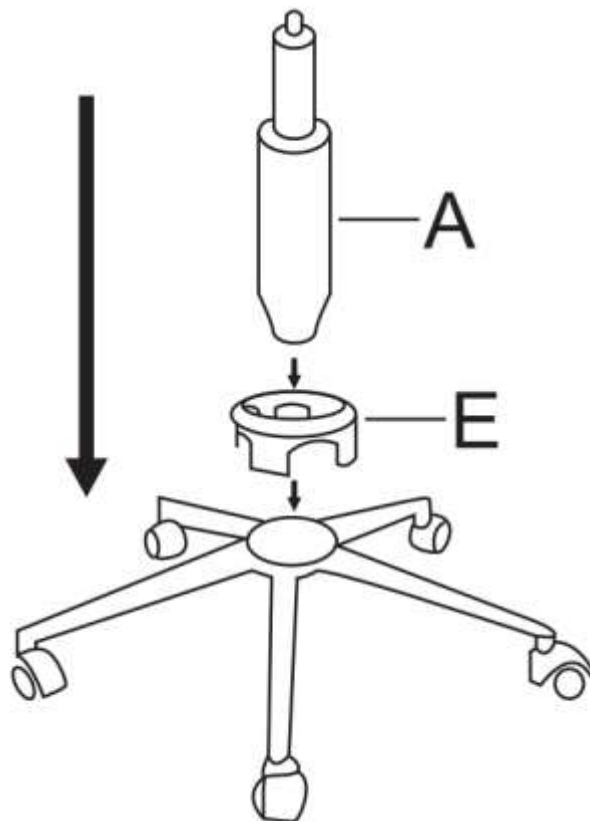

3 Attach Bracket With Handle (F) to Seat (D) by using Bolt (G) and Allen Wrench (H) as shown.

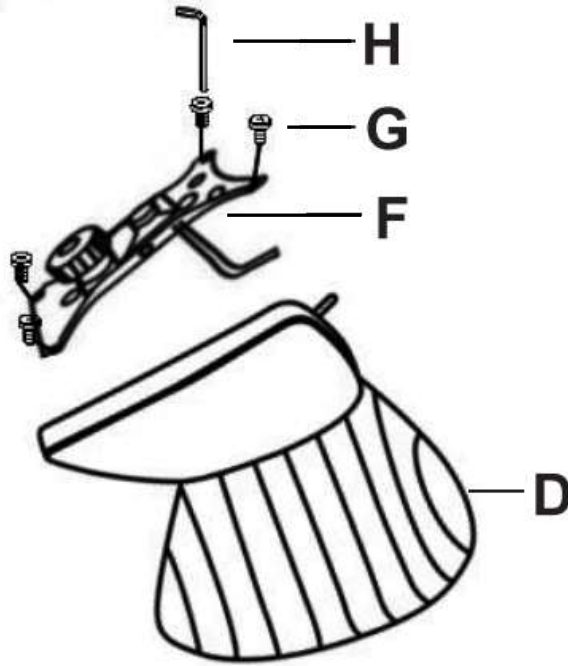

4 Attach Seat (D) to the chair base as shown.

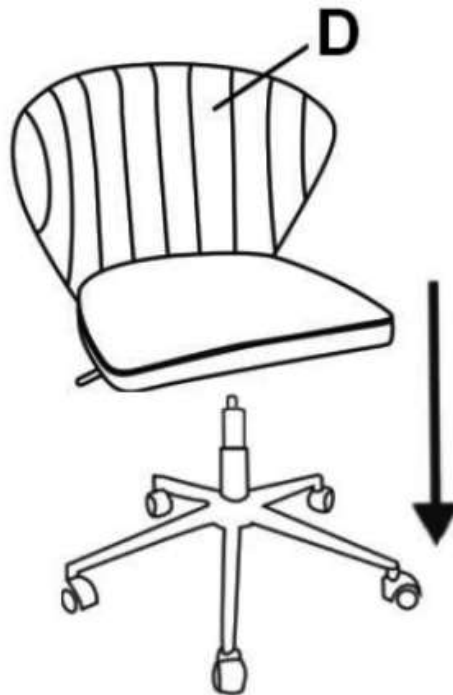

Cleaning & Care

Treat surface with care. Surface is resistant to scratches but is not scratch resistant. Clean surfaces with a dry or damp soft cloth. Do not use abrasive cleaners. Hardware may loosen over time. Periodically check that all connections are tight.