

Assembly Instructions

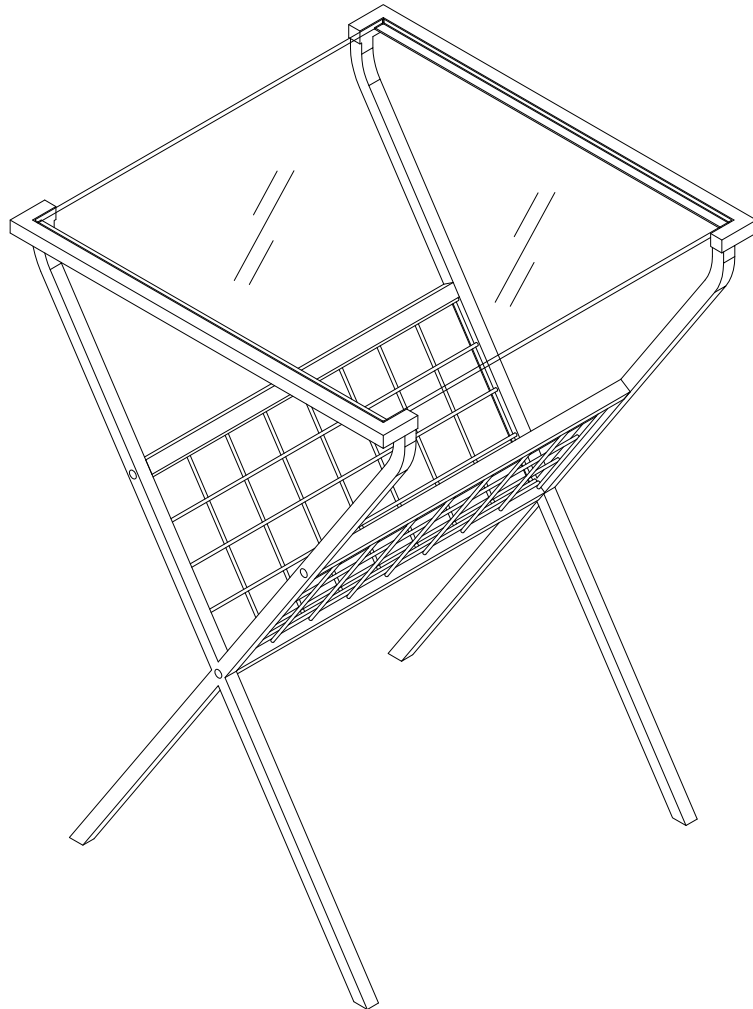

Please visit our website for the most current instructions, assembly tips, report damage, or request parts.

General Assembly Guidelines

- I. Ensure that all parts and hardware are available before beginning assembly.
- II. Follow each step carefully to ensure the proper assembly of this product.
- III. Two people are recommended for ease in the assembly of this product.
- IV. The main type of hardware used to assemble this product are: bolts and screws.
- V. Power tools should not be used to assemble this product.

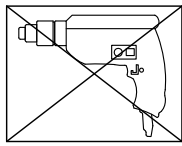

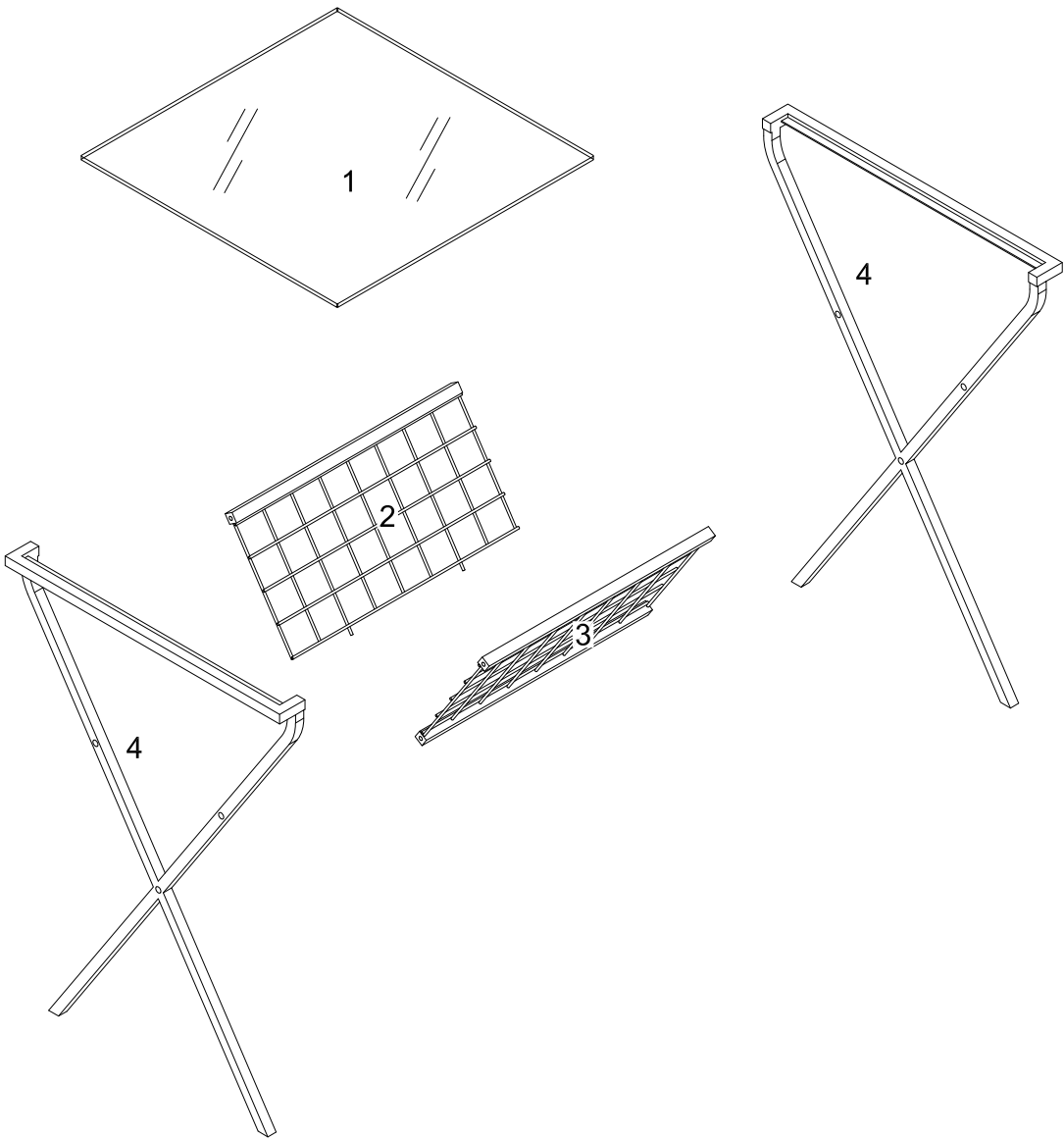

- VI. Drill may be needed for securing product to wall.

Parts List



Hardware List

A		M6*25mm	Bolt	6 pcs
B		25x10x1mm	Glass pads	4 pcs
C		M4	Hex key	1 pc

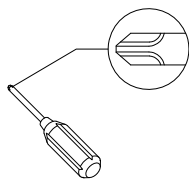

Philips head screwdriver required for assembly
(not included)

*The hardware quantities listed above are required for proper assembly.
Some extra hardware may also have been included.*

Step 1

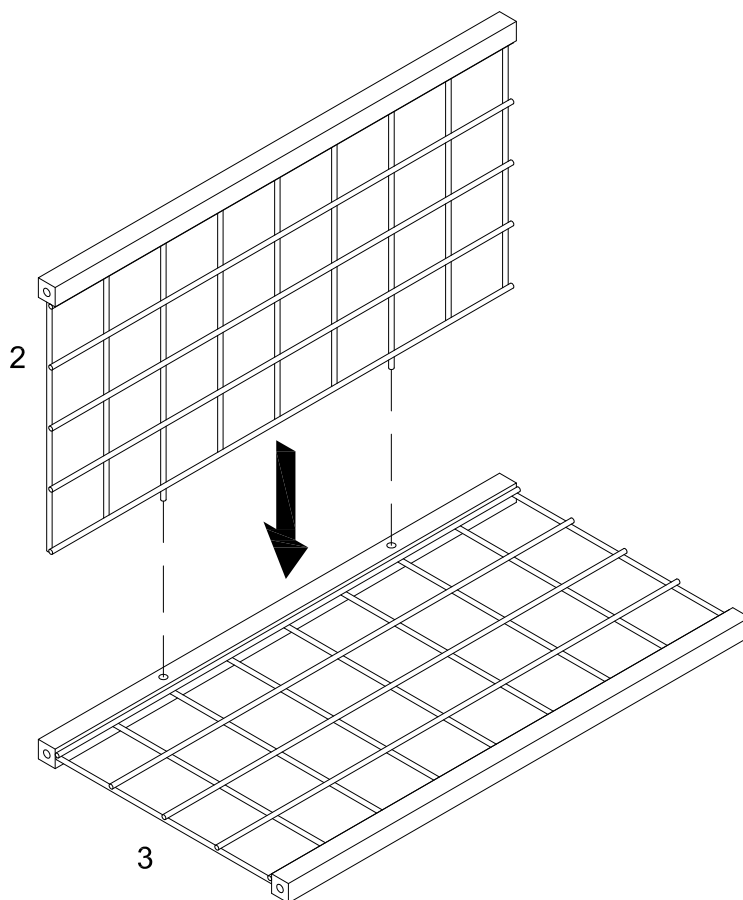

Put part (2) into part (3) as per diagram.

Step 2

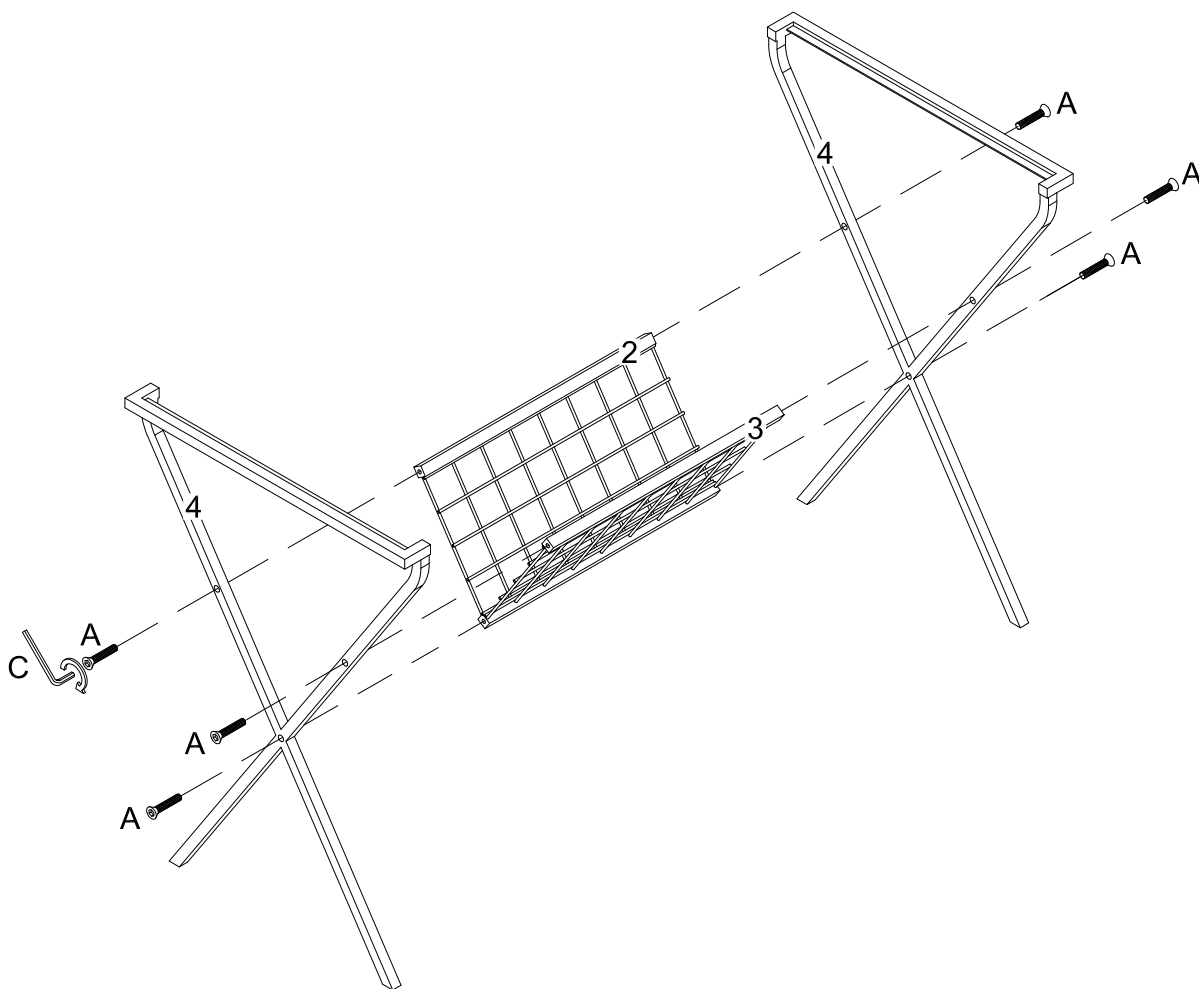

Using bolts (A) into part (4) to parts (2,3) with hex key (C) as per diagram.

Step 3

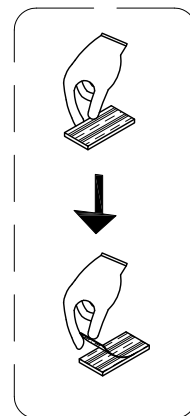
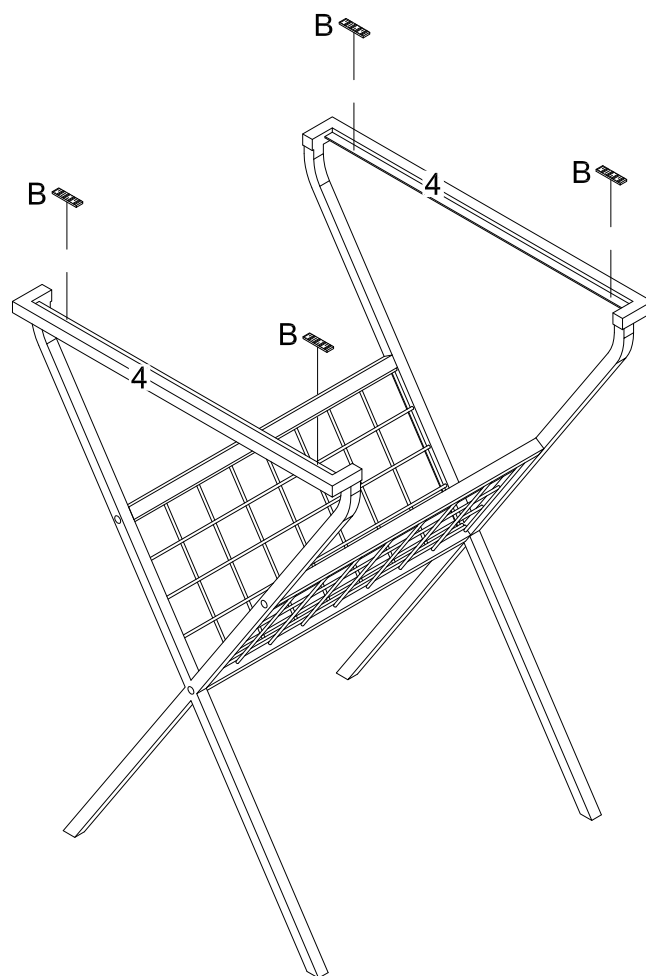

Put glass pads (B) into part (4) as per diagram.

Step 4

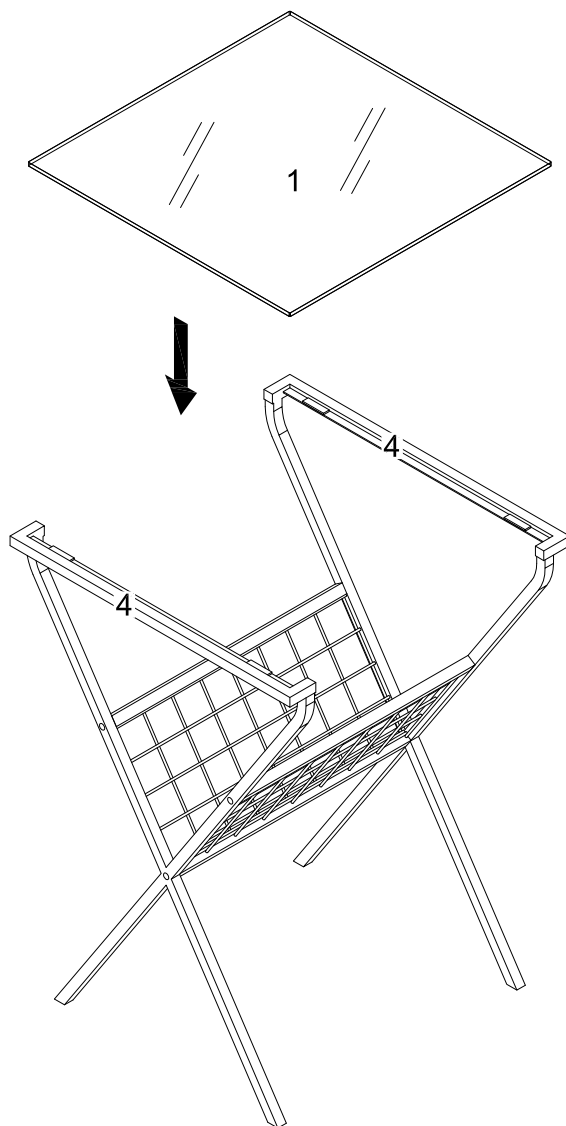

Put part (1) into part (4) as per diagram.

Step 5

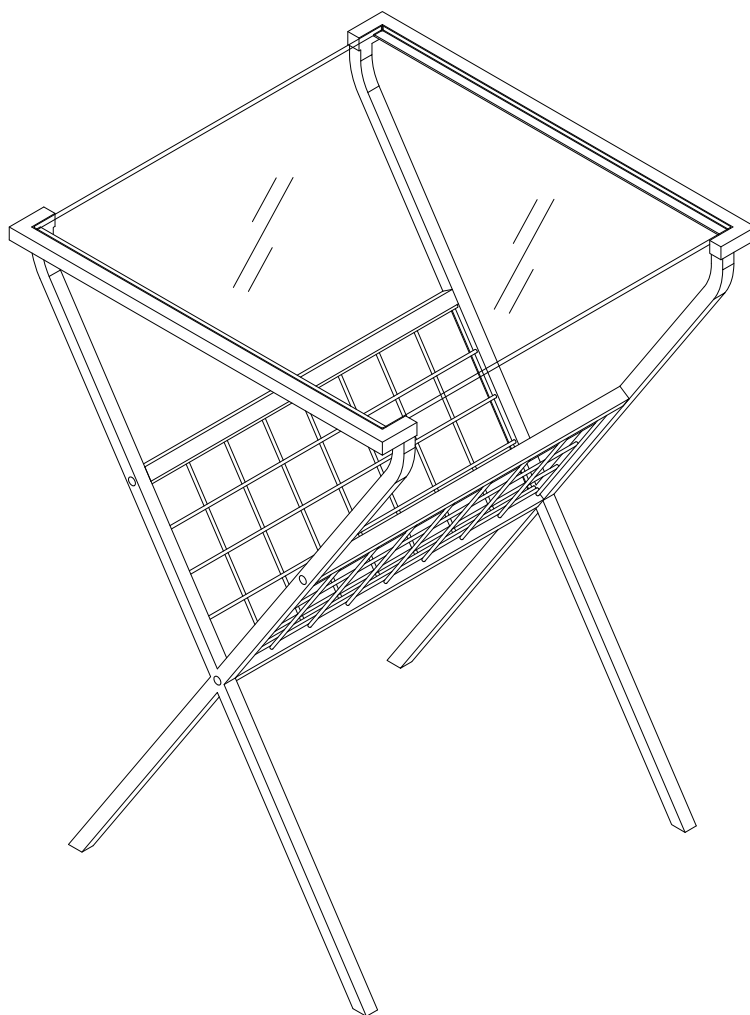

Final Assembly