

# ASSEMBLY INSTRUCTIONS



*Fine Furniture for every stage of life*

## Queen Bed

REVISION 0 : 07/04/2011  
REVISION 1 : 09/27/2011  
REVISION 2 : 07/16/2012  
REVISION 3 : 03/03/2016  
REVISION 4 : 08/27/2018  
REVISION 5 : 10/17/2019  
REVISION 6 : 07/22/2020  
REVISION 7 : 10/18/2024

# ASSEMBLY INSTRUCTIONS

## ASSEMBLY TIPS:

1. Remove hardware from box and sort by size.
2. Please check to see that all hardware and parts are present prior to start of assembly.
3. Please follow attached instructions in the same sequence as numbered to assure fast & easy assembly.



### WARNING!

1. Don't attempt to repair or modify parts that are broken or defective. Please contact the store immediately.
2. This product is for home use only and not intended for commercial establishments.

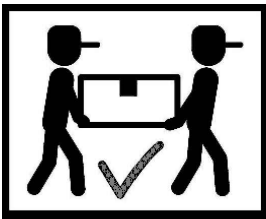

ASSEMBLY TIME

35 MINUTES

## PARTS IDENTIFICATION

### B1 ( BOX 1 )

A HEADBOARD PANEL



1PC

D1 LEFT HEADBOARD LEG



1PC

D2 RIGHT HEADBOARD LEG



1PC

### B2 ( BOX 2 )

C FOOTBOARD

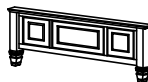

1PC

### B3 ( BOX 3 )

B1 LEFT BED RAIL



1PC

B2 RIGHT BED RAIL



1PC

E BED SLAT

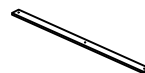

4PCS

F BED SLAT SUPPORT WITH LEVELER



4PCS

HB (B1)  
FROM BOX 1  
HEADBOARD COMPLETE

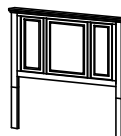

1PC

C (B2)  
FROM BOX 2  
FOOTBOARD

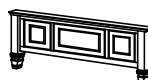

1PC

# ASSEMBLY INSTRUCTIONS

## ASSEMBLY TIPS:

1. Remove hardware from box and sort by size.
2. Please check to see that all hardware and parts are present prior to start of assembly.
3. Please follow attached instructions in the same sequence as numbered to assure fast & easy assembly.



## WARNING!

1. Don't attempt to repair or modify parts that are broken or defective. Please contact the store immediately.
2. This product is for home use only and not intended for commercial establishments.

## HARDWARE IDENTIFICATION

### Z-B3 (BOX 3) - HARDWARE PACK IS LOCATED

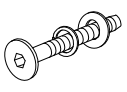
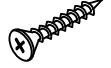
1	<b>ALLEN WRENCH</b> (M4 - BLK)		1PC
2	<b>BOLT</b> (M6 x 50mm - BLK)		8PCS
3	<b>FLAT HEAD SCREW</b> (M4 x 32mm - BLK)		8PCS

## NOTE:

Phillips head screw driver is required in the assembly process; however, manufacturer does not provide this item.

# ASSEMBLY INSTRUCTIONS

## STEP 1

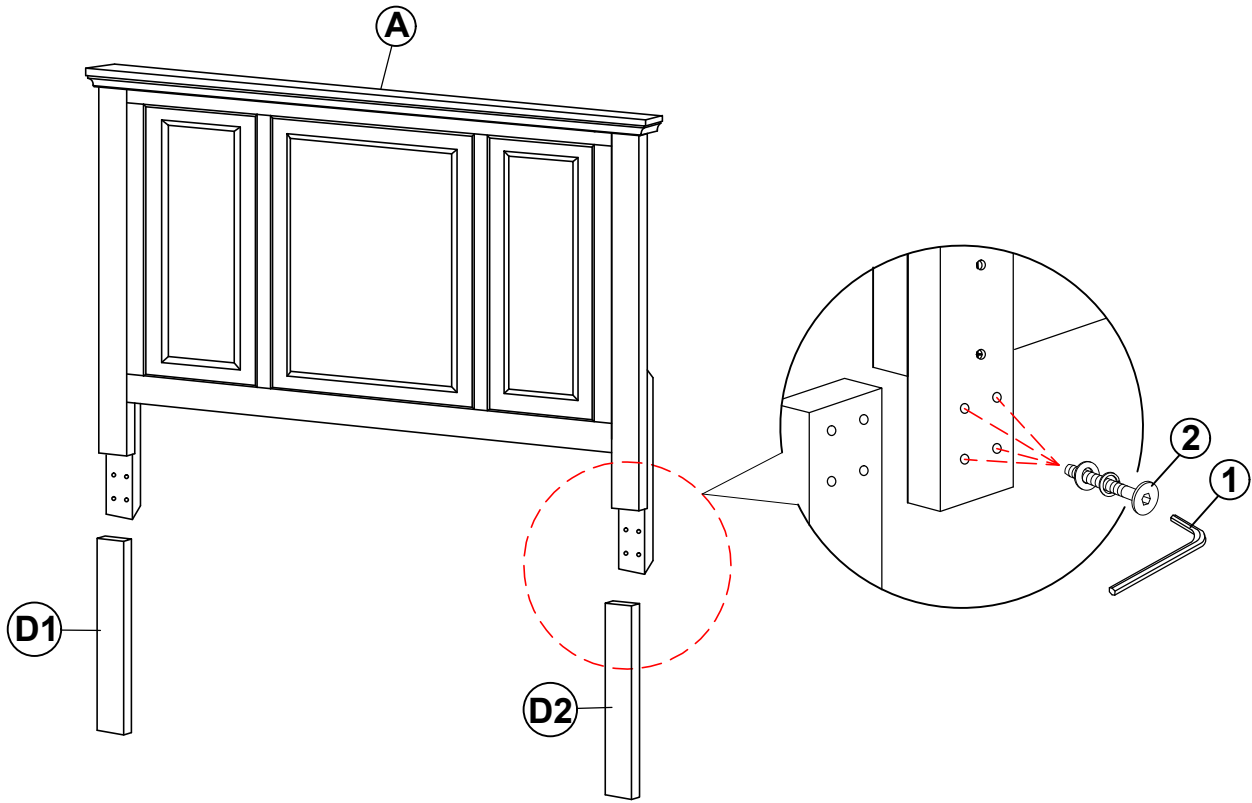

## STEP 2

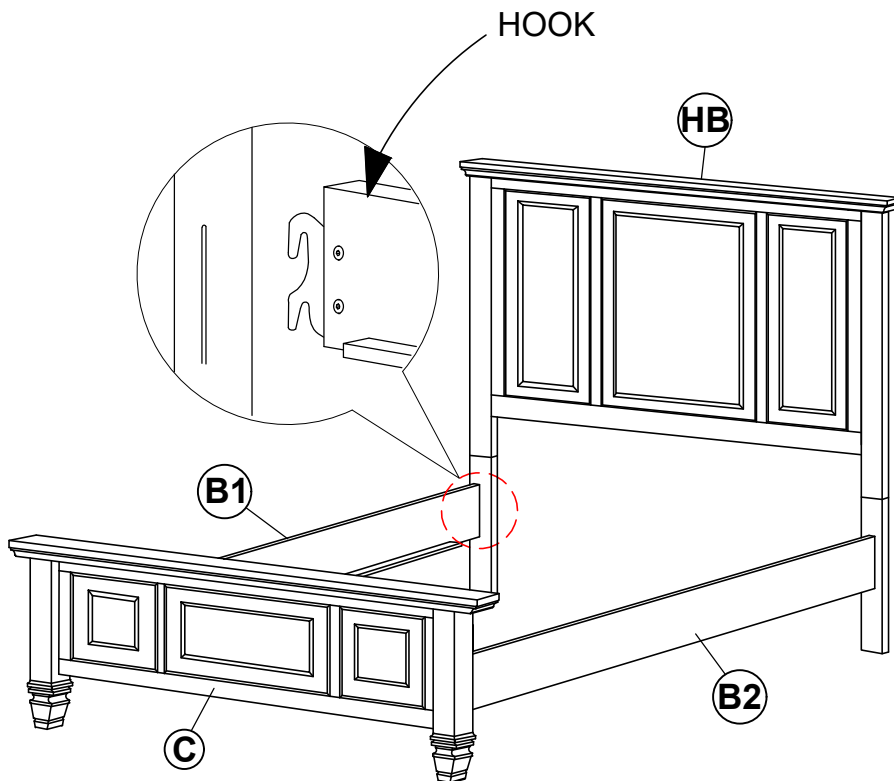

# ASSEMBLY INSTRUCTIONS

## STEP 3

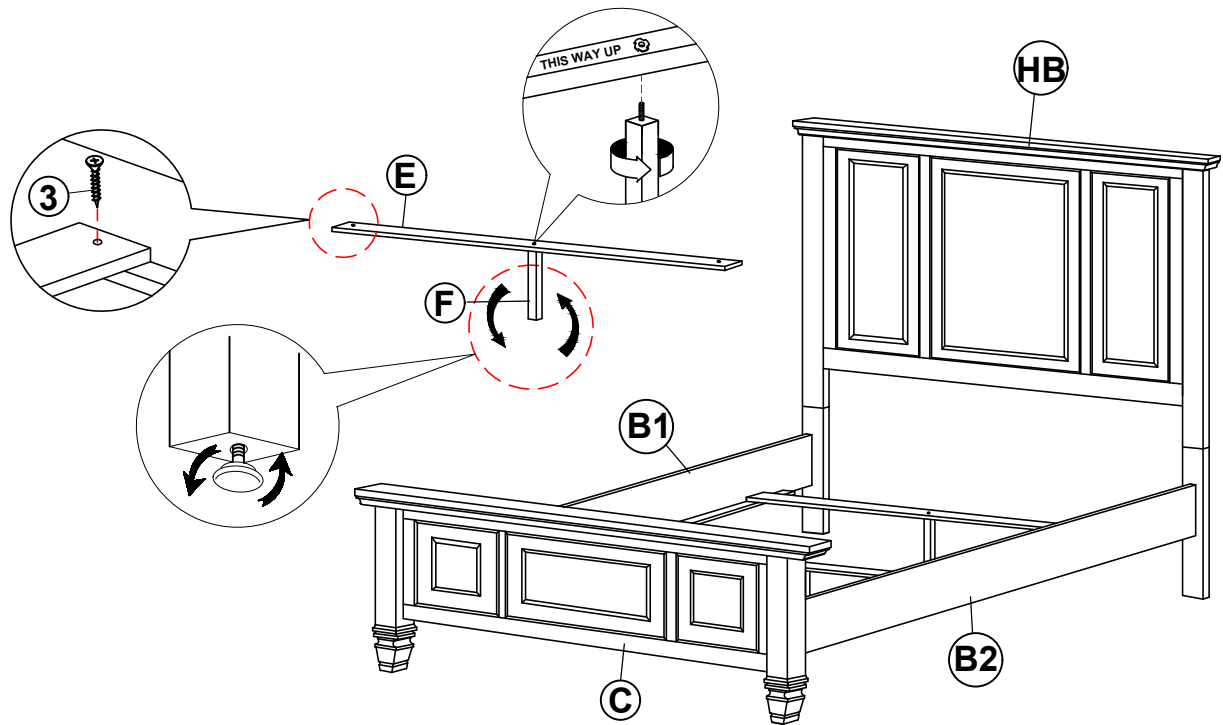

## STEP 4 COMPLETE

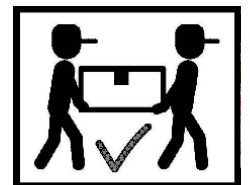
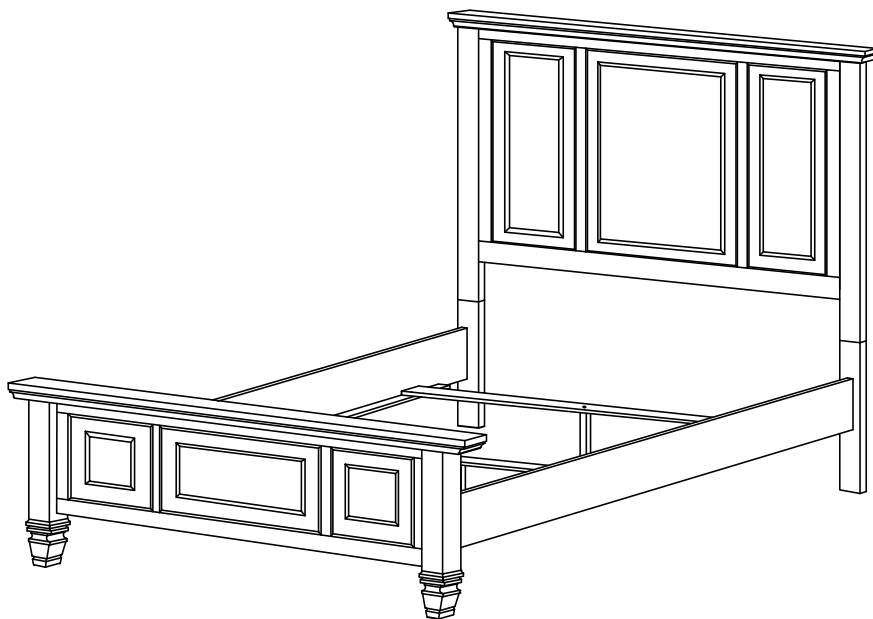

Inner Size : 61.00"W x 81.00"D

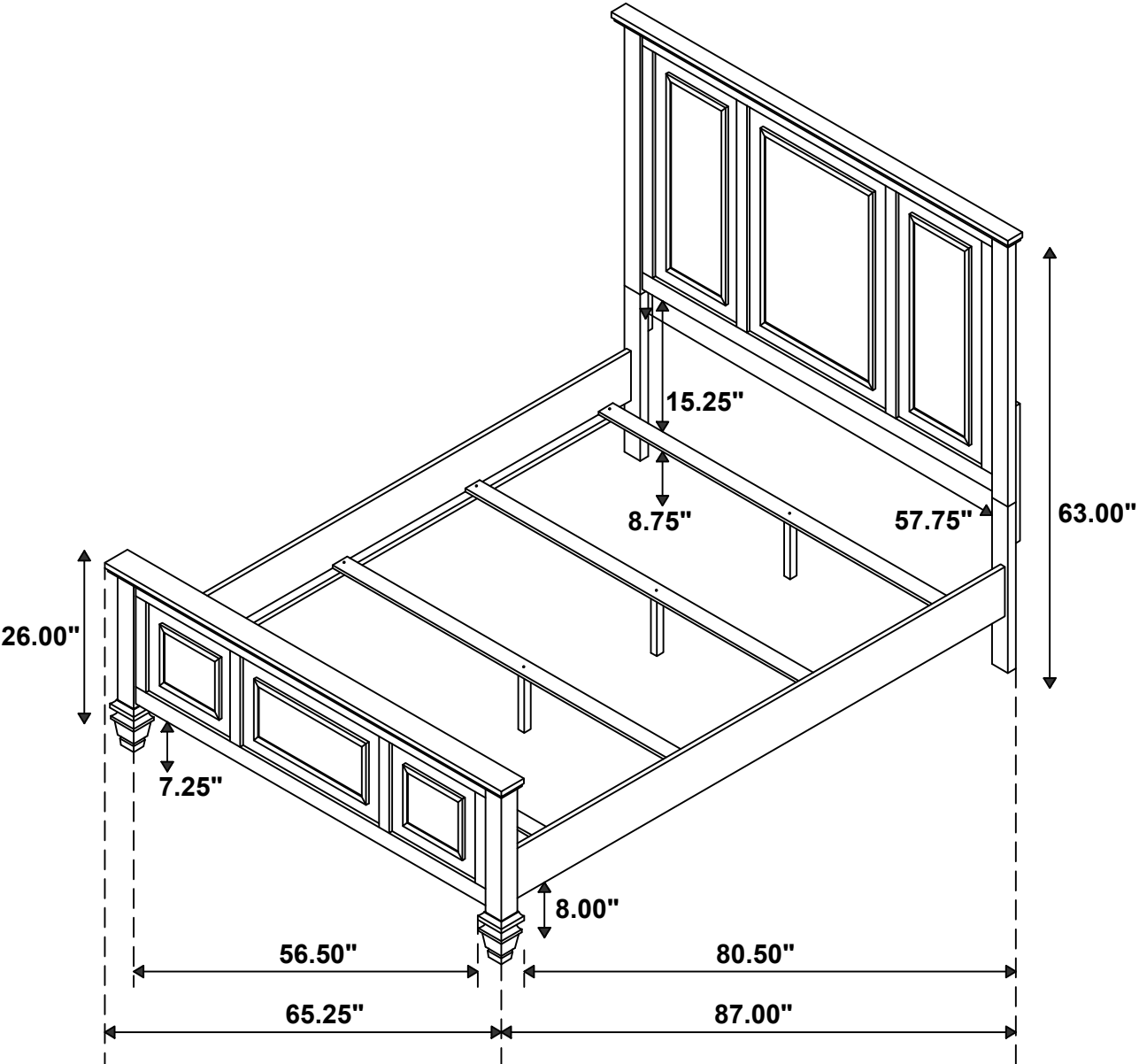

Note : Dimension tolerance  $\pm 5\%$

# ASSEMBLY INSTRUCTIONS



*Fine Furniture for every stage of life*

## *Nightstand*

REVISION 0 : 04/10/2009  
REVISION 1 : 01/30/2013  
REVISION 2 : 02/23/2017  
REVISION 3 : 08/27/2018  
REVISION 4 : 10/17/2019

PAGE 1 OF 4

# ASSEMBLY INSTRUCTIONS

## ASSEMBLY TIPS:

1. Remove hardware from box and sort by size.
2. Please check to see that all hardware and parts are present prior to start of assembly.
3. Please follow attached instructions in the same sequence as numbered to assure fast & easy assembly.



### WARNING!

1. Don't attempt to repair or modify parts that are broken or defective. Please contact the store immediately.
2. This product is for home use only and not intended for commercial establishments.

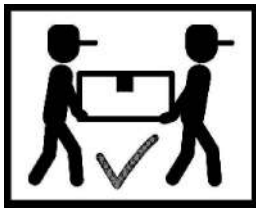

ASSEMBLY TIME

10 MINUTES

## PARTS IDENTIFICATION

A NIGHTSTAND



1PC

### NOTE:

Phillips head screw driver is required in the assembly process; however, manufacturer does not provide this item.

# ASSEMBLY INSTRUCTIONS

## STEP 1

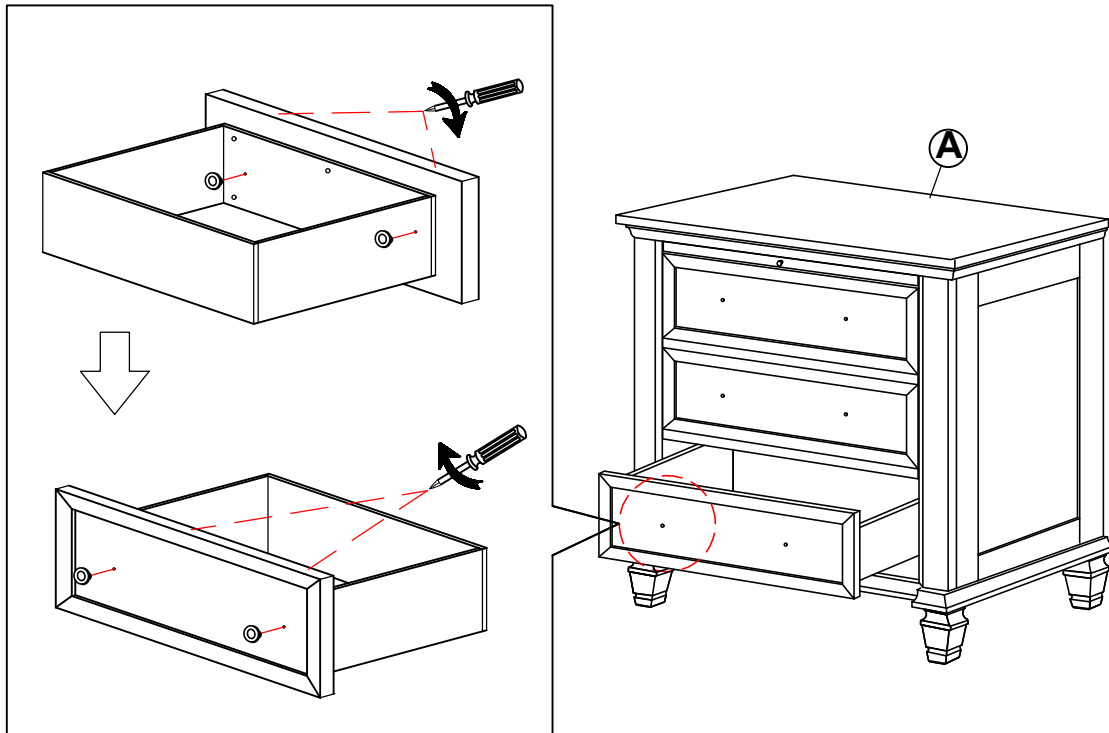

## STEP 2

### COMPLETE

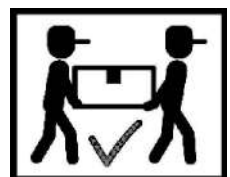

# ANTI-TIPPING INSTALLMENT INSTRUCTIONS

## FURNITURE TIPPING RESTRAINT

### WARNING

Injury may result from tipping furniture.  
This restraint may protect against tipping furniture.  
Do not allow children to climb on furniture.  
This restraint is not a substitute for proper adult supervision.  
Failure to detach this restraint before moving the furniture may result in injury and damage.

This tip restraint must be attached to a wall stud using long screw enclosed.

### STEP 1

Attach a bracket securely to the back top rail of the furniture using short screw provided, through the smaller hole.

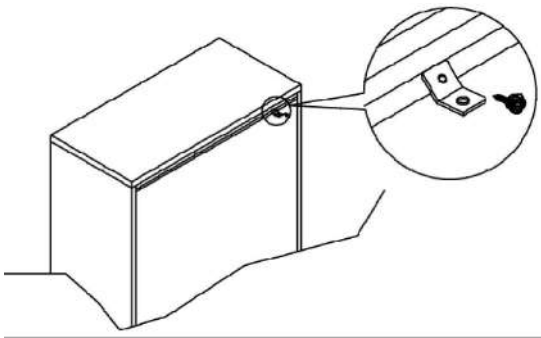

### STEP 2

Locate the other bracket on the wall over a wall stud and two inches below the mounting bracket secured to the back of furniture. Attach the wall stud using the long screw provided, through the smaller hole.

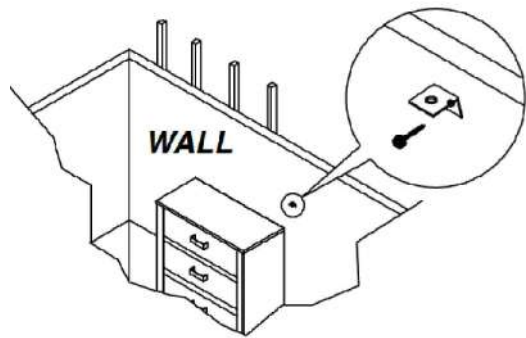

### STEP 3

Place the furniture into position so both mounting brackets are vertically in line. Lace the end of the restraint strap through the large hole in each mounting bracket. Bring both ends together and slide the flat end through the locking end and draw it through until all slack is removed. Confirm that the strap is securely laced and locked.

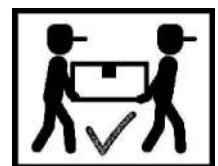
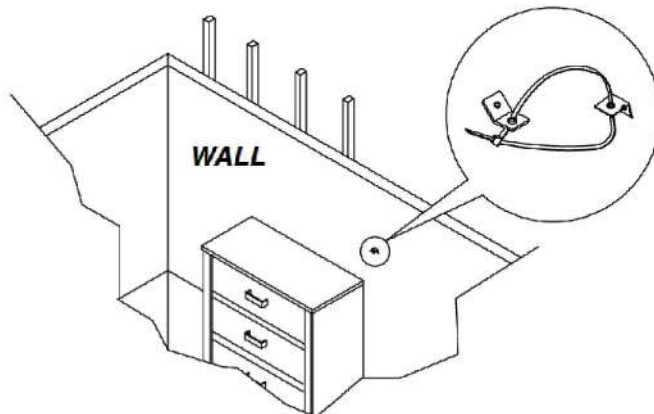

**Inner Size of Drawer A : 19.50"W X 12.75"D X 2.75"H X 0.50"T**  
**Inner Size of Drawer B : 19.50"W X 12.75"D X 4.00"H X 0.50"T**

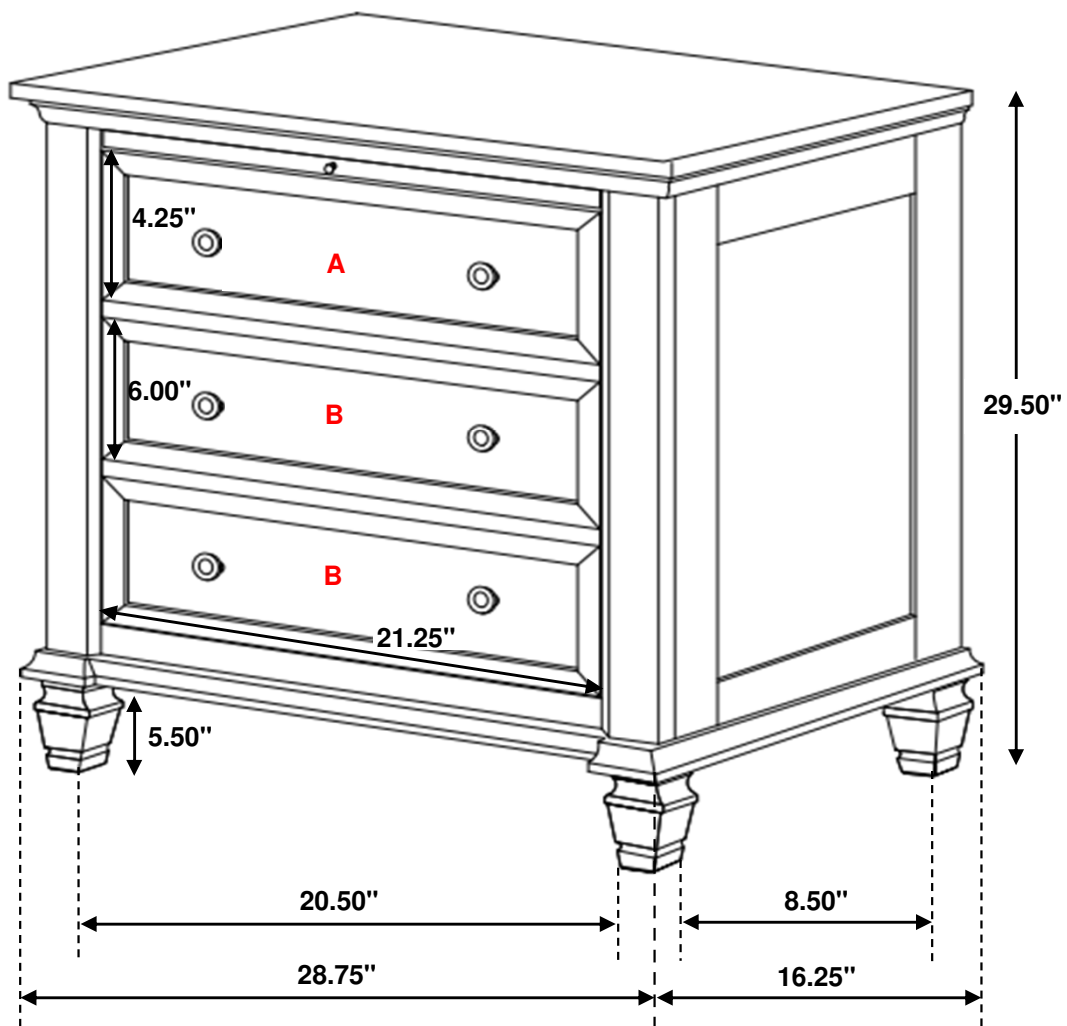

**Note : Dimension tolerance  $\pm 5\%$**

# ASSEMBLY INSTRUCTIONS



*Fine Furniture for every stage of life*

***Dresser***

REVISION 0 : 04/10/2009  
REVISION 1 : 01/30/2013  
REVISION 2 : 08/27/2018  
REVISION 3 : 10/17/2019  
REVISION 4 : 07/05/2024

# ASSEMBLY INSTRUCTIONS

## ASSEMBLY TIPS:

1. Remove hardware from box and sort by size.
2. Please check to see that all hardware and parts are present prior to start of assembly.
3. Please follow attached instructions in the same sequence as numbered to assure fast & easy assembly.



### WARNING!

1. Don't attempt to repair or modify parts that are broken or defective. Please contact the store immediately.
2. This product is for home use only and not intended for commercial establishments.

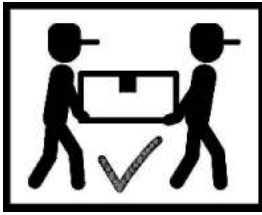

ASSEMBLY TIME

10 MINUTES

## PARTS IDENTIFICATION

A DRESSER

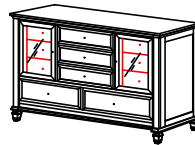

1PC

### NOTE:

Phillips head screw driver is required in the assembly process; however, manufacturer does not provide this item.

# ASSEMBLY INSTRUCTIONS

## STEP 1

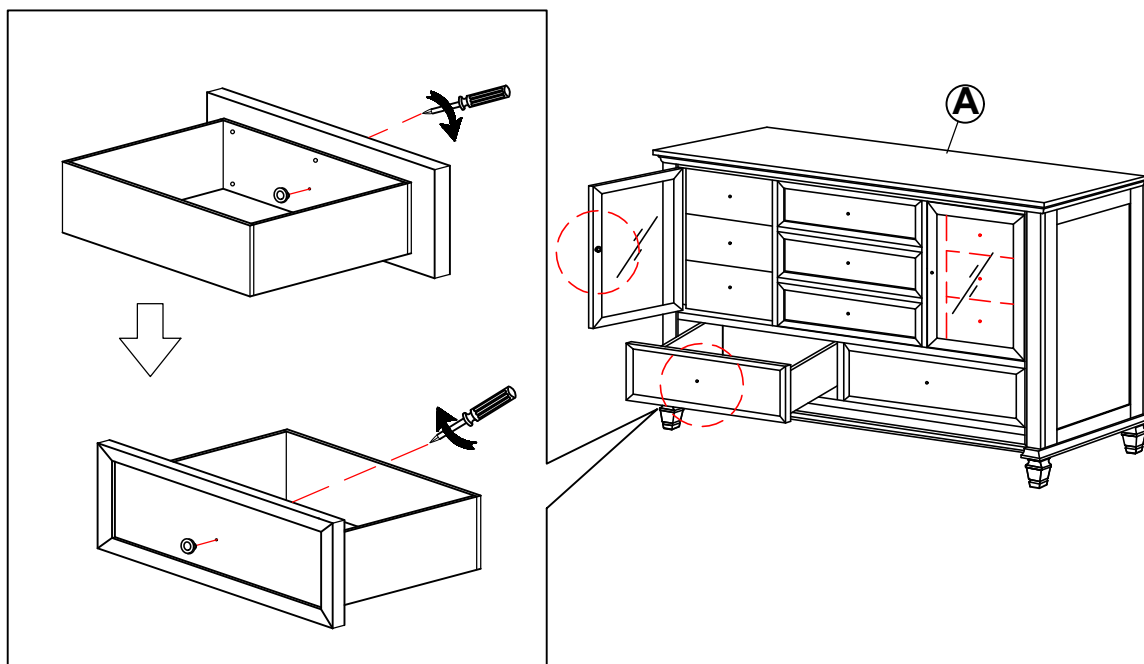

# ASSEMBLY INSTRUCTIONS

## STEP 2

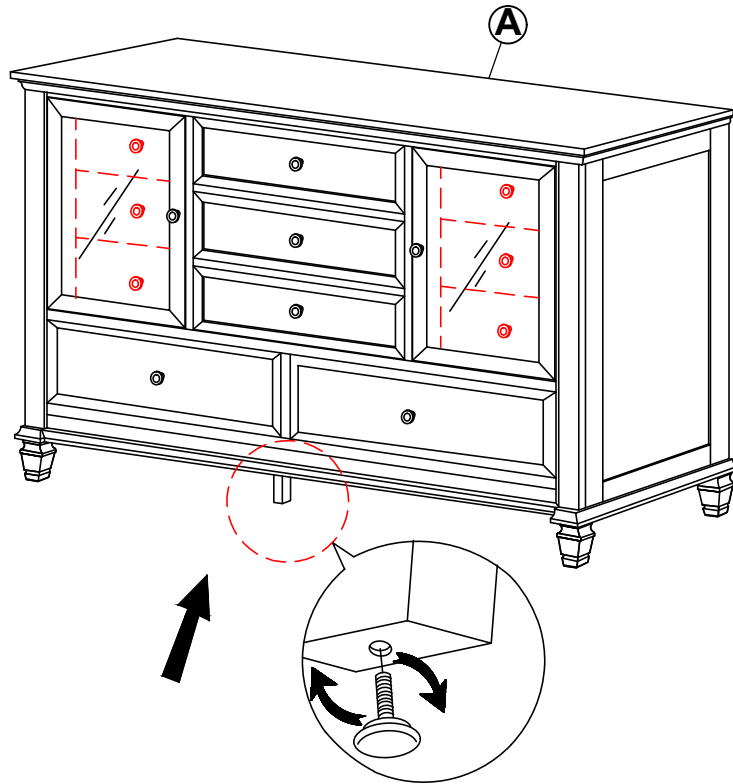

## STEP 3 **COMPLETE**

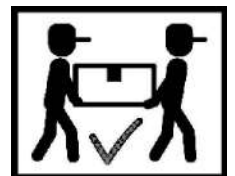
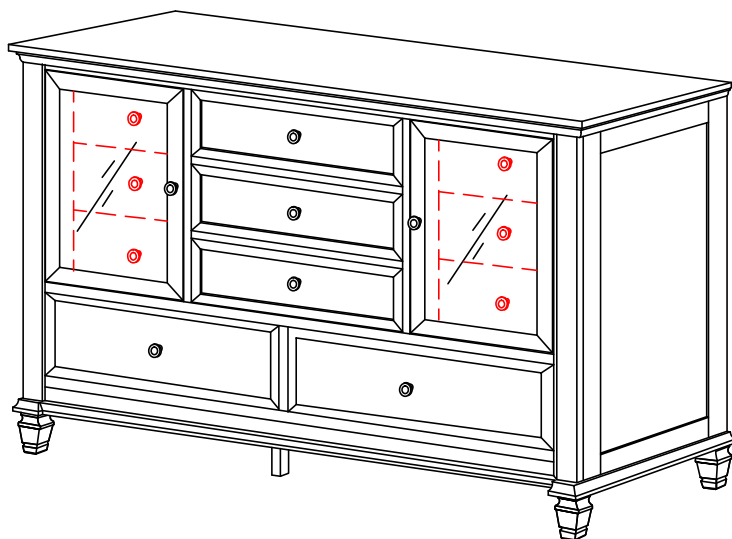

# ANTI-TIPPING INSTALLMENT INSTRUCTIONS

## FURNITURE TIPPING RESTRAINT

### WARNING

Injury may result from tipping furniture.  
This restraint may protect against tipping furniture.  
Do not allow children to climb on furniture.  
This restraint is not a substitute for proper adult supervision.  
Failure to detach this restraint before moving the furniture may result in injury and damage.

1. Attach one of the mounting brackets securely to the back edge of the unit, using the short screw.
2. Determine where the unit is to be placed, and mark the location on the wall for the other mounting bracket. The bracket on the wall needs to be approximately 2" below the bracket mounted to the edge of the unit.
3. Drill a hole in the wall. Insert the plastic wall anchor into the hole and if necessary, use a small block of wood and hammer to tap it in so that it's flush with the wall.
4. Attach the bracket over the plastic wall anchor using the long screw.
5. Place the unit against the wall, both brackets need to be facing each other.
6. Lace an end of the restraint strap through the hole in each bracket. Bring both ends together and rotate the thumb nut onto the threaded end until tight.
7. Ensure that the restraint strap is securely laced and locked.

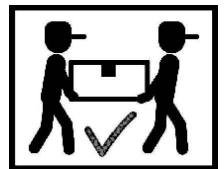
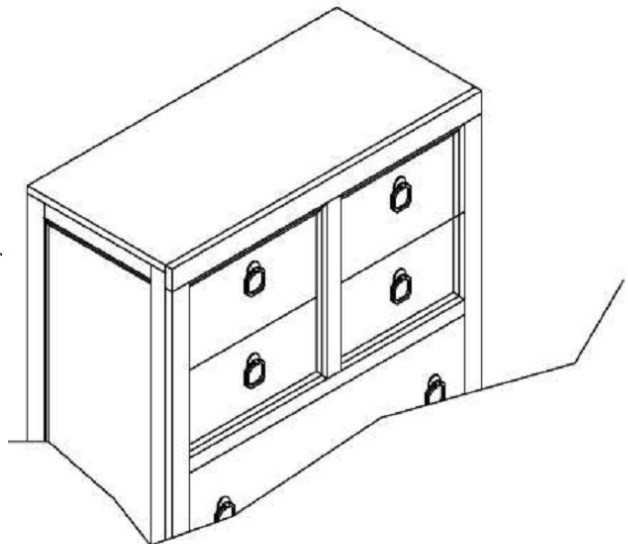
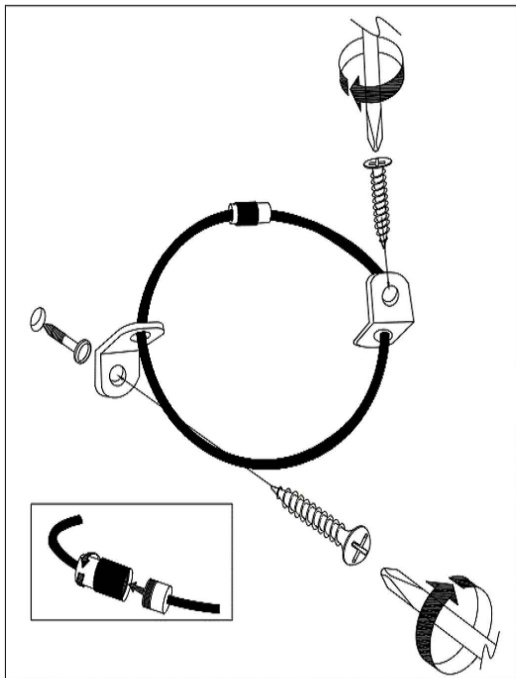

**Inner Size of Drawer A : 10.25"W x 10.75"D x 4.00"H x 0.50"T**  
**Inner Size of Drawer B : 19.50"W x 12.75"D x 4.00"H x 0.50"T**  
**Inner Size of Drawer C : 24.50"W x 12.75"D x 5.50"H x 0.50"T**

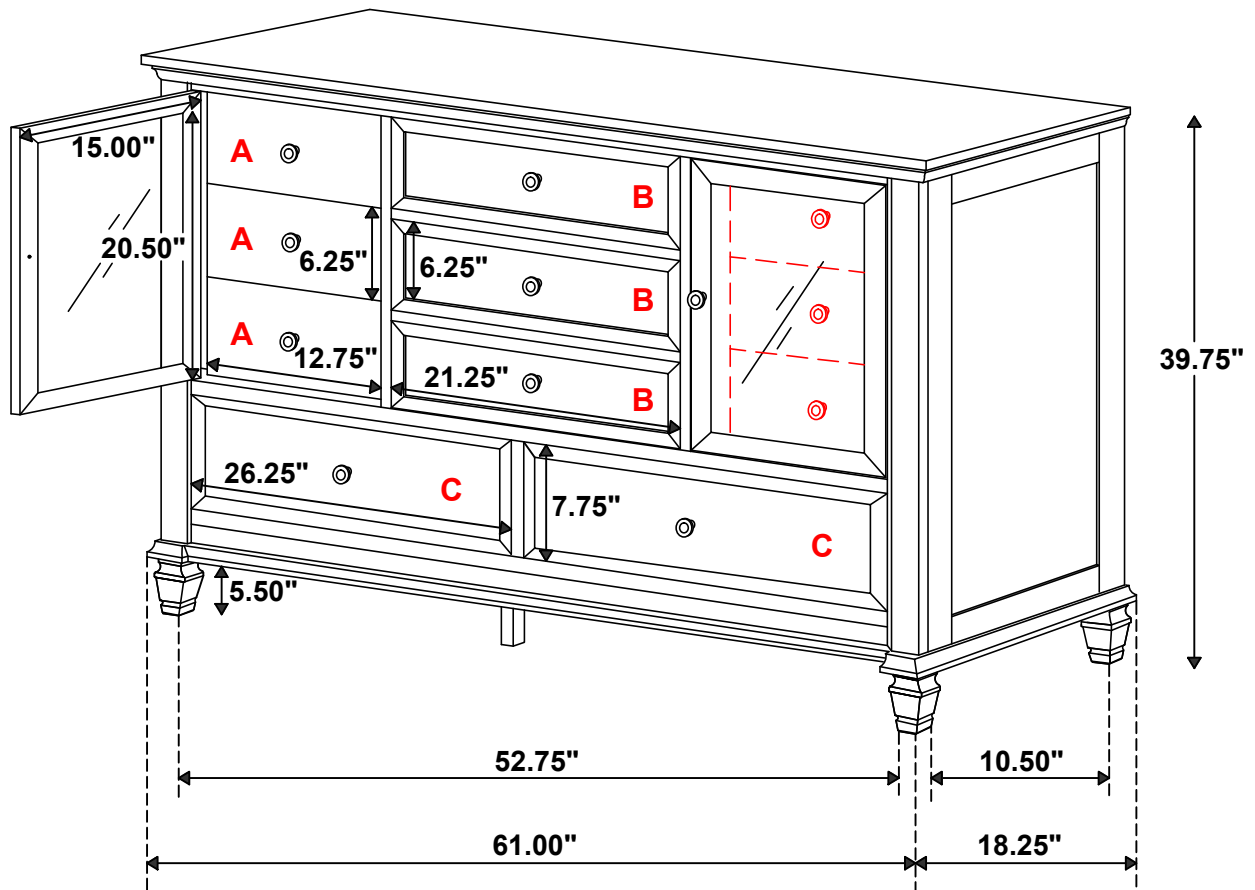

**Note : Dimension tolerance ±5%**

# ASSEMBLY INSTRUCTIONS



*Fine Furniture for every stage of life*

REVISION 0 : 04/10/2009  
REVISION 1 : 01/30/2013  
REVISION 2 : 08/27/2018  
REVISION 3 : 10/17/2019  
REVISION 4 : 08/04/2020  
REVISION 5 : 09/04/2023

# ASSEMBLY INSTRUCTIONS

## ASSEMBLY TIPS:

1. Remove hardware from box and sort by size.
2. Please check to see that all hardware and parts are present prior to start of assembly.
3. Please follow attached instructions in the same sequence as numbered to assure fast & easy assembly.



### WARNING!

1. Don't attempt to repair or modify parts that are broken or defective. Please contact the store immediately.
2. This product is for home use only and not intended for commercial establishments.

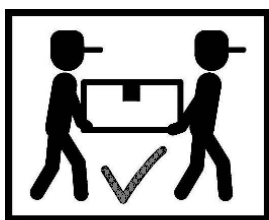

ASSEMBLY TIME

10 MINUTES

## PARTS IDENTIFICATION

A MIRROR

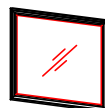

1PC

B DRESSER  
\*FROM BOX

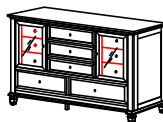

1PC

C MIRROR SUPPORT  
(PACKED WITH DRESSER)

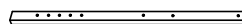

2PCS

## HARDWARE IDENTIFICATION

1 SHORT FLAT HEAD SCREW  
(M4 x 32mm - BLK)



4PCS

2 LONG FLAT HEAD SCREW  
(M4 x 45mm - BLK)



4PCS

### NOTE:

Phillips head screw driver is required in the assembly process; however, manufacturer does not provide this item.

# ASSEMBLY INSTRUCTIONS

## STEP 1

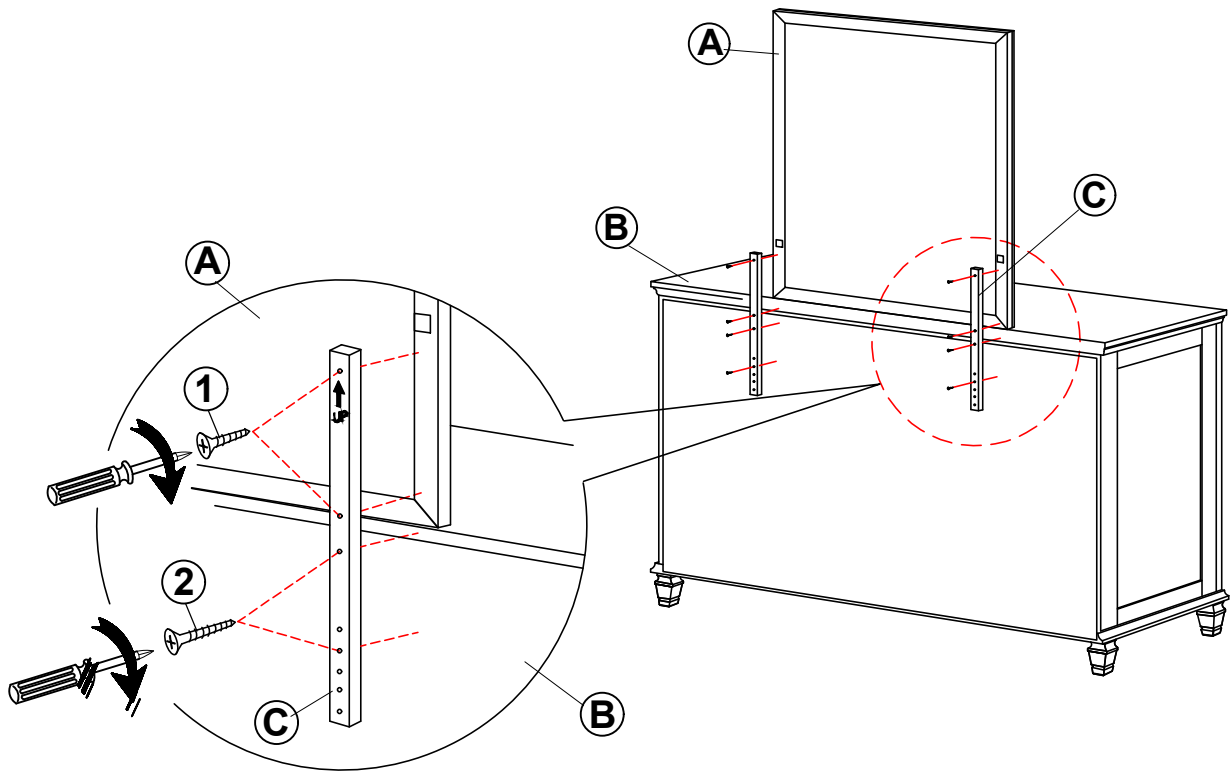

## STEP 2

### COMPLETE

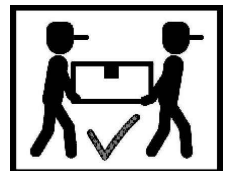
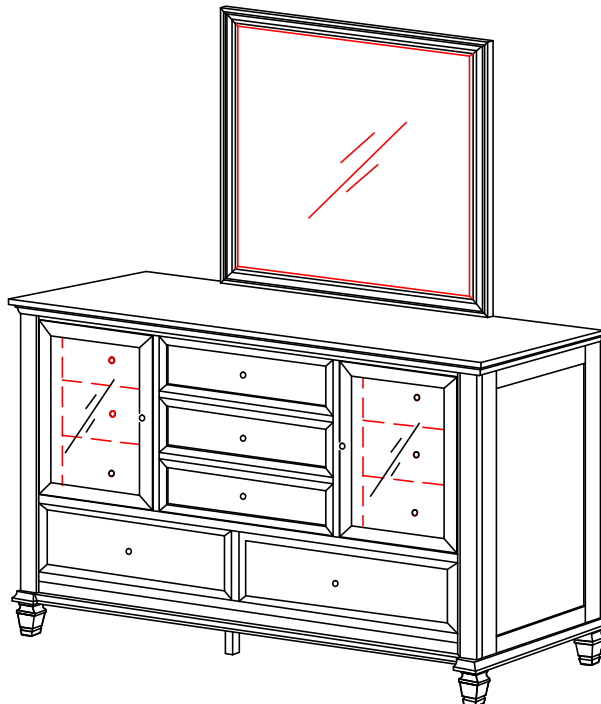

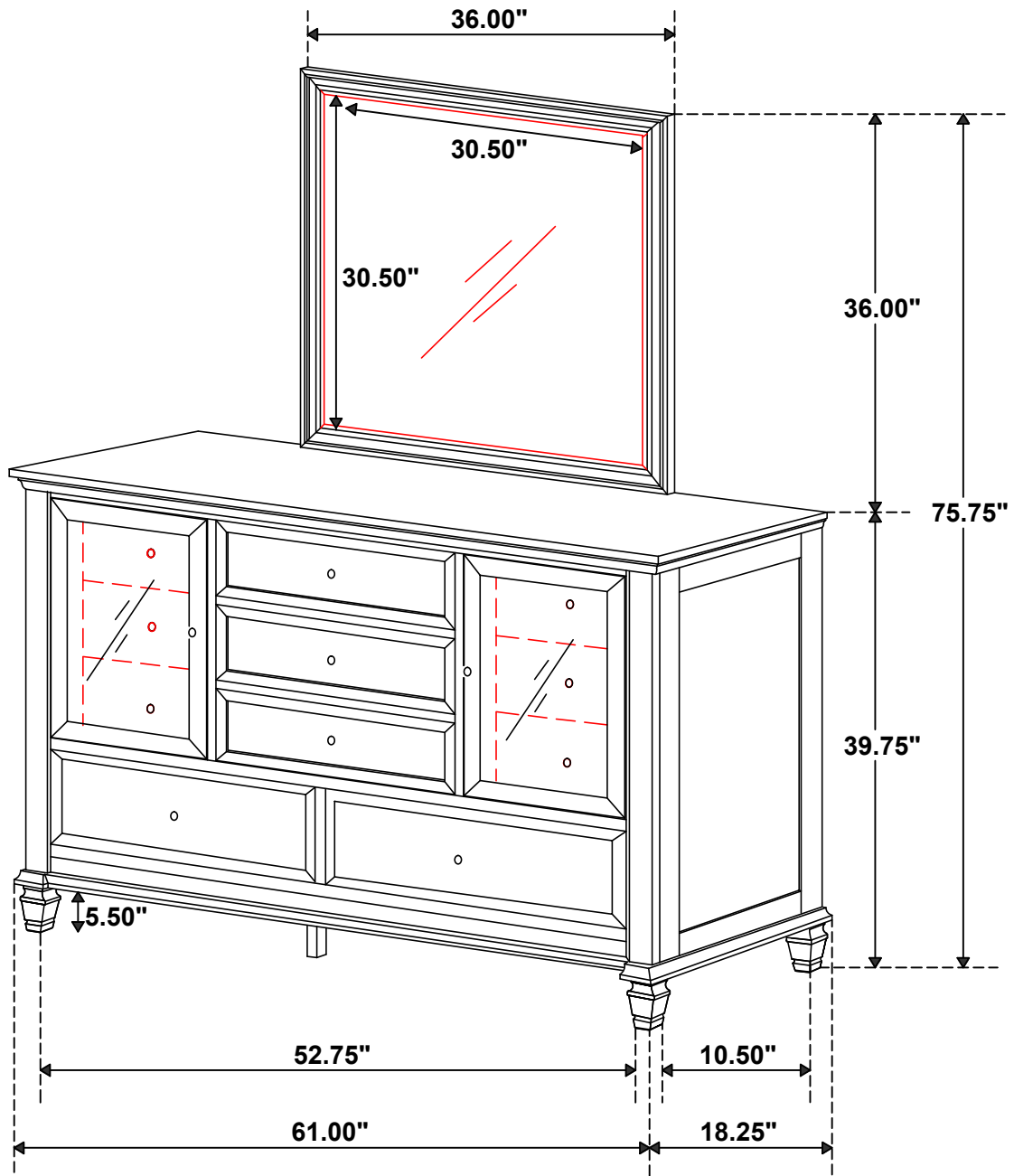

Note : Dimension tolerance  $\pm 5\%$