

6-Drawer Dresser Assembly Instructions

DATE STAMP	
------------	--

This product is shipped in
2 cartons

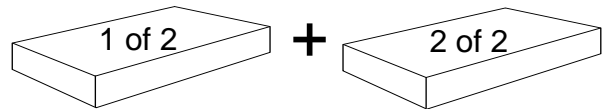

Make sure you have both cartons. Sometimes cartons shipped on the same day get separated and are delivered on different days.

- For help with assembly
- If you have received a damaged or defective part or are missing hardware.

We will process replacement parts in 2 business days or less. Parts are shipped via UPS Ground or mail.

Before you call please:



- 1) Record the following information from the shipping label on the outside of the box. You will need it for warranty purposes:
 - Ship To Name
 - Sales Order Number
- 2) Note the product model number.
- 3) Review the contents of your shipment to determine what you are missing.



Depending on collection, the style of your product may vary from this picture.

Online Option:

Fill out the Replacement Parts Order form in the Product

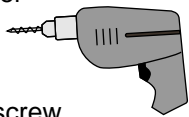
Required Tools	Optional Tools
<p>Screwdrivers</p>   <p>Phillips Head</p> <p>Flat Head</p>  <p>Hammer</p>	<p>Using a power screwdriver will speed up assembly.</p>  <p>Caution Do not over tighten any screw. The last few turns of each screw should be done very slowly or by hand.</p>

Hardware Identification

Cabinet Hardware

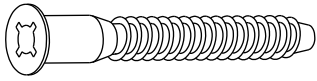

2" Confirmat Screws
(8)



Screw Cover Caps
(8)

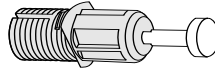

Blue Rapid Rod
(2)



15mm Zinc Cam
(8)

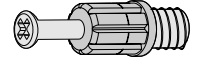

Green Twister Dowel
(6)

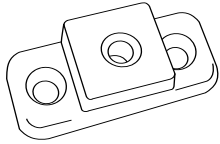

T Spacer
(24)

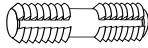

Plastic Dowels
(14)



3/4" Nail
(36)*



Drawer Slide Screw
(72)

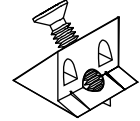

Drawer Bottom Stabilizer
(6)

black
cherry
espresso
maple
white

*More than required

*More than required

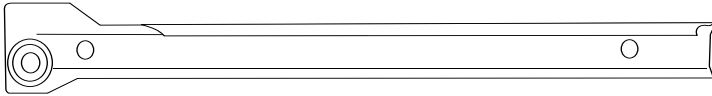

LEFT Cabinet Slide (6)

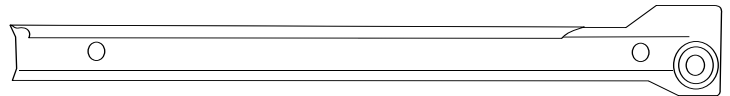

RIGHT Cabinet Slide (6)

Drawer Hardware

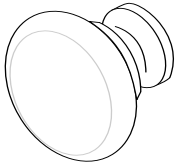

b (12)
maple / black
white / cherry
espresso



#8 7/8" Machine Screw
(12)

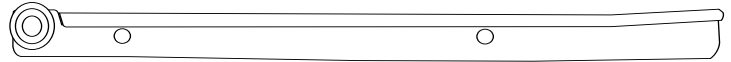

1 LEFT Drawer Slide per Drawer (Total = 6)



1 RIGHT Drawer Slide per Drawer (Total = 6)

Set of Grey Drawer & Cabinet Slides (6 Sets)

4 per drawer



#8 - 1 1/2" Hi Lo Screws
(24)



12mm Zinc Cam
(24)

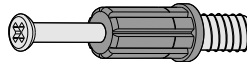

Black Twister Dowel
(24)

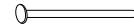

3/4" Nail
(24)



Drawer Slide Screw
(24)

Cable Tie Hardware Package

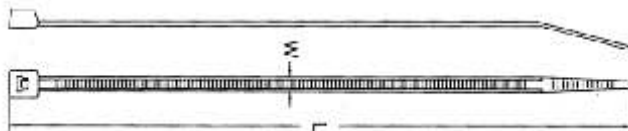

Cable Tie (1)
Attache pour câble



Mounting Base (2)
Base de support

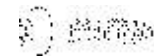

#6-3/4" Pan Head
Screw (1)
Vis #6-3/4 po.

Cabinet Parts

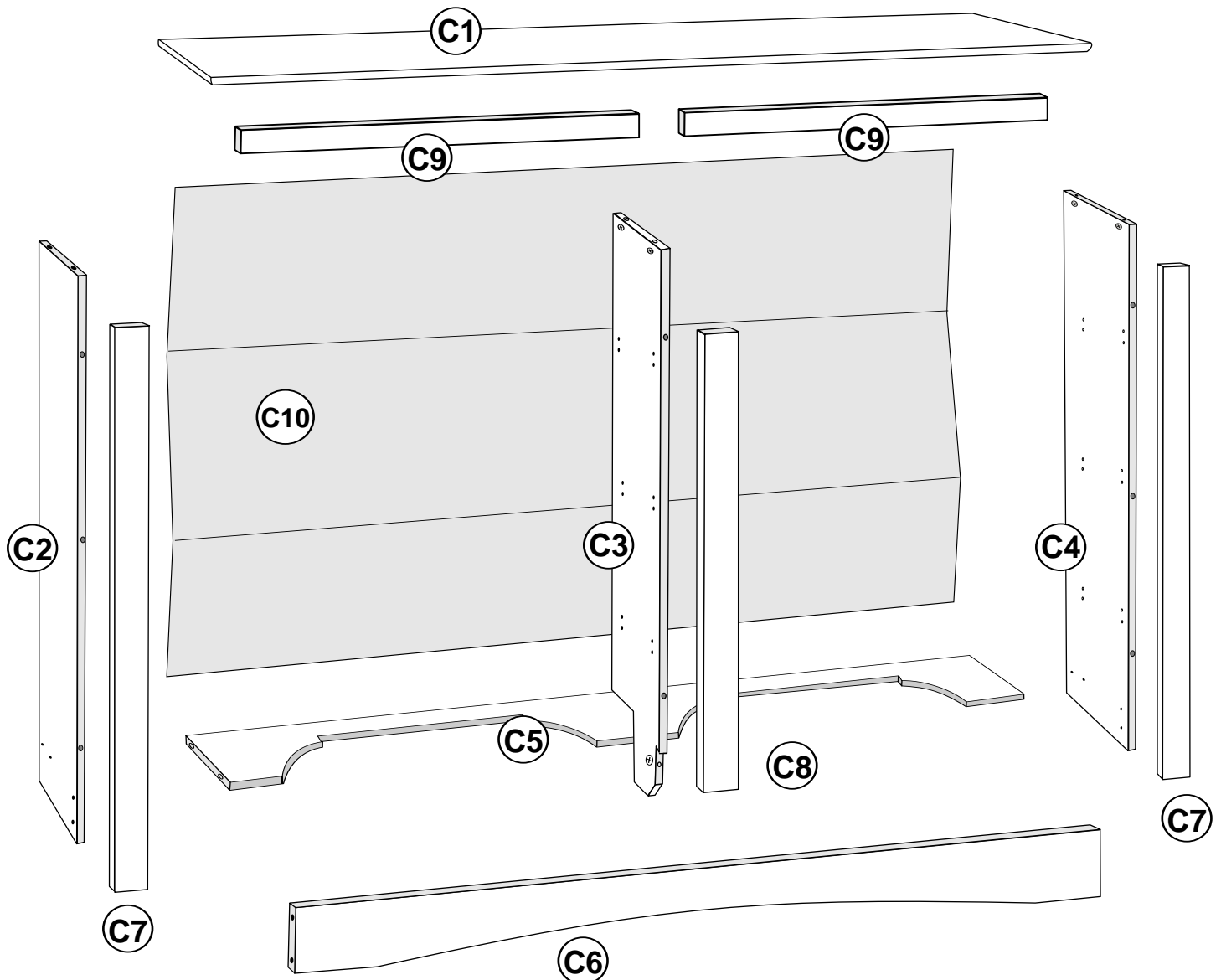

C1

Profiled Top (1)
black
cherry
espresso
maple
white

C2

Left Side (1)
black
cherry
espresso
maple
white

C3

Center Divider (1)
unfinished

C4

Right Side (1)
black
cherry
espresso
maple
white

C5

Decorative Stabilizer A (1)
black
cherry
espresso
maple
white

C6

Decorative Stabilizer B (1)
black
cherry
espresso
maple
white

C7

1¾" Side Molding (2)
black
cherry
espresso
maple
white

C8

1¾" Center Molding (1)
black
cherry
espresso
maple
white

C9

1¾" Top Molding (2)
black
cherry
espresso
maple
white

C10

Folded Backer (1)

STEP 1 Estimated Time: 15 - 25 minutes

1a Attach T-spacers to left and right sides and to both sides of the center divider using drawer slide screws

1b Then, attach metal cabinet slides to T-spacers using drawer slide screws

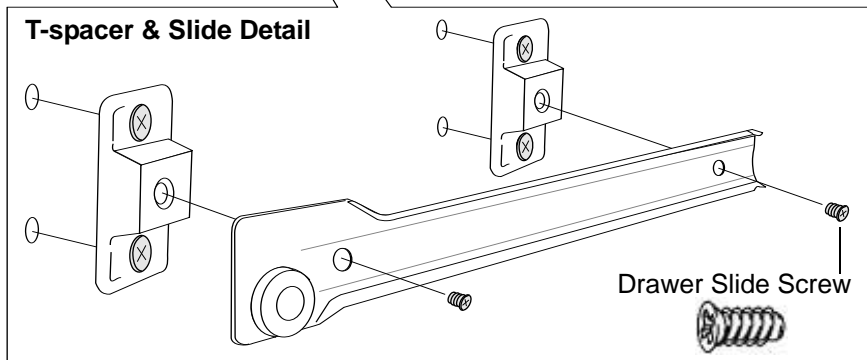
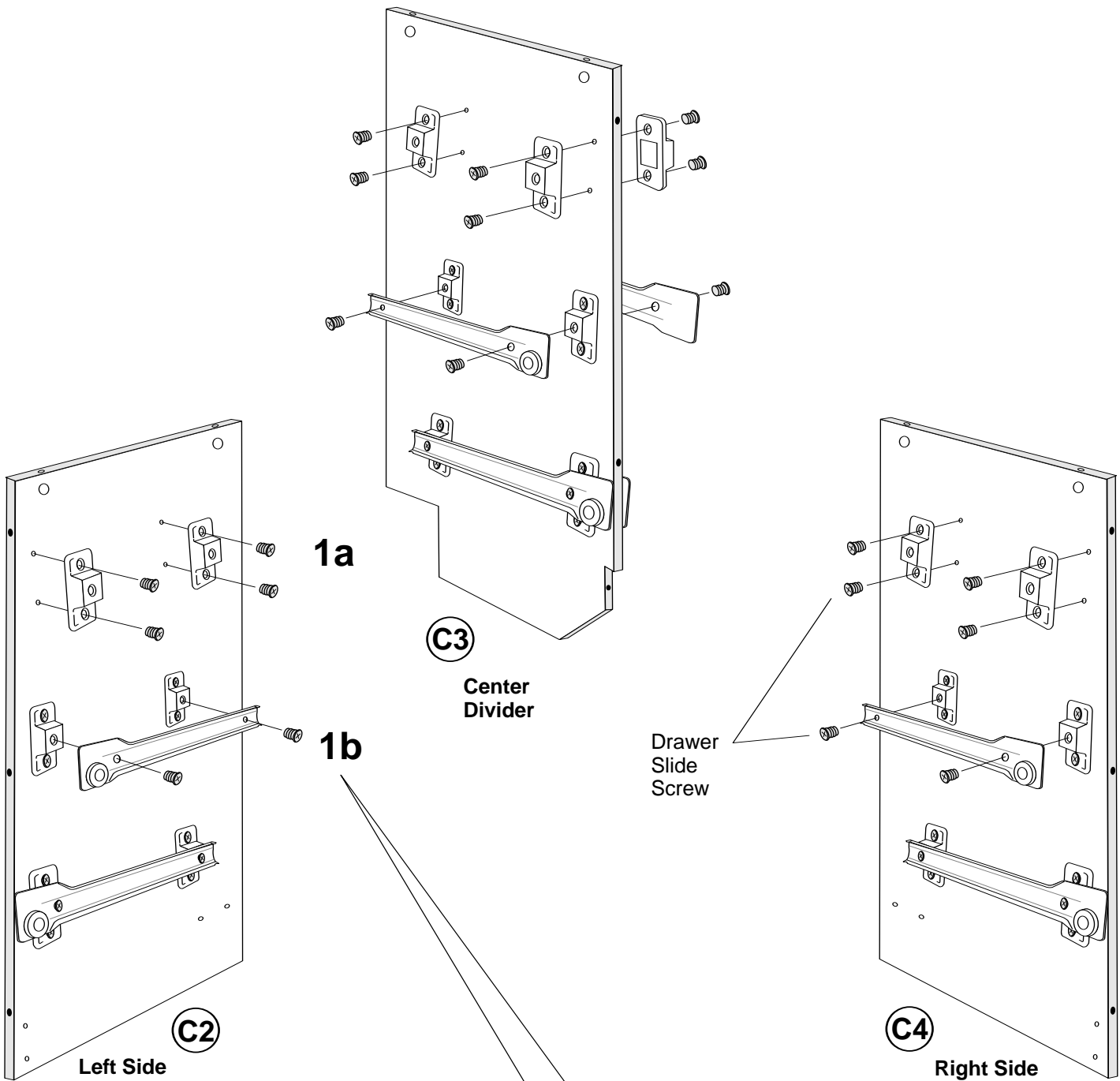

STEP 2 Estimated Time: 1 minute

Insert cams into holes on the top of each side

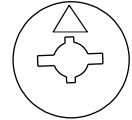
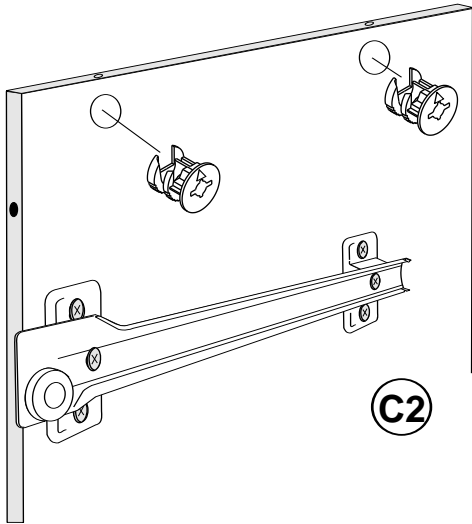

Make sure arrow on cam faces top

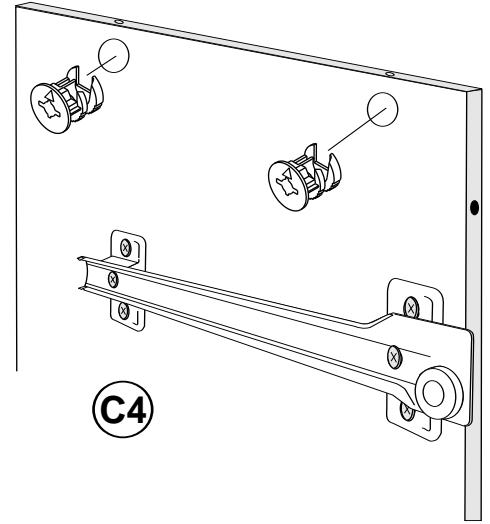

STEP 3 Estimated Time: 1 minute

On the center divider, insert cams where shown

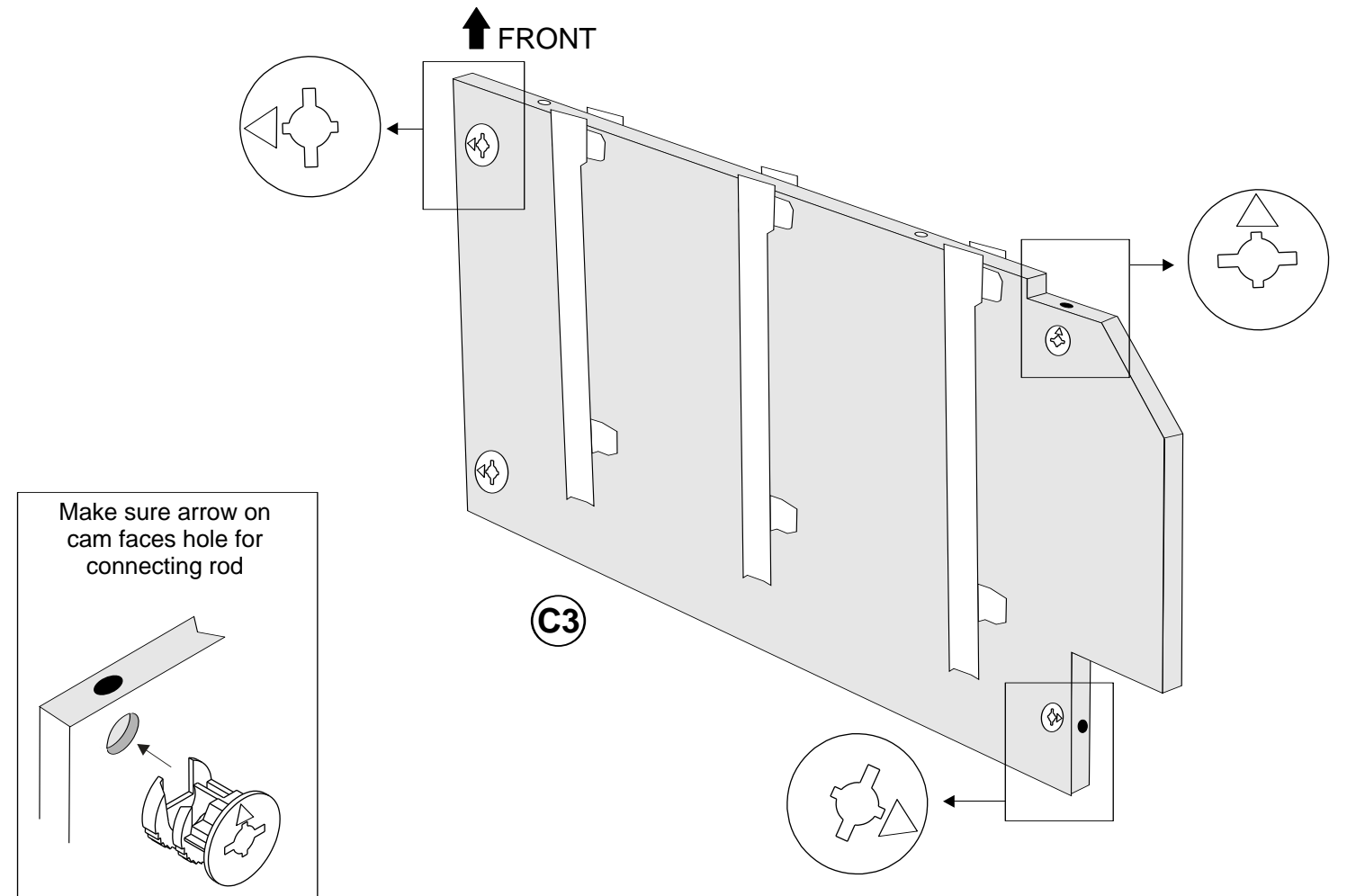

Make sure arrow on cam faces hole for connecting rod

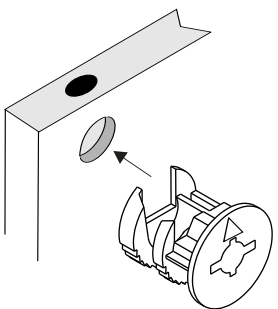

STEP 4 Estimated Time: 1 minute

Insert Blue Rapid Rod into the center hole on each decorative stabilizer

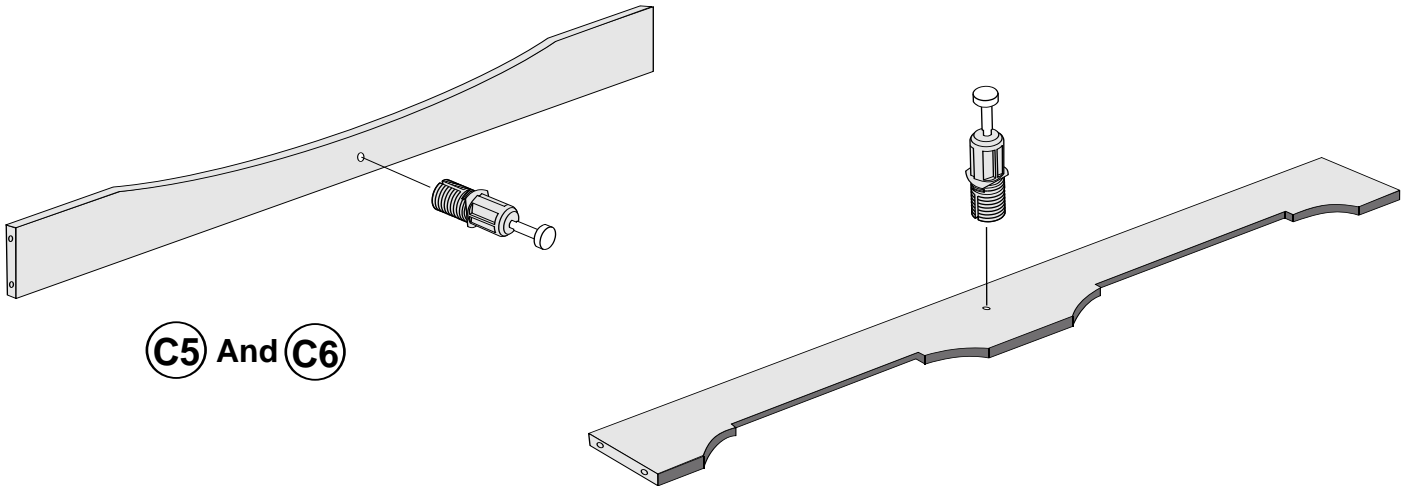

C5 And **C6**

STEP 5 Estimated Time: 5 minutes

Decorative stabilizers **C5** & **C6** are interchangeable.

- 5a** Choose the style that you prefer, and attach it to the front of the center divider
- 5b** Attach the remaining stabilizer to the back of the center divider
- 5c** Lock both cams with a flat head screwdriver

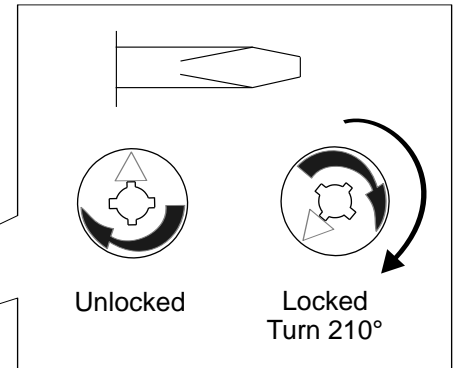
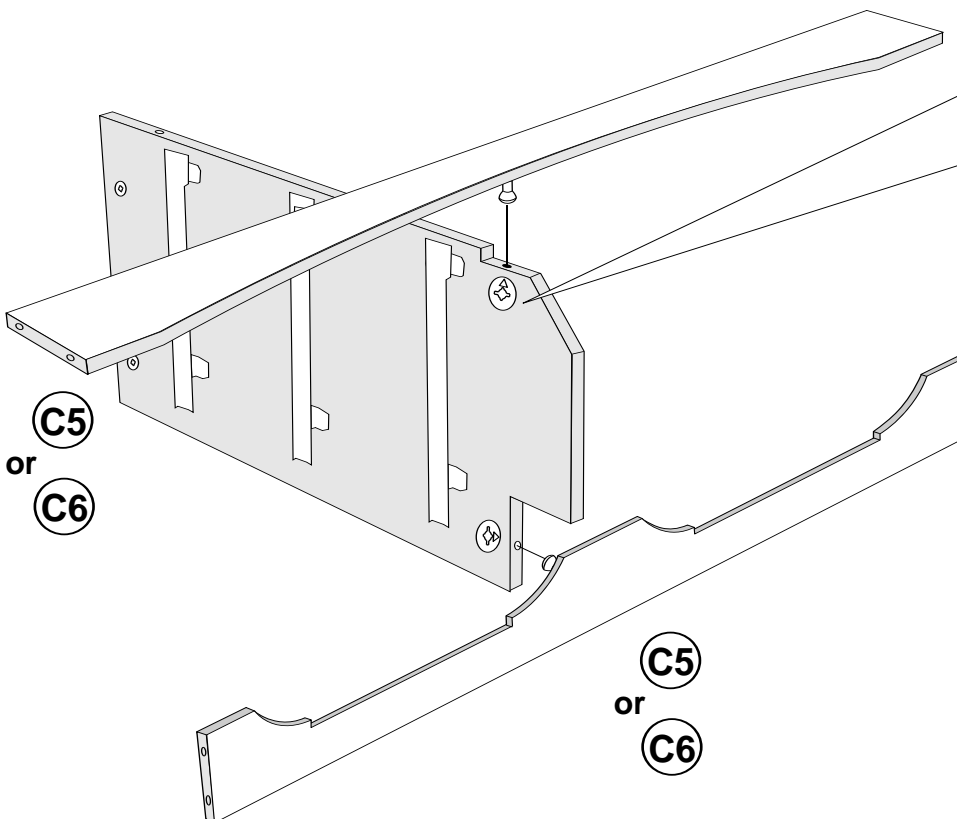

Unlocked

Locked
Turn 210°

STEP 6 Estimated Time: 10 minutes

Attach both stabilizers to left and right sides using Confirmat screws.
Insert screw cover caps to finish.

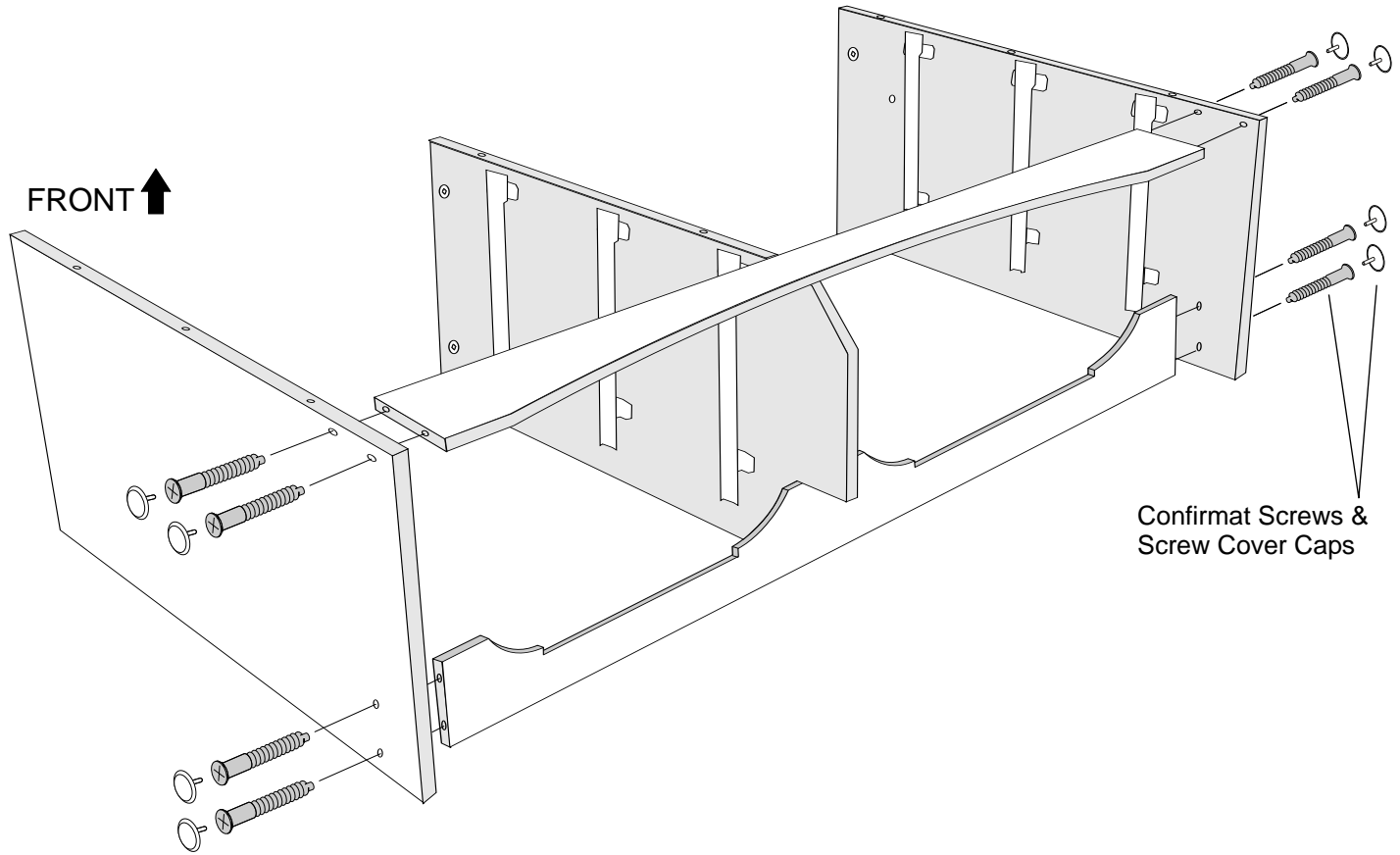

STEP 7 Estimated Time: 3 minutes

Hammer plastic dowels halfway into side, center and top moldings

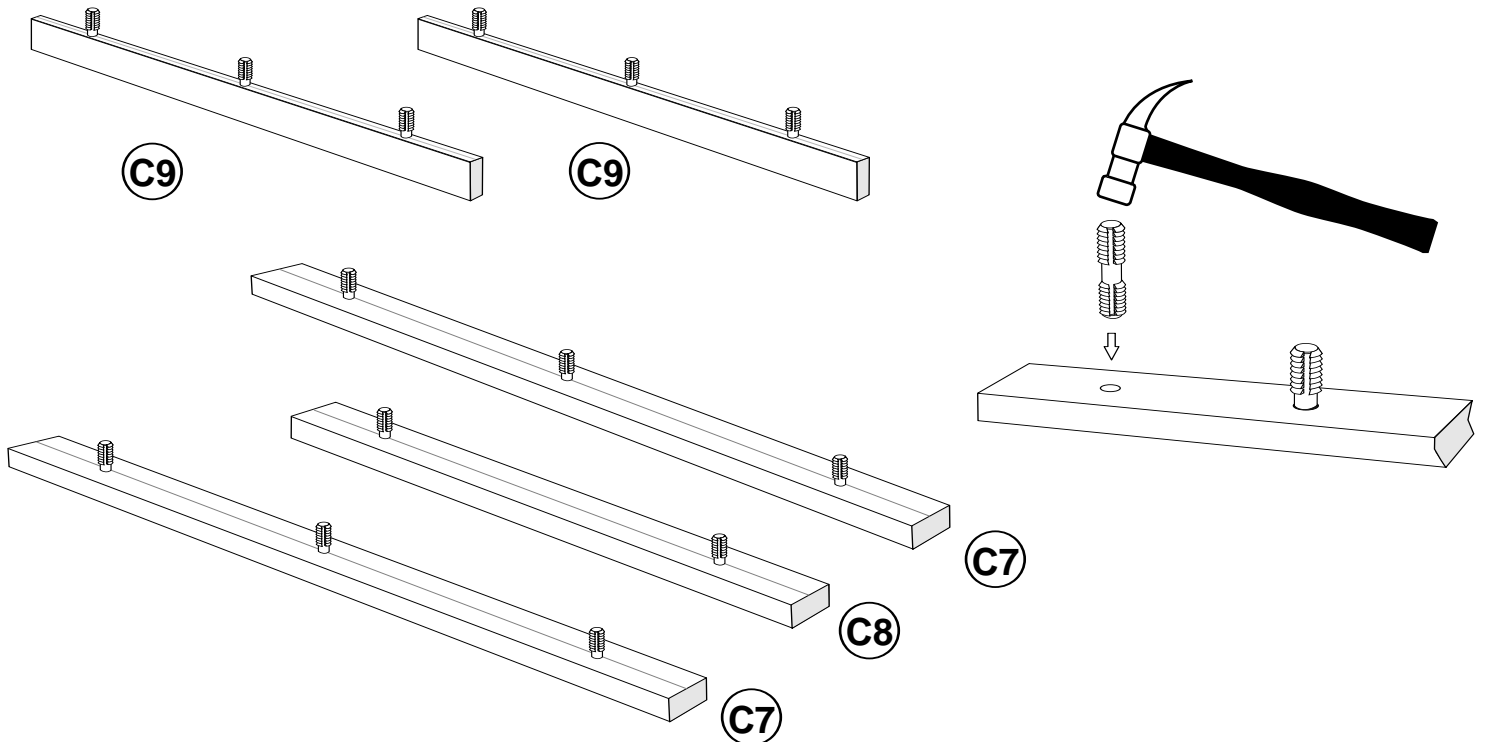

STEP 8 Estimated Time: 2 minutes

Screw **green** twister dowels into the underside of the top

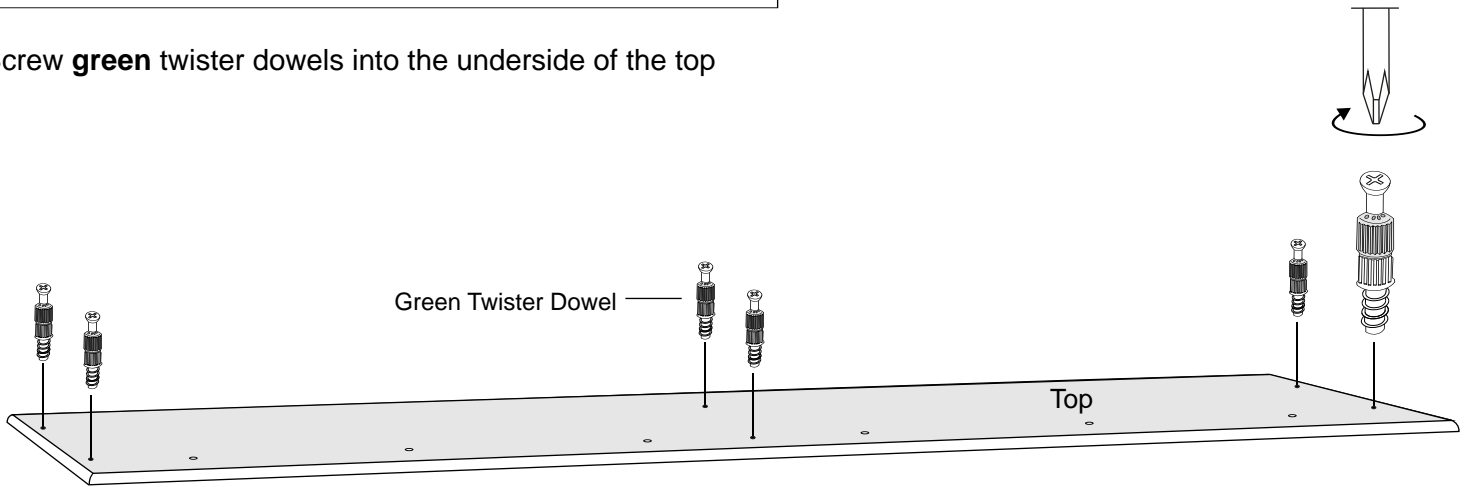

STEP 9 Estimated Time: 2 minutes

Attach top to sides and lock cams using a flat head screwdriver

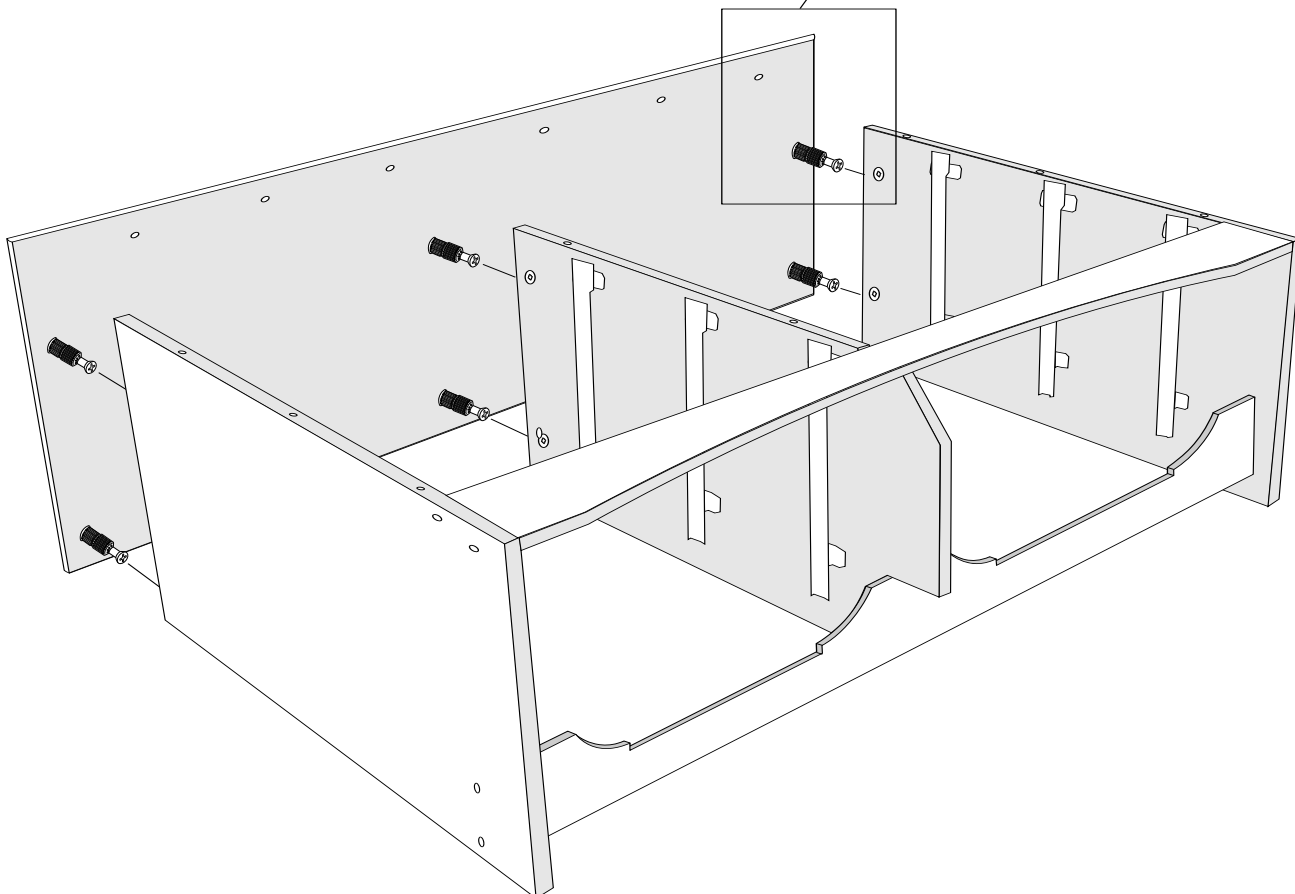
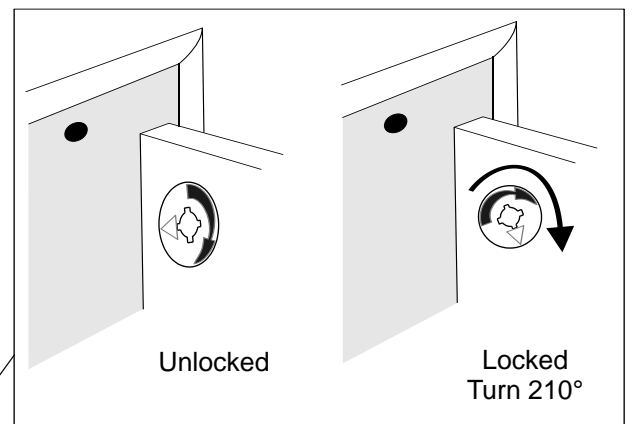
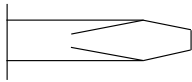

STEP 10 Estimated Time: 3 minutes

Attach top & side moldings.
Using your hands, apply even pressure to moldings and press firmly

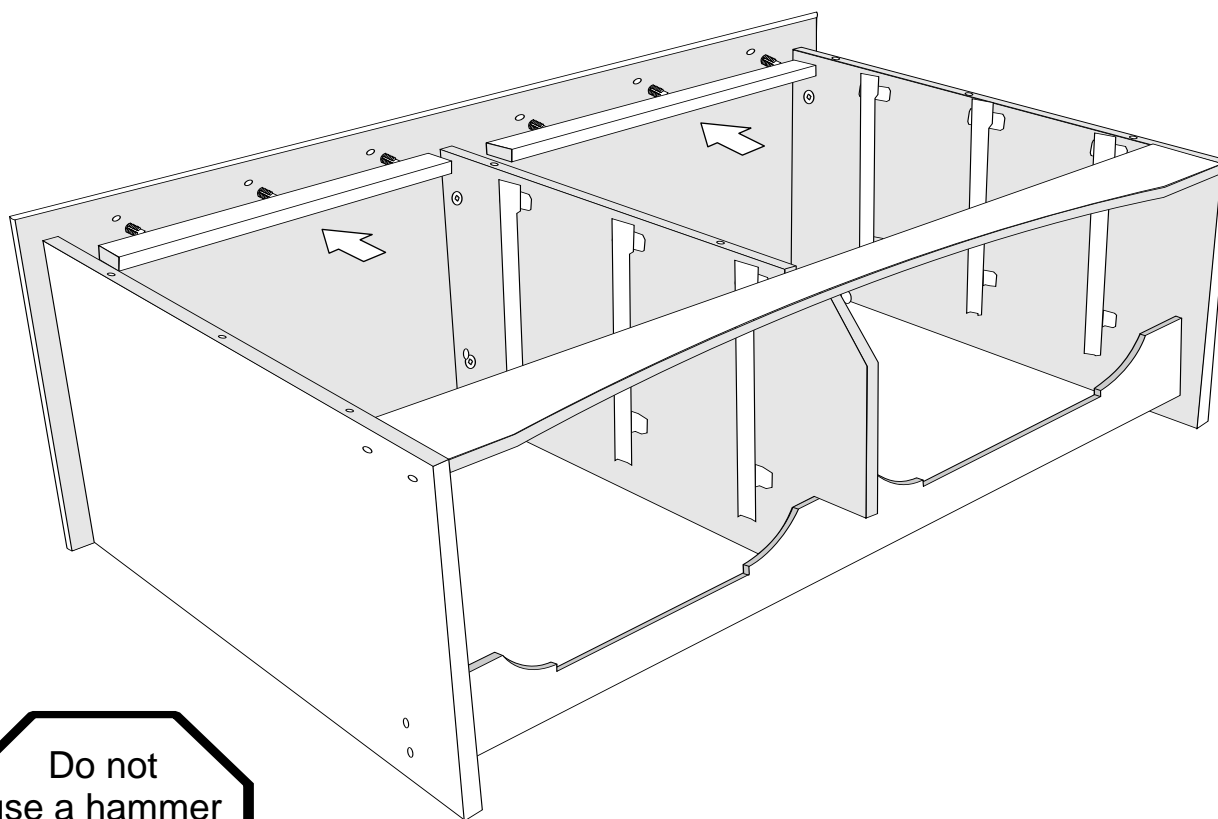

Do not
use a hammer
It may damage
the molding

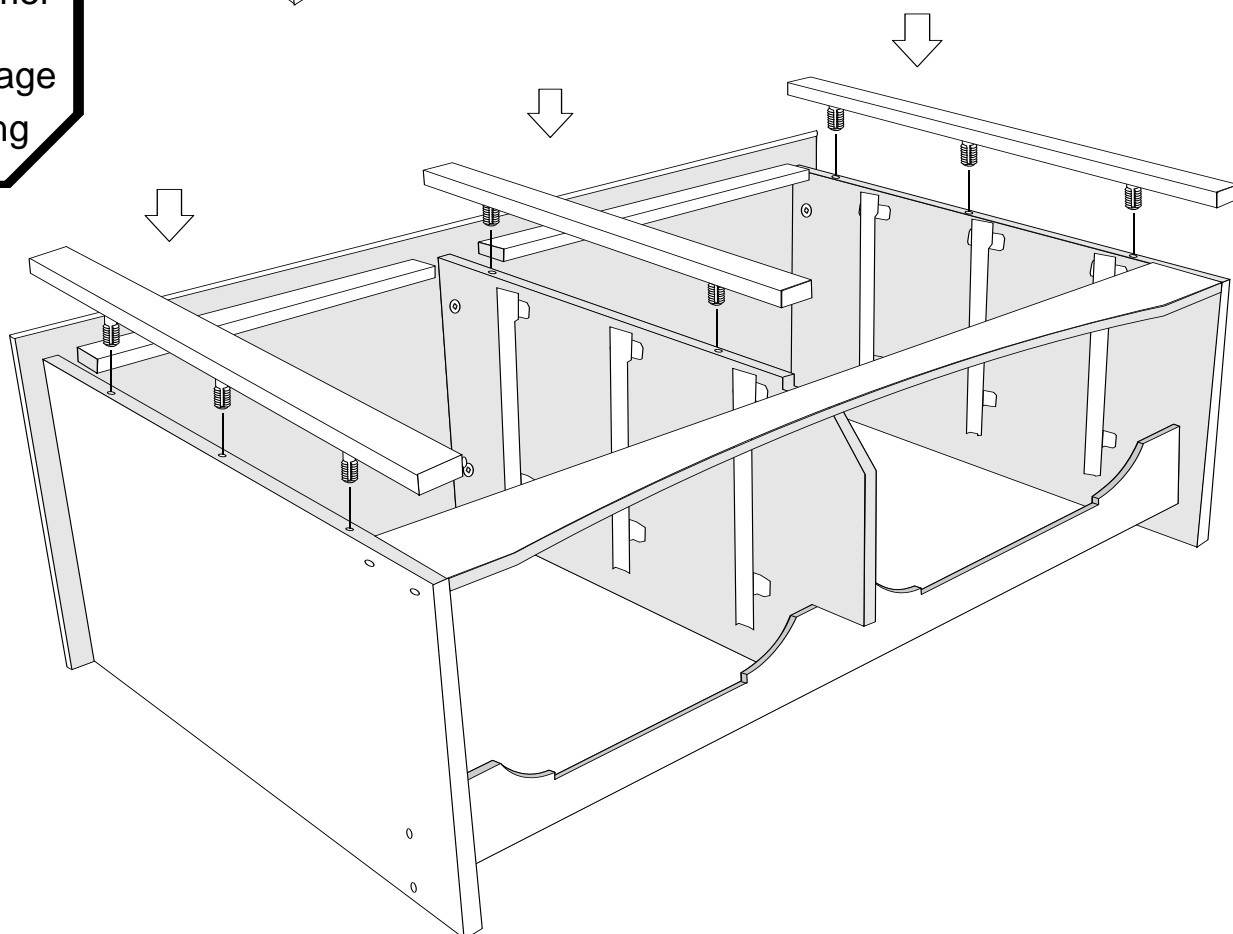

STEP 11 Estimated Time: 4 minutes

Carefully turn dresser over and attach backer

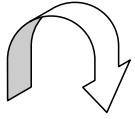

Nail backer as indicated. You may have more nails than are necessary

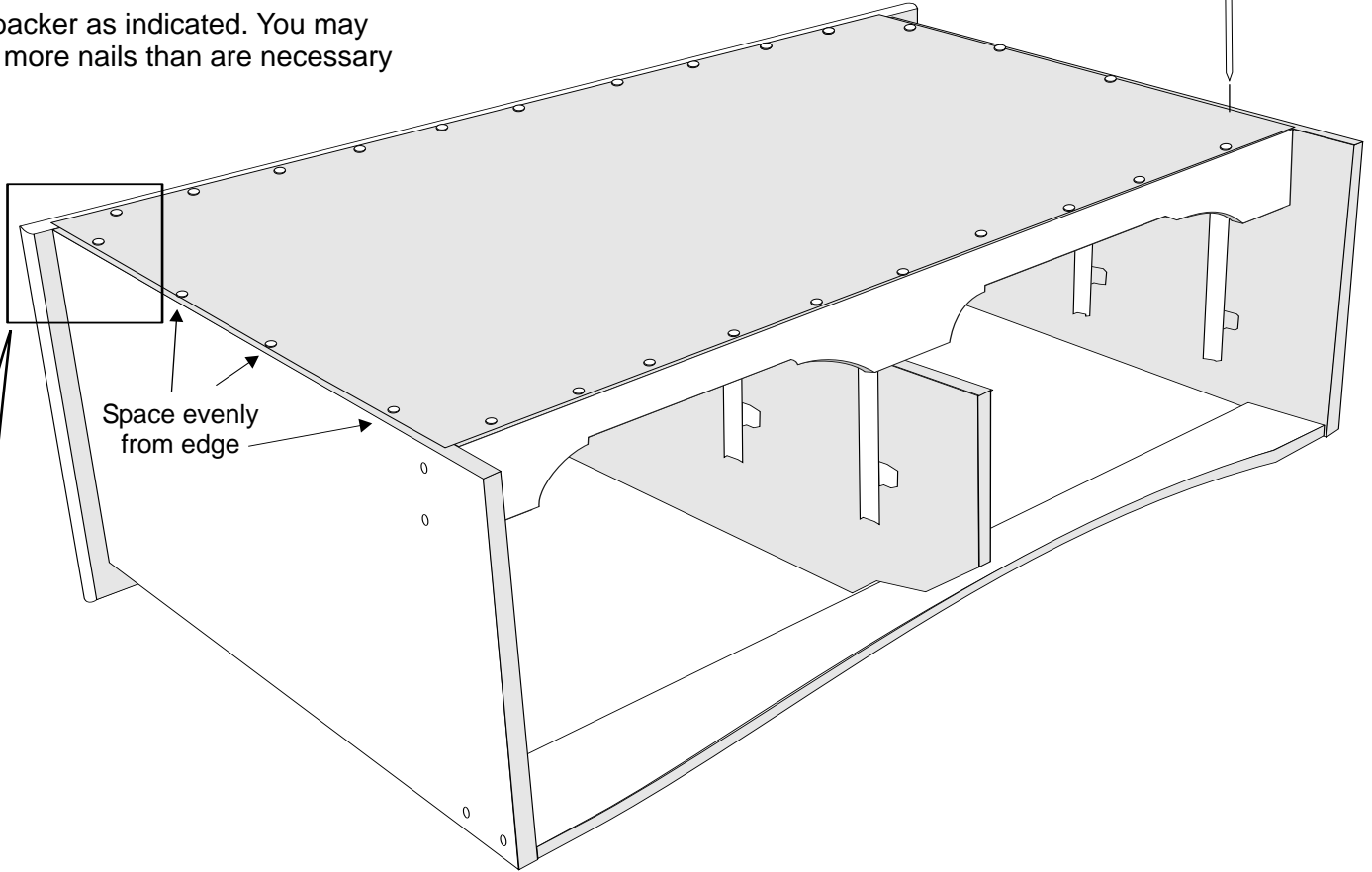

Space evenly from edge

Position nails in the center of the board

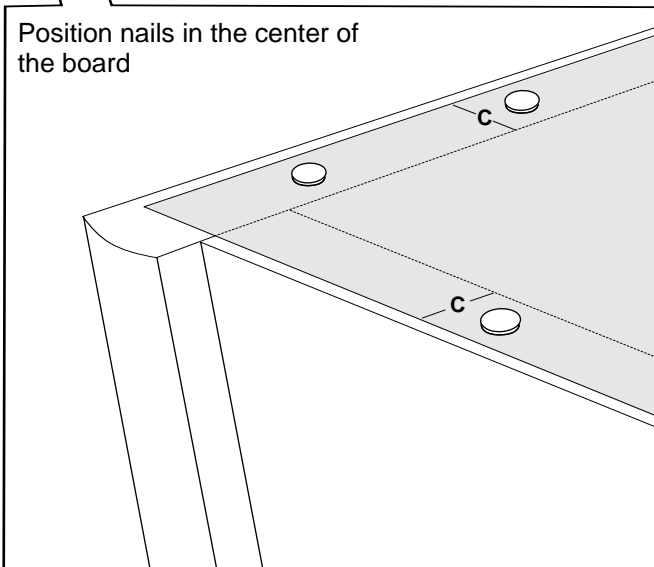

NOTE:
Do not stand product up without the backer fastened

Drawer Parts Identification

D1

Drawer Front (6)
black
cherry
espresso
maple
white

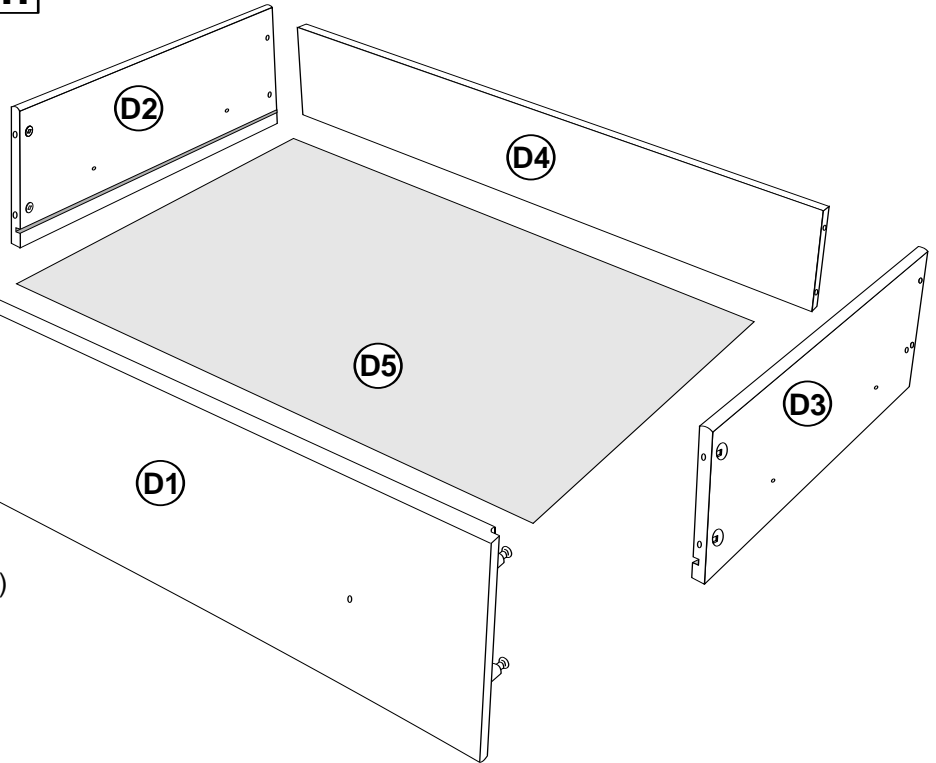

D2

Left Drawer Side (6)

D3

Right Drawer Side (6)

D4

Drawer Back (6)

D5

Drawer Bottom (6)

Unfinished

STEP 12 Estimated Time: 5 minutes PER DRAWER

12a Insert cams into drawer sides

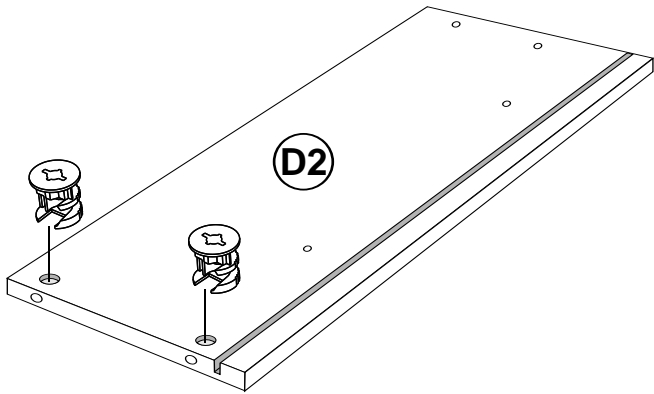

Left Drawer Side

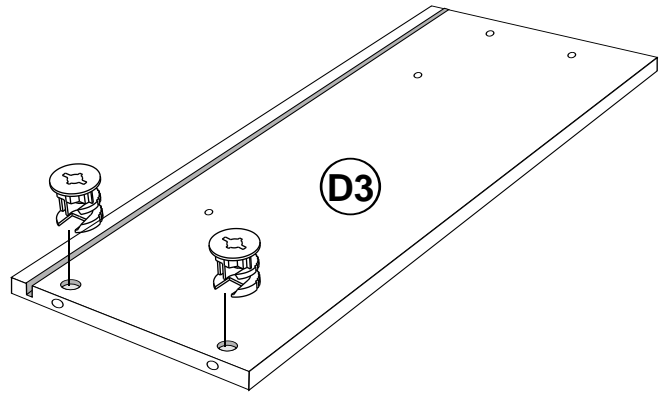

Right Drawer Side

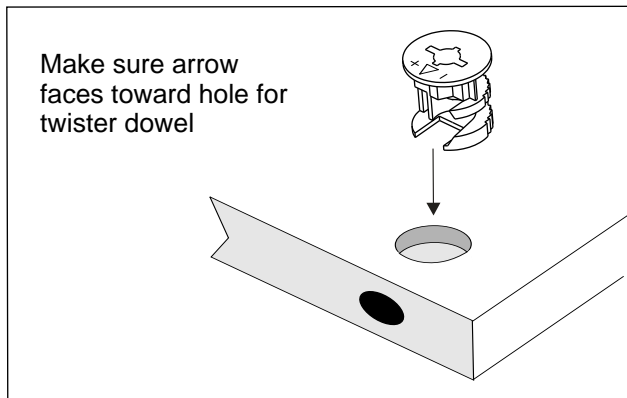

12b Screw **black twister** dowels into drawer fronts

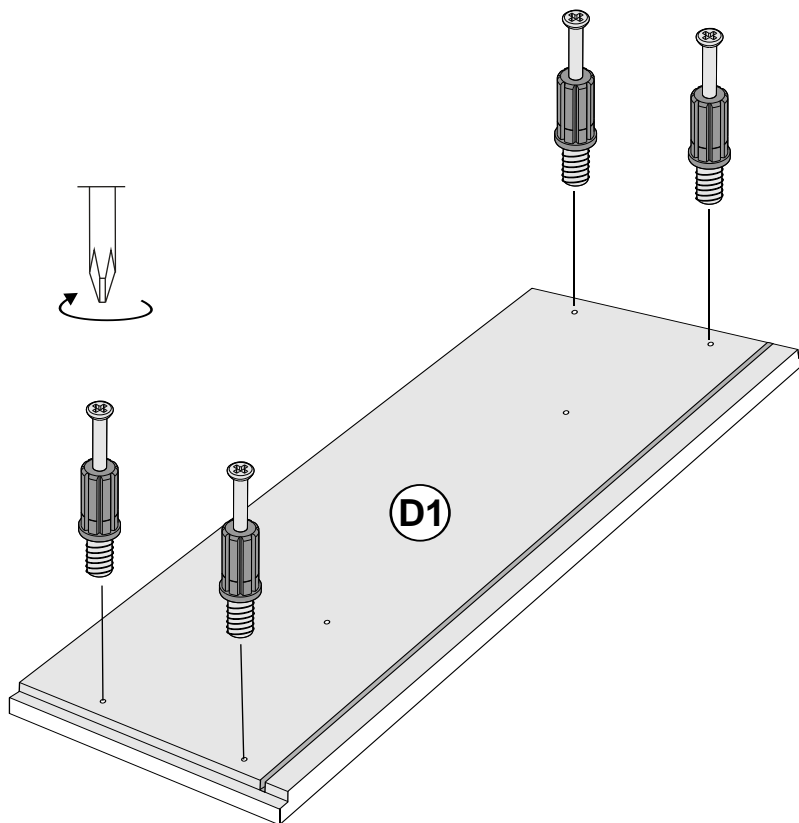

12c Attach drawer sides to drawer back with 1½" Hi Lo screws

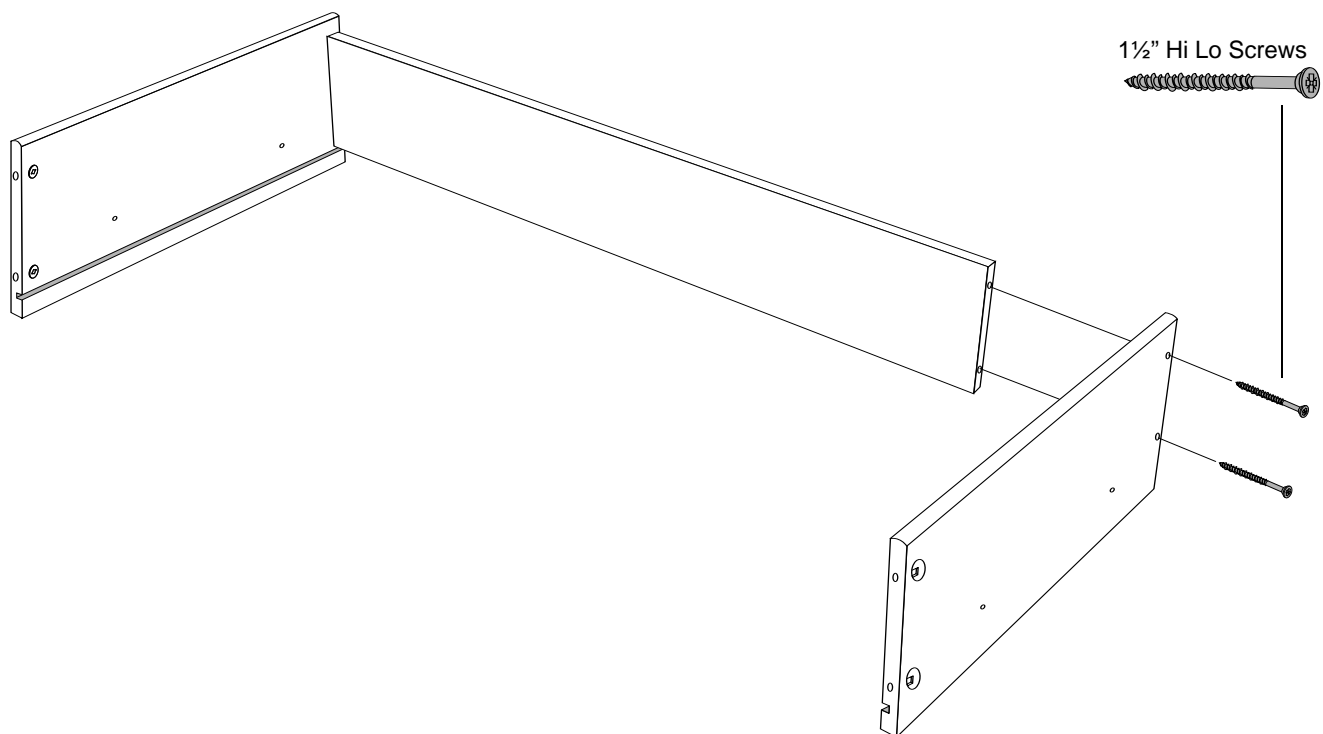

12d Attach drawer front and tighten cams using a flat head screwdriver

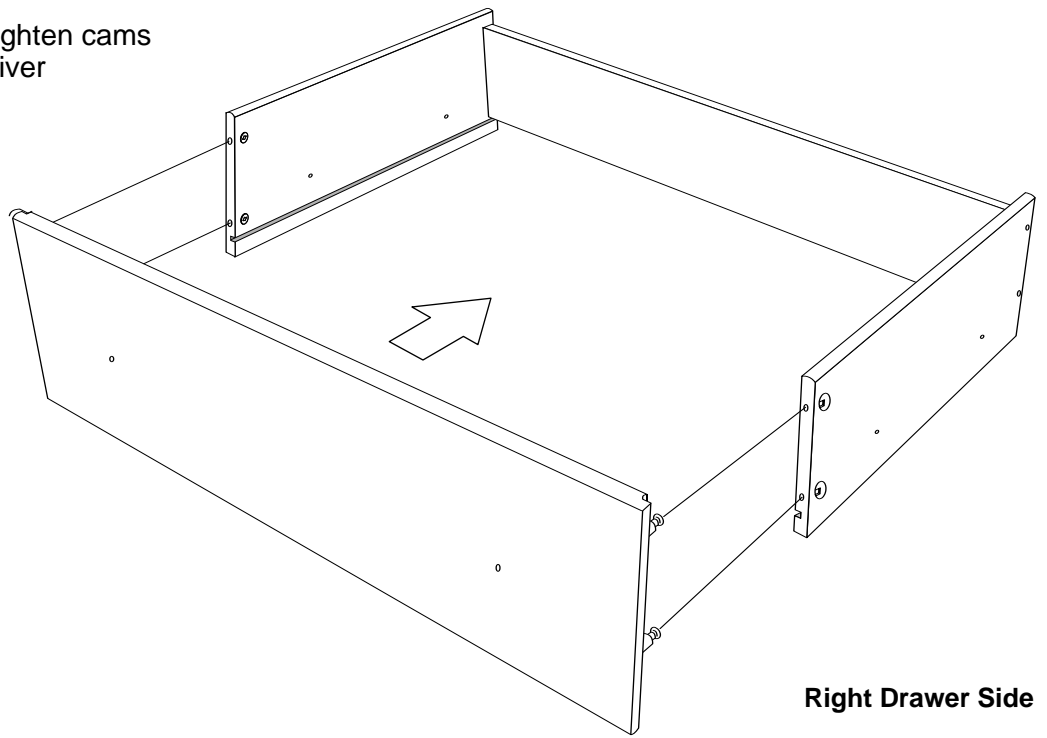
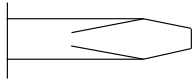

Left Drawer Side

Right Drawer Side

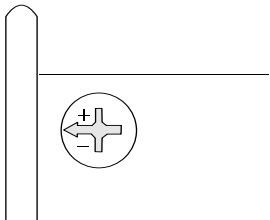

Unlocked

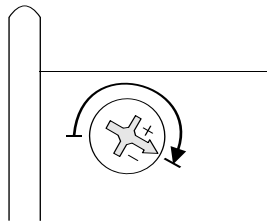

Locked
Turn 210°

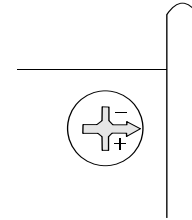

Unlocked

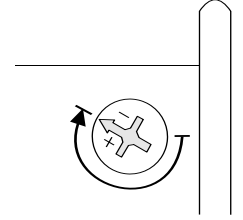

Locked
Turn 210°

12e Turn drawer upside down and slide drawer bottom into grooves

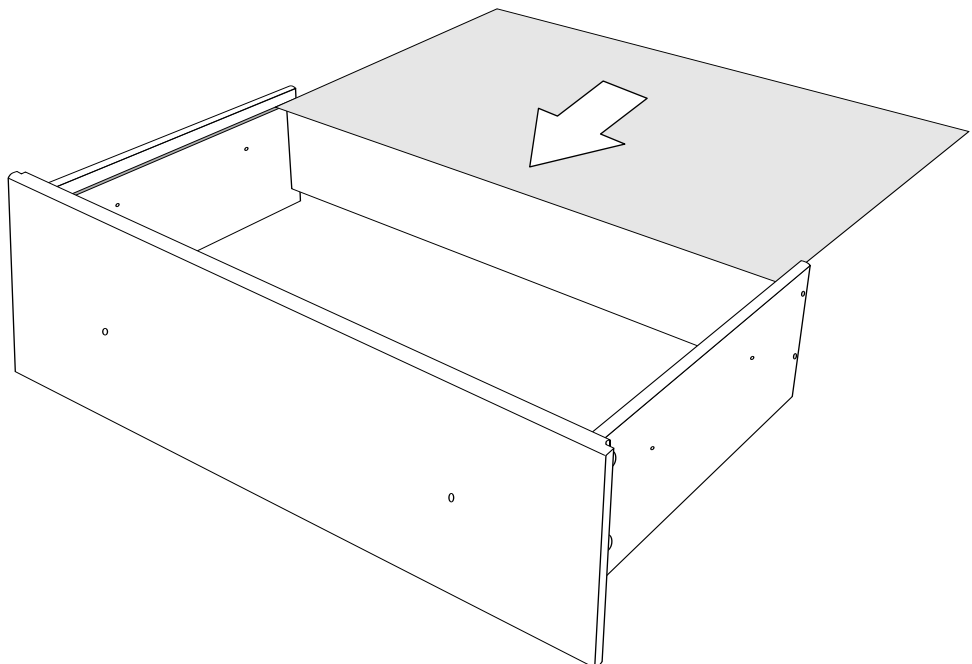
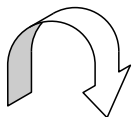

12f Secure the drawer bottom to the drawer back with nails

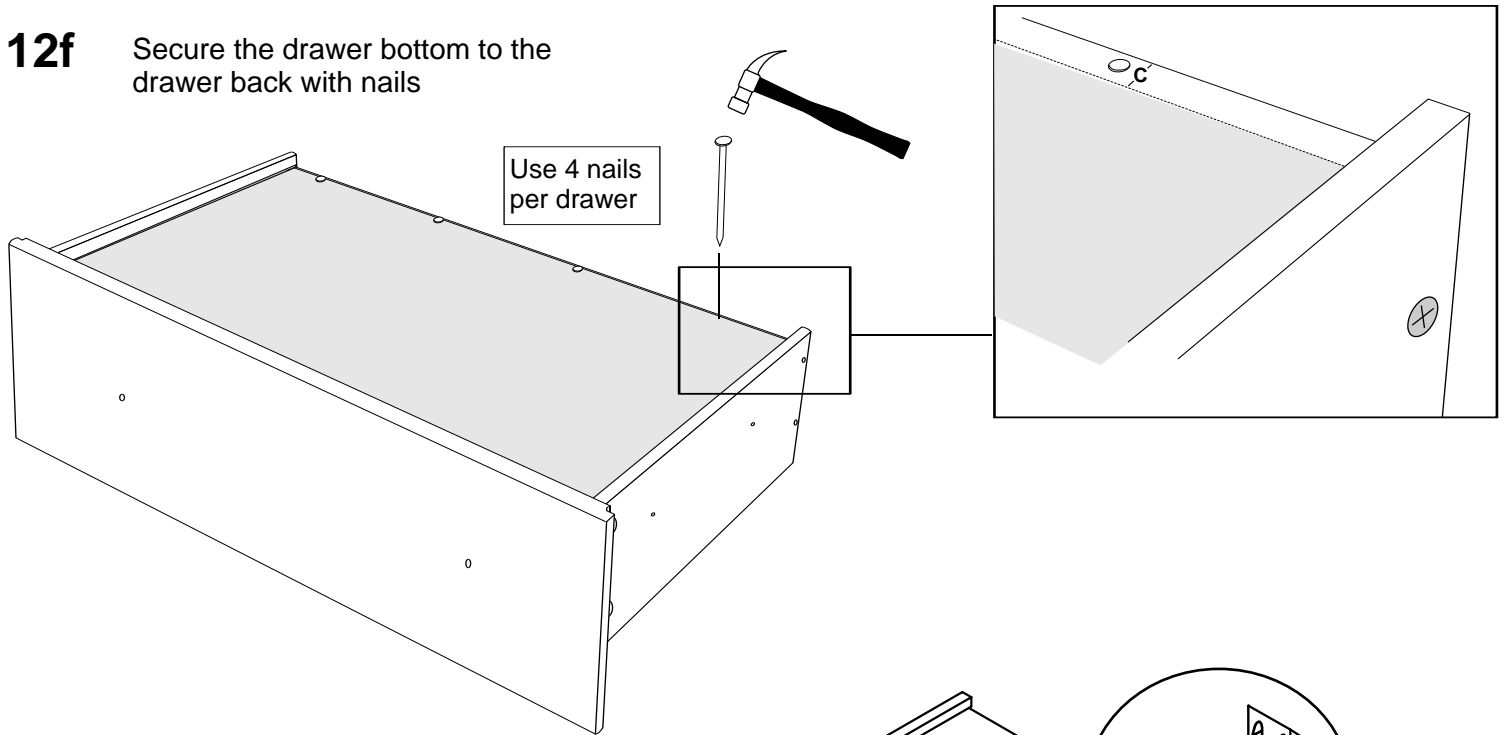

12g Insert the Drawer Bottom Stabilizer

Position the Stabilizer in the center of the drawer and insert it into the groove on the drawer front. This is the same groove that you inserted the drawer bottom into.

Then, tighten screw until it is flush

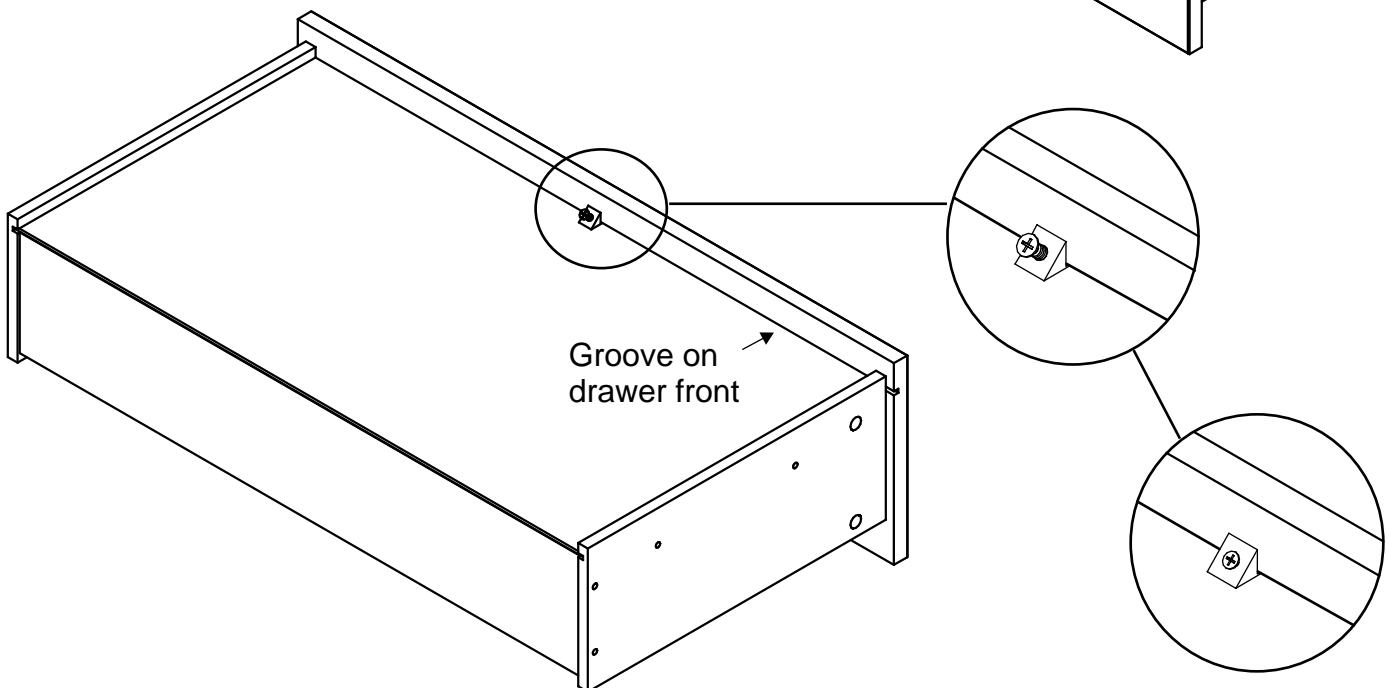
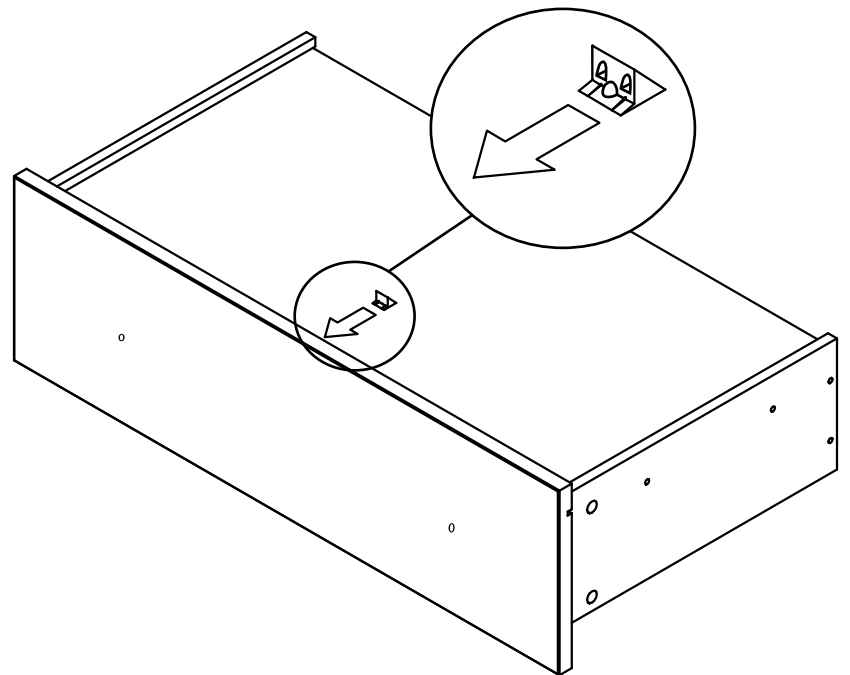

12h Attach drawer slides to left and right drawer sides using drawer slide screws

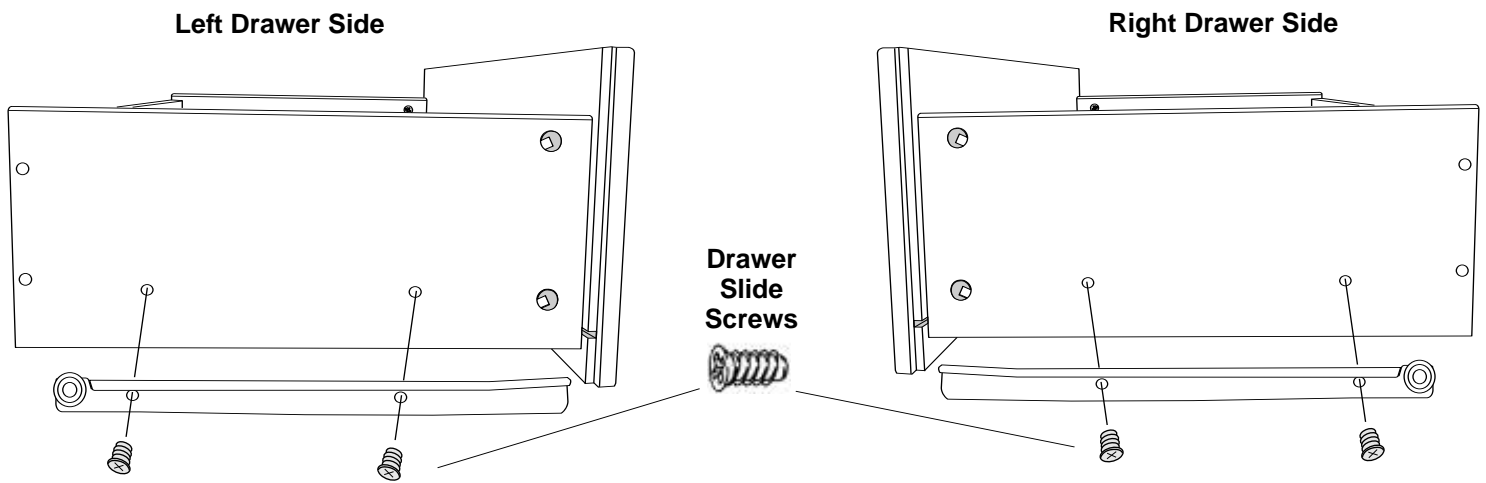

12i Attach knobs with machine screws

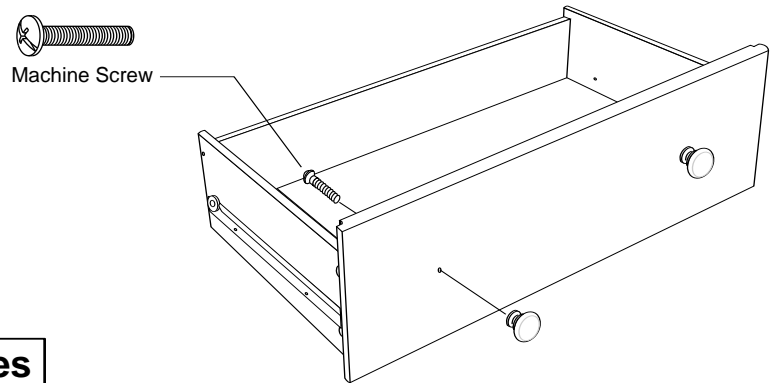

STEP 13 Estimated Time: 2 minutes

Insert drawers

A.

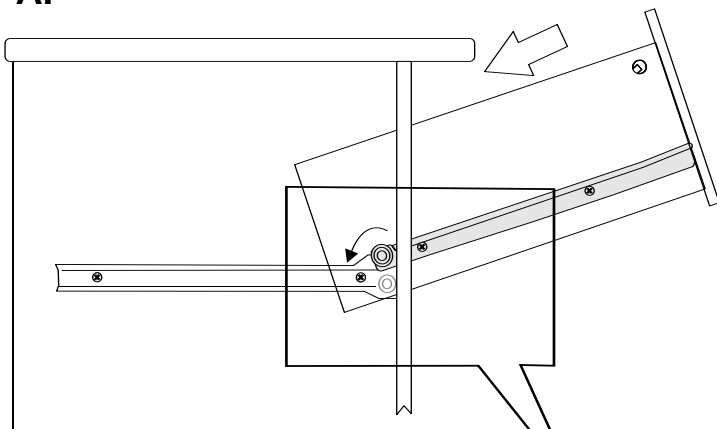

B.

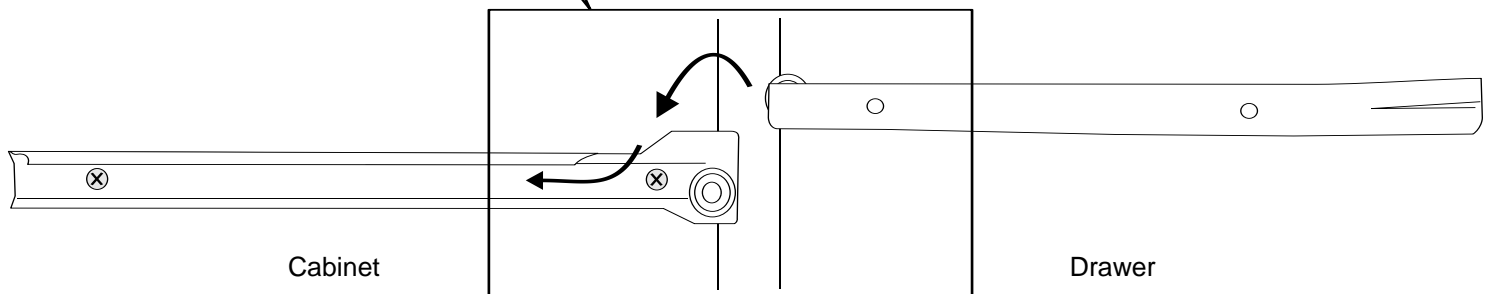
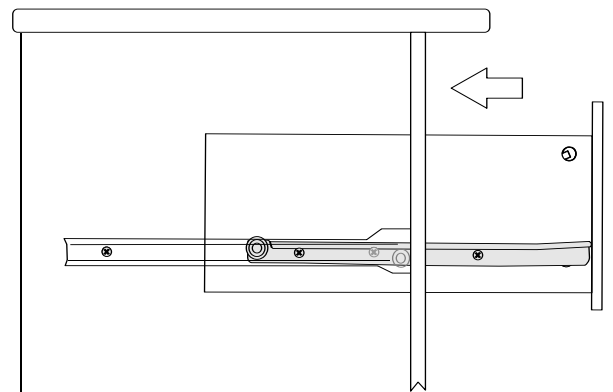

Note: When drawers are installed correctly, you will not be able to remove them without first lifting up the drawer front.

STEP 14 Attaching and Using the Cable Tie

We strongly recommend using a cable tie on all furniture, especially if small children have access

- 14a.** With the #6-3/4" screw, attach one of the mounting bases to one of the sides 1 inch from the top.

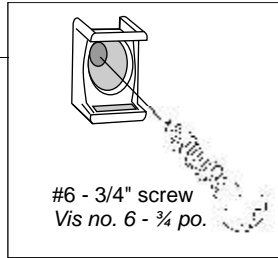
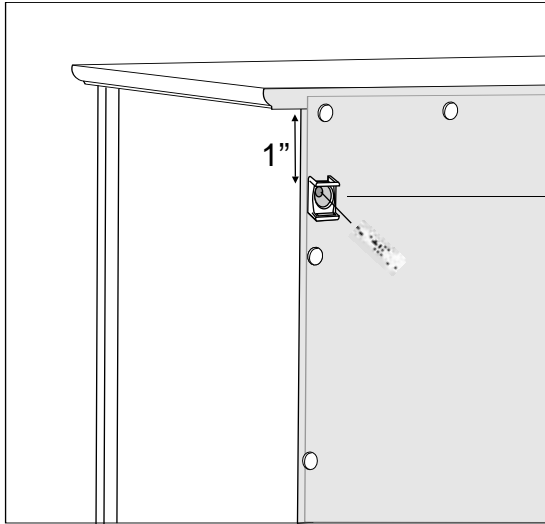

- 14b.** Attach the 2nd mounting base to the wall 2" lower than the one on the cabinet

Important: Find a wall stud and attach the mounting base with a 1 1/2" screw (not included). If you cannot locate a stud, use an approved wall mounting system

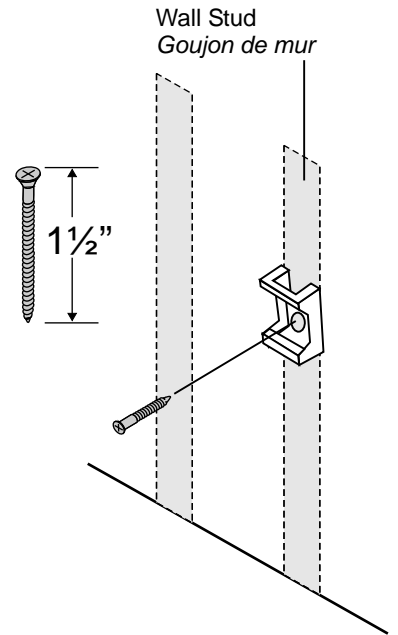

- 14c.** Feed the cable tie through each mounting base and then through the locking mechanism to tighten.

