

# HIGH RISE LIFT TRUCK - HIPM-2048-AC

APPROX WEIGHT: 501.82 lbs.  
 DOES NOT INCLUDE WEIGHT OF POWER OR PACKAGING!!!

\*\*\* ANY ADDITIONS, DELETIONS, OR OMISSIONS MUST BE CORRECTED ON THIS DRAWING AS THIS DRAWING WILL BE CONSIDERED ALL INCLUSIVE \*\*\*

ALL GRAPHICS PROVIDED ARE FOR REFERENCE ONLY. IF CERTAIN DIMENSIONS ARE CRITICAL PLEASE VERIFY THOSE DIMENSIONS WITH YOUR SALESPERSON

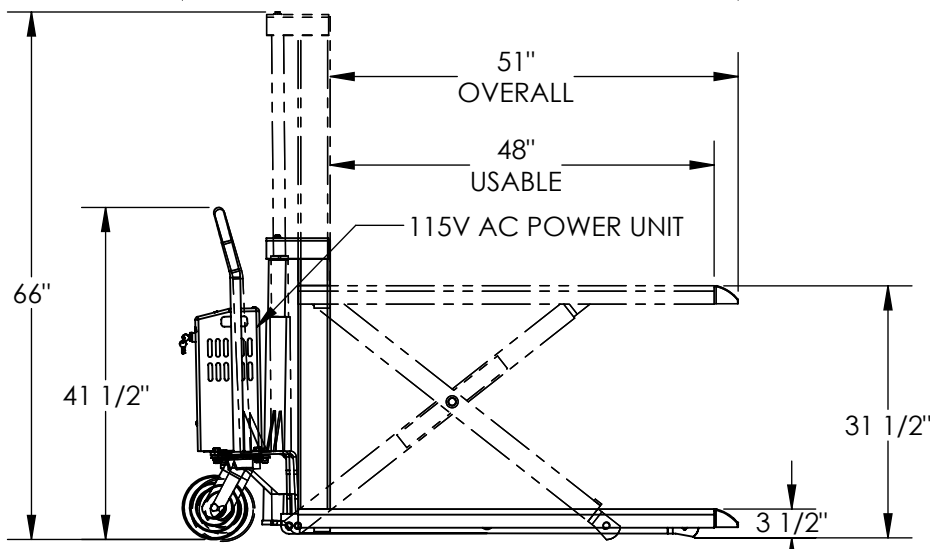
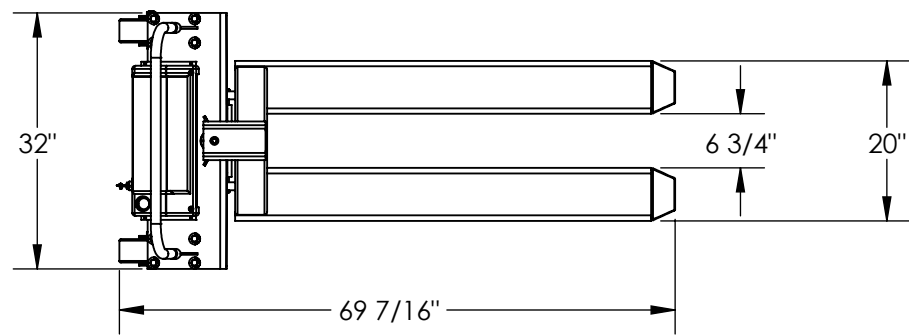

For use with open  
bottom pallets only

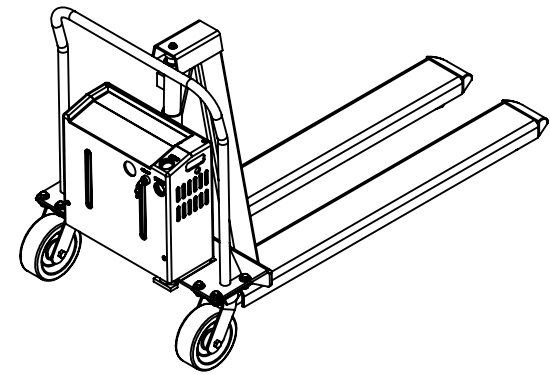

DIMENSION TOLERANCE ± 1/4"

## STANDARD FEATURES

- MODEL NUMBER IS HIPM-2048-AC
- OVERALL WIDTH IS 32"
- OVERALL LENGTH IS 69 7/16"
- OVERALL LOWERED HEIGHT IS 41 1/2"
- OVERALL RAISED HEIGHT IS 66"
- FORK WIDTH IS 20"
- USABLE FORK LENGTH IS 48"
- LOWERED FORK HEIGHT IS 3 1/2"
- RAISED FORK HEIGHT IS 31 1/2"
- MAX CAPACITY IS 2500 LBS
- FOR USE WITH OPEN BOTTOM SKIDS ONLY
- POWER SPECIFICATIONS: AC 115V WITH HAND HELD PENDANT CONTROL

## SPECIAL FEATURES

NONE

APPROVAL	I, THE UNDERSIGNED, AGREE THAT THE PRODUCT AS REPRESENTED SATISFIES DESIGN AND DIMENSION REQUIREMENTS. I ALSO ACKNOWLEDGE MY DUTY TO CONFIRM PRODUCT AND INSTALLATION COMPLIANCE WITH ALL APPLICABLE FEDERAL, STATE AND LOCAL REGULATIONS AND STANDARDS.	
	<b>ANY MODIFIED UNITS ARE NON-RETURNABLE</b>	
	[ ] As drawn      [ ] As marked	
Signed: _____		Date: _____
Printed Name: _____		
<b>LEAD TIME WILL START UPON RECEIPT OF SIGNED APPROVAL DRAWING</b>		

FOR INTERNAL USE ONLY PROJECT SIGN OFF	
SALES	
ENG.	
FAB.	
POWER	

DISTRIBUTOR'S NAME:		P.O.#
VESTIL MANUFACTURING		X
DRAWN BY:	DATE:	W.O.#
KGH	7/27/2016	X
REFERENCE:	SCALE:	FILE NAME:
X	1:24	15-007-033-002
QUOTED LEAD TIME:	QUOTE #	
X	X	