









Assembly Instructions

Caution : You must read this before you proceed

Care & Maintenance

- ⊘  ● Not for commercial use. For residential use only.
- ⊘  ● Do not put hot items directly on furniture surface.
- ⊘  ● Do not clean furniture with harsh cleansers or polish.
- ✓  ● To obtain the longest lifespan of your outdoor products, minimizing exposure to direct sunlight is recommended.
- ⊘  ● Children should not climb or jump on the furniture.
- ⊘  ● Do not write on furniture without a padded barrier to protect the surface.
- ✓  ● To obtain the longest lifespan of your outdoor products, avoid extended and lengthy exposure to rain, snow, and direct sunshine. Whenever possible cover the product and /or place under patio or awnings.
- ⊘  ● Stains may be removed with mild soap solution and damp cloth.

- ✓  ● Dust and pick-up spills using a clean, non-colored, lint-free cloth.

Please look in boxes for hardware packs and legs.
Sets often ship in multiple boxes and may arrive a day or two apart.

Coffee Table

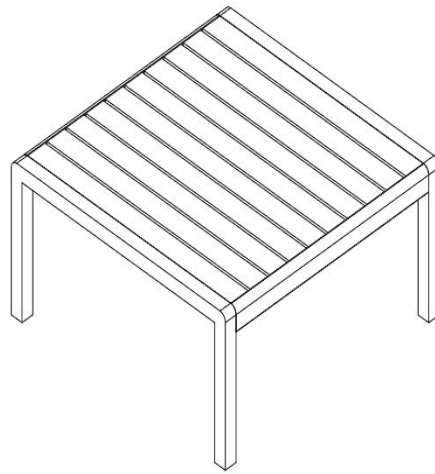

Parts List

Label	Picture	Description	QTY
A	A line drawing of a single leg of the coffee table, showing its L-shaped profile and how it connects to the table top.	Leg	2
B	A line drawing of the slatted table top, showing the parallel slats and the frame around the edges.	Table Top	1

Hardware

Label	Picture	Description	QTY
①	A line drawing of a bolt, showing its hexagonal head and threaded shaft.	Bolt (M6*20MM)	5
②	A line drawing of a bolt, showing its hexagonal head and threaded shaft.	Bolt (M6*25MM)	5
③	A line drawing of an Allen wrench, showing its L-shaped handle.	Allen wrench	1

Assembly Preparation

Before Beginning Assembly:

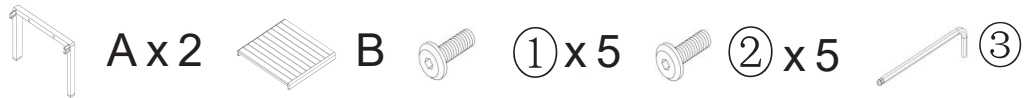

- Read instructions, cover to cover-



- Have 2 adults on hand for assembly-



- Do not assemble on flooring or carpet-



- Assemble on a clean non-marring surface (packing foam)-



- Save all packaging until finished-

Assembly Steps

Overview

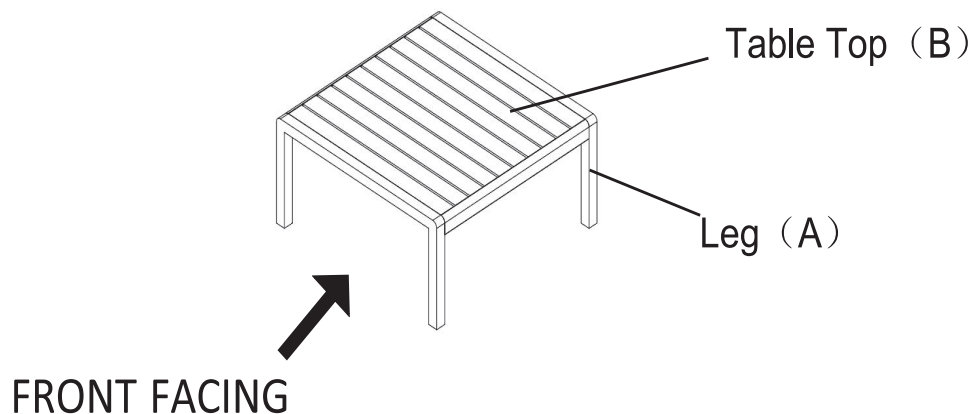

This Table has multiple parts and may require up to 30 minutes to assemble. To give you an overview of the Chair parts, the above picture is to help you put the various parts into perspective. Please read through the instructions below to familiarise yourself with the parts and steps before assembly.

Step 1

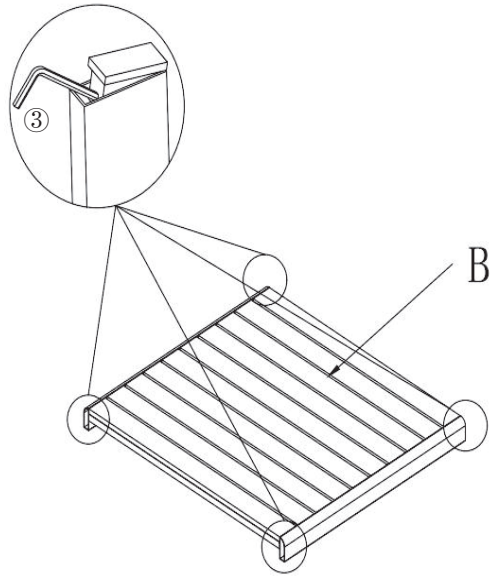

Open the carton and place all parts on a clean, unbroken surface.
As shown in the figure, use the Allen wrench ③ to lift out the tube plug in part B.
If necessary, keep the plastic plug for repackaging.

Step 2

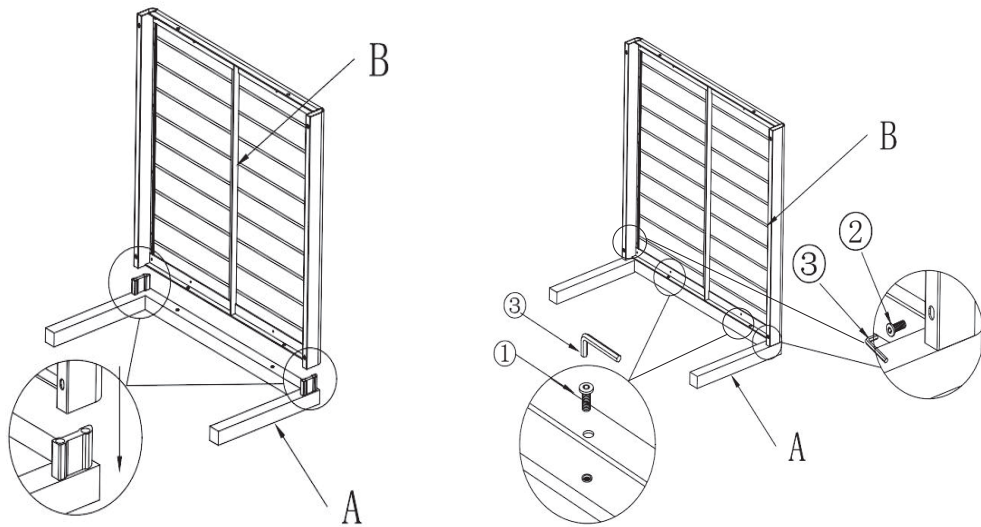

Attach the table top (B) and the leg (A) using the Bolts (①) + Bolt (②) with the Allen wrench (③) as shown in the pictures.
Loosely tighten the Bolts.

Step 3

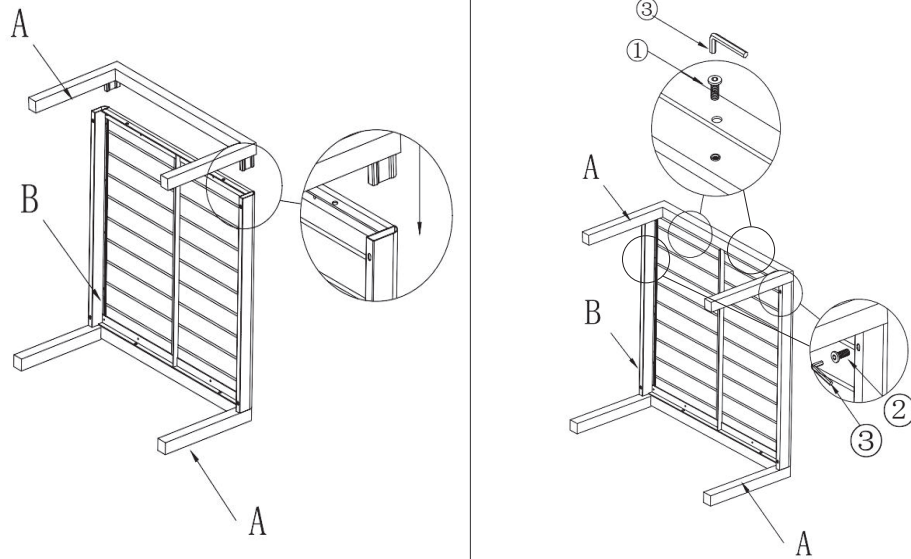

Repeat step 2.

Attach the table top (B) and the leg (A) using the Bolts (②) + Bolt (①) with the Allen wrench (③) as shown in the pictures.

Loosely tighten the Bolts.

Step 4

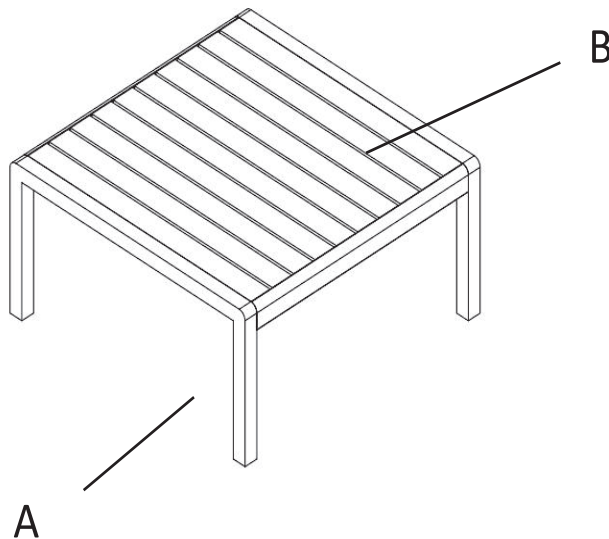

Stand up the table, check stability and then tighten the bolts.

Note DO NOT fully tighten a BOLT in one go and then move on to the next. Rather, In a sequential manner, gradually tighten each Bolt until all bolts are evenly secured. This methodology will ensure maximum evenness once all Bolts are fully tightened.