

Storage Cabinet 4.7x2.5FT

instructions for assembly

If you have any questions about the product, please feel free to contact us.

E-Mail: Patiofurnitureserviceteam@outlook.com

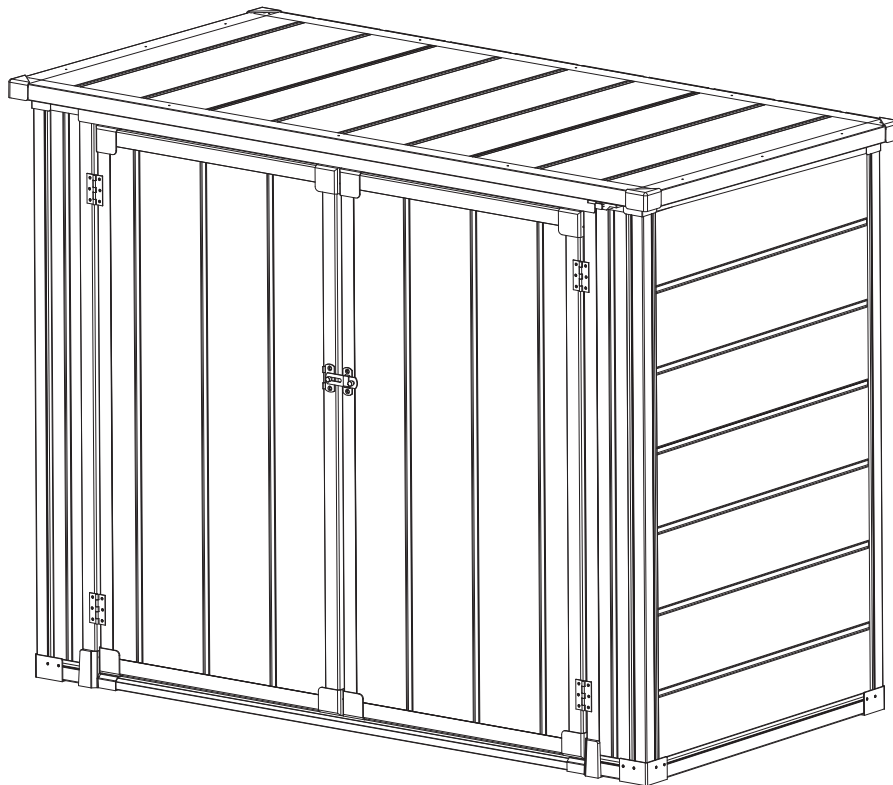

After-sales mailbox:
Patiofurnitureserviceteam@outlook.com

SITE PREPARATION | PRÉPARATION DU SITE | PREPARACIÓN DEL LUGAR | VORBEREITUNG DES AUFSTELLUNGORTES | VOORBEREIDING VAN HET TERREIN | PREPARAZIONE DEL LUOGO DI ASSEMBLAGGIO | PREPARAÇÃO DO LOCAL

Level the ground surface | Nivelez la surface du sol | Nivele la superficie del suelo | Ebenen Sie die Bodenoberfläche | Maak de bodem vlak | Livellare la superficie del terreno | Nivele a superficie do solo

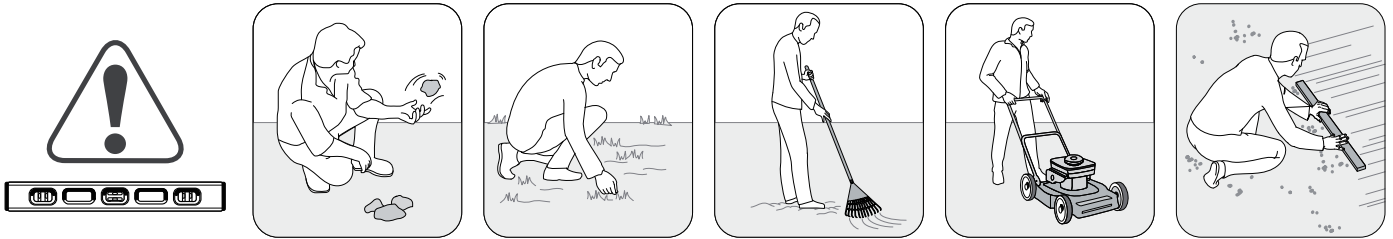

Recommendation: Construct a wooden or concrete base as a foundation | Recommandation: fabriquez une base en bois ou en béton en guise de fondation | Recomendación: construya una base de madera o de cemento a modo de cimiento | Empfehlung: Bauen Sie als Fundament eine Grundfläche aus Holz oder Beton | Aanbeveling: maak een houten of betonnen ondergrond als fundering | Raccomandazione: Costruire una base di legno o di cemento come fondamenta | Recomendação: Construa uma base de madeira ou de cimento como fundação

Option | Opción | optie | opzione | opção

A

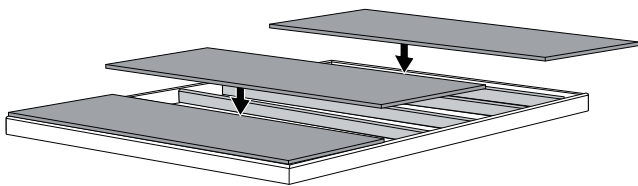

Option | Opción | optie | opzione | opção

B

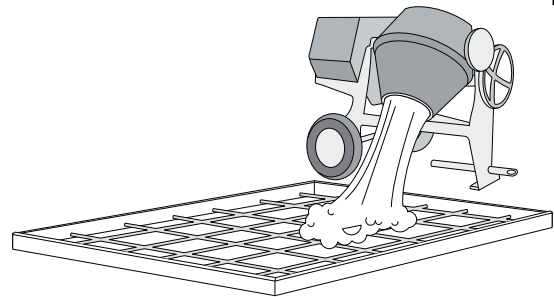

External floor measurements are: | Les mesures externes de la étage sont: | Las medidas del suelo externo son: | Die Außen-Bodenmaße betragen: | De afmetingen van de externe vloer zijn: | Le dimensioni esterne del pavimento sono: | As medidas externas do chão são:

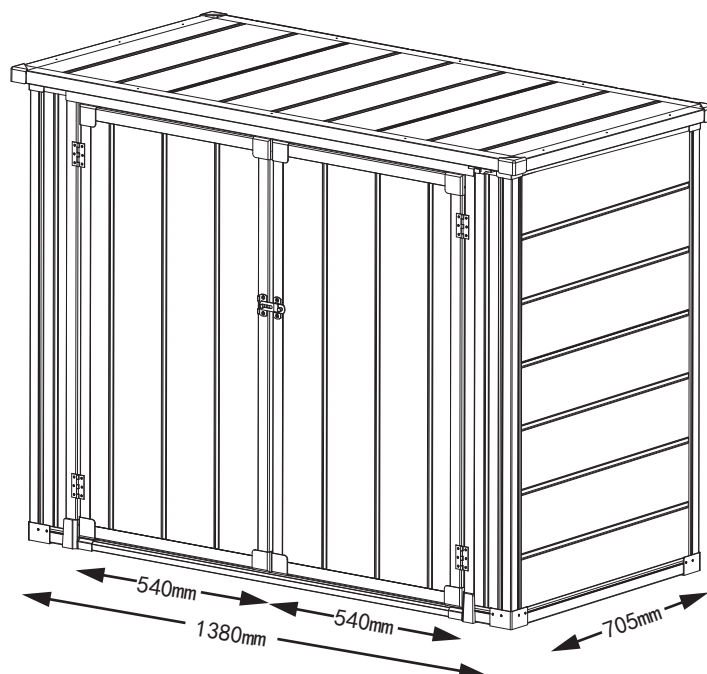

BEFORE STARTING ASSEMBLY | AVANT DE COMMENCER LE MONTAGE | ANTES DE EMPEZAR EL ARMADO | VOR MONTAGEBEGINN | VOORDAT U BEGINT TE MONTEREN | PRIMA DI INIZIARE L'ASSEMBLAGGIO | ANTES DE INICIAR A MONTAGEM

Read the care and safety guidelines at the end of this manual | Check to ensure that there are no missing or damaged parts BEFORE starting or arranging assembly | Remove all parts from the package(s) and spread them out on a clean work surface | Review all assembly instructions | Assemble all the parts according to the directions in this manual. Do not skip any steps.

Lisez les instructions de précaution et de sécurité à la fin de ce manuel | Assurez-vous qu'il n'y a pas de pièces manquantes ou endommagées AVANT de commencer ou d'organiser l'assemblage | Retirez toutes les pièces du/des paquet(s) et étalez-les sur une surface de travail propre | Lisez toutes les instructions de montage | Assemblez toutes les pièces selon les instructions de ce manuel. Ne sautez aucune étape.

Lea las intrucciones de precauciones y seguridad que están al final de este manual | Asegúrese de que no faltan piezas ni están dañadas ANTES de comenzar o disponer el montaje | Saque todas las piezas del paquete o paquetes y póngalas sobre una superficie de trabajo limpia | Revise todas las instrucciones de montaje | Monte todas las piezas según las instrucciones de este manual. No se saltee ningún paso.

Lesen Sie die Sicherheitsrichtlinien am Ende des Benutzerhandbuchs durch | Prüfen Sie bitte VOR dem Zusammenbau, dass keine Teile beschädigt sind oder fehlen | Nehmen Sie alle Teile aus der Verpackung und breiten Sie sie auf einer sauberen Arbeitsfläche aus | Gehen Sie noch einmal die komplette Aufbauanleitung durch | Bauen Sie alle Teile entsprechend der Anleitung in diesem Handbuch zusammen. Lassen Sie dabei keinen Arbeitsschritt aus.

Lees de richtlijnen voor zorg en veiligheid achterin deze handleiding | Controleer dat er geen onderdelen mankeren, of beschadigd zijn, VOORDAT u met de montage begint | Haal alle onderdelen uit het pakket (of uit de pakketten) en leg ze oopen schoon werkoppervlak | Bekijk alle montagehandleidingen | Monteer alle onderdelen volgens de aanwijzingen van deze handleiding. Sla geen stappen over.

Leggere le linee guida di assistenza e sicurezza alla fine di questo manuale | Assicurarsi che non ci siano parti mancanti o danneggiate PRIMA di iniziare l'assemblaggio | Estrarre tutti i componenti dall'imballo e posizzarli su una superficie di lavoro pulita | Consultare tutte le istruzioni di montaggio | Assemblare tutti i componenti secondo le istruzioni contenute nel manuale. Non saltare nessuna fase.

Leia as diretrizes de cuidados e segurança que constam da parte final deste manual | Verifique para se assegurar de que não há peças em falta ou danificadas ANTES de começar a preparar a montagem | Retire todas as peças da embalagem e espalhe-as numa superfície de trabalho limpa | Reveja todas as instruções de montagem | Monte todas as peças de acordo com as instruções do manual. Não salte quaisquer passos.

REQUIRED TOOLS | OUTILS EXIGÉS | HERRAMIENTAS NECESARIAS | BENÖTIGTE WERKZEUGE | BENODIGD GEREEDSCHAP | ATTREZZATURA OCCORRENTE | FERRAMENTAS NECESSÁRIAS

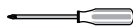
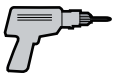

SPATULA | SPATULE | ESPÁTULA | SPACHTEL | SPATEL | SPATOLA | ESPĀTULA

- Use spatula (part "SG8") for easier insertion of panel into profile.
- Utilisez la spatule (partie "SG8") pour une meilleure insertion du panneau dans le profil.
- Utilice una espátula (pieza "SG8") para una mejor inserción del panel en el perfil.
- Benutzen Sie den Spachtel (Bezeichnung "SG8"), um die Platten leichter in die Nut einführen zu können.
- Gebruik spatel (onderdeel SG8) voor het gemakkelijk invoeren van het paneel in het profiel.
- Utilizzare la spatola (parte SG8) per inserire il pannello più facilmente nel profilo.
- Utilize uma espátula (peça "SG8") para facilitar a inserção do painel no perfil.

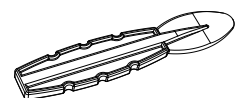











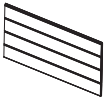

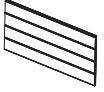

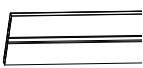

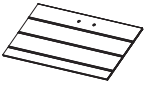







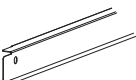
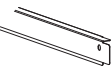

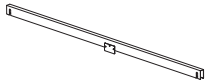



SG8 x1

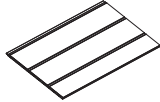
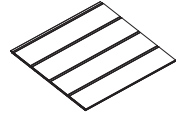
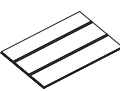

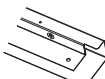

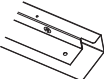
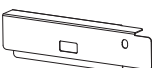
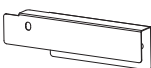







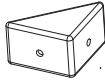





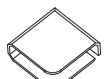

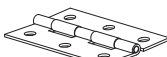
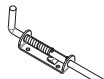

ASSEMBLY REQUIRES TWO PEOPLE | LE MONTAGE DOIT ÊTRE EFFECTUÉ PAR DEUX PERSONNES | SE NECESITAN DOS PERSONAS PARA ARMARLO | ZWEI PERSONEN ZUR MONTAGE NOTWENDIG | MONTAGE VEREIST TWEE PERSONEN | L'ASSEMBLAGGIO RICHIEDE DUE PERSONE | A MONTAGEM EXIGE DUAS PESSOAS

PARTS LIST

R1 	R2 	R3 	R4 	R5 	R6 
1 pc	1 pc	2 pc	1 pc	1 pc	1 pc
R7 	R8 	R9 	R12 	R13 	R14 
1 pc	1 pc	1 pc	1 pc	1 pc	1 pc
R15 	R16 	R17 	R18 	R19 	R20 
2 pc	1 pc	2 pc	2 pc	2 pc	1 pc
R21 	R22 	R23 	R24 	R25 	R26 
1 pc	1 pc	1 pc	1 pc	1 pc	1 pc
R27 	R28 	R29 	R30 	R39 	R40 
1 pc	1 pc	1 pc	4 pc	1 pc	1 pc
R41 	R31 	R32 	R33 	R34 	R35 
1 pc	1 pc	1 pc	1 pc	1 pc	1 pc
R36 	R37 	R38 			
1 pc	1 pc	2 pc			

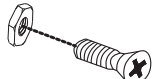
PARTS LIST

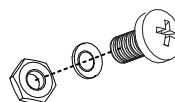
SG21 	SG22 	SG26 	Drill 	TOA 	SG6 
4 pc	4 pc	4 pc	1 pc	2 pc	4 pc
SG7-1 	SG7-2 	SG5-1 	SG5-2 	FP1 	DC 
1 pc	1 pc	4 pc	4 pc	6 pc	2 pc
LOCK-1 	LOCK-2 	LOCK-3 	SG8 	Z1 	Z2 
1 pc	1 pc	1 pc	1 pc	129 pc	58 pc
Z3 	CZ415 	RF6 	RF8 	RF7 	
21 pc	2 pc	4 pc	2 pc	2 pc	

1. Please ensure that all accessories are complete before starting the installation.
2. Due to the variety of accessories, many accessories may be glued together, please check carefully.
3. If any accessories are missing or damaged, please contact the seller immediately.

E-Mail: Patiofurniturestserviceteam@outlook.com

FLOOR ASSEMBLY

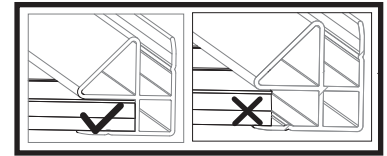

● Fully fit the panel inside the profile

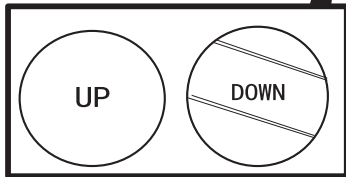
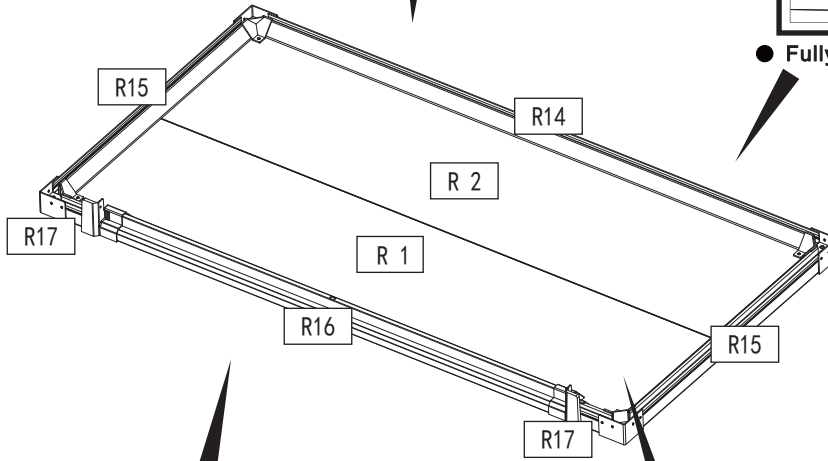

The crease line of the floor must be underneath

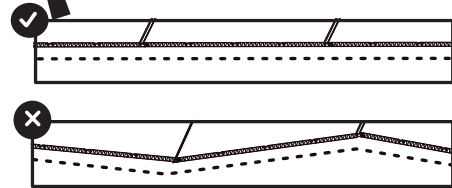

STEP 1

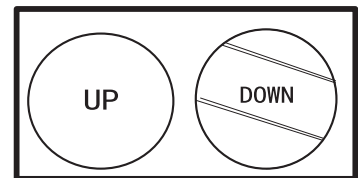
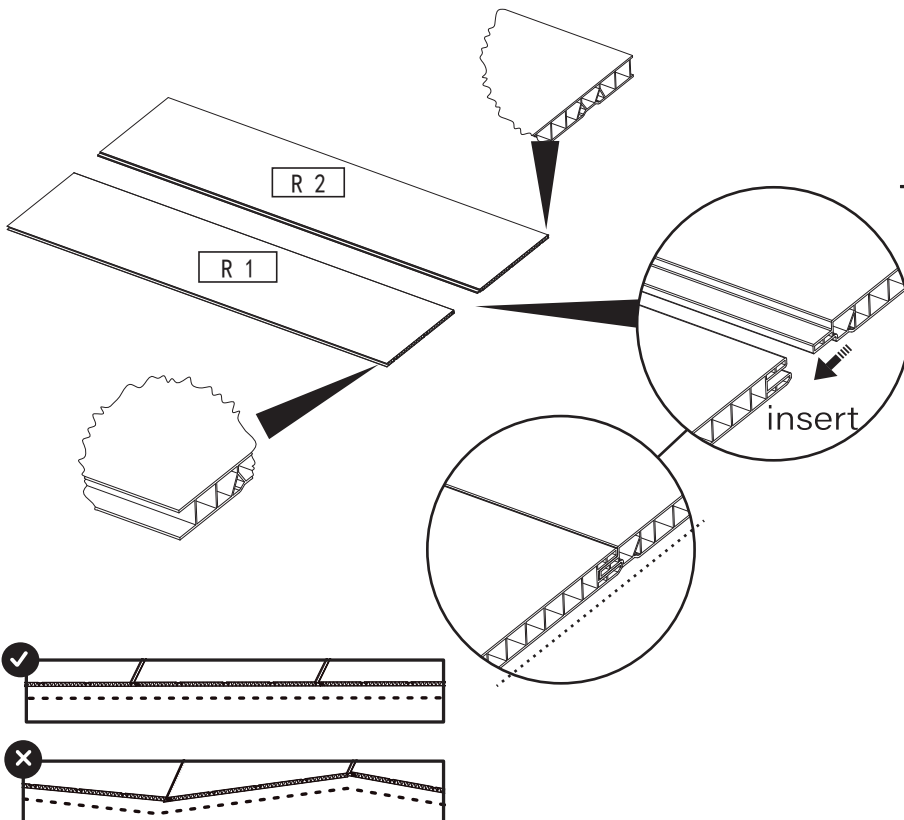

The crease line of the floor must be underneath

R 1	
	1 PC
R 2	
	1 PC

STEP 2

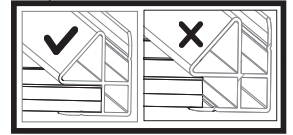

● Fully fit the panel inside the profile

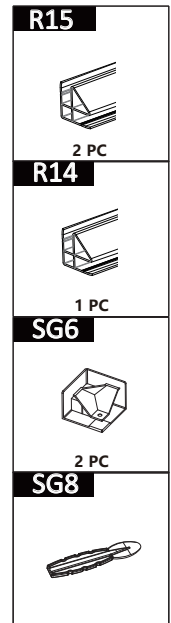
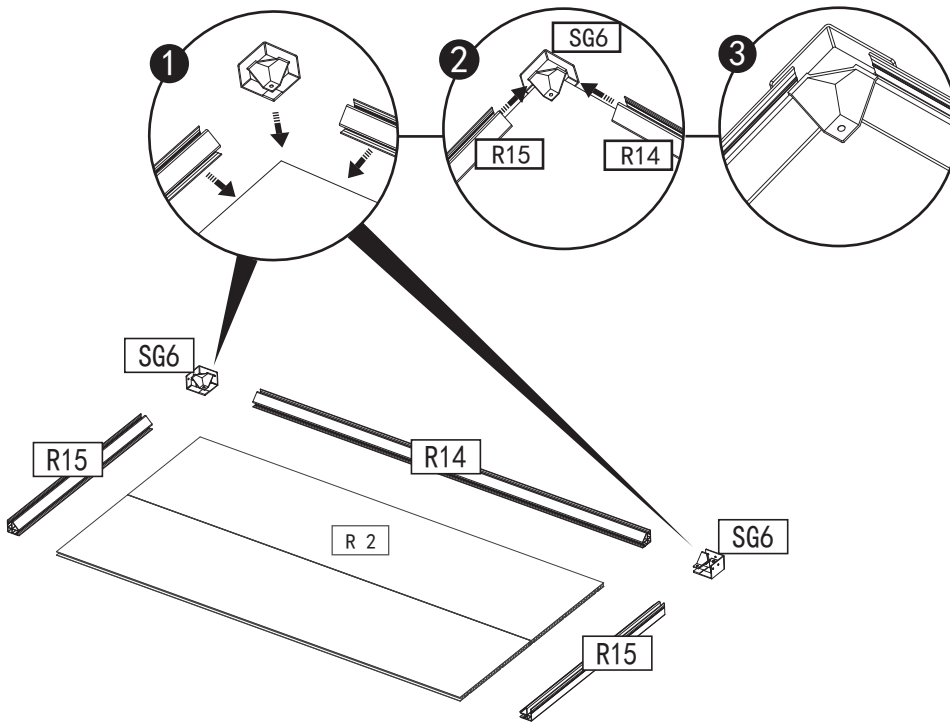

STEP 3

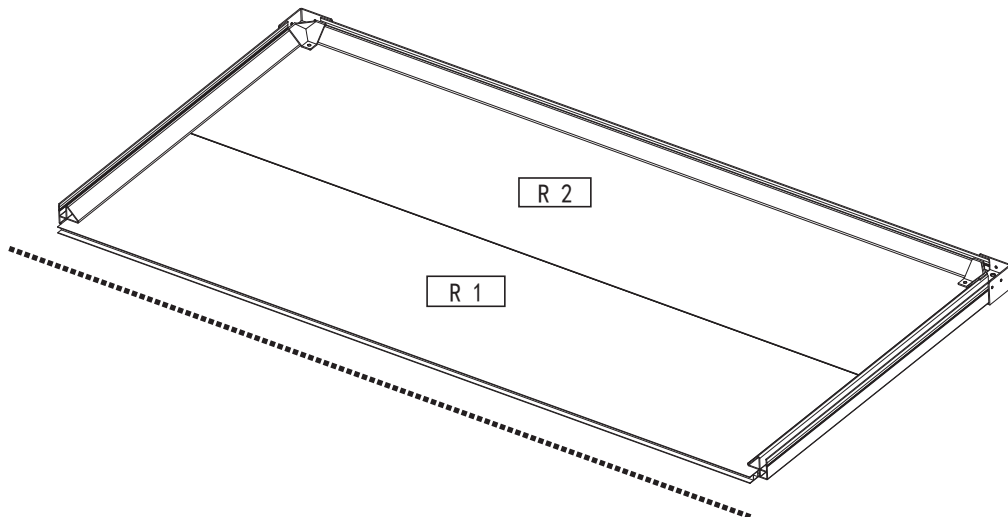

The floor boards must be straight

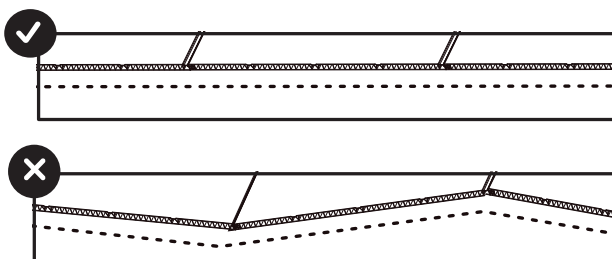

STEP4

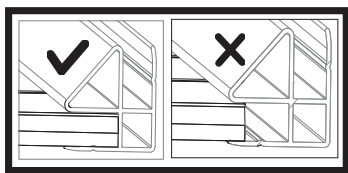

● Fully fit the panel inside the profile

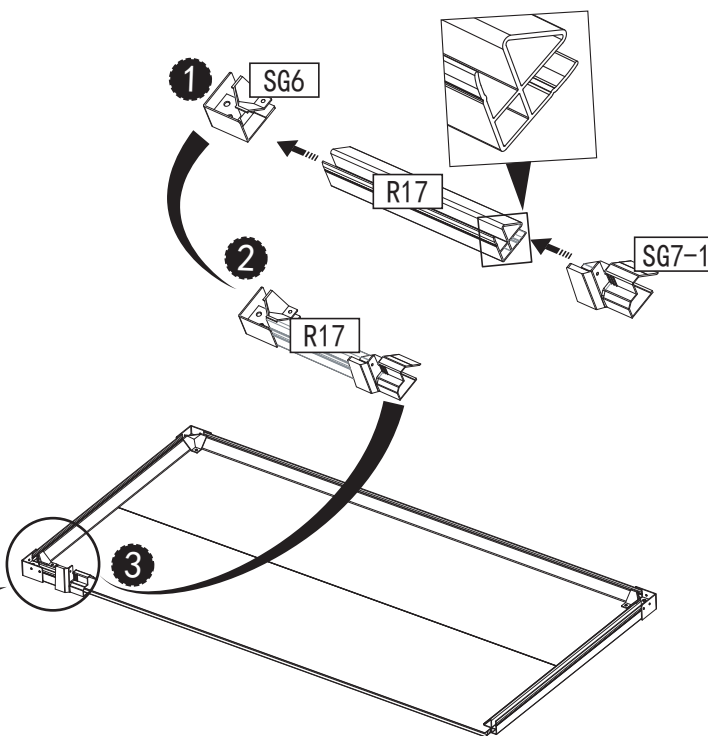
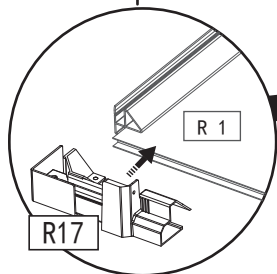
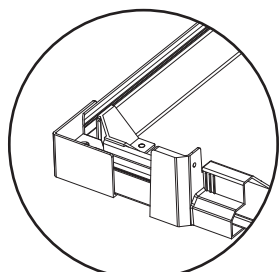

SG6



1 PC

R17



1 PC

SG7-1



1 PC

SG8



STEP5

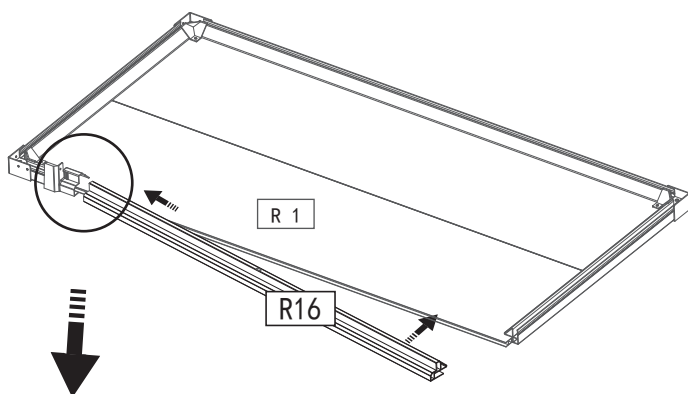

R16



1 PC

SG8



2 PC

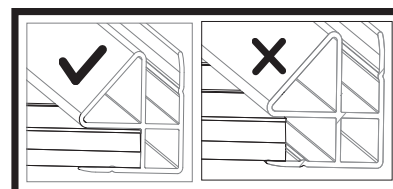
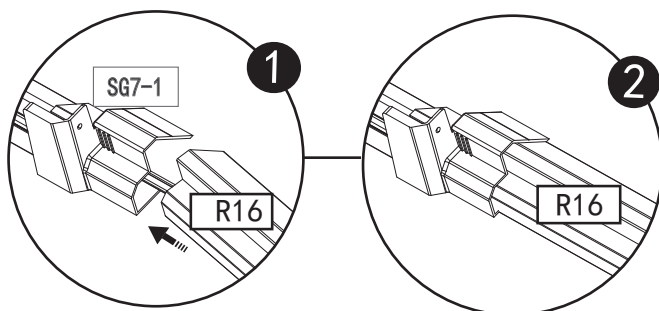

● Fully fit the panel inside the profile

STEP 6

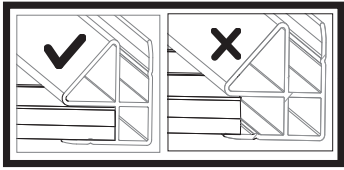

● Fully fit the panel inside the profile

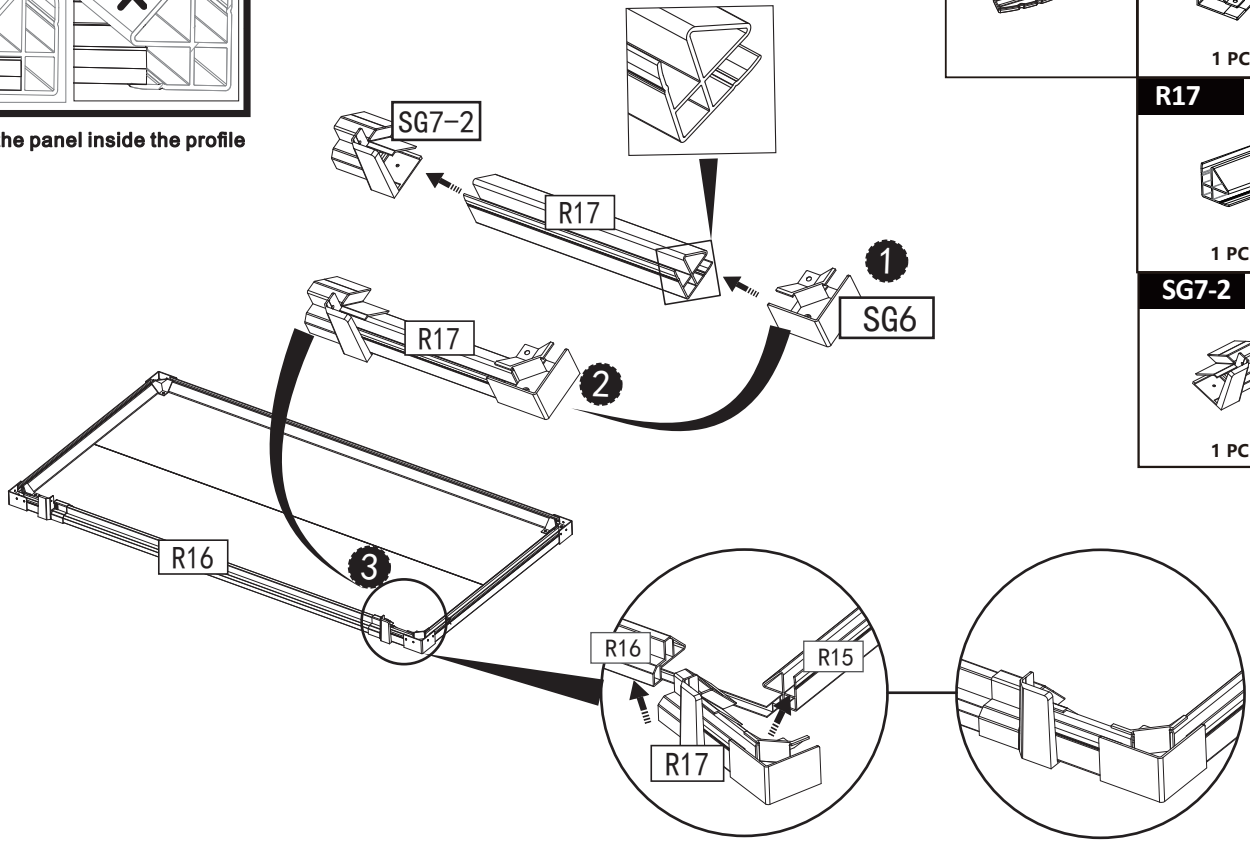

SG8	SG6
	1 PC
	R17
	1 PC
	SG7-2
	1 PC

STEP 7

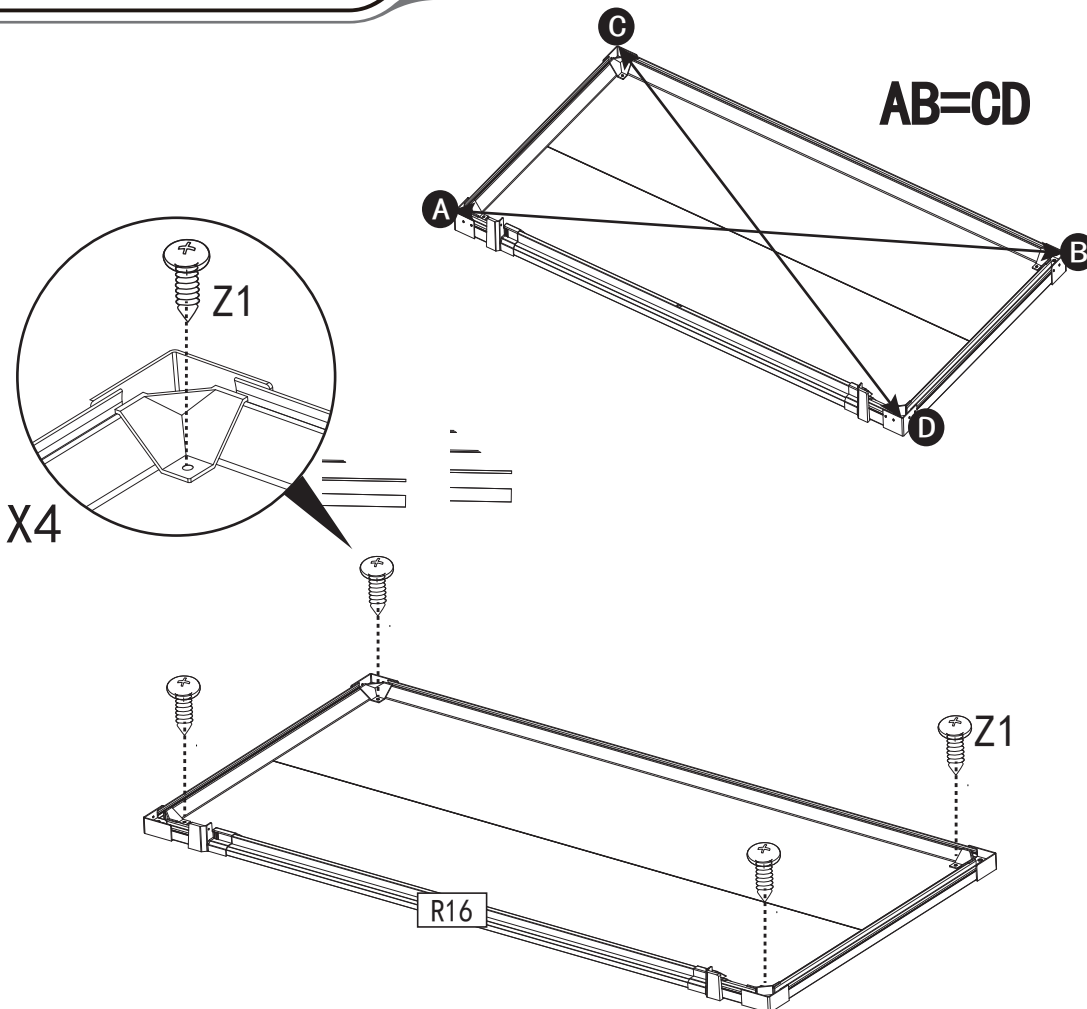

Z1
4 PC

X4

STEP 10

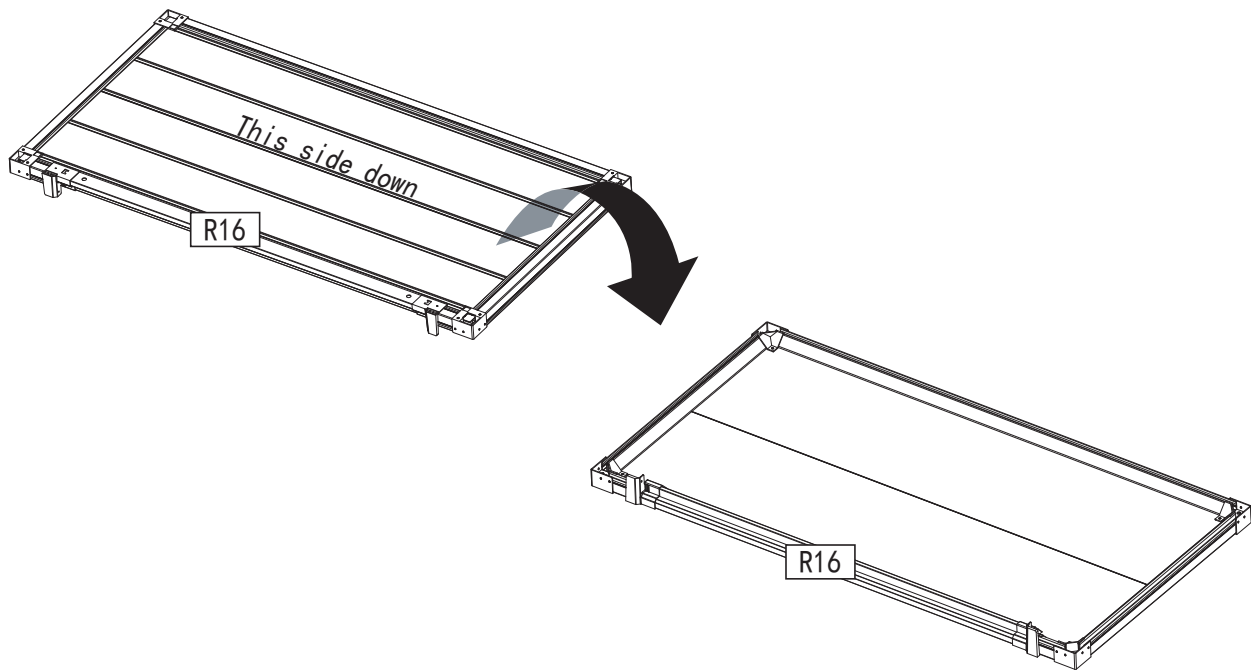

Wall Assembly

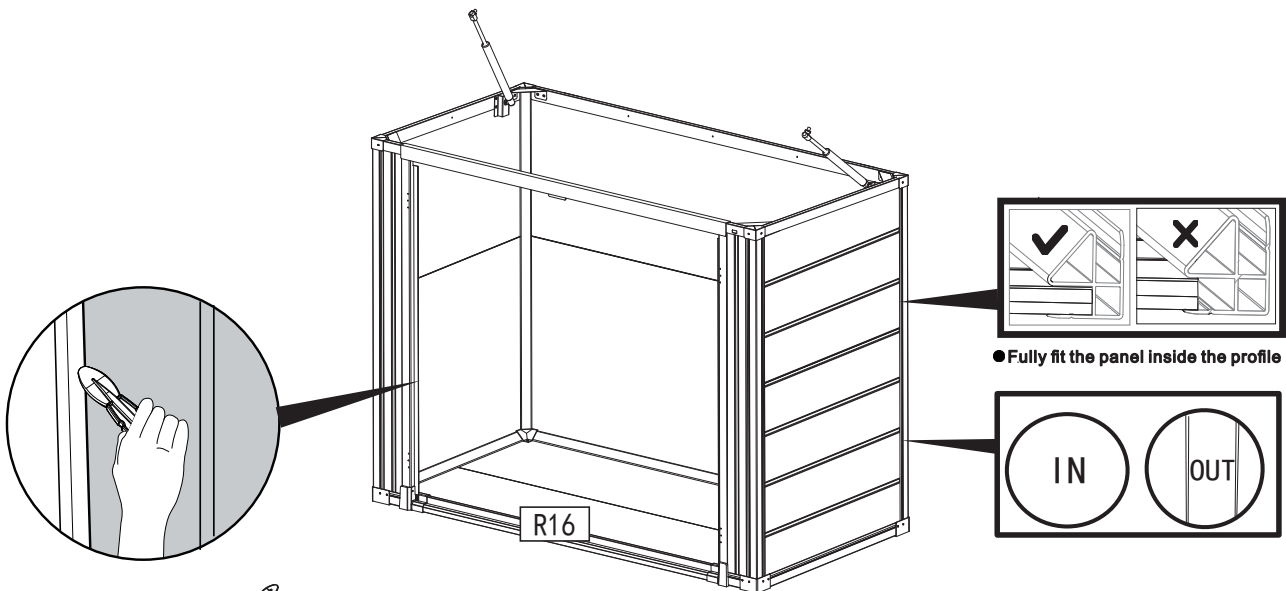

- Use spatula  (part "SG8") for easier insertion of panel into profile

- Fully fit the panel inside the profile

STEP11

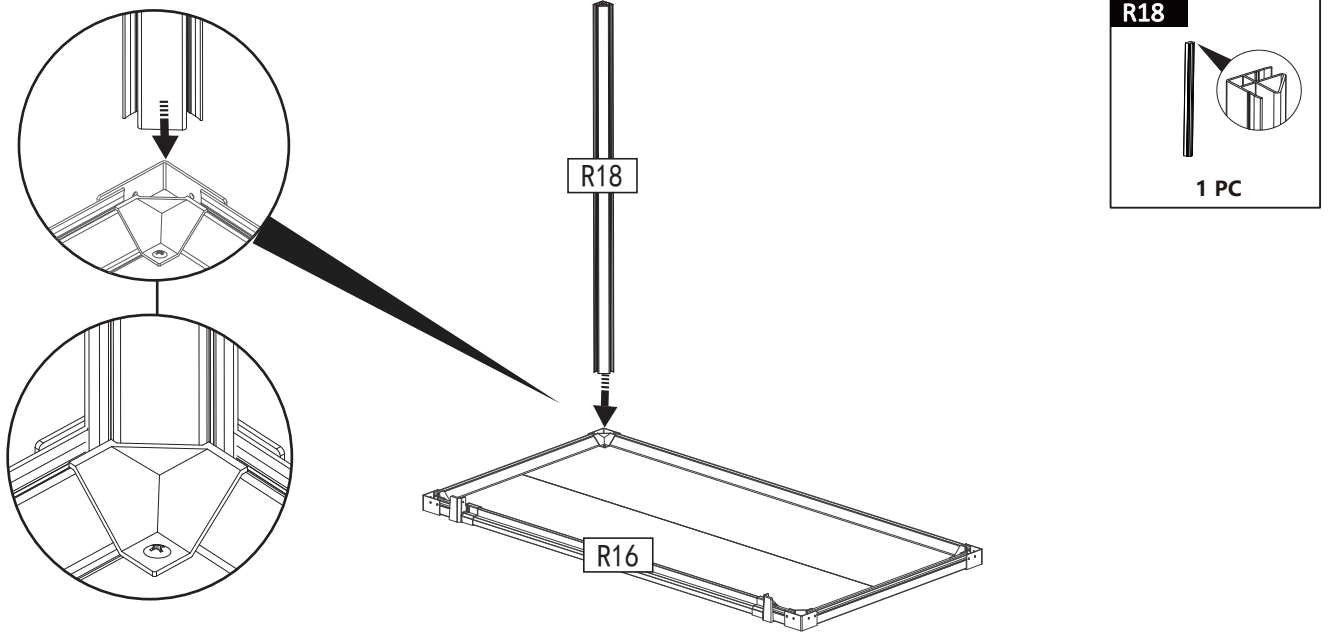

STEP12

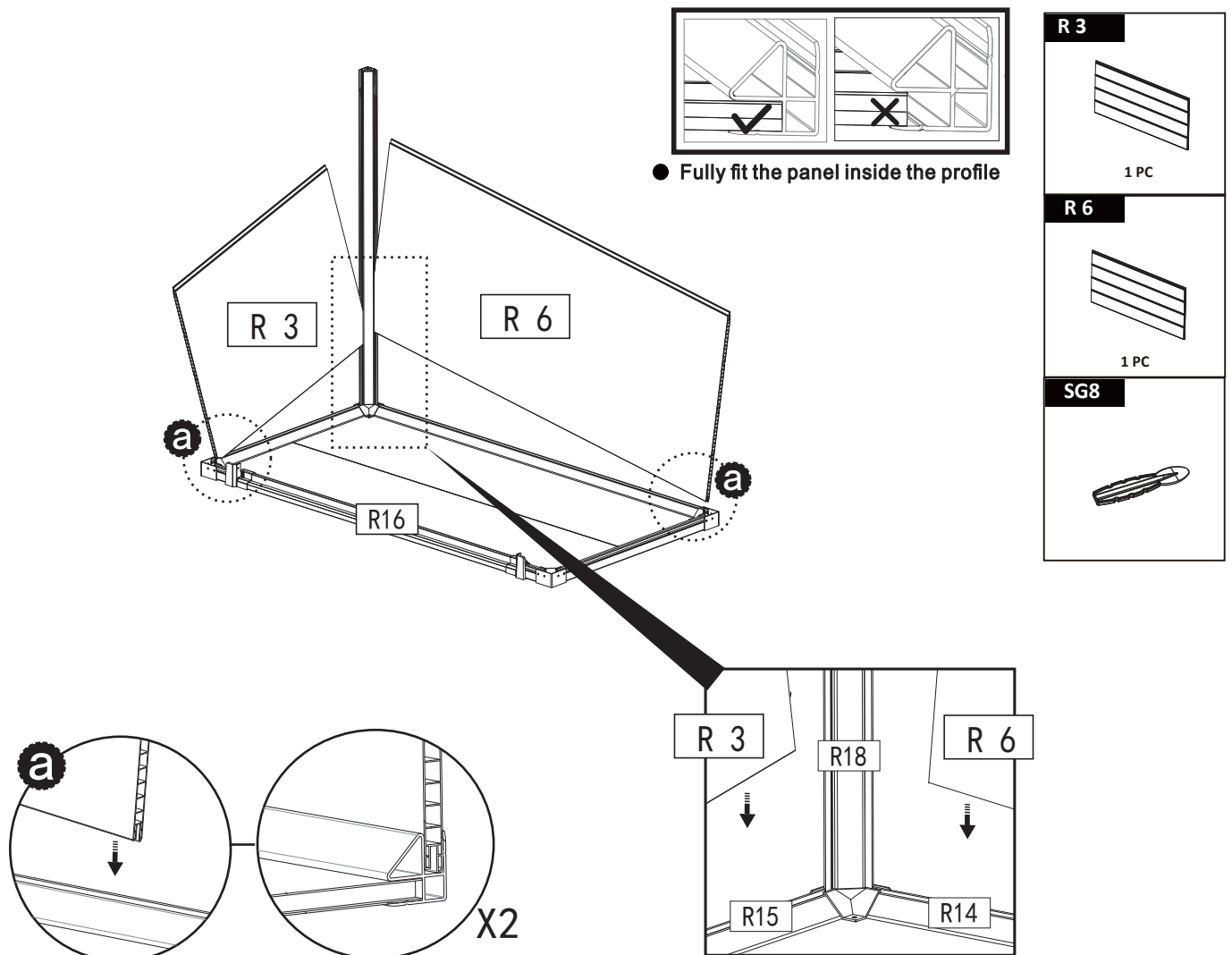

STEP 13

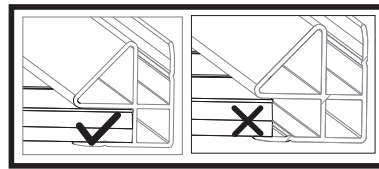
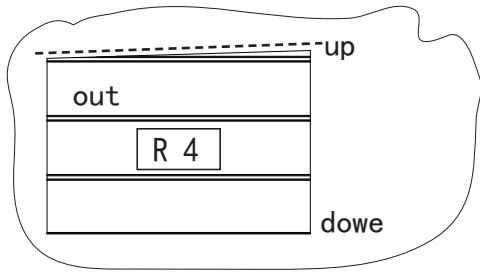

● Fully fit the panel inside the profile

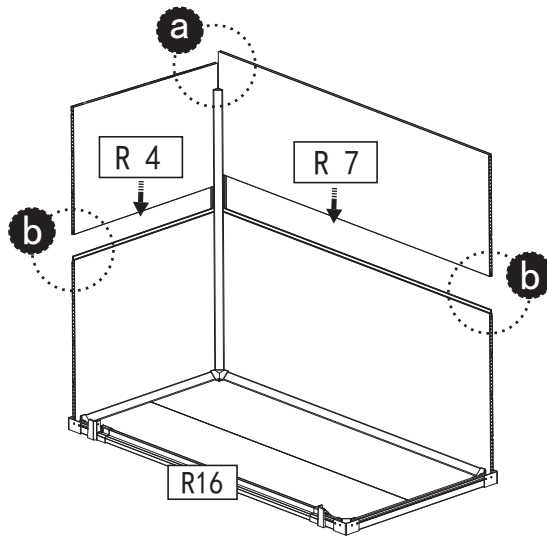
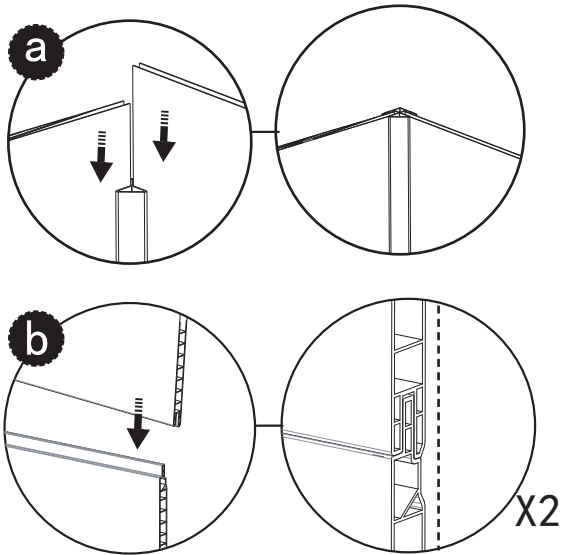
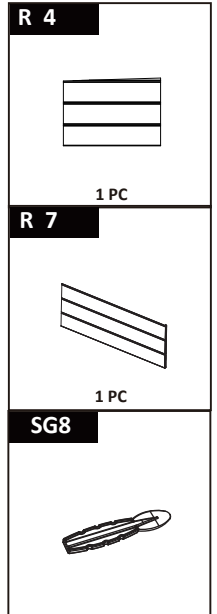

STEP 14

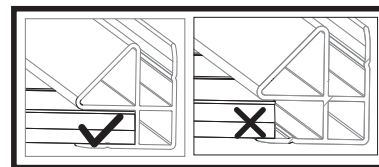

● Fully fit the panel inside the profile

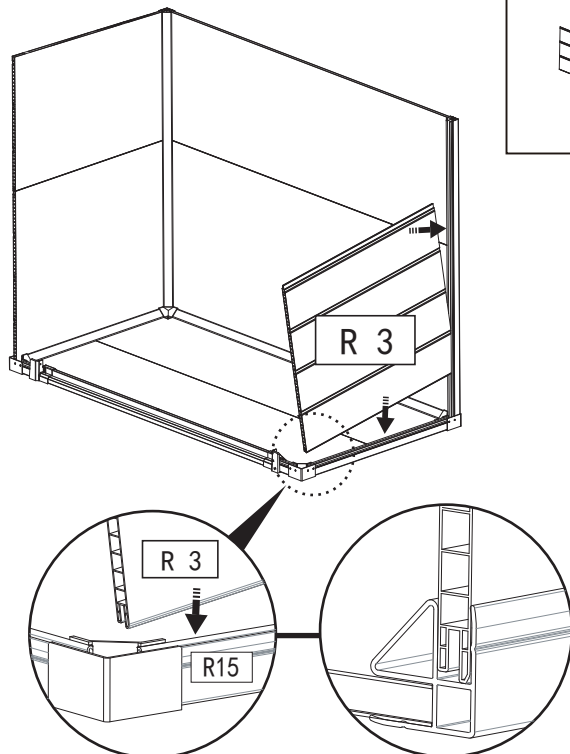
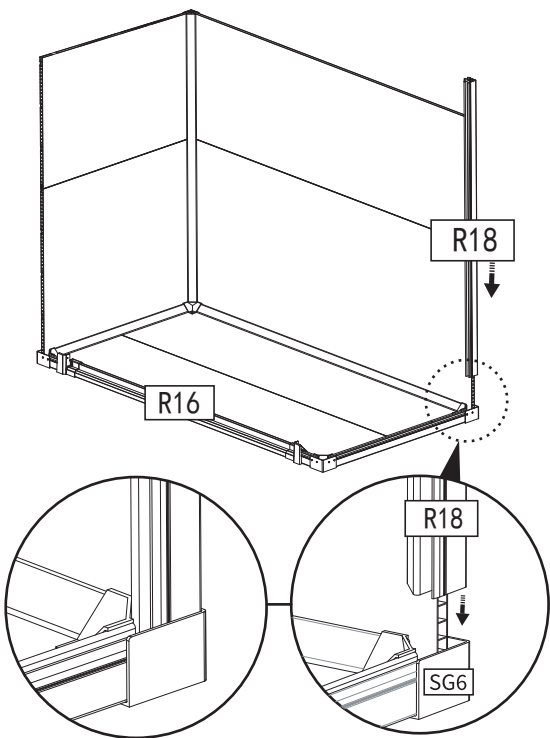
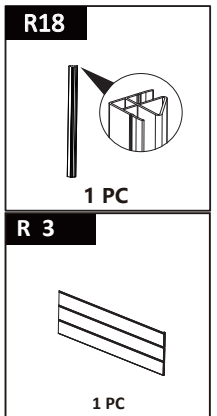

STEP 15

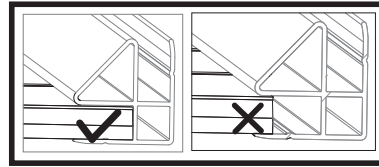
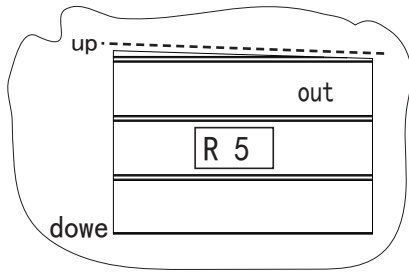

● Fully fit the panel inside the profile

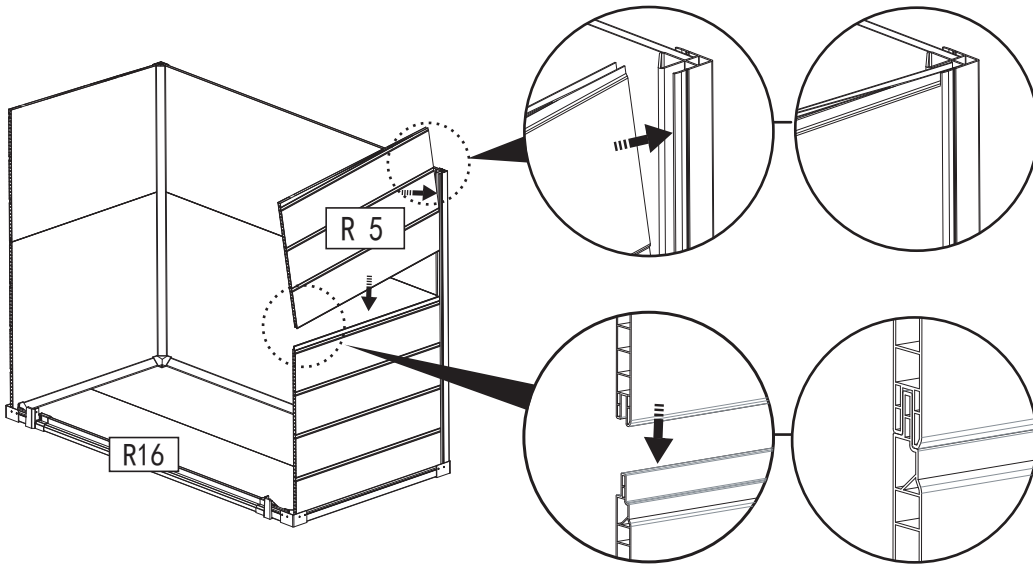
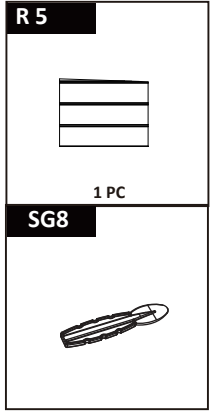

STEP 16

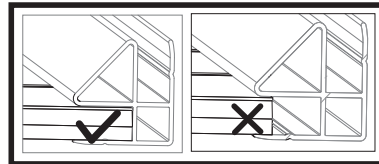

● Fully fit the panel inside the profile

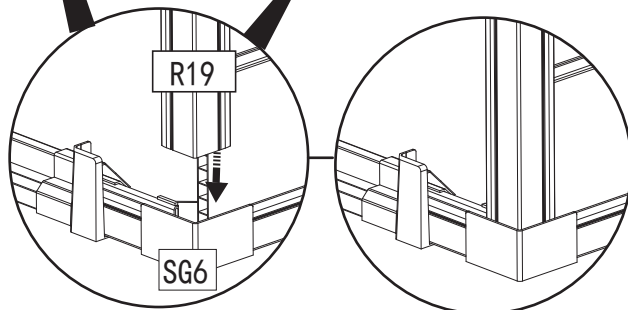
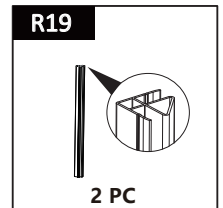
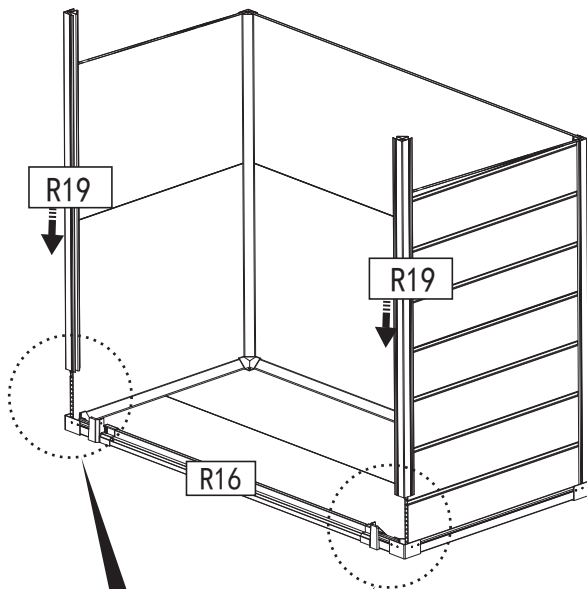

STEP17

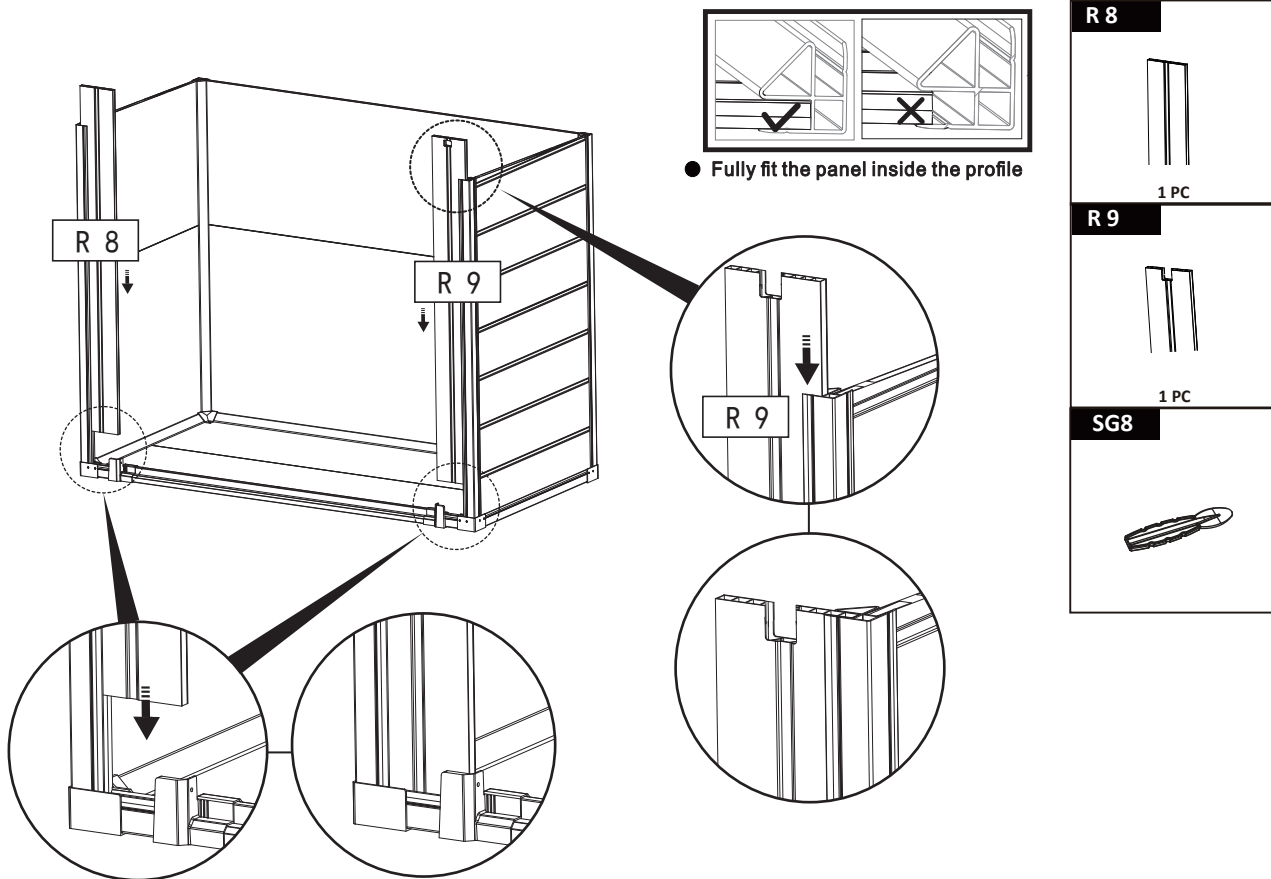

STEP18

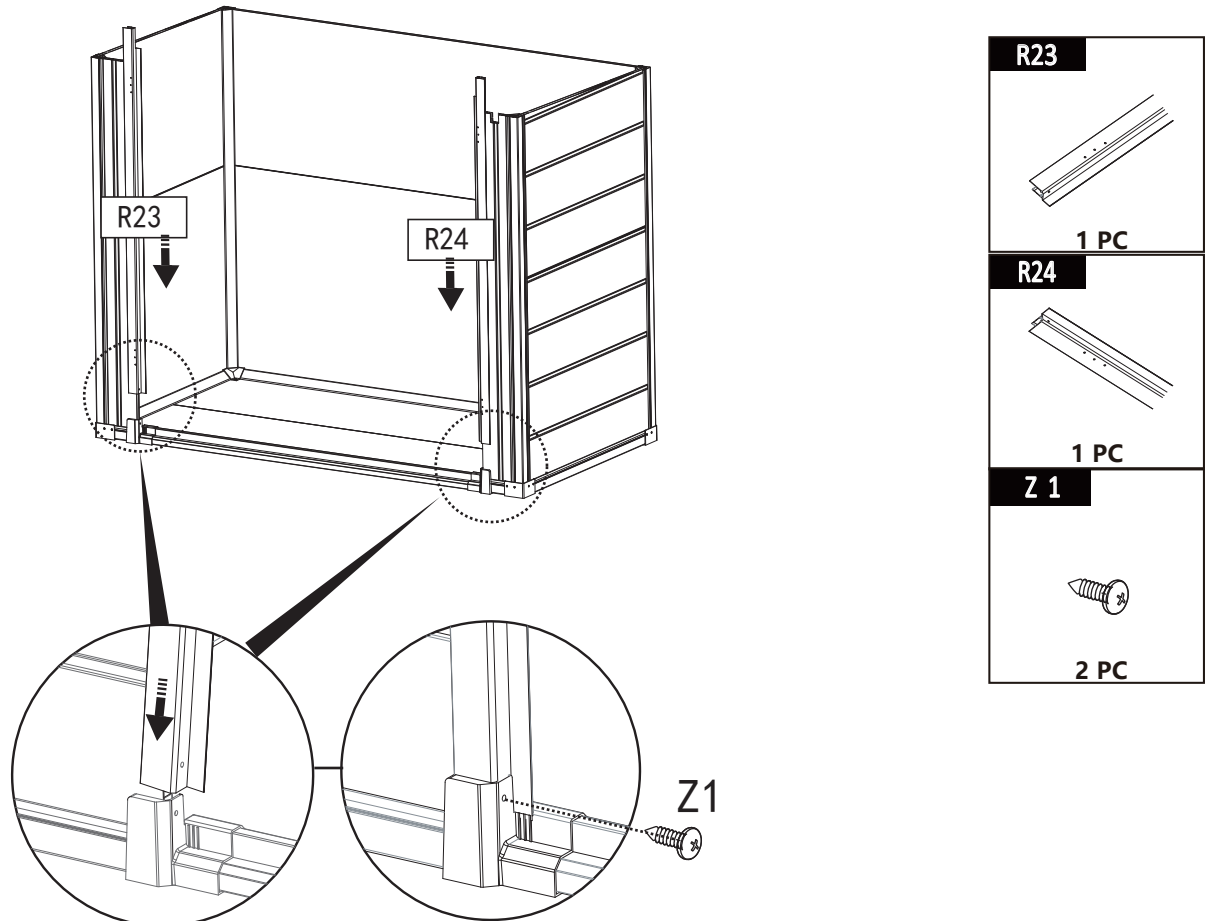

STEP19

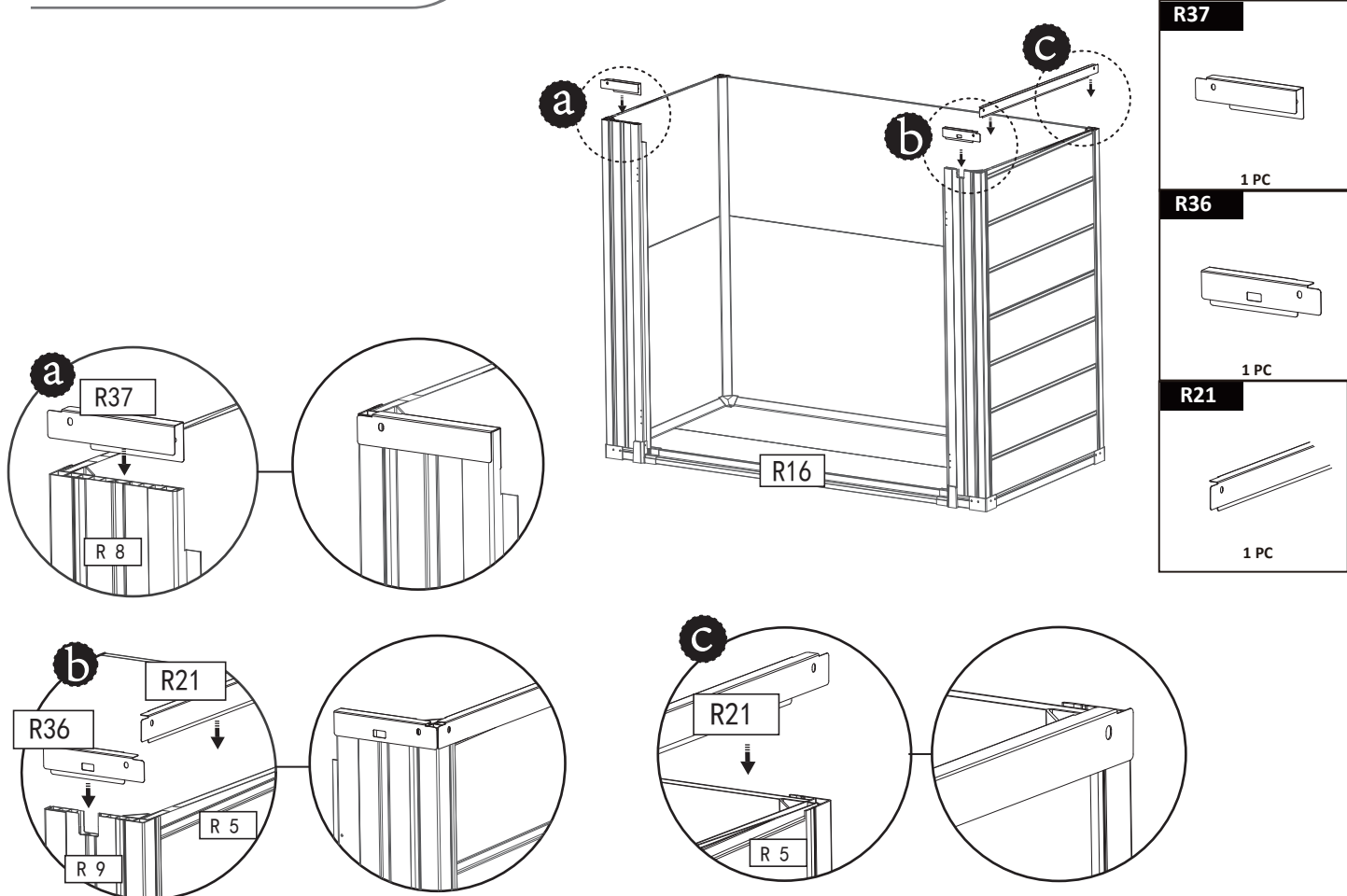

STEP20

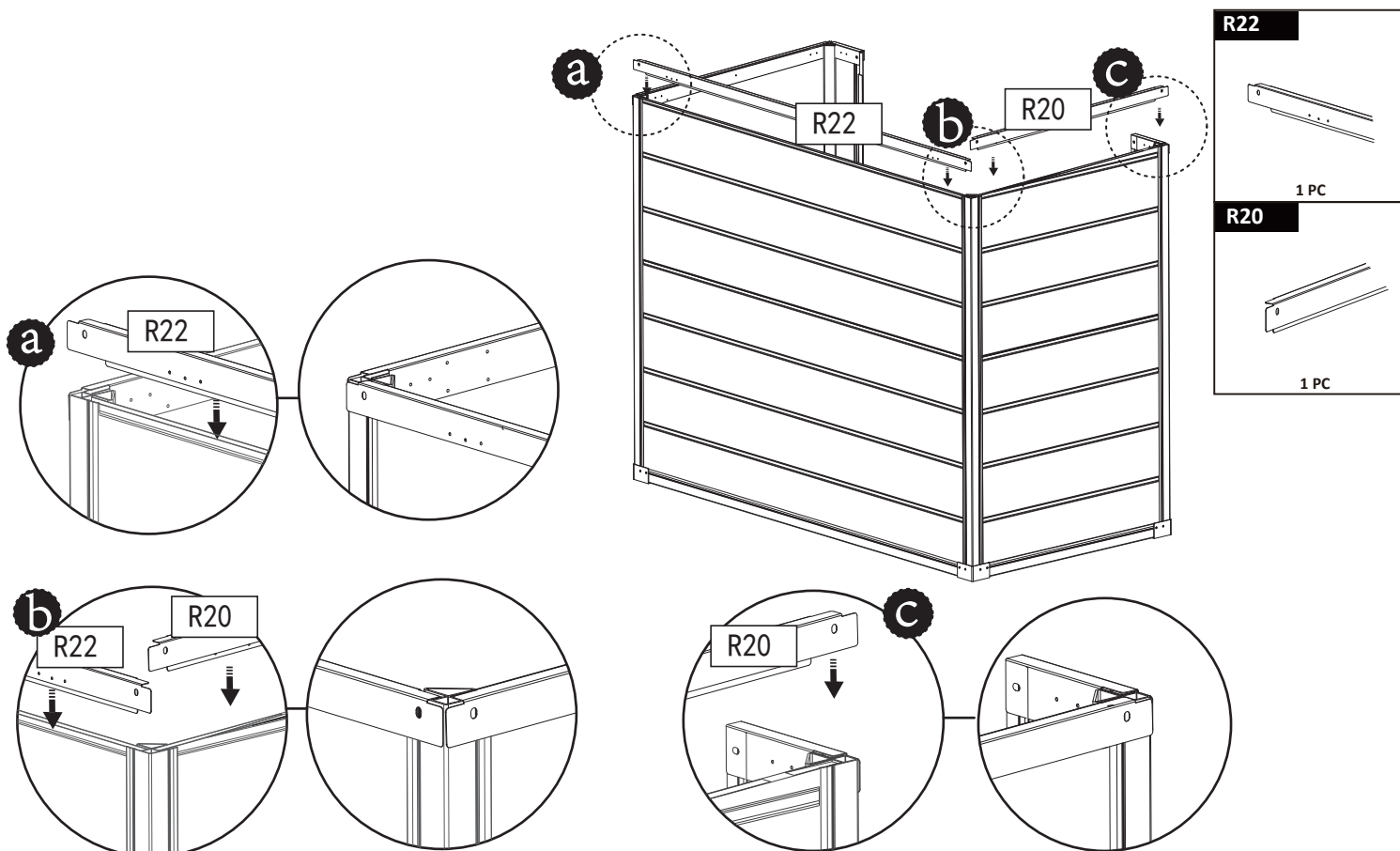

STEP21

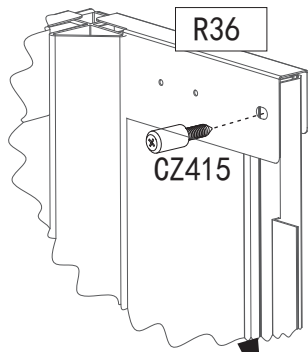

CZ415



2 PC

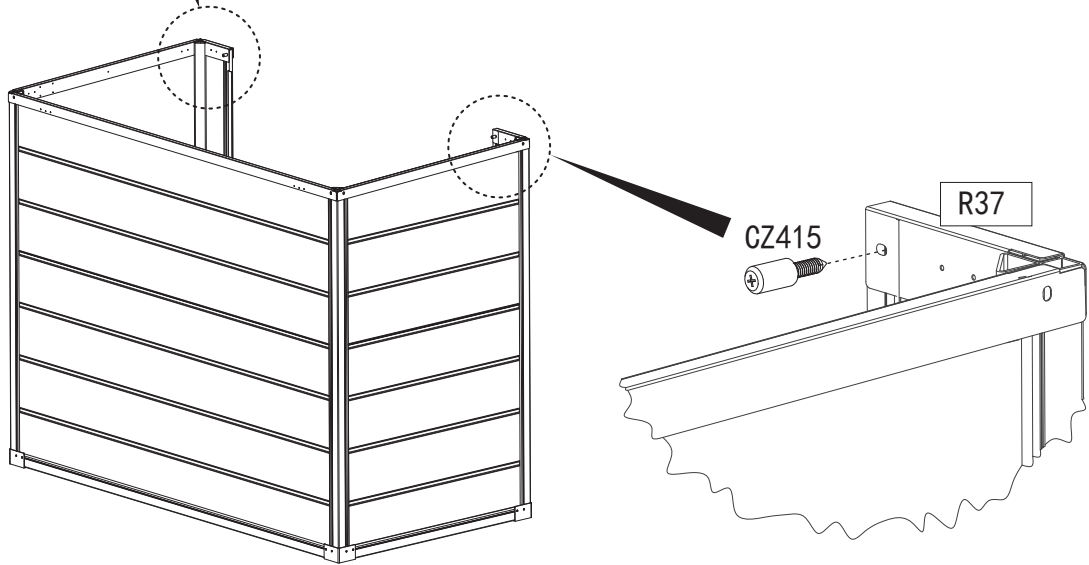

STEP22

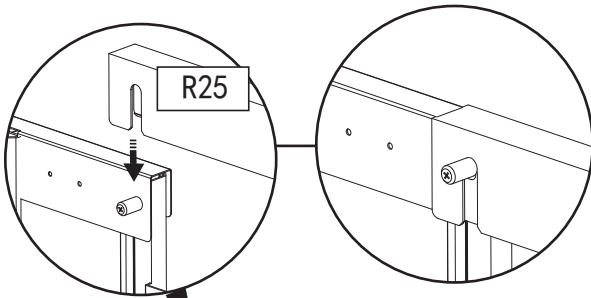

R25

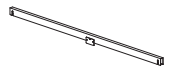

1 PC

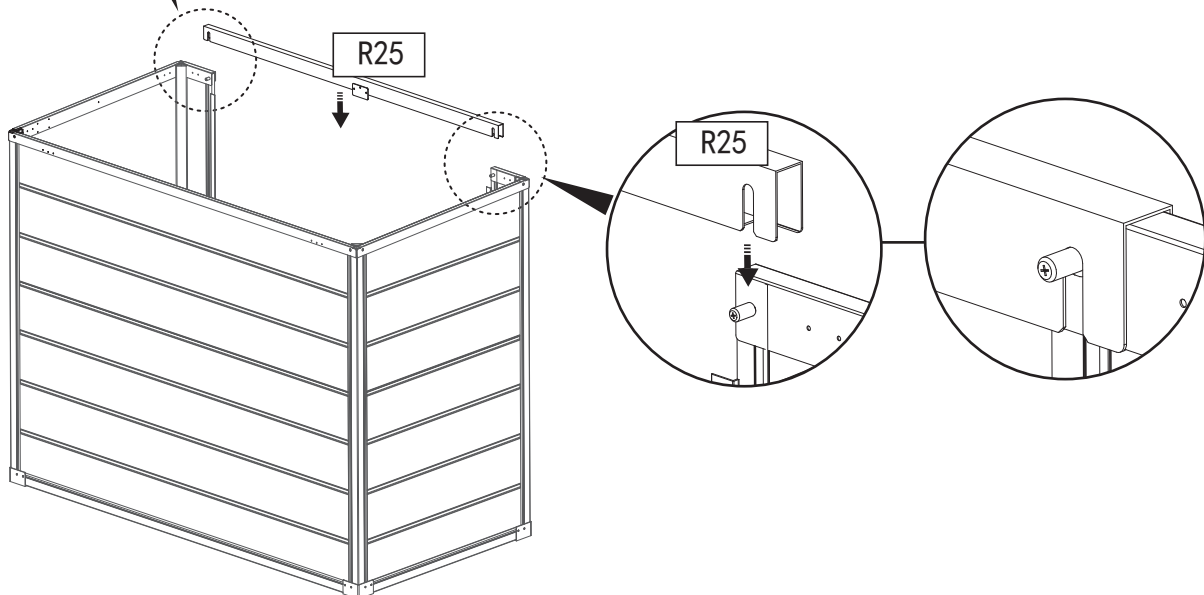

STEP23

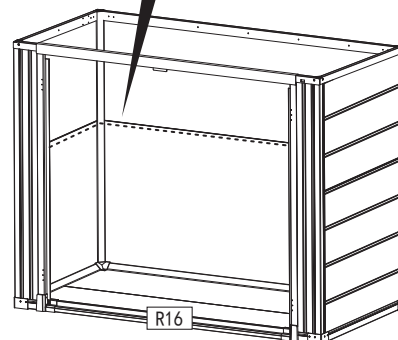
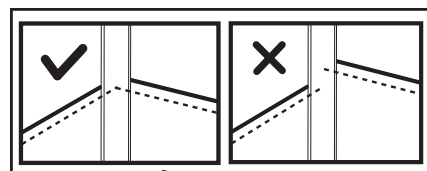
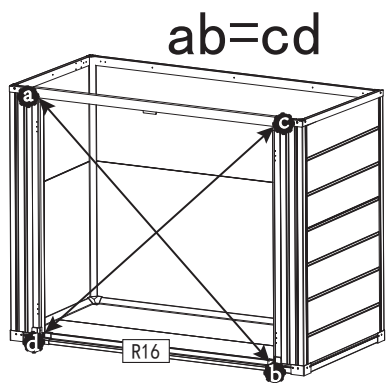

AB=CD

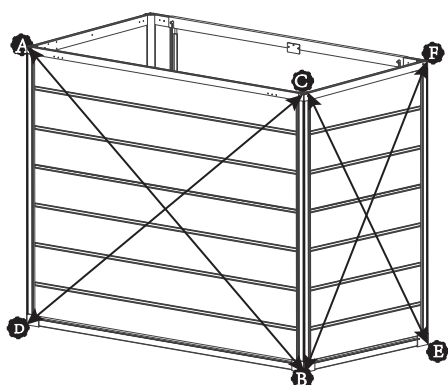

CE=FB

STEP24

Make sure everything is in place and turn the screws.

Z2



27 PC

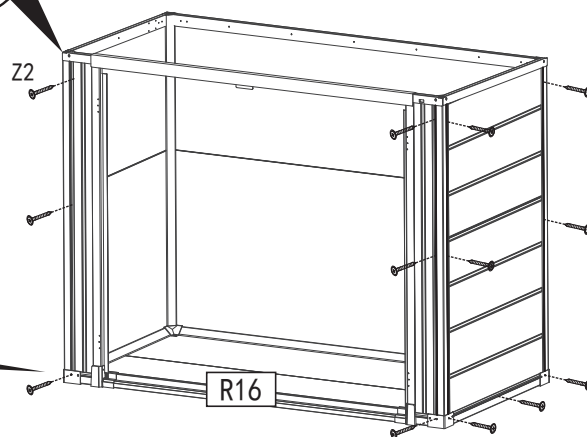
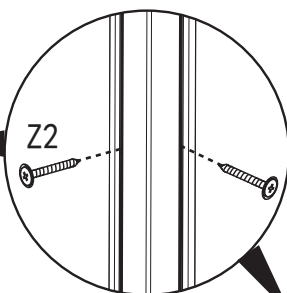
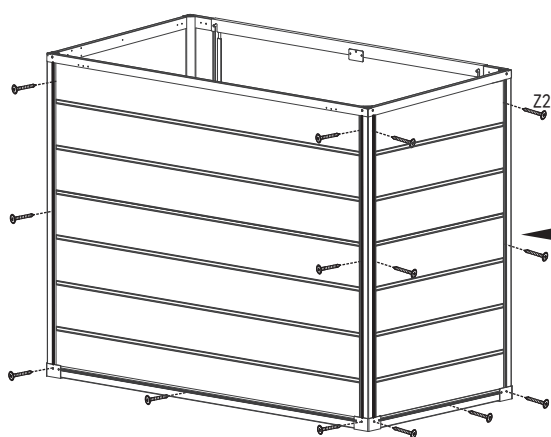
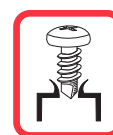

Caution:

Please use Drill to predrill a hole at depth 1mm before screw.



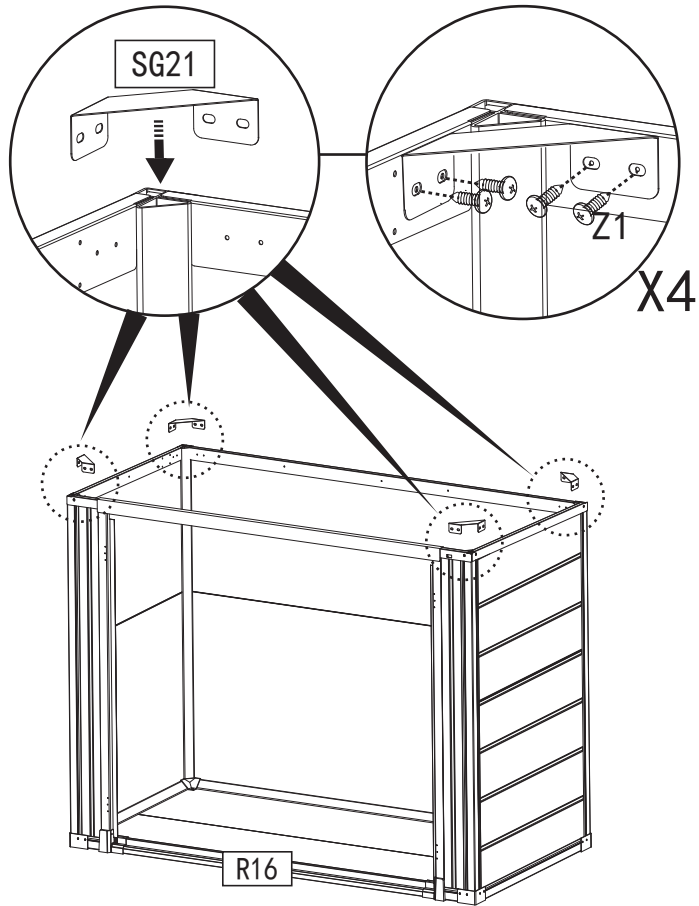

STEP25

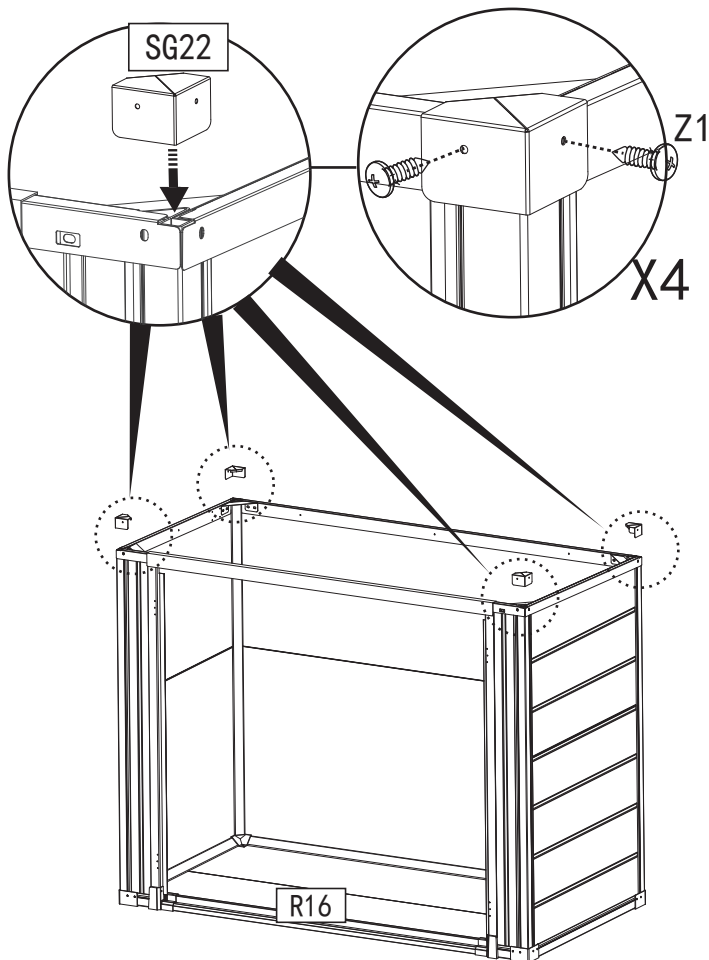

SG21

4 PC
Z 1

8 PC

STEP26

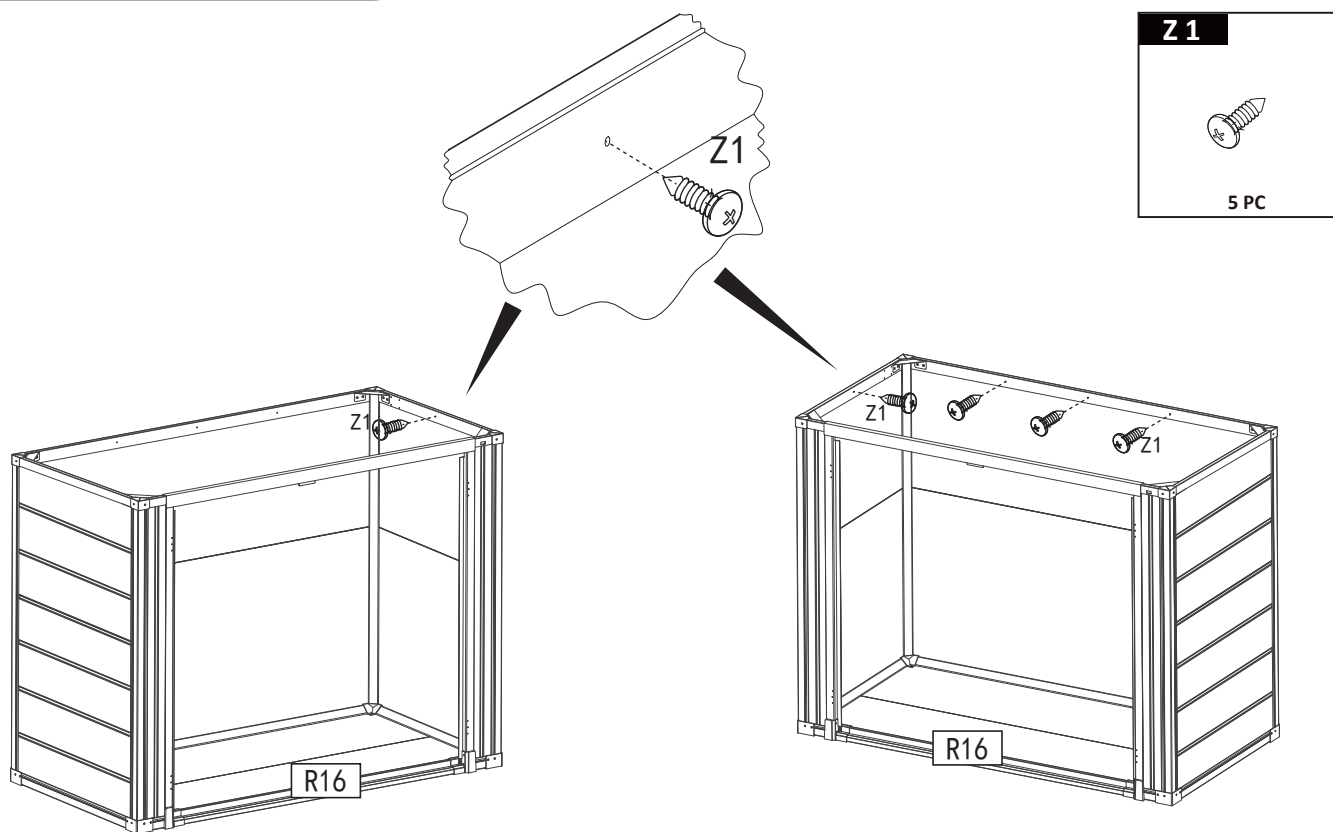

SG22

4 PC
Z 1

16 PC

STEP27

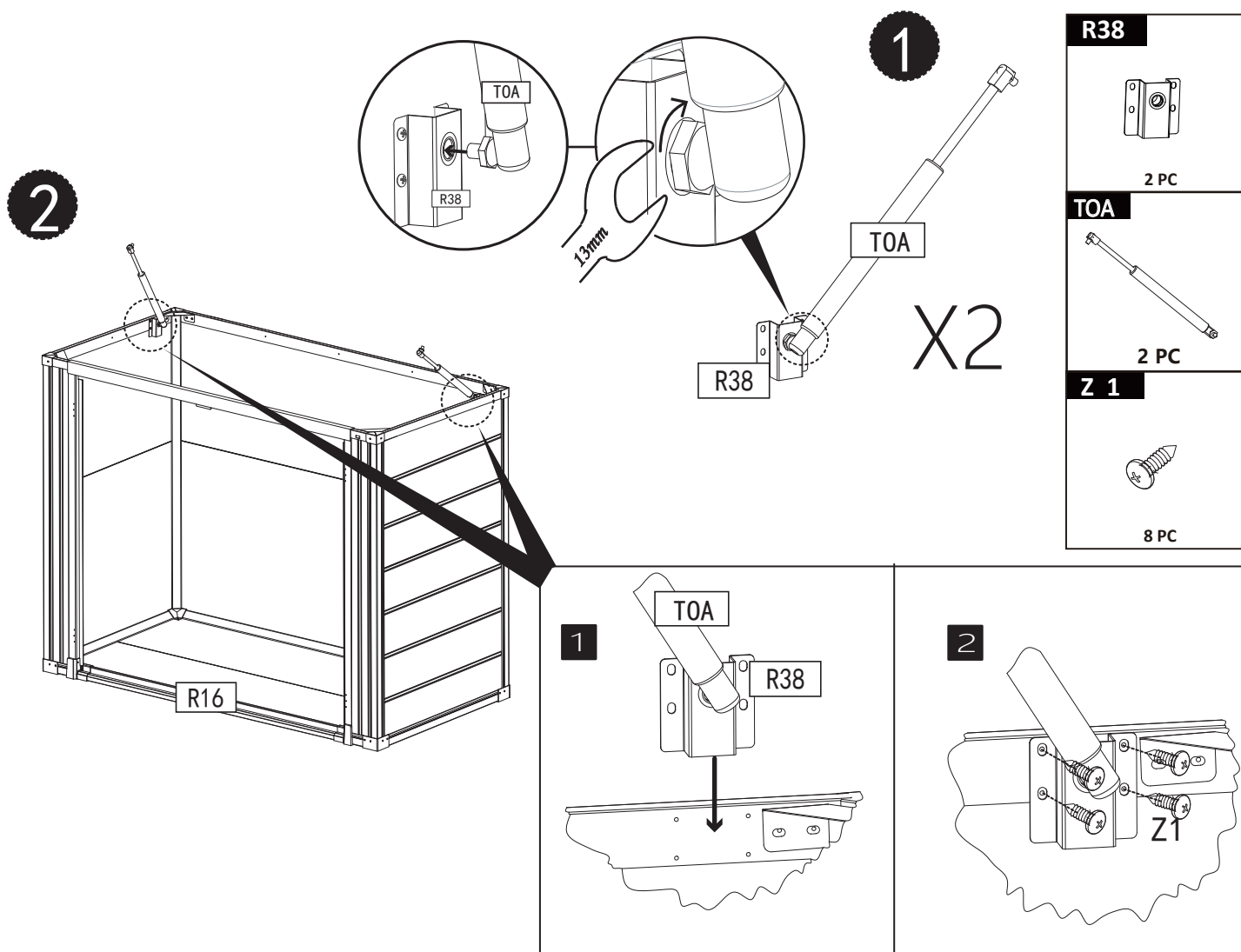

STEP28



ROOF PARTS

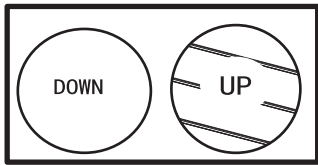
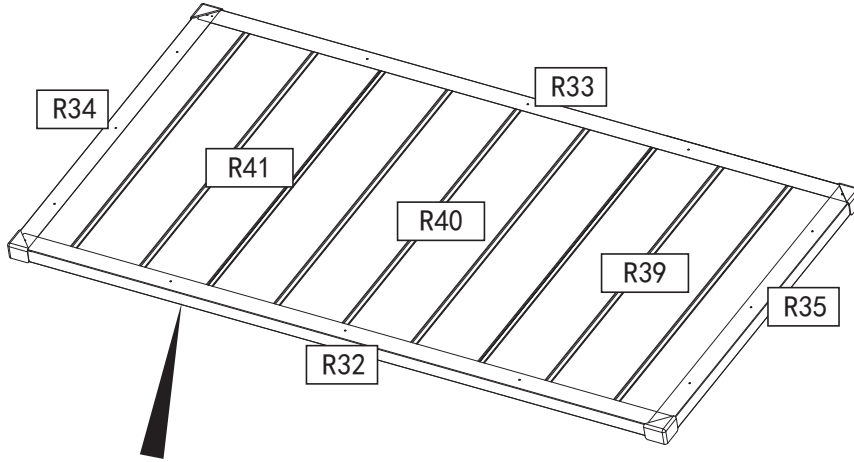

The stripes should be upwards

STEP29

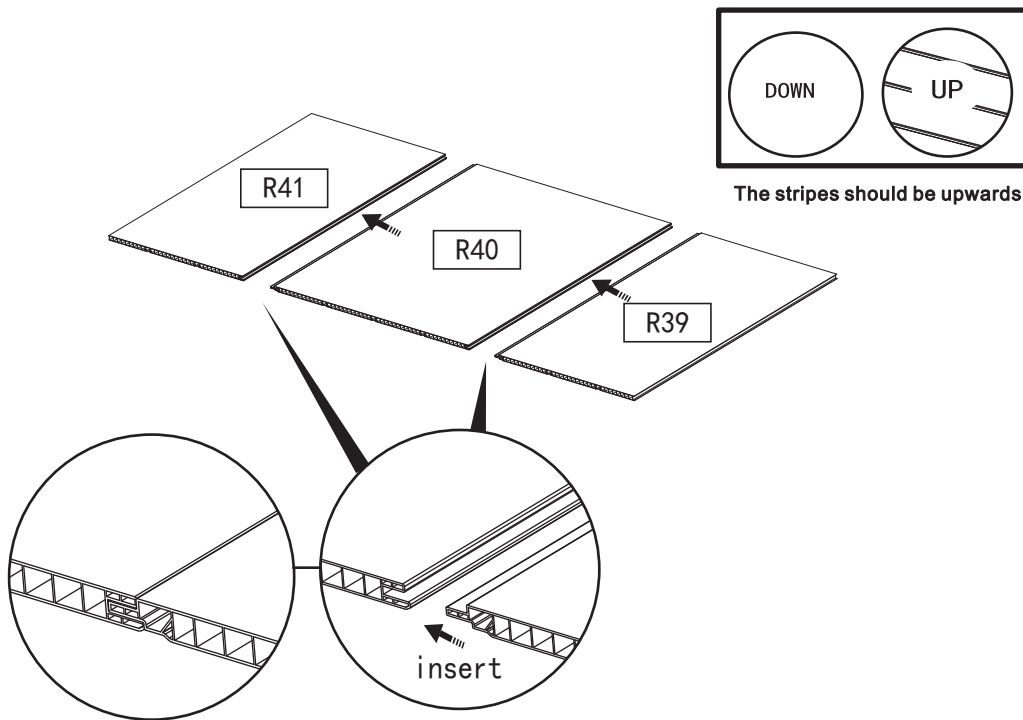

R40		1 PC
R41		1 PC
R39		
SG8		

STEP30

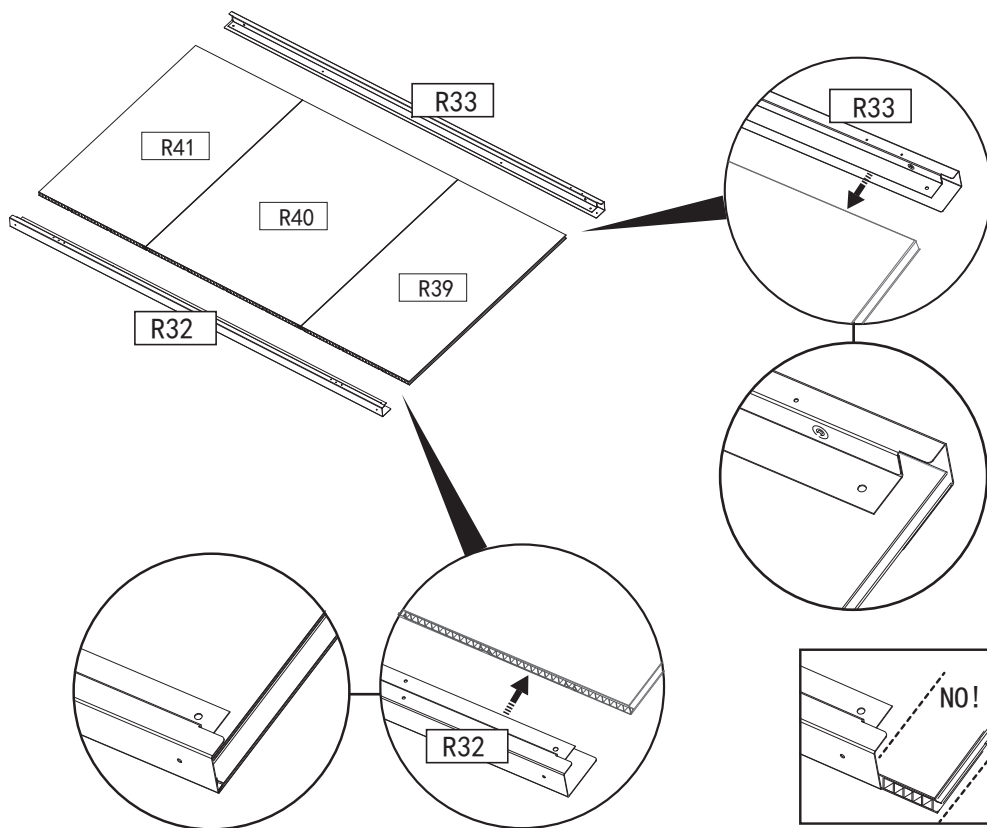

R33

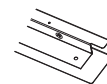

1 PC

R32



1 PC

SG8

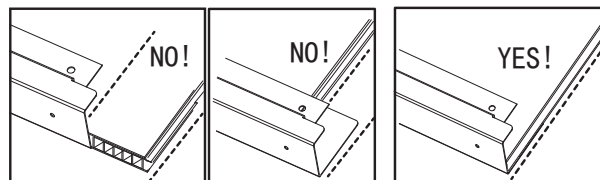

STEP31

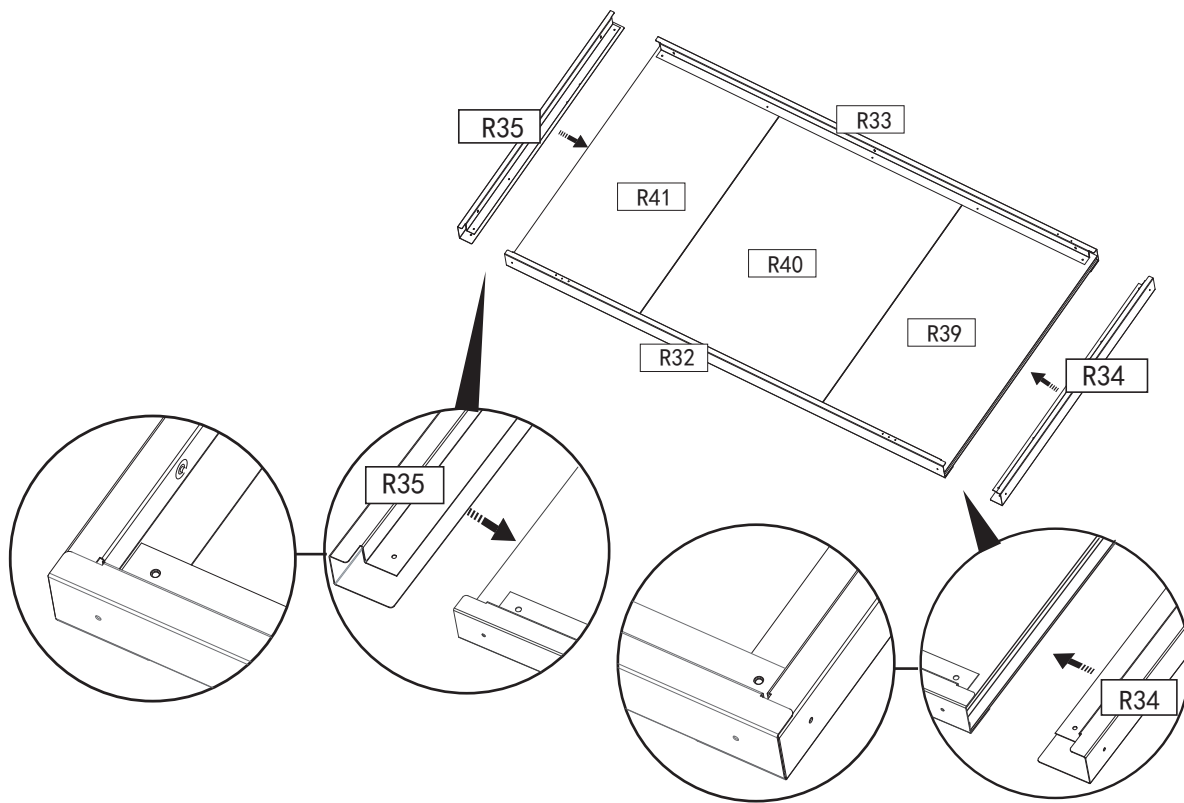

R35



1 PC

R34



1 PC

SG8

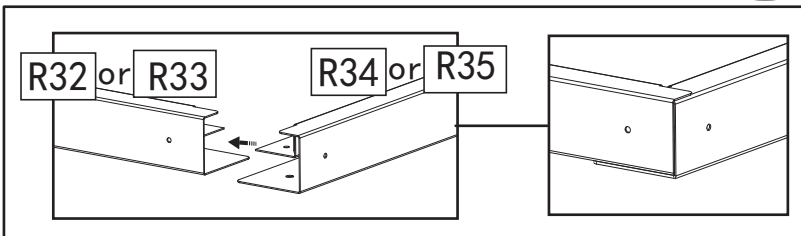

STEP32

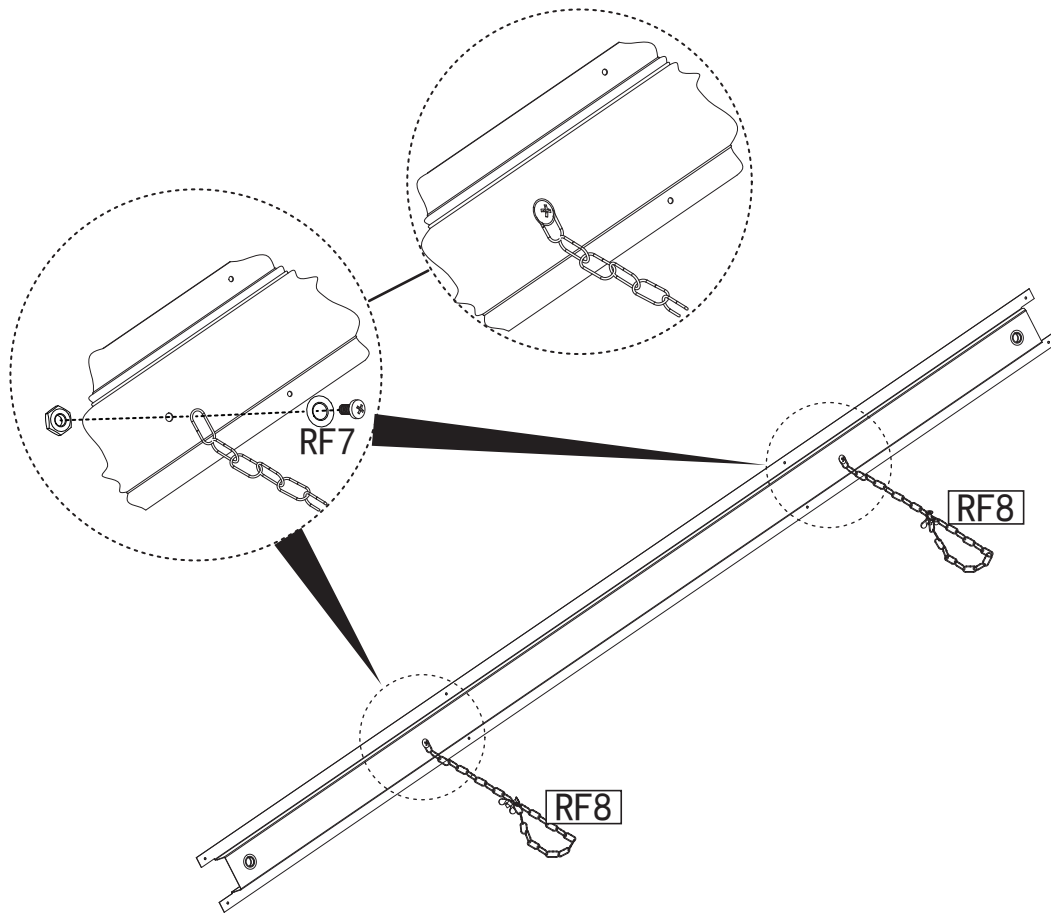

R31

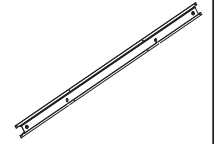

RF8



2 PC

RF7

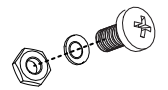

2 PC

STEP33

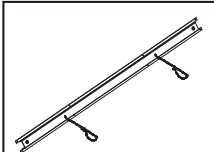
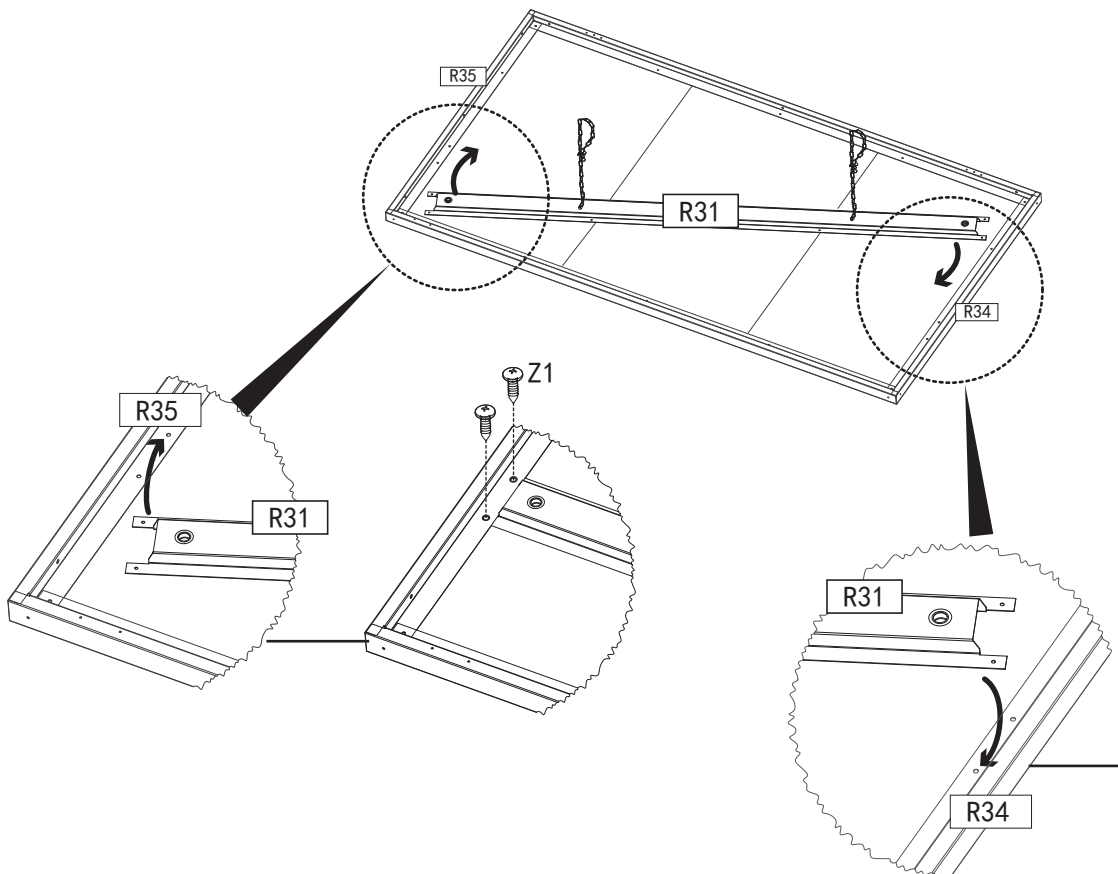

R31 + F8

Z1



4 PC

STEP34

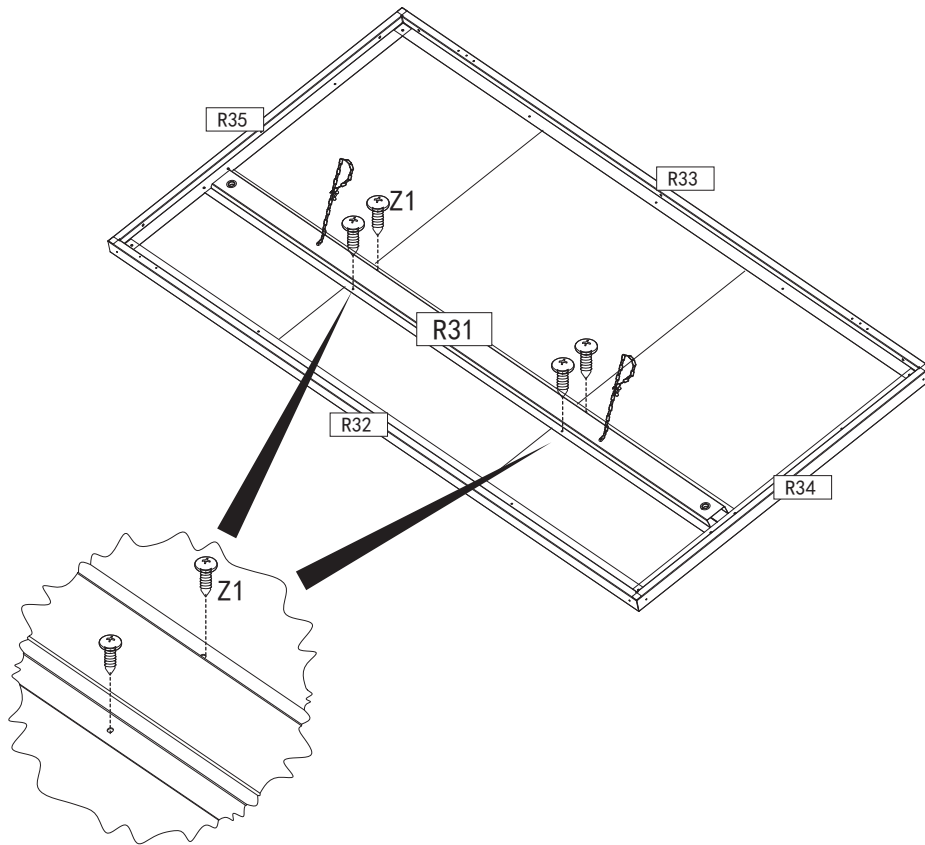

Z 1



4 PC

STEP35

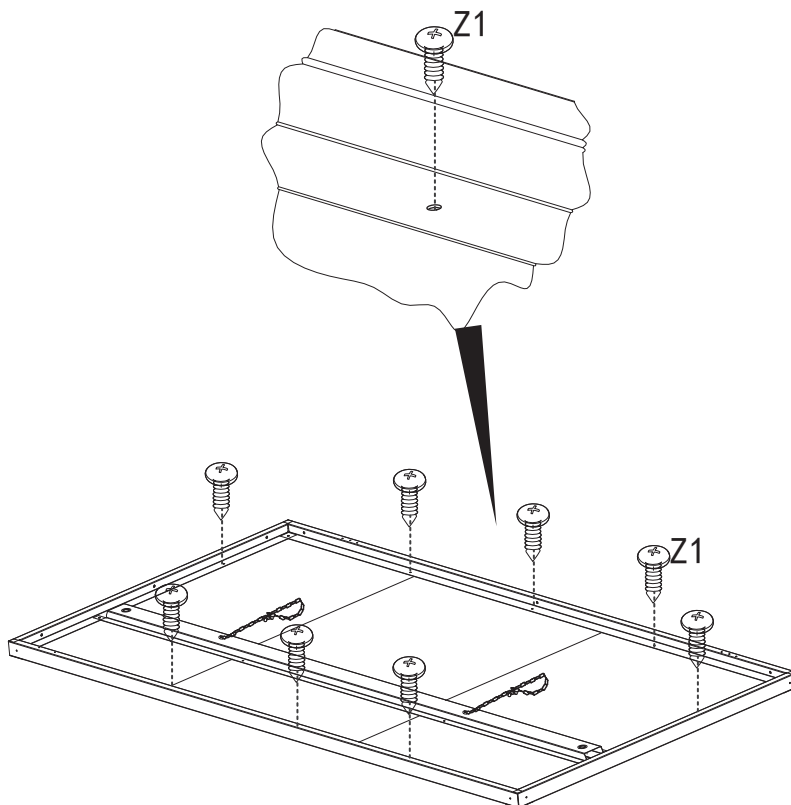



Z 1

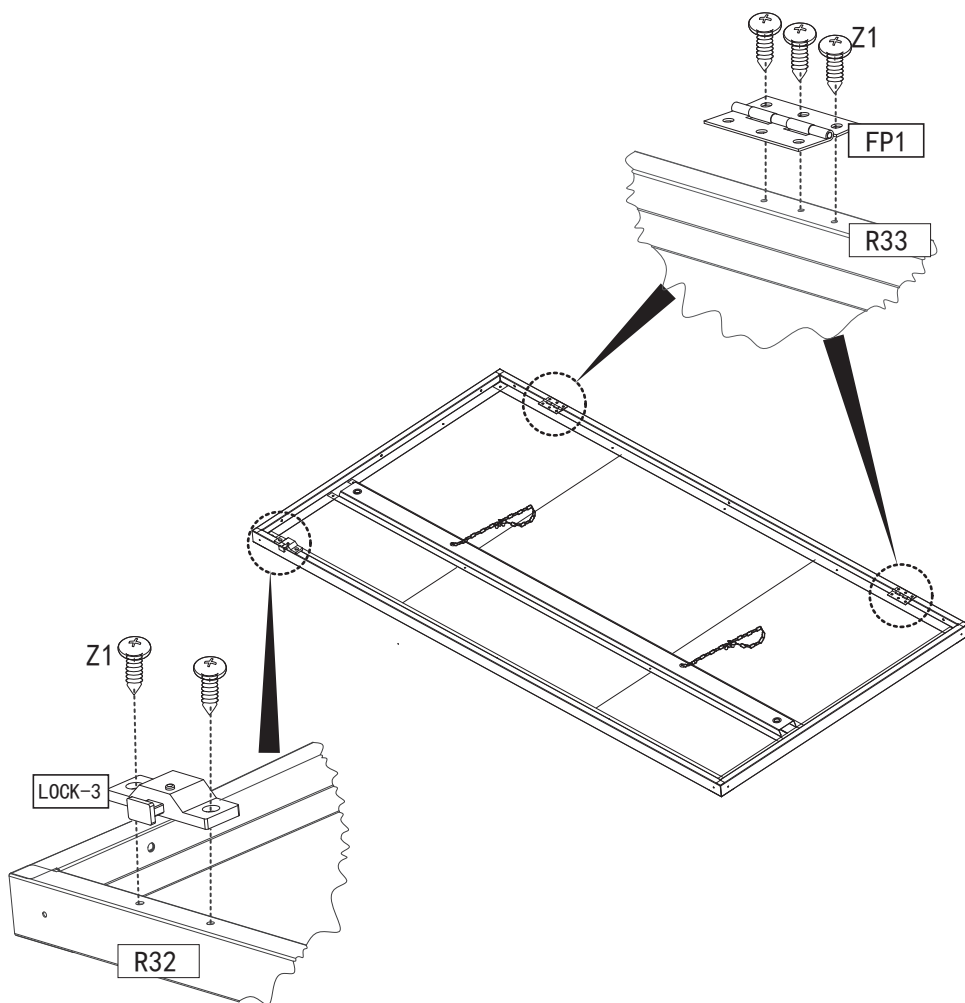

8 PC

STEP36

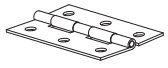
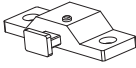

FP1

2 PC
LOCK-3

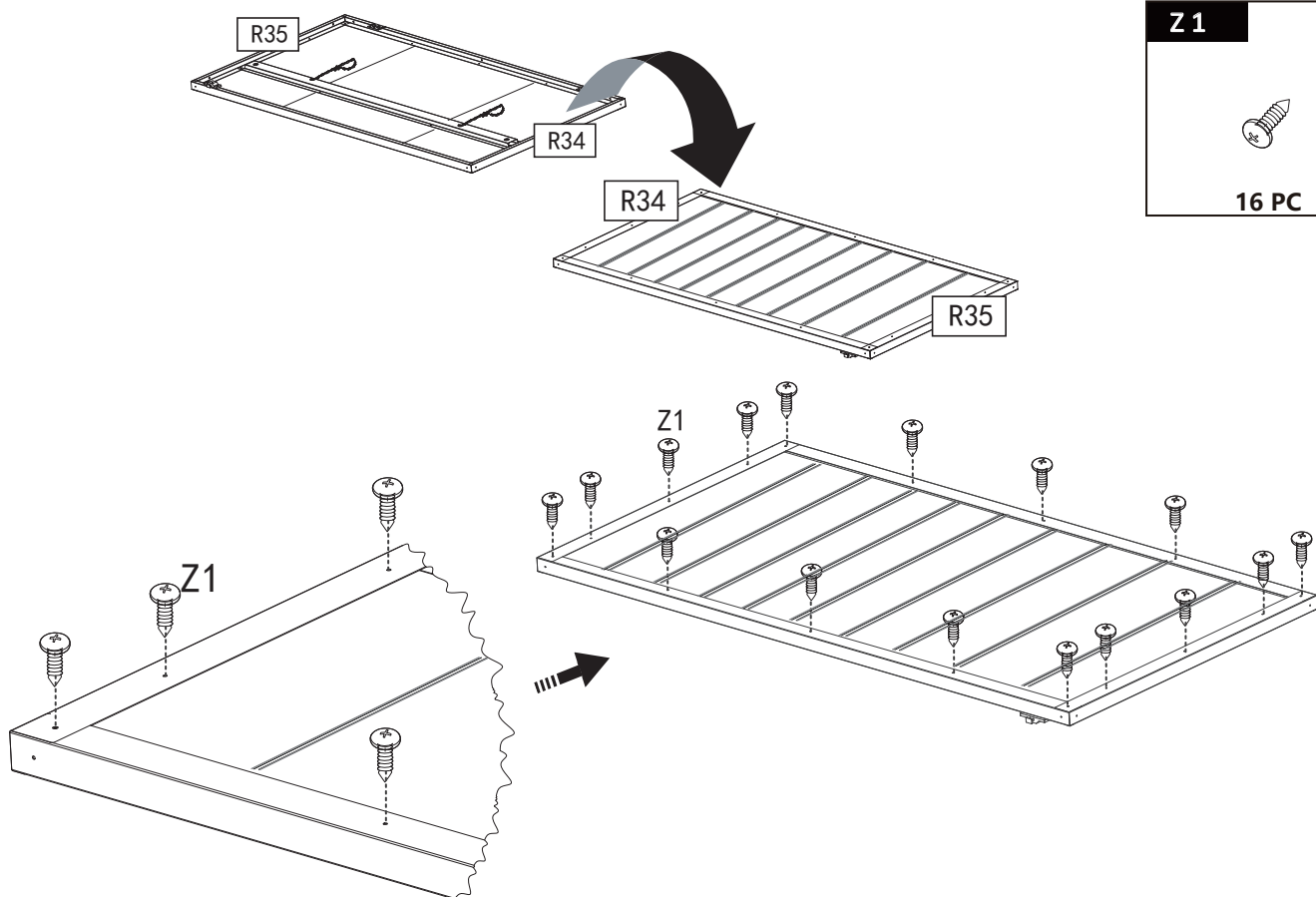
1 PC
Z 1

8 PC

STEP37

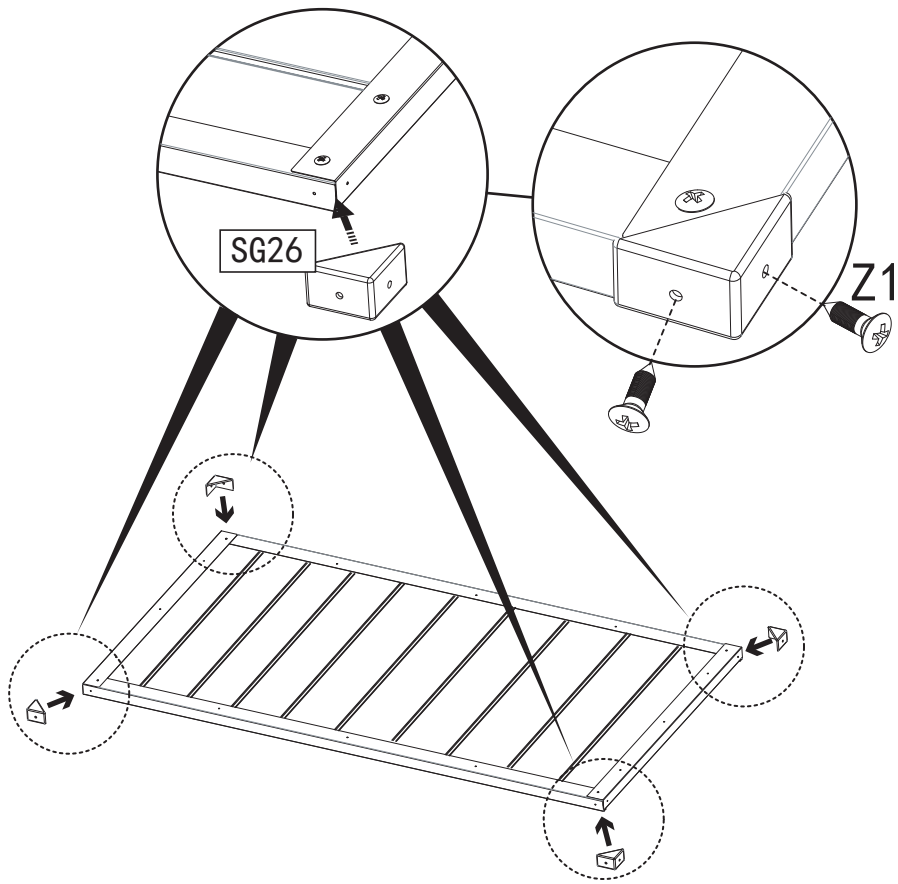

Z 1

16 PC

STEP38



SG26



4 PC

Z1



8 PC

STEP39

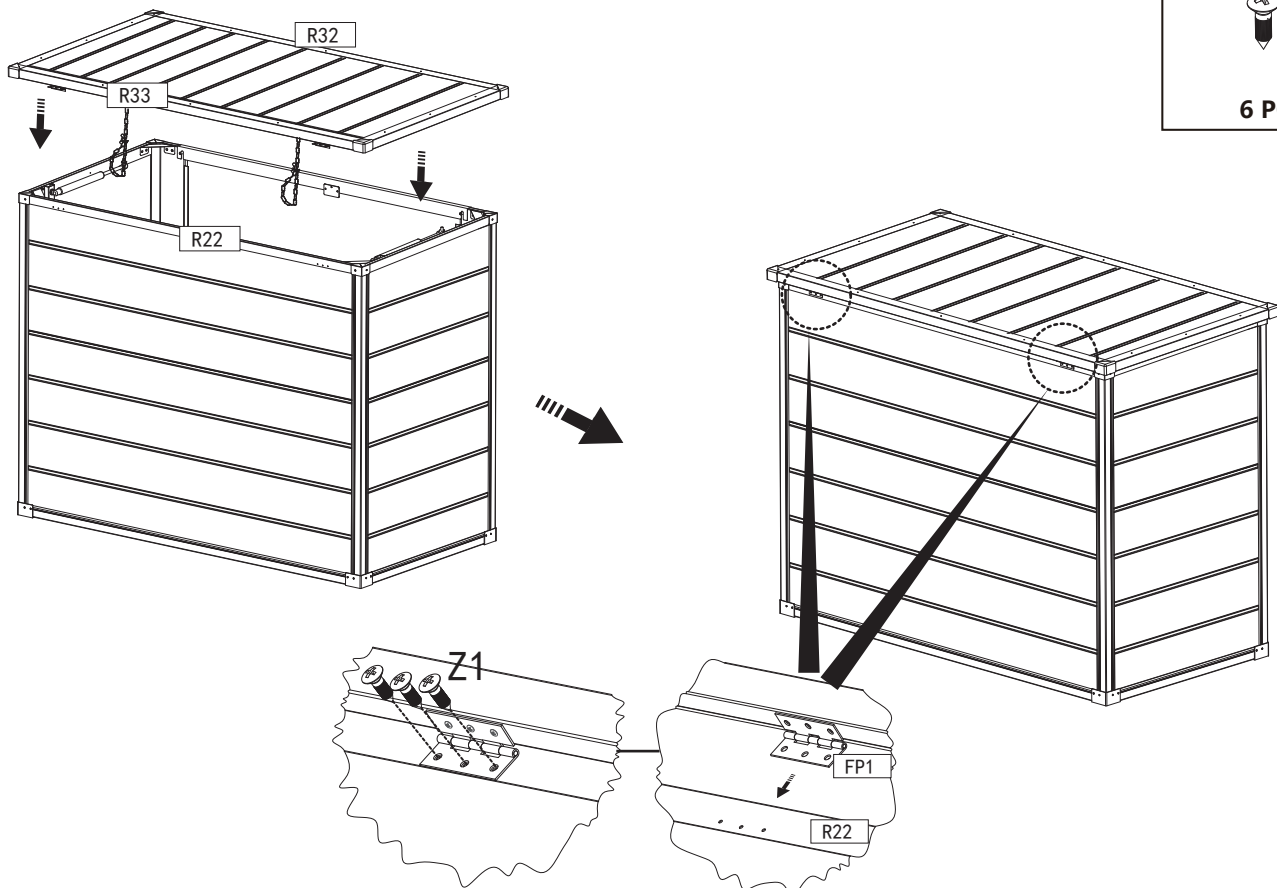

Z1



6 PC

STEP40

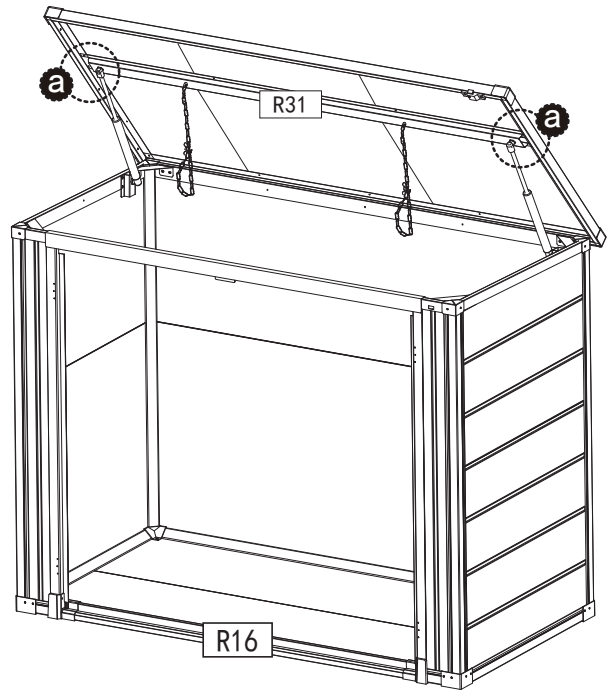
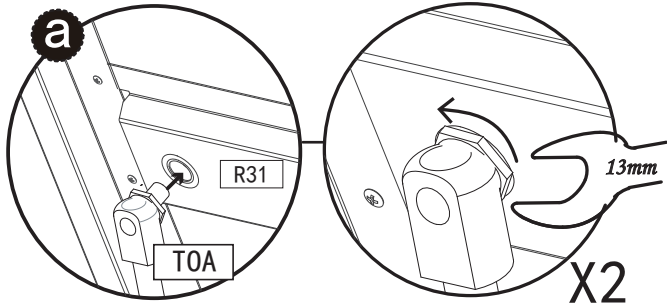

DOOR SECTION



Door mount this is above

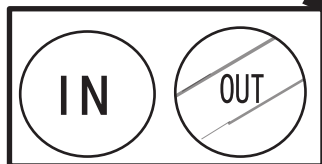
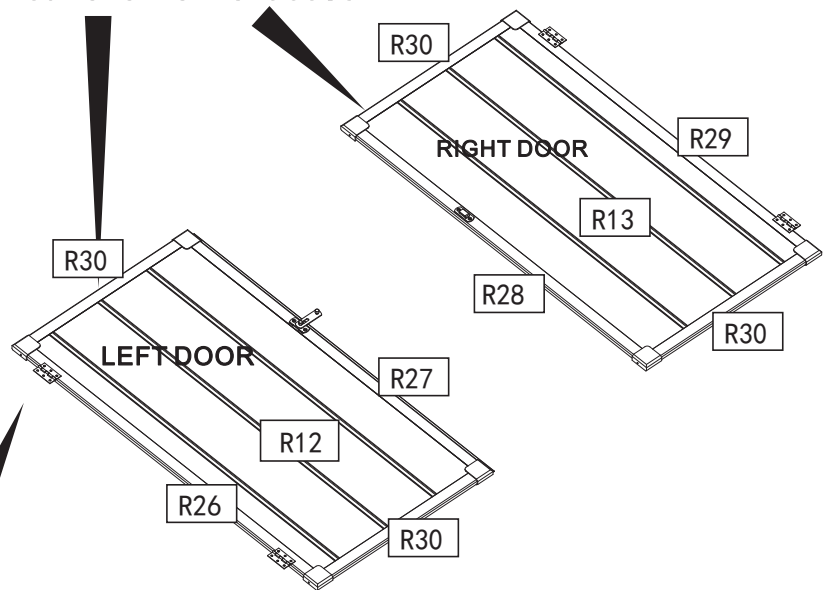

The stripes should be outside

LEFT DOOR

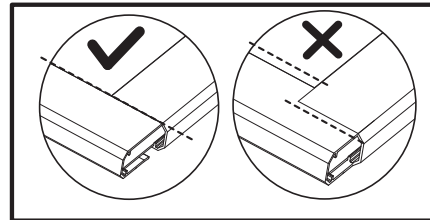
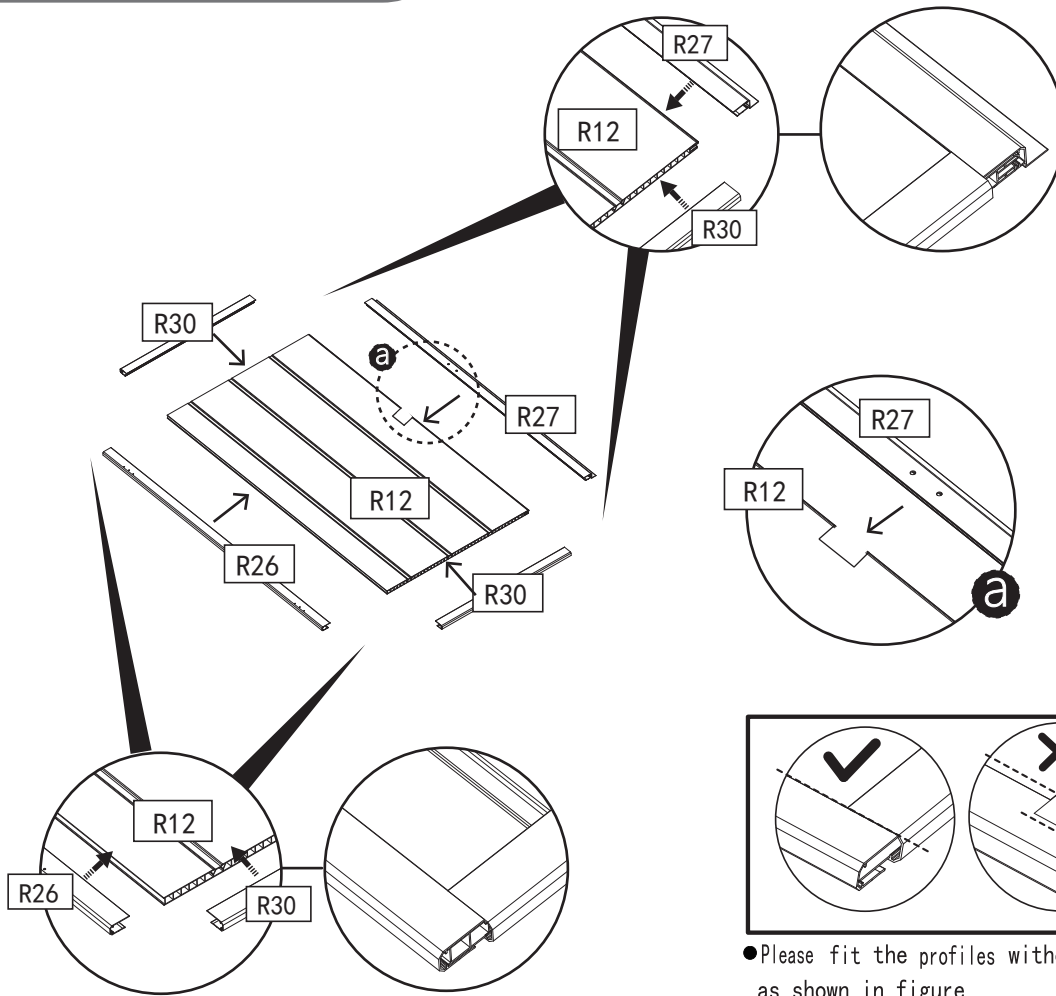

● Please fit the profiles without overlap as shown in figure

R12		1 PC
R27		1 PC
R26		1 PC
R30		2 PC
SG8		

STEP41

RIGHT DOOR

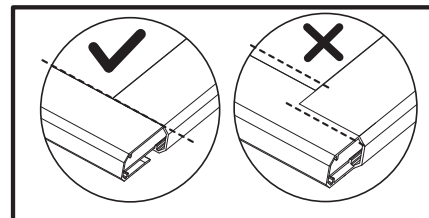
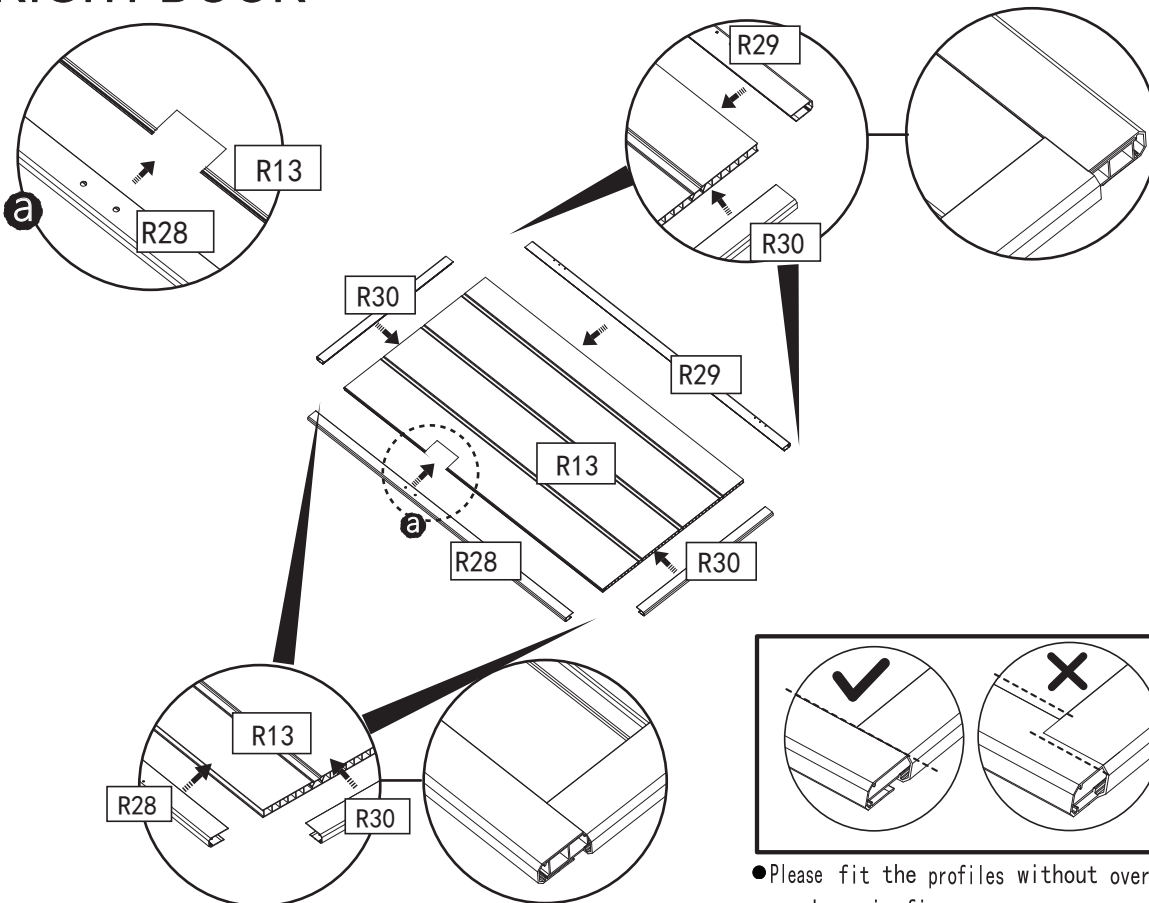

● Please fit the profiles without overlap as shown in figure

R13		1 PC
R28		1 PC
R29		1 PC
R30		2 PC
SG8		

STEP42

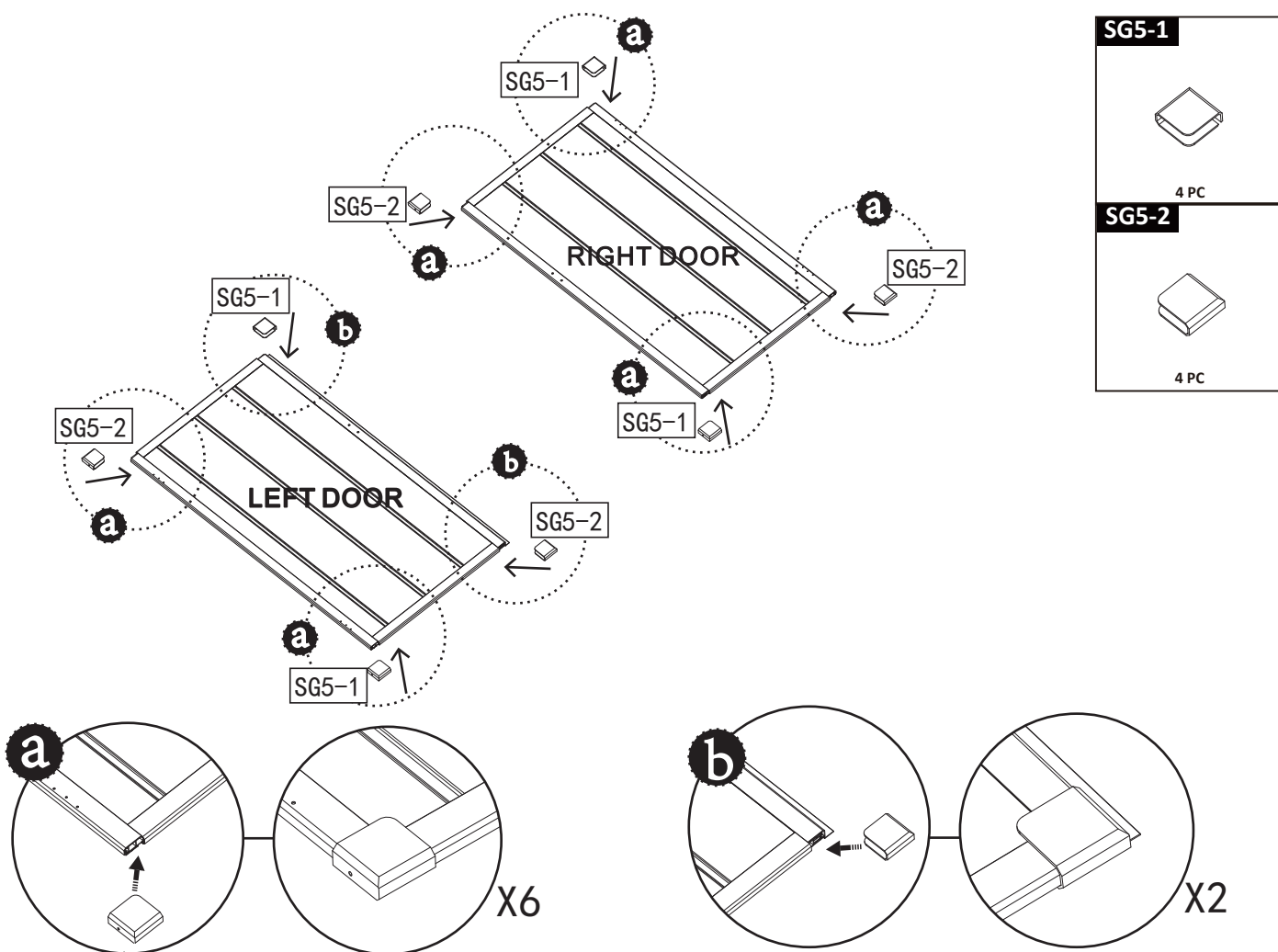

STEP43

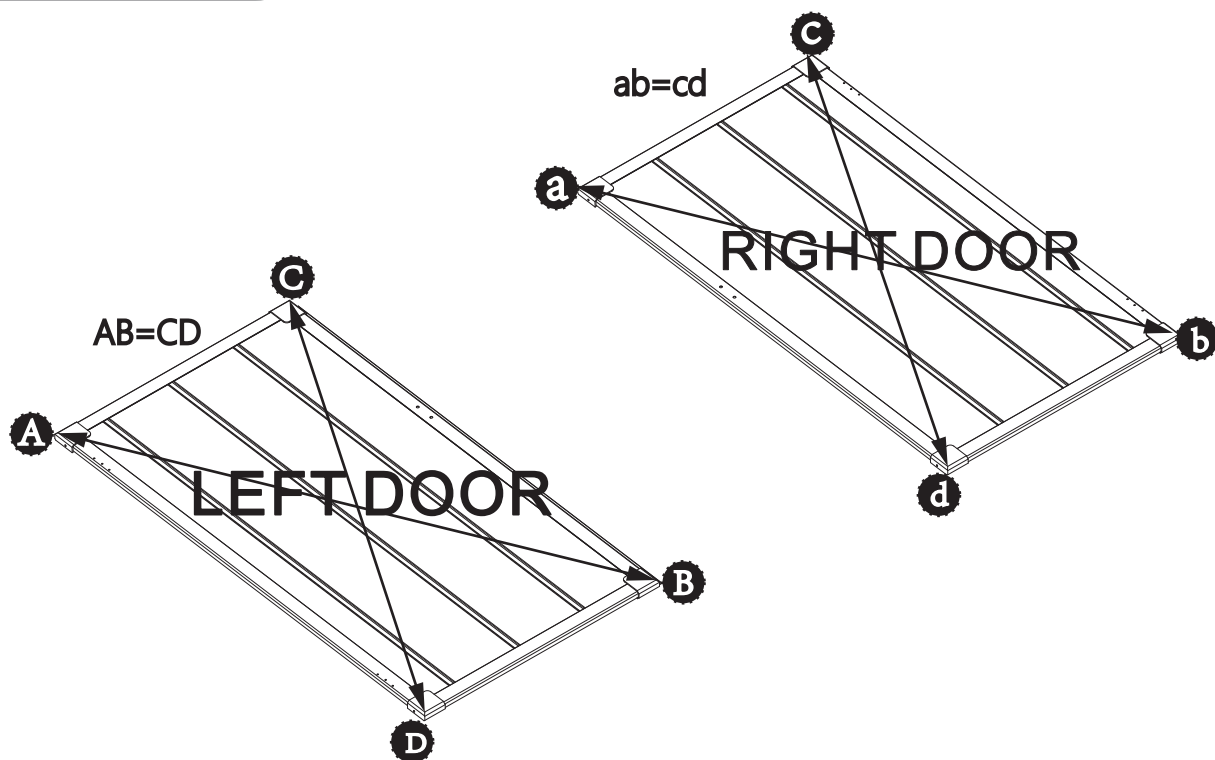

STEP44

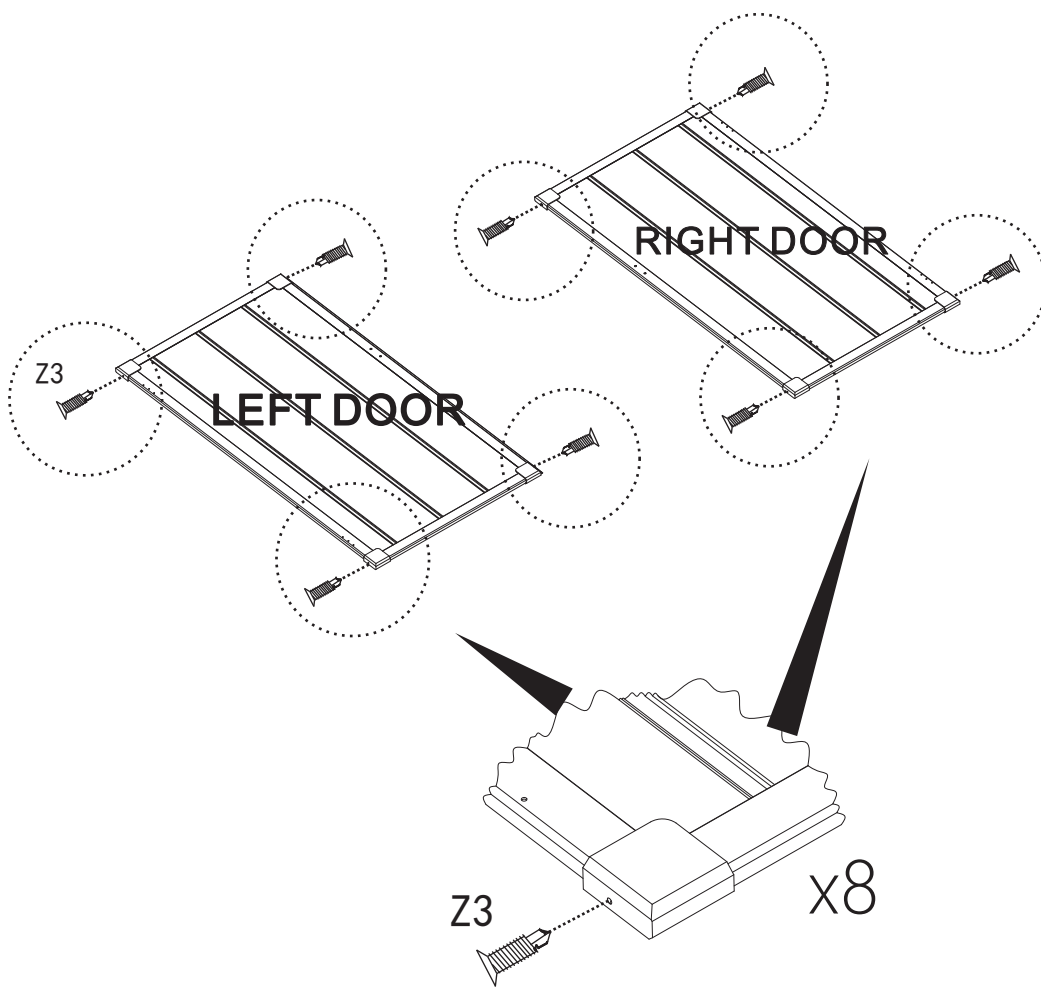

STEP45

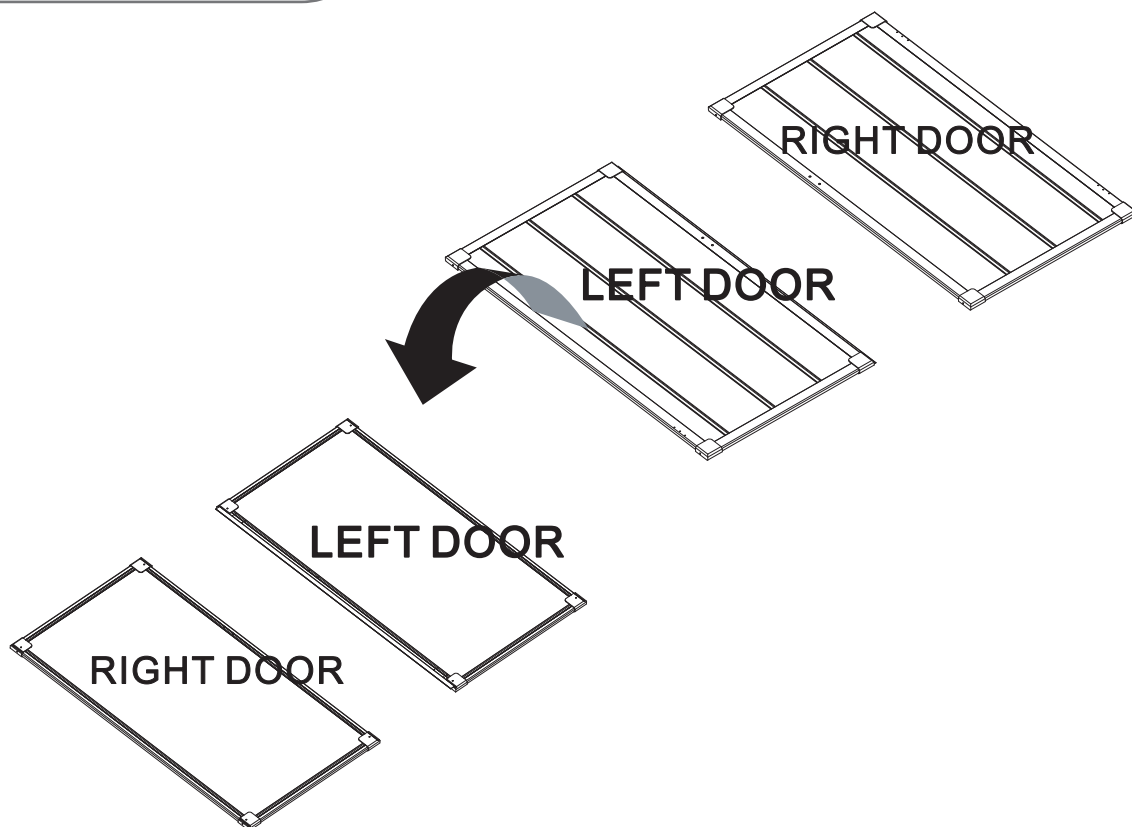

STEP46

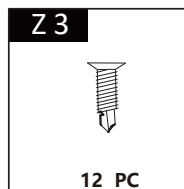
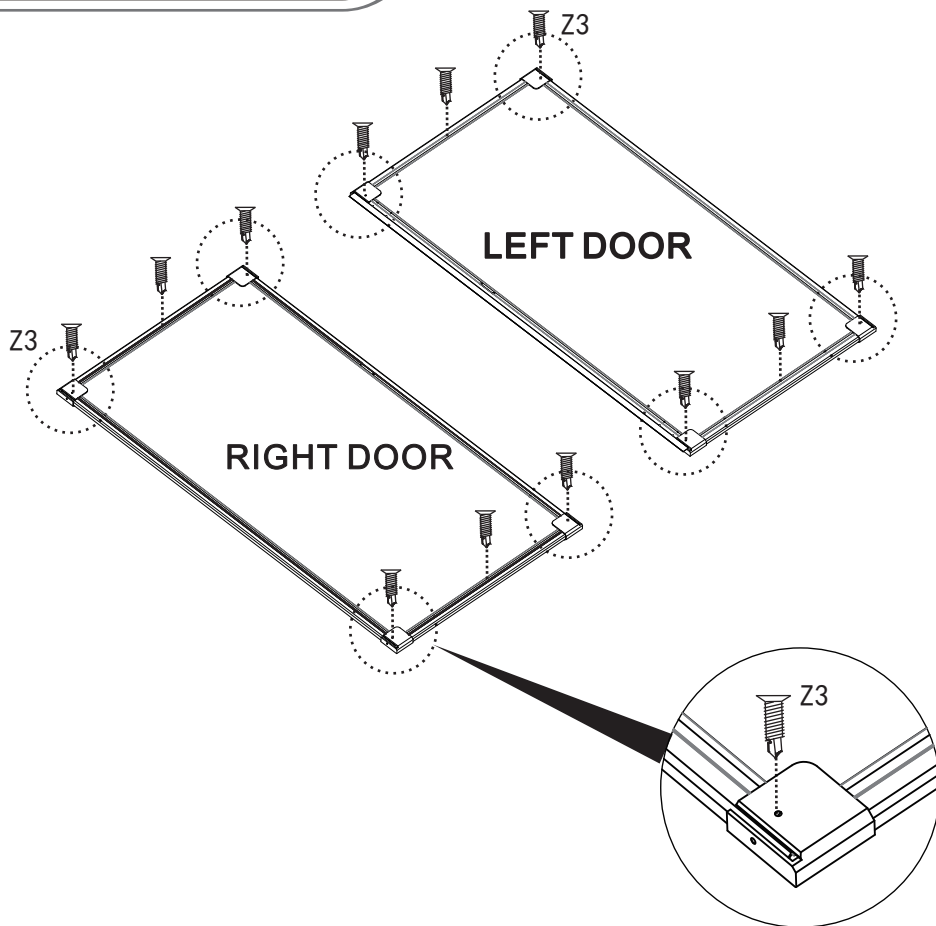

STEP47

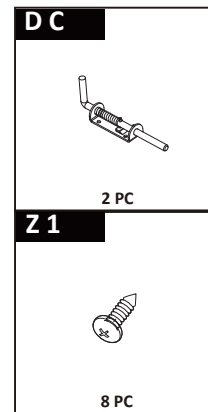
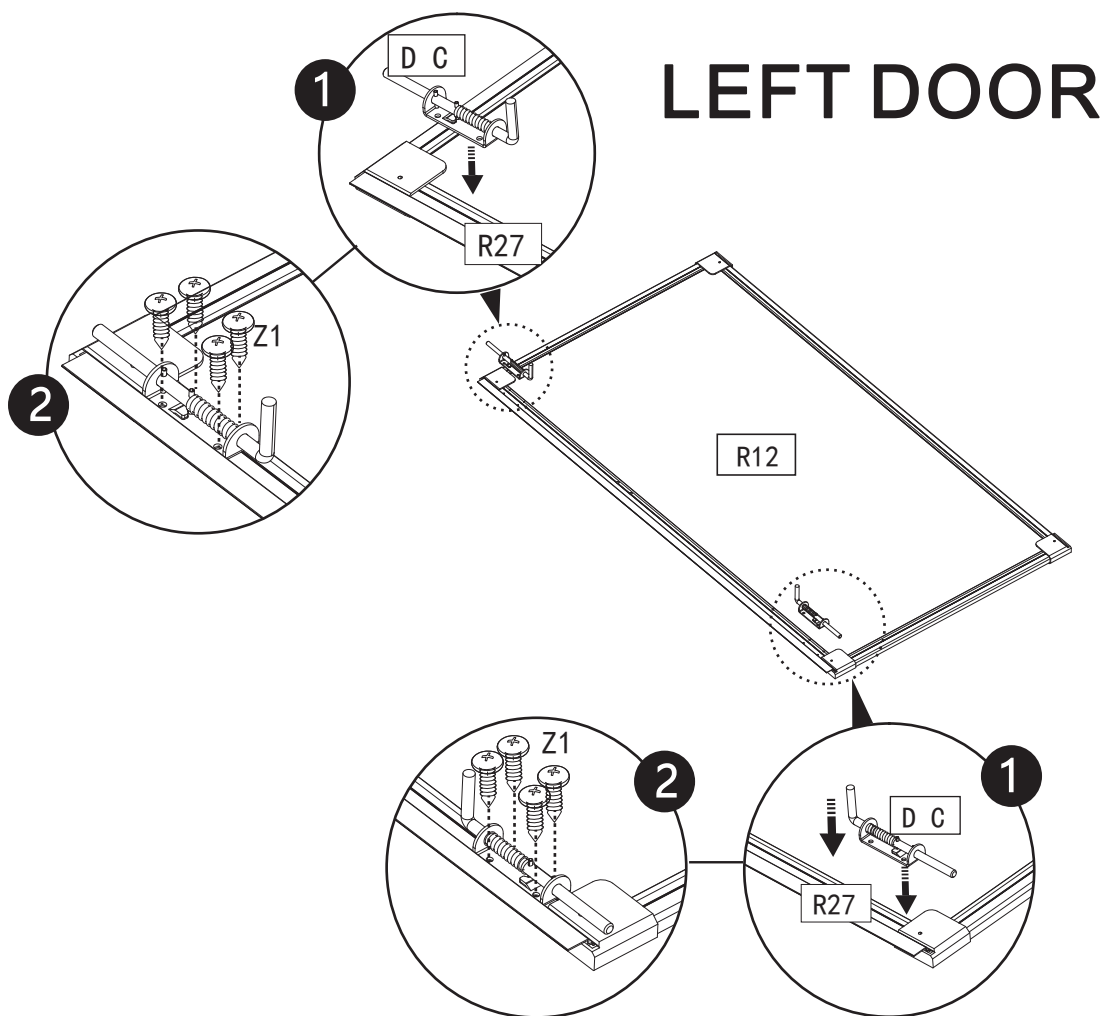

STEP48

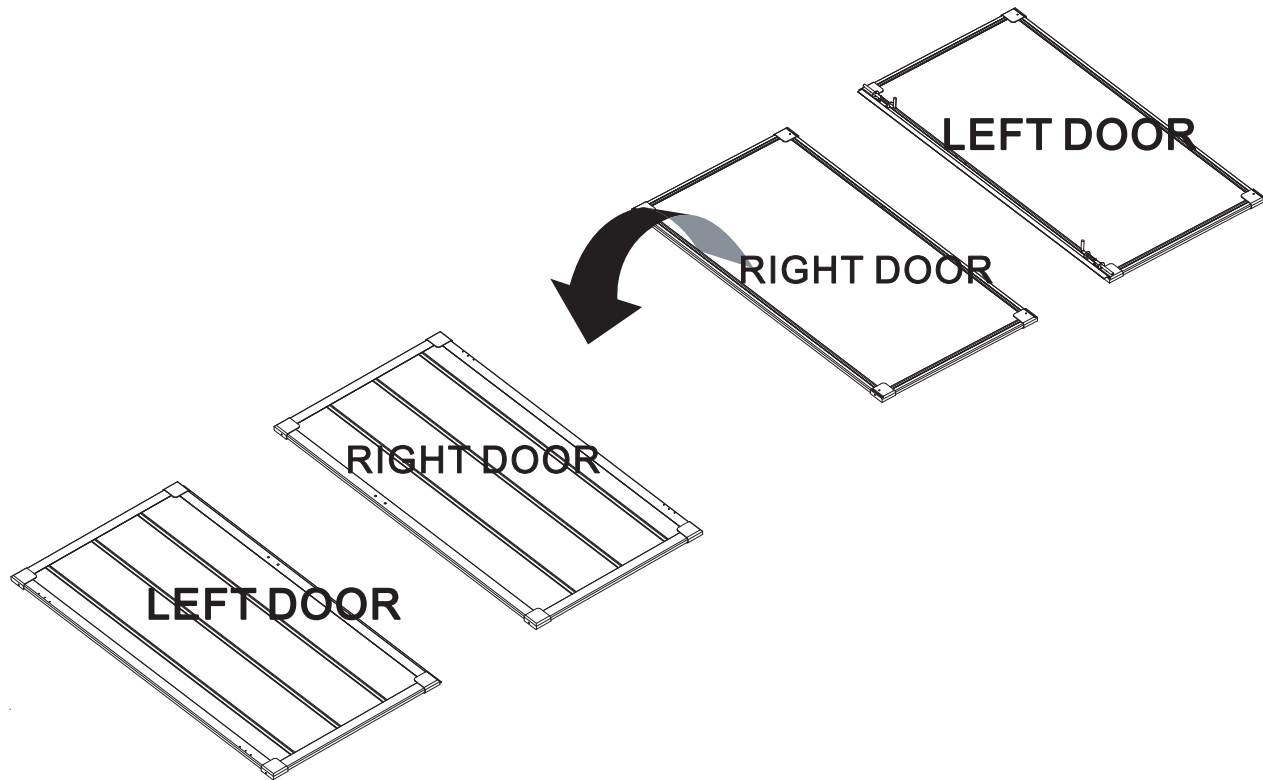

STEP49

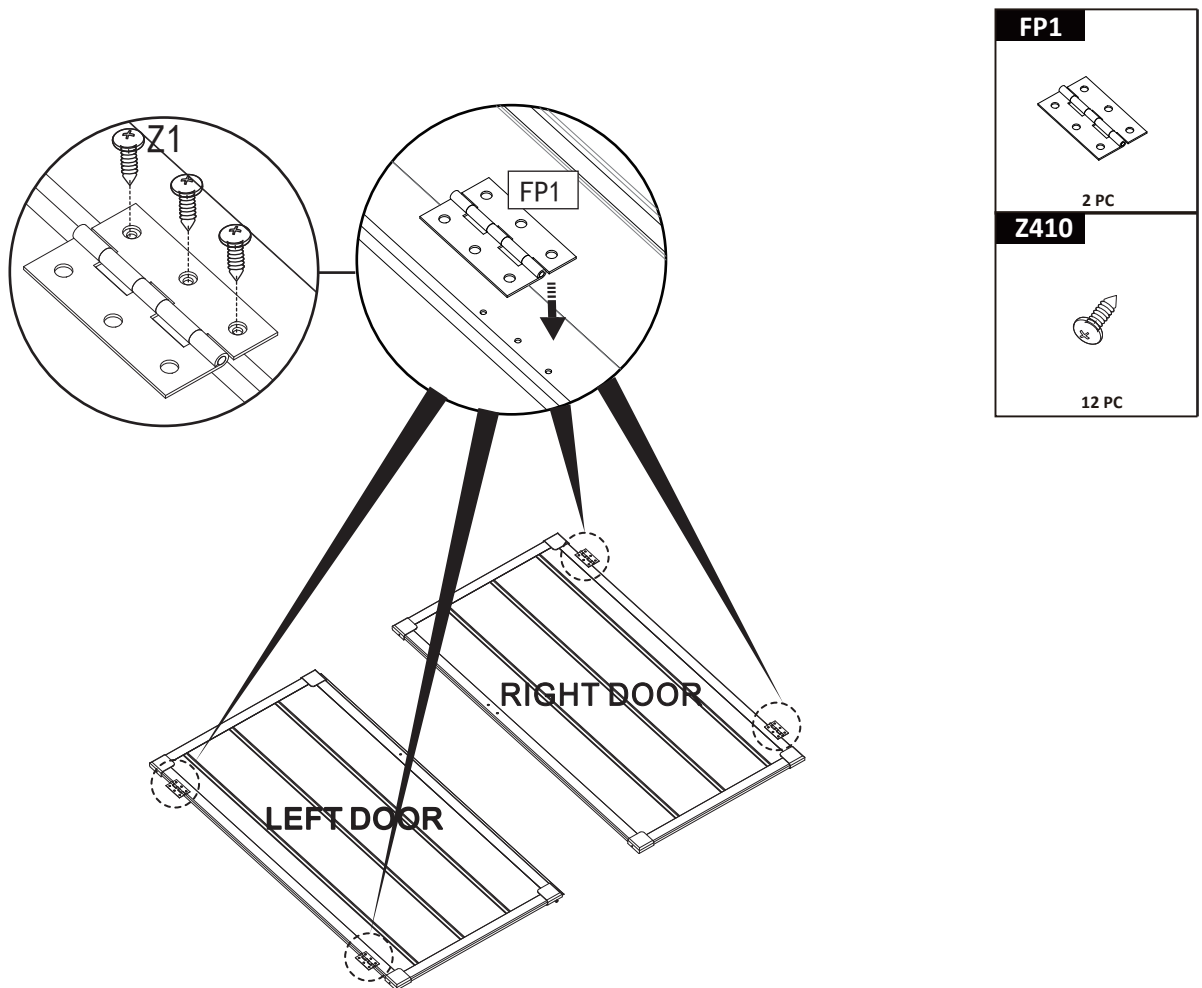

STEP50

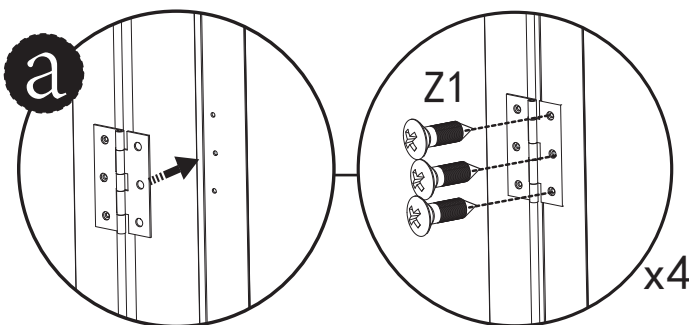
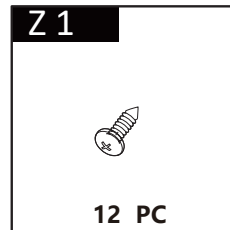

STEP51

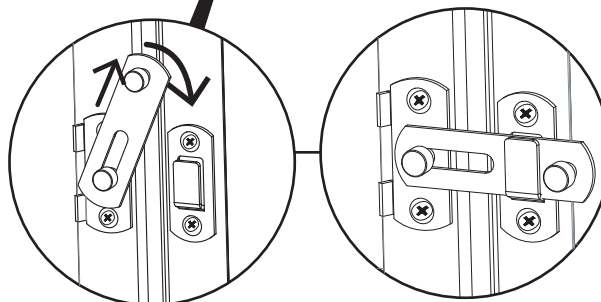
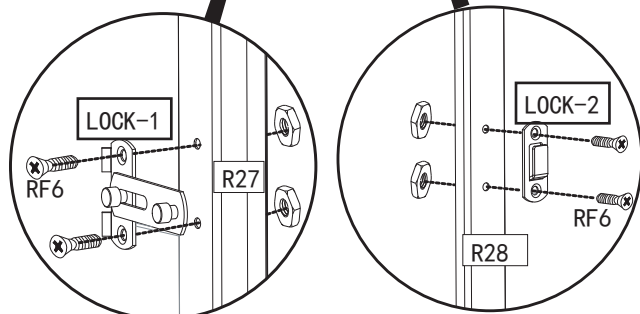
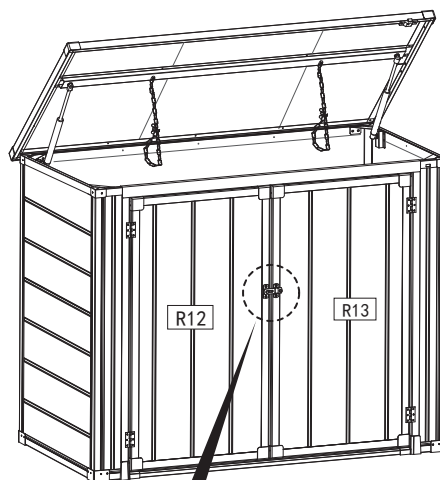
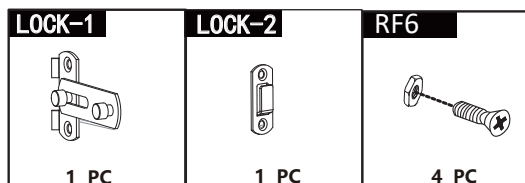
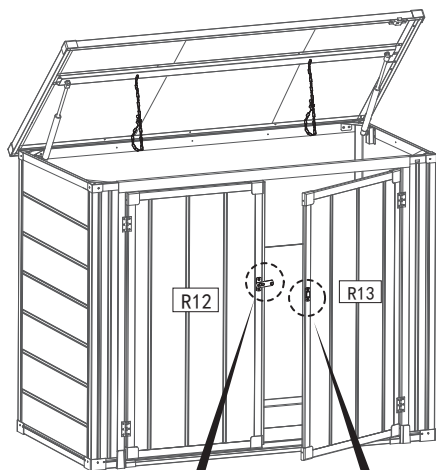

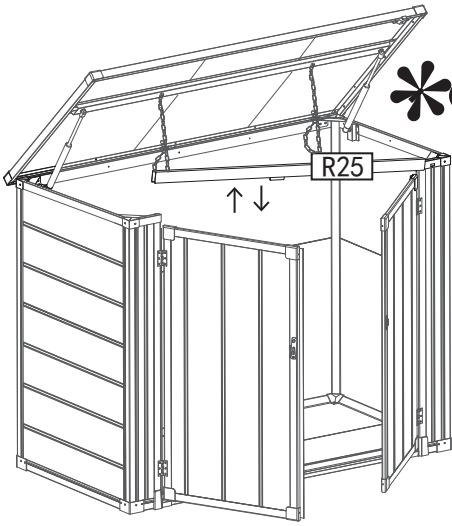

R25 can be removed when needed.

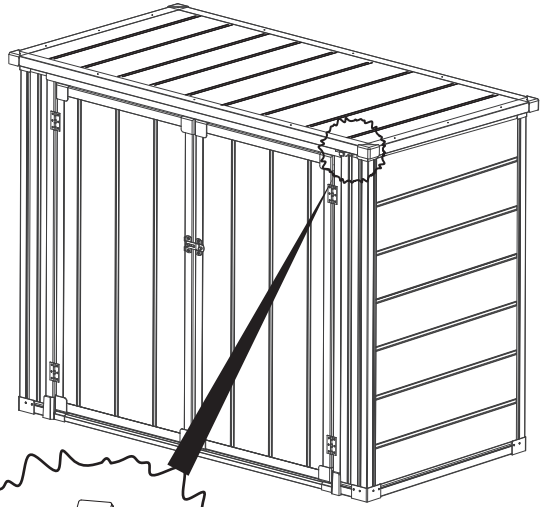

Press the button to lock after putting down the cover.

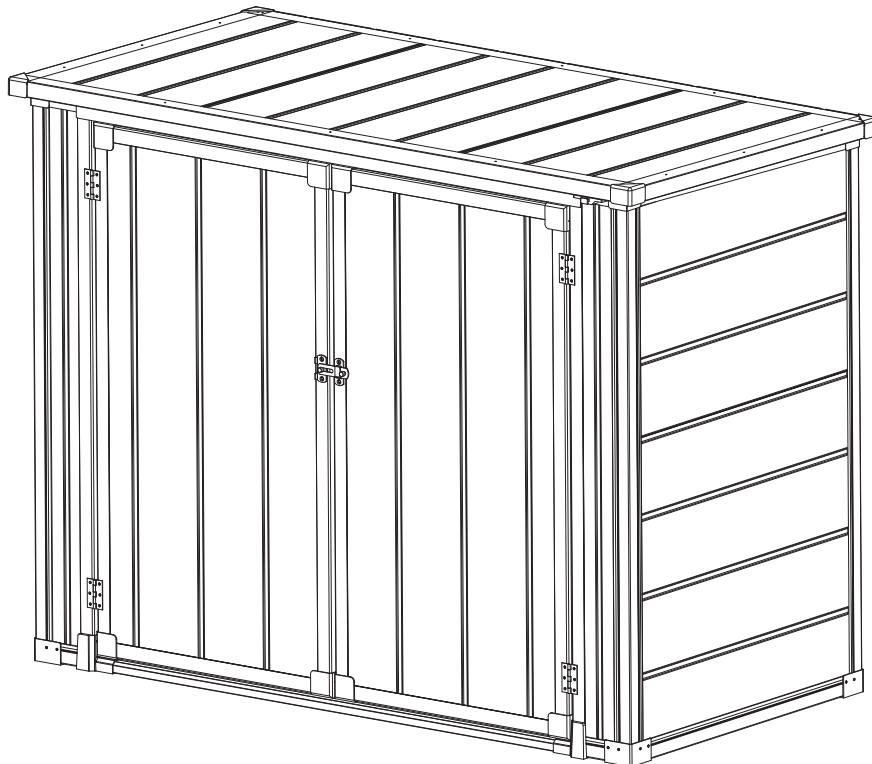
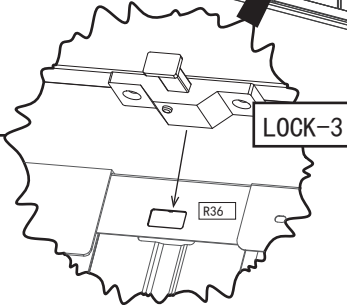
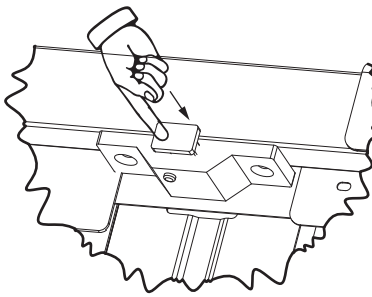

AFTER-SALE SERVICE CARD

If you have any suggestions for our products or find that the products have quality problems, please contact us first, our after-sales team will reply you within 24 hours, and we will do our best to give you solutions until you are satisfied.

Guaranteed Customer Service

Your shopping experience is very important to us!
Feel unsatisfied? **Contact us!**
Have any questions? **Contact us!**
Any suggestions? **Contact us!**
We gotcha back!

 Patiofurniture Serviceteam@outlook.com

