

Owner's Manual

Park Bench

NOTICE:

If your package is missing parts or you are having issues with assembly, please call us directly at
Our customer service team will address any questions or concerns you may have.
Have this manual open and ready for reference.

OUR BRAND

We are one of the nation's largest direct sellers of home decor. We offer an extensive selection of high-quality indoor and outdoor furniture, appliances, and accessories. We are committed to making decorating your home easy, affordable and fun. Everything you need to make your house into a beautiful home can be found at our manufacturer. So whether you shop by website or catalog, you can be sure you will always find top-quality merchandise for your home.









PLEASE LIKE, COMMENT AND SUBSCRIBE.

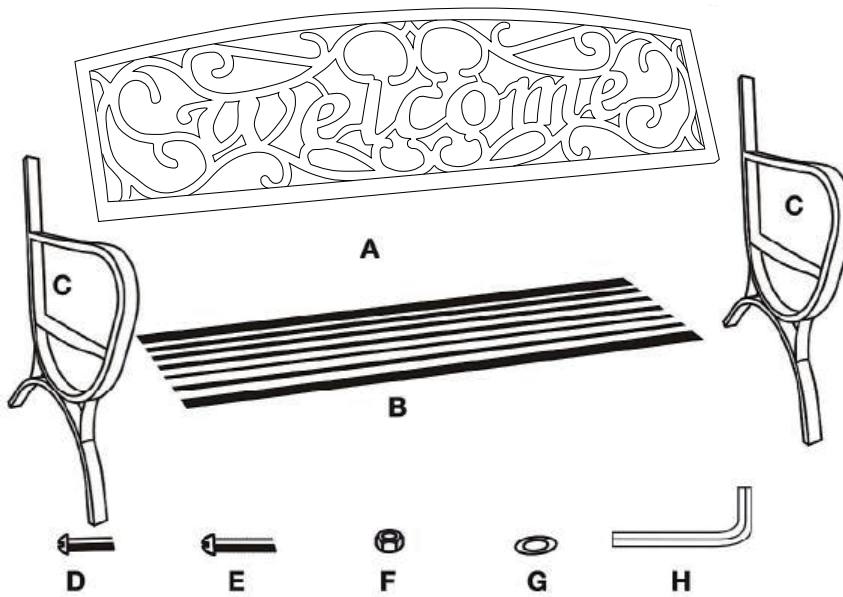

TABLE OF CONTENTS

OUR BRAND	03
INSTRUCTIONS MANUAL	04
MAINTENANCE	06
WARRANTY	07

INSTRUCTIONS MANUAL

PART #	IMAGE	DESCRIPTION	QUANTITY
A		Back	1
B		Seat PiPe	6
C		Legs	2
D		Screw, M6x15mm	12
E		Screw, M6x70mm	4
F		Hex Nut, 6mm	4
G		Flat Washer, 6mm	4
H		Hex Key	1



Carefully remove the contents from the package. If any parts are missing do not attempt to use the product until they have been obtained and correctly installed.

INSTRUCTIONS MANUAL

Figure 1

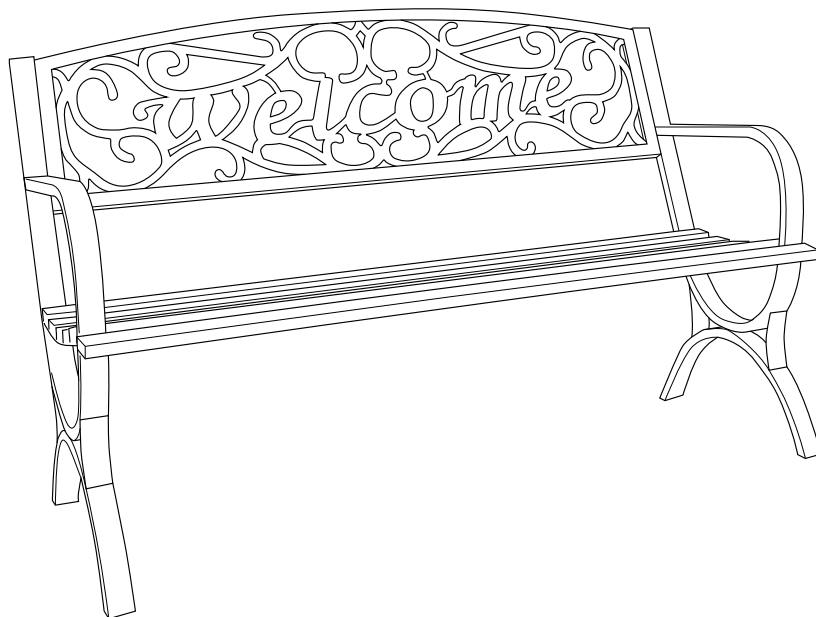
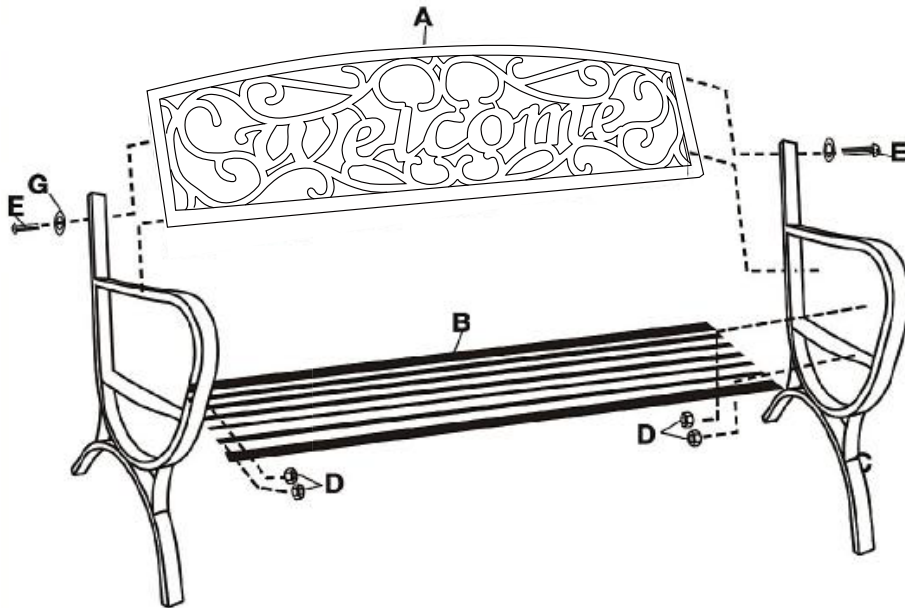

MAINTENANCE

Our iron/steel components for products are coated with rust inhibiting paint that protects it from rusting. However, due to the nature of iron, surface oxidation (rusting) will occur once these protective coatings are scratched. This is a natural process and is not a defect! To minimize this condition, we recommend care when assembling & handling the product to prevent scratching the paint.

ATTENTION

1. Keep all children and pets away from assembly area. Children and pets should be supervised when they are in the area.
2. Some parts may contain sharp edges. Wear protective gloves if necessary during assembly.
3. When assembling and using this product, basic safety precautions should always be followed to reduce the risk of personal injury and damage to equipment. Please read all instructions before assembly and use.
4. Check all bolts for tightness before and during usage.
5. Please take time to read these instructions thoroughly and follow each step carefully for safe and easy operation. Keep this manual for future reference.

LIMITED TERM WARRANTY

ONE (1) YEAR FROM DATE OF PURCHASE

WARRANTY TERMS

We warrant that our merchandise are free from manufacturing defects (workmanship and/or material) and will either give credit or replace defective parts for a period of up to one (1) year from the date of purchase in accordance with the conditions set forth below. If a manufacturing defect is found, we should be notified promptly of the defect and supplied a copy of the invoice and delivery ticket. We advise all retailers to retain invoices for a minimum of one (1) year for warranty purposes. This warranty supersedes and replaces all implied warranties of merchantability and use for particular purpose. Implied warranties or merchantability and fitness of the merchandise are limited to a period of one (1) year from the date of purchase. In no event shall we be liable for indirect, consequential or incidental damages of any kind.

ADDITIONAL CONDITIONS

The following examples are not manufacturer's defects:

- Colors may vary slightly from the photo because of photography and printing tolerances.
- Foam will soften slightly.
- Sizes are stated in U.S. standard measurements while the actual sizes are manufactured using the metric system. Therefore the sizes may vary slightly.
- There are no exchanges or refunds on any pillows or toppers sold.
- No returns for buyer's remorse.
- * No returns - other than stated above - will be accepted

ADDITIONAL CONDITIONS

Warranty is void for any of the following conditions:

- 1 Improper maintenance or improper use resulting in damage.
- 2 Any product modifications by dealer, consumer, or other parties not authorized by us will void this warranty.
- 3 Floor samples sold or products designated "AS IS" at the time of purchase are not covered by the warranty.
- 4 Warranty does not cover minor variations or differences between floor samples or printed illustrations and your furniture.
- 5 Cost of packaging and shipping to and from us are not covered by the warranty unless expressly arranged by us.
- 6 This warranty covers only articles of furniture intended for residential use only, does not cover any industrial, commercial, institutional, or rental use.
- 7 Dissatisfaction due to buyer's remorse.
- 8 Normal wear and tear.
- 9 Damages incurred during transportation.
- 10 Damages incurred during assembling or maintenance.
- 11 Damages incurred by accidents or abuse.

Additional conditions for warranty on upholstery are listed on the attached addendum.