

PACKAGE CONTENTS

3-LT LINEAR ISLAND

PART	DESCRIPTION	QUANTITY
A	Fixture	1
B	Glass shade	3
C	Socket ring	3
D	Canopy	1

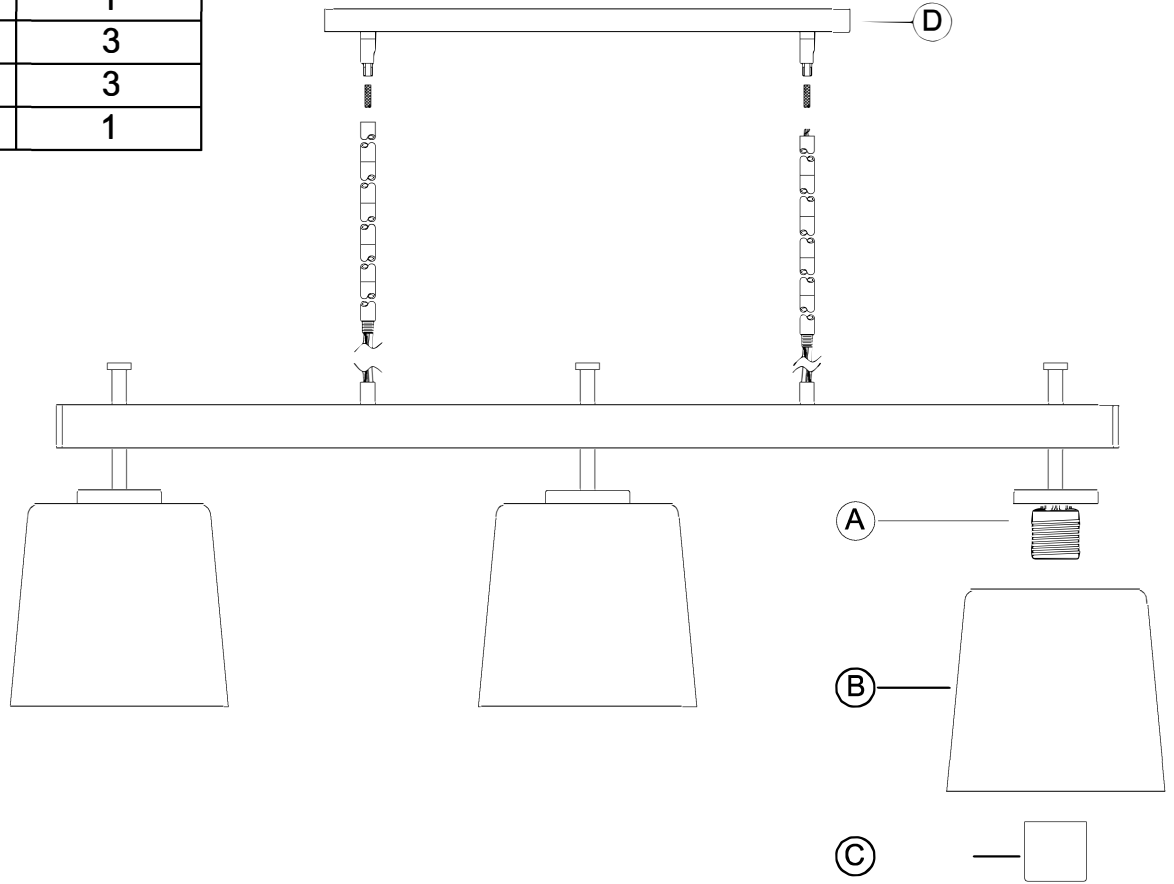

HARDWARE CONTENTS (not actual size)

AA	BB	CC	DD	EE	FF	GG	HH	JJ	KK	LL
Nipple (1/8IP)	Wire nut	mounting strap (1/8IP)	Hex nut (1/8IP)	Screw (#8)	Flat washer	Finial (1/8IP)	12" Pipe (1/8IP)	6" Pipe (1/8IP)	Nipple (1/8IP)	Fiberglass Sleeving
Qty:1	Qty:3	Qty:1	Qty:1	Qty:1	Qty:1	Qty:1	Qty:4	Qty:1	Qty:5	Qty:1



SAFETY INFORMATION

Please read and understand this entire manual before attempting to assemble, operate or install the product.

CAUTION: Read instructions carefully and turn electricity off at main circuit breaker panel before beginning installation.

CAUTION: Risk of fire. Min. 90°C supply conductors. Consult a qualified electrician to ensure correct branch circuit conductor

WARNING: If any Special Control Devices are used with this Fixture, follow instructions carefully to assure full compliance with N.E.C. requirements. If there are any questions, contact a qualified electrical contractor.

CAUTION: All glass is fragile, use care when handling glass shades and bulbs.

PREPARATION

1. Before beginning installation, make sure all parts are included using the contents diagrams from page 1. If any part is missing or damage, do not attempt to assemble, install or operate the product.
2. Estimated assembly time: 30 minutes.
3. Tools required for assembly (not included): Phillips screwdriver, pliers, wire stripper, safety glasses, electrical tape, ladder, drill.

CARE AND MAINTENANCE

Shut off main power supply before cleaning product or changing light bulbs. To clean, wipe with damp cloth. Do not use abrasive cleaners or cleaners that contain alcohol.

ASSEMBLY INSTRUCTIONS

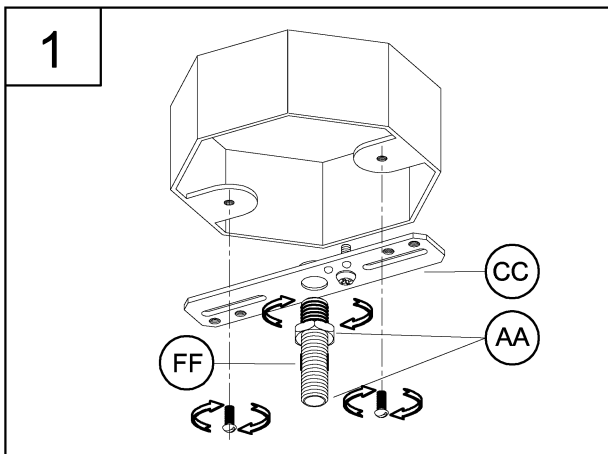

1. Loosely thread the hex nut (AA) onto the nipple (FF) and then install this assembly onto the mounting strap (CC). Next, install this assembly to the outlet box using the mounting screws supplied with the outlet box (not included).

2. In this step, you will adjust the depth of the nipple in relation to the canopy depth.

Take the canopy (HH) and slip it over the nipple (EE). You will need to adjust the nipple so at least 1/4" of the threaded portion is exposed through the canopy hole. This is done by adjusting the depth of the nipple (FF) on the mounting strap (CC). When the nipple depth is correctly adjusted, remove the canopy (HH) and tighten the hex nut (AA) against the mounting strap (CC).

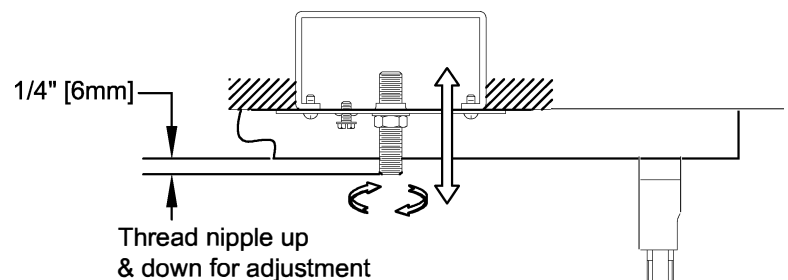
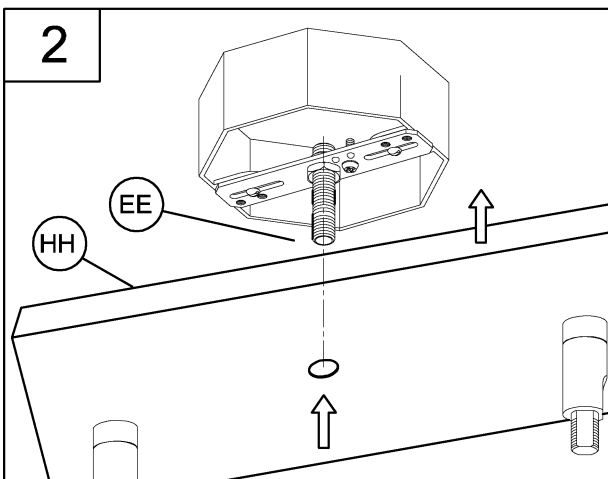

ASSEMBLY INSTRUCTIONS

3

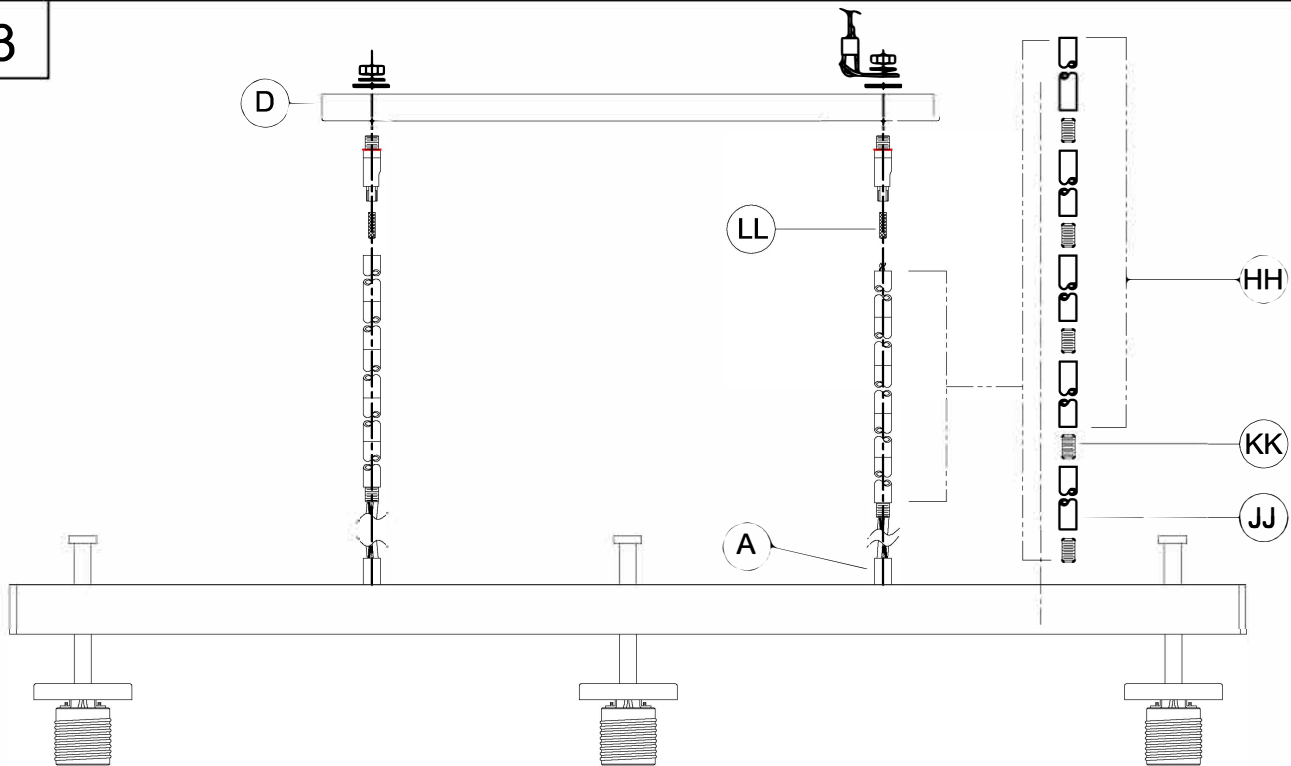

NOTE: During this step, determine the hanging length of your fixture by adding or removing pipes. The electrical and ground wire may also optionally be cut to length. Remove the swivels if they are already assembled to the canopy. You will re-assemble them onto the top of the last pipe before wiring has been passed through during this step. Align them so they will swivel in the same direction.

Do NOT cut electrical or ground wires until this length is determined. Leave AT LEAST 6 inches MINIMUM of wire past the canopy (D) to allow for easy connections in step 5.

3. Determine the hanging height of the fixture and number of pipes (HH) / (JJ) needed for each side of the fixture at this time. Ensure that you have equal length pipes on each side. Pass the wires through the pipes (JJ) / (HH), nipples (KK) and swivels as shown on the diagram. Tighten the remaining pipes and swivels to the assembly as you go to avoid twisting the wires. Slide the fiberglass sleeve (LL) over the wires and push up into the swivels to protect the wiring. Now re-install the fixture back onto the canopy (D), re-using the flat washers, lock washers and hex nuts. Also re-install the safety cable under one of the lock washers. Tighten the hex nuts, making sure the swivels are aligned to swivel in the same direction.

4

You now need to attach the fixture support cable. This cable will aid you in supporting the fixture during the wiring connection in step 5. You will need a helper to help hold up the fixture during this step.

Make sure the supply wire is out of the way from the drill for this step.

Use a #29 drill (\varnothing .136) or (3.5mm) bit to create a mounting hole in the side of the junction box.

Next, using the self threaded screw (EE) and flat washer (FF) provided, secure the support cable into the hole you just drilled in the junction box. Tighten securely.

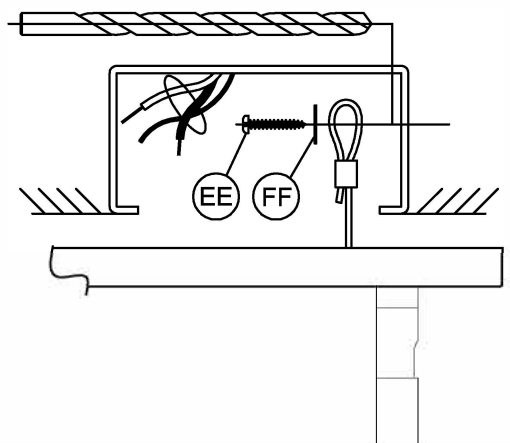

ASSEMBLY INSTRUCTIONS

5

Strip 3/8" of insulation from the electrical wire ends. Using the wire nuts (BB), connect the RIBBED fixture wire to the WHITE supply wire from the junction box; connect the SMOOTH fixture wire to the BLACK supply wire from the junction box.

Connect the fixture ground wire and supply ground wire together using a wire nut, or fasten both to the ground screw on the mounting strap. Push all the wire connections carefully into the outlet box.

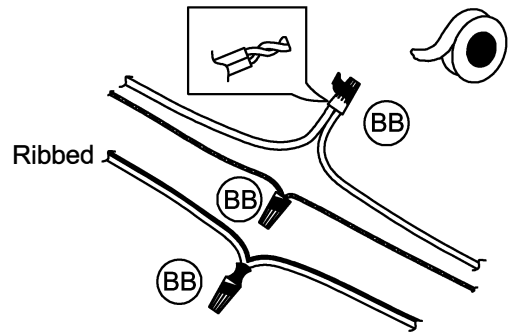

6

6. Position and attach the canopy (D) onto the nipple (AA) using the finial (GG) to secure the canopy (D) tightly to the ceiling.

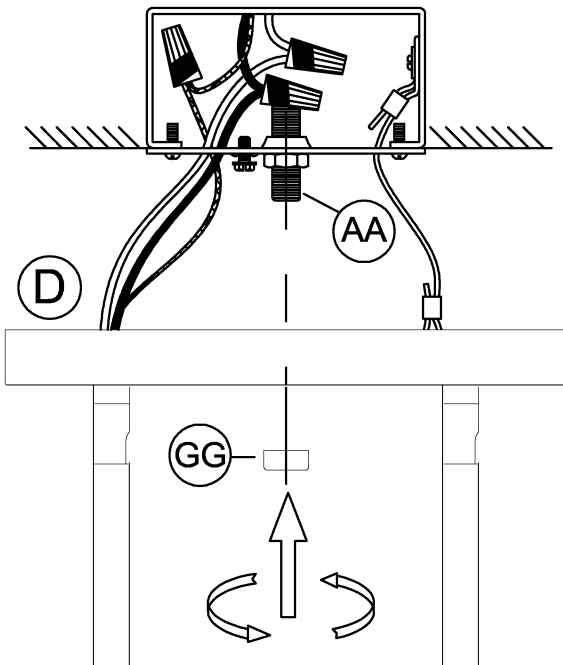

7

7. Attach the glass shade (B) to the fixture (A) using the socket ring (C) to secure it tightly.

Thread the lamps (not included) into the fixture sockets. Use 60-watt MAX incandescent medium base lamps, SBCFL or SBLED.

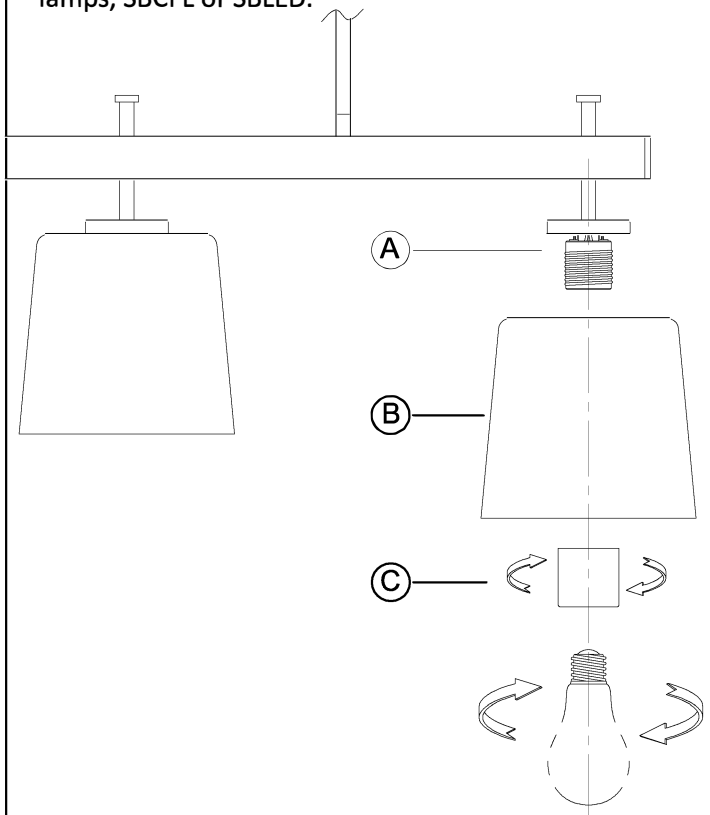

WARRANTY AND EXCLUSIVE REMEDY: Progress products, when properly installed and under normal conditions of use, are warranted to our customers only to be free from defects in material and workmanship at time of shipment. All warranty claims must be asserted within one year from date of purchase of the subject items; thereafter, warranty claims will not be honored. Customers' sole remedy for a warranty claim or otherwise shall be limited to repair or replacement of the subject product if it is shown to have been defective in material or workmanship at time of shipment. Progress's sole and maximum liability for a defective product shall never exceed the cost of the subject product. **EXCEPT FOR SUCH A WARRANTY AND EXCLUSIVE REMEDY AS STATED (AND THE EXPRESS WARRANTY OF TITLE), WE DISCLAIM ALL OTHER WARRANTIES, WHETHER EXPRESS OR IMPLIED, AND SPECIFICALLY DISCLAIM THE IMPLIED WARRANTIES OF MERCHANTABILITY AND FITNESS FOR A PARTICULAR PURPOSE. IN NO EVENT SHALL WE BE LIABLE TO CUSTOMER IN WARRANTY, CONTRACT, NEGLIGENCE, STRICT LIABILITY OR OTHERWISE, FOR ANY DAMAGES, WHETHER INCIDENTAL OR CONSEQUENTIAL, WHICH ARE ALLEGED TO BE CAUSED BY ONE OR MORE OF OUR PRODUCTS, BEYOND THE COST TO THE CUSTOMER OF THE SUBJECT PRODUCT OR PRODUCTS.** Therefore, the customer's sole and exclusive remedy against us for breach of the warranty, breach of contract or negligence or strict liability or otherwise shall be limited to repair or replacement of the subject product at our option (excluding installation and removal charges which shall not be our liability) or, if we choose, refund of the purchase price. In no case does our warranty and exclusive remedy extend to anybody other than our customers. Our customers are not authorized to extend warranties or remedies on our behalf to anyone. Such unauthorized extensions of warranties or remedies by the customer shall remain customer's responsibility. Customer is responsible for determining the suitability of our products for customer's use or resale, or for incorporating them into objects or for applications which customer designs, assembles, constructs or manufactures.

Instructions d'Assemblage et Installation

Mise en garde: Lire les instructions avec soin et couper le courant au disjoncteur central avant de commencer l'installation.

MISE EN GARDE: Lire les instructions avec soin et couper le courant au disjoncteur central avant de commencer l'installation.

MISE EN GARDE: Risque d'incendie. Min 90°C conducteurs d'alimentation. Consulter un électricien qualifié pour assurer le bon conducteur de circuit de dérivation.

AVERTISSEMENT - S'il y a d'autres mécanismes régulateurs qui s'emploient avec ce dispositif, suivre soigneusement les instructions pour satisfaire aux exigences NEC. Si vous avez des questions, consulter un électricien qualifié.

MISE EN GARDE - Le verre est toujours fragile; maniez le(s) composant(s) et/ou l' (les) ampoule(s) avec prudence.

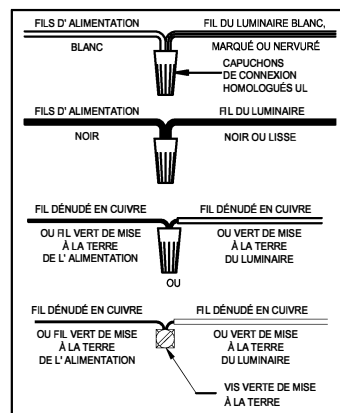

Instrucciones de ensamblaje e instalación

Precaución: Lea cuidadosamente las instrucciones y desconecte la electricidad del cortacircuitos principal antes de iniciar la instalación.

PRECAUCIÓN: Lea cuidadosamente las instrucciones y desconecte la electricidad del cortacircuitos principal antes de iniciar la instalación.

PRECAUCIÓN: Riesgo de fuego. Min. 90°C los cables de suministro. Consulte a un electricista calificado para asegurarse de que el conductor del circuito derivado correcto.

ADVERTENCIA - Si usa algún dispositivo especial de control con este aparato de luz, siga las instrucciones cuidadosamente para asegurar la completa conformidad con los requisitos N.E.C. Si existe alguna duda, contacte un electricista calificado.

PRECAUCION - El vidrio es frágil; tenga cuidado al manipular el (los) elemento(s) de vidrio y/o la(s) bombilla(s).

