

HEADBOARD AND FOOTBOARD SET ASSEMBLY INSTRUCTION (TOTAL 1 BOX)

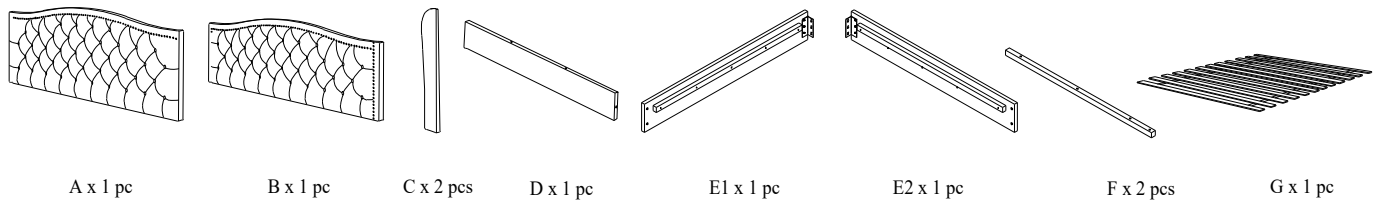

Please read over the instructions, it will be a time-saver in the long run.
 Note: Before assembly, please be sure to work on a soft flat surface to avoid any damage to the finish.
 Please leave bolts loosened until all bolts are placed before tightening completely.

Part#	Picture	Description	QTY	Location	Part#	Picture	Description	QTY	Location
K		Center leg	6	Wrapped in a non-woven bag	T		Spring Washer Ø8	2	Already in Place
L		Legs	2	Wrapped in a non-woven bag	P		Bolt Ø6x30mm	6	Already in Place
O		Bolt Ø8x60mm	6	Hardware Pack	R		Flat Washer Ø6x20mm	6	Already in Place
N		Bolt Ø8x40mm	8	Hardware Pack	Q		Spring Washer Ø6	6	Already in Place
M		Bolt Ø8x30mm	2	Already in Place	W		"L" Wrenches Ø5	1	Hardware Pack
U		Flat Washer Ø8x25mm	14	Hardware Pack	X		"L" Wrenches Ø4	1	Hardware Pack
		Flat Washer Ø8x25mm	2	Already in Place	S		Screws 4x40mm	48	Hardware Pack
T		Spring Washer Ø8	14	Hardware Pack	Y		Cp3-1	2	Wrapped in a non-woven bag

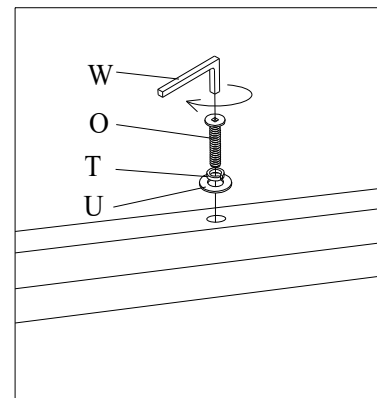
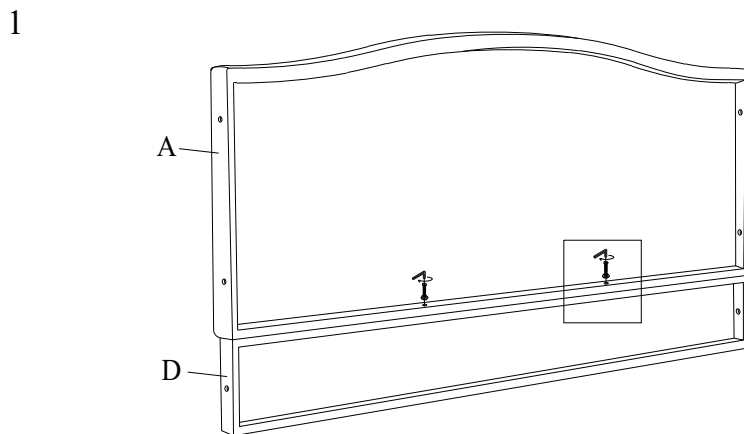
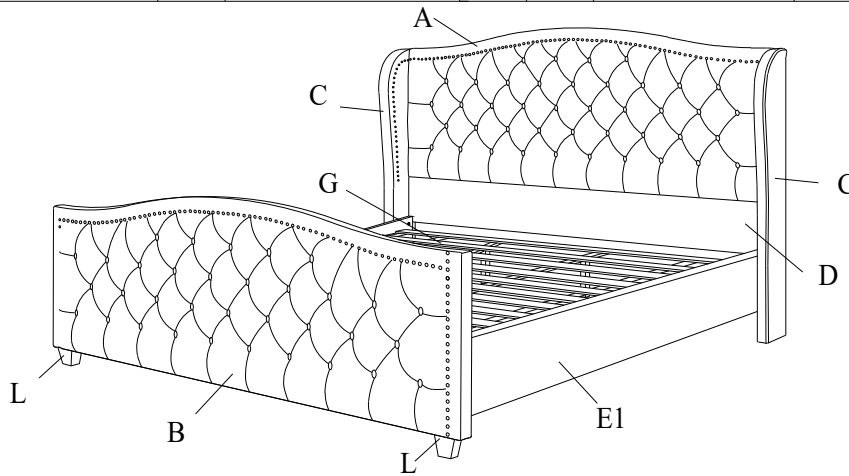

2

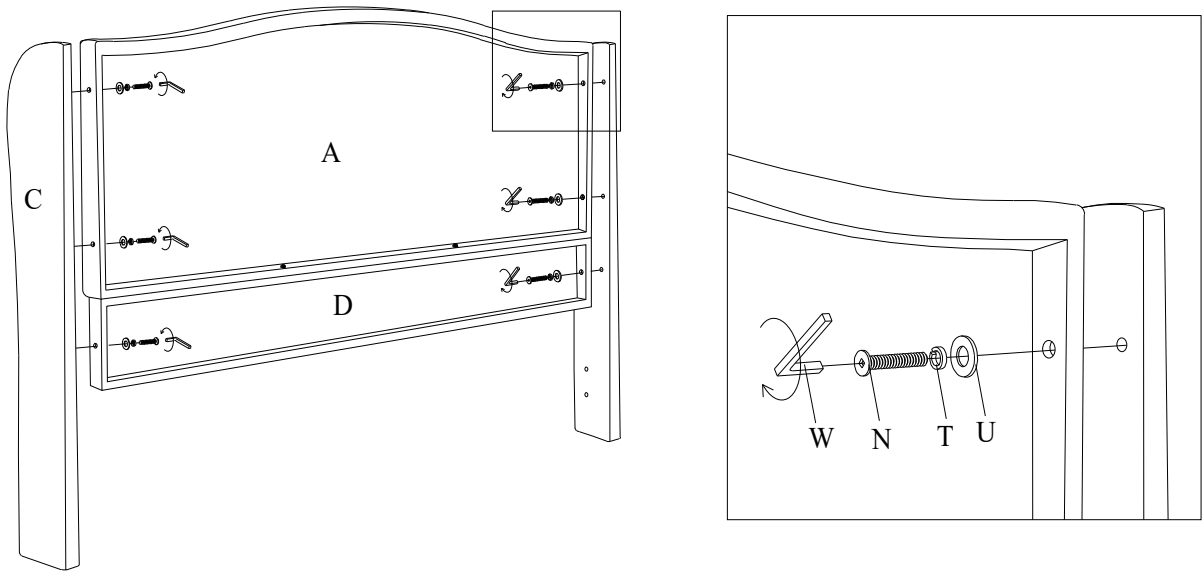

3

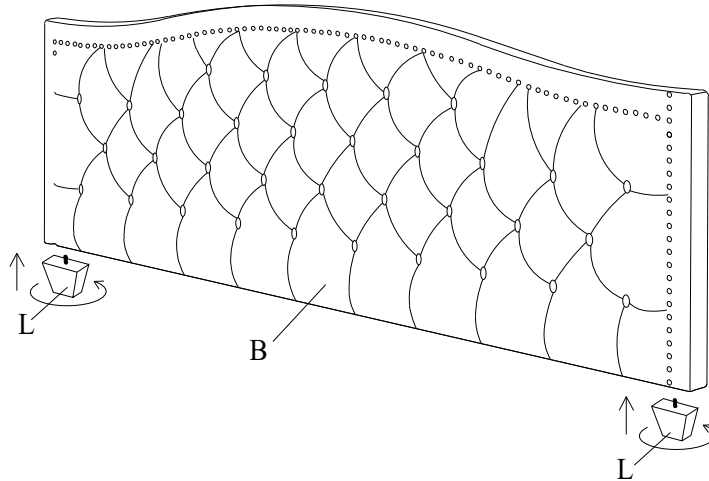

4

