

ASSEMBLY & INSTRUCTION MANUAL



OFFICE CHAIR

WARNING

Please read the instructions carefully and follow the assembly steps.

To ensure proper assembly, please follow all steps and use all parts provided. Not following this warning may result in serious injury to you or others.

To prevent misalignments, keep the screws loose and do not tighten them until they are all in their correct positions.

Avoid overtightening or forcing the screws, as this could cause them to break, strip, or damage the threads of the holes.

Using the wrong size of screws for a particular part could cause damage to the screw or the part.

Please lubricate all moving parts regularly and tighten all bolts and screws every 6 months, or as needed.

SAFETY INFORMATION

WEIGHT CAPACITY FOR SEATING: 300 LBS (≈136 KG)



Sit in the center of the chair with your back against the backrest



Do not sit at the front edge of the chair



Do not push the chair around when a person is sitting in it



Do not stand on the chair



Do not push down on the backrest when a person is reclined



Do not use the chair with more than one person



Do not place all your weight on the backrest only

ASSEMBLY PARTS AND TOOL

PLEASE MAKE SURE ALL THE PARTS ARE INCLUDED.

1



Back Cushion *1

2



Seat Cushion *1

3



Seat Plate *1

4

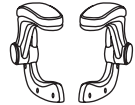

Arms*2

5

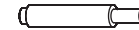

Gas Lift *1

6



Star Base *1

7



Gas Lift Cover*1

8



Casters *5

9



Bolts M6*25mm *4

10



Bolts M6*20mm *2

11



Bolts M8*25mm *8

12



Plastic Caps *8

13



Wrench *1



BEFORE YOU GET STARTED, A FEW POINTERS:



Having a friend to help makes assembly extra-easy



Please use the included wrench instead of an ELECTRIC HAND DRILL in case of damage to the product.

ASSEMBLY INSTRUCTIONS

- STEP 1** Turn the Star Base(6) upside down, then press the Casters(8) into the holes at the end of each base leg, insert the Gas Lift(5) into the center hole of the Star Base, the Gas Lift Cover(7) should be placed over the Gas Lift(5).

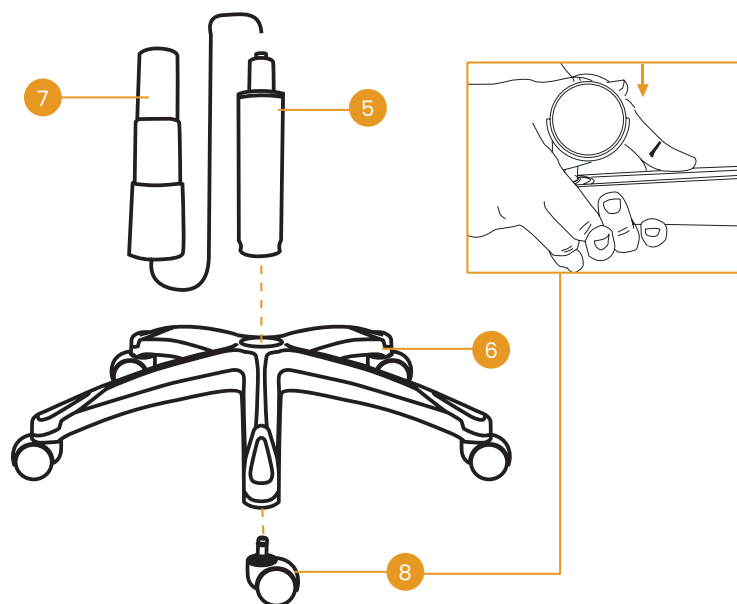

ASSEMBLY INSTRUCTIONS

- STEP 2** Align the Seat Plate(3) over the pre-drilled holes underneath the Seat Cushion(2), make sure that the front of the Seat Plate(3) is facing the front of the Seat Cushion(2). Attach the Seat Plate(3) to the Seat Cushion(2) using TWO Bolts M6*25mm(9) at the front and TWO Bolts M6*20mm(10) at the back, tighten all the bolts with the Wrench(13), being careful not to miss-thread the bolts or damage the seat.

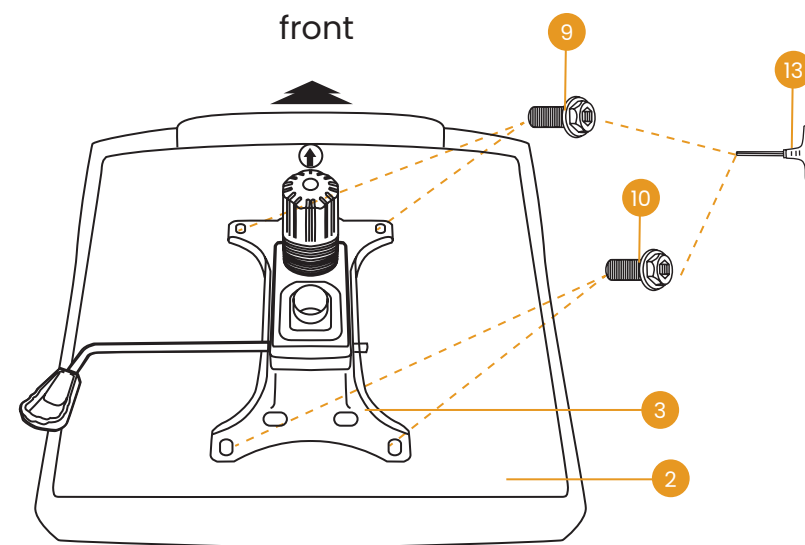

ASSEMBLY INSTRUCTIONS

- STEP 3** Turn the Seat Cushion(2) upright and align the center hole of the Seat Plate(3) over the Gas Lift(5), then push the Seat Cushion(2) down onto the Gas Lift firmly until the connection is secure.

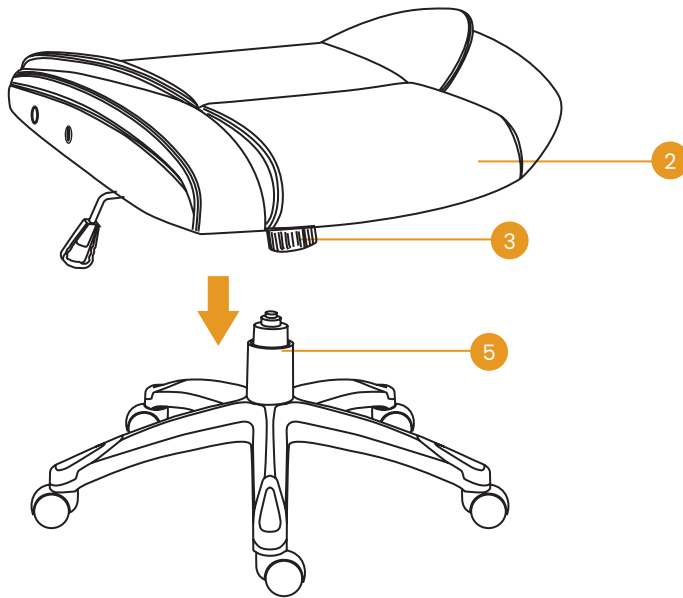

ASSEMBLY INSTRUCTIONS

- STEP 4** Attach the Arms(4) to the Seat Cushion(2) with FOUR Bolts M8*25mm(11) by using the Wrench(13).

Note 1: Arms are labeled with an "L" (left) or "R" (right) to show which sides they should be placed on.

Note 2: Do not tighten all the bolts to 100%, make sure it have space to adjust in the next steps.

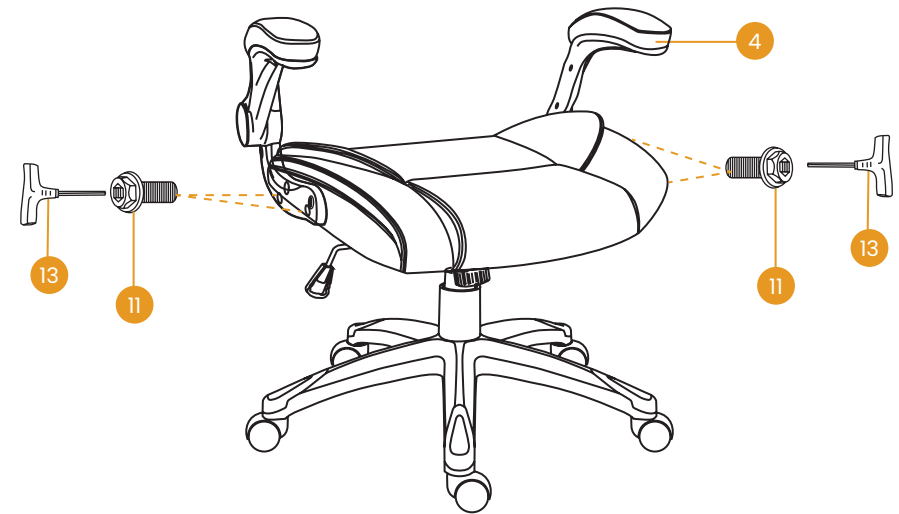

ASSEMBLY INSTRUCTIONS

STEP 5 Lay the Back Cushion(1) on the seat of the chair with the top of the cushion toward the front. Attach the Back Cushion(1) to the Arms(4) by inserting TWO Bolts M8*25mm(11) in the LOWER holes with the Wrench(13), just 50% is OK.

Note: Do not tighten all the bolts to 100%, make sure it have space to adjust in the next steps.

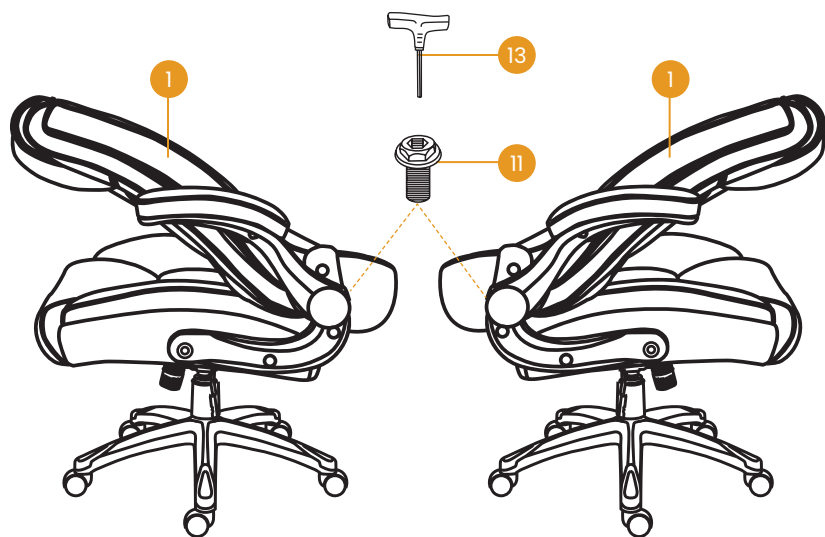

ASSEMBLY INSTRUCTIONS

STEP 6 Rotate the back of the chair up, then secure it with the TOP TWO Bolts M8*25mm(11) with the Wrench(13). Adjust the balance on each side of the chair, and fully tighten all the bolts at this step.

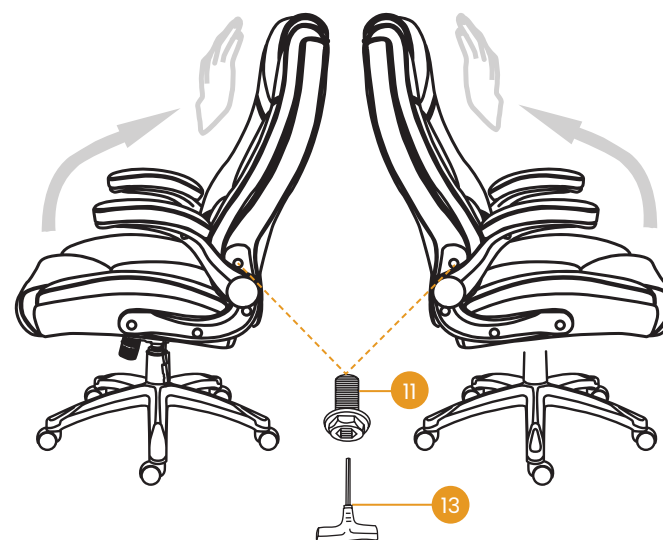

ASSEMBLY INSTRUCTIONS

- STEP 7** Align the control handles of the back adjust over the pre-drilled holes underneath the Seat Cushion(2), attach the handle to the Seat Cushion(2) using TWO Bolts M6*25mm(9), tighten all the bolts with the Wrench(13).

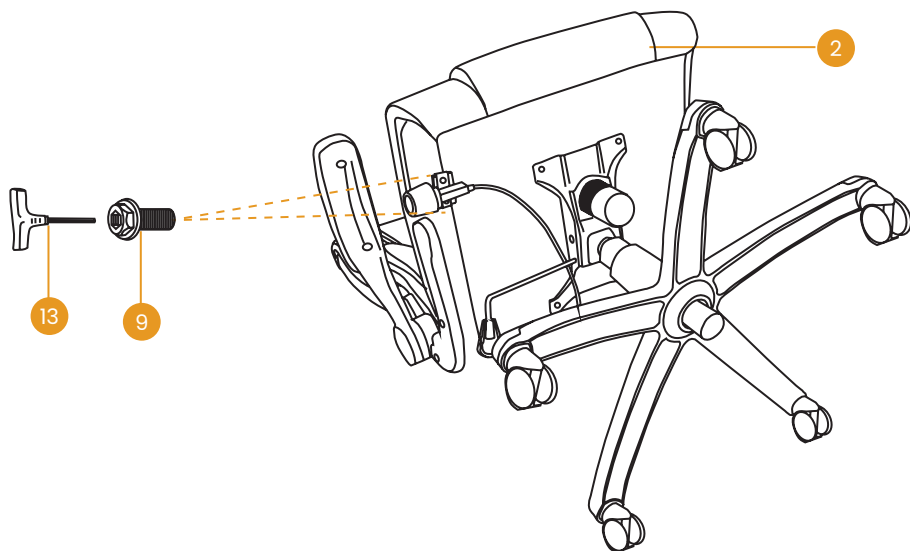

ASSEMBLY INSTRUCTIONS

- STEP 8** Use the Plastic Caps(12) to cover the bolt holes on the arms. Now, your chair is successfully installed.



PRODUCT FEATURES

Pneumatic Seat Height Adjustment

Pulling the lever upwards enables height adjustment of the seat, then the seat can be locked at a fixed height by releasing the lever.



Rock Tension Adjustment

Simply adjust the knob counterclockwise to tighten the tension of rocking. Or loosen the tension by turning the knob clockwise whenever needed.

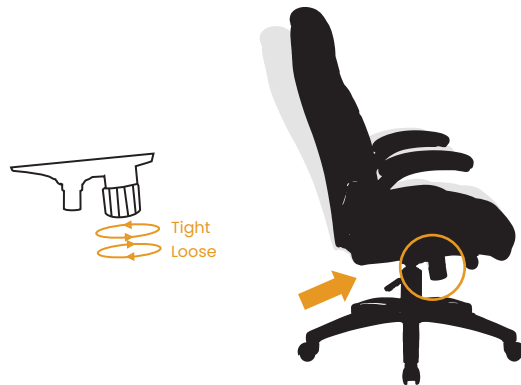

PRODUCT FEATURES

Seat Back Locking Mechanism

Simply press the lever down to lock the seat in an upright position.

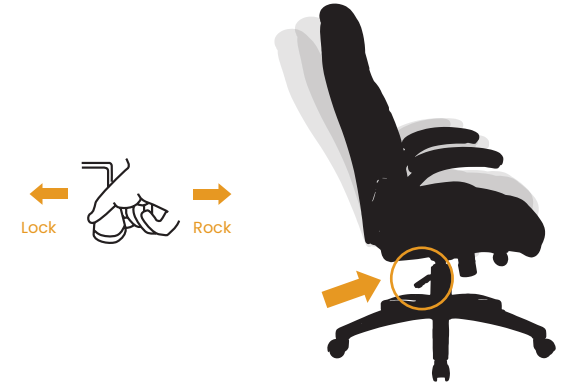

Back Support Adjustment

Simply turn the knob clockwise to protrude the back cushion, otherwise, it will retract the back cushion.



LIMITED WARRANTY

We promise to repair or replace any chair that is found to be defective in material or workmanship within one year from the date of original purchase, as long as you, the original purchaser, still own it. This is your sole and exclusive remedy under this warranty, subject to the provisions outlined below.

EXCLUSIONS

This warranty does not apply to, and no other warranty applies to:

- Normal wear and tear, which is to be expected over the course of ownership.
- Misuse, abuse, or excessive use of the product.
- Modifications or attachments to the product that are not approved.
- Products that were not installed, used, or maintained in accordance with the product instructions and warnings.
- Products used for rental purposes or unauthorized retail activities.

Seating Usage: Normal use for seating is defined as equivalent to a single shift, forty-hour (40) workweek. If the seating product is used in a manner exceeding this, the applicable warranty period will be proportionately reduced.

RETURN POLICY

We offer a 30-day return policy, meaning that all products purchased may be returned to us within that timeframe. You must contact us via email or customer service phone number within 30 days of receiving the product(s), and they must be returned to us without any undue delays.

CONDITIONS:

- Returned products must be in the same condition as received and returned in their original packaging.
- If the product is not faulty (i.e., if you change your mind or are unhappy with the product for another reason), you are responsible for the cost of return shipping. You must ensure the package arrives safely to us, so we recommend using a courier service that offers tracking.

LIMITED WARRANTY

- If the product is faulty when received, please contact us, and we will assist you with the return, covering the shipping costs in this case.
- We reserve the right to offer partial refunds for returned products that are not in unused condition, are damaged, or have missing parts not due to our error.

HOW RETURNS WORK

To request a return, please attach a copy of your invoice as proof of purchase, along with the reason for the return.

We will provide the return address for the product as soon as possible. Once the returned product is received and inspected, we will provide a specific resolution.

If the return is approved, the refund amount will be automatically credited to your original payment method.

MAINTENANCE INSTRUCTIONS

Dust and clean up spills immediately using a clean, non-colored, lint-free cloth.



Use a mild soap solution and a damp cloth to remove stains.



Do not place hot items directly on the furniture surface without using a protective barrier.



For indoor use only. Do not place the furniture outside.



Do not place furniture in direct sunlight.



Do not write on the furniture surface without a padded barrier to protect it.



Do not clean furniture with harsh cleaners or polishes.



Do not place furniture near heating or cooling vents (keep at least 3 feet away)