

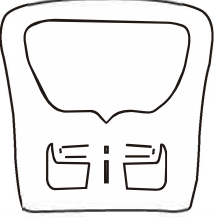

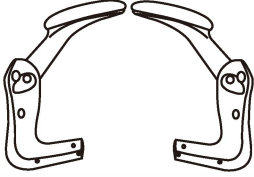



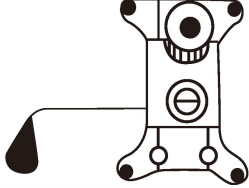

Assembly Instruction

PARTS	
A×1 	C×1 
B×1 	D×1 
E×1 	F×1 
G×5 	H×1 a  ×8 6*22mm c  ×4 6*45mm
I×1 	J×1 
K×4 	

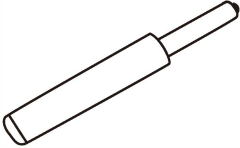
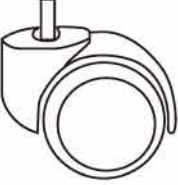
STEP 1

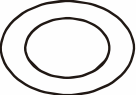
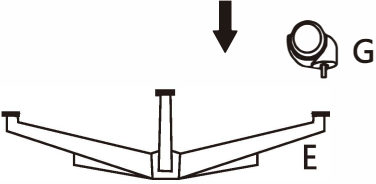

Push the wheels to the base.

STEP 2

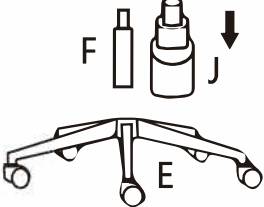

Put the gas lift on the base. Then put the plastic cover.

STEP 3

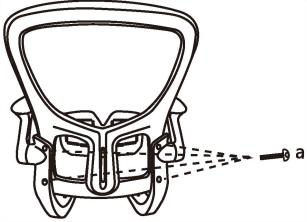

NOTE: Please assemble the armrests and backrest firstly.

STEP 4

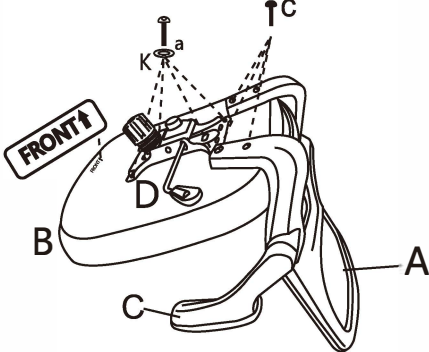

Attach the seat control on the seat cushion. Please notice the direction!
Assemble the seat cushion and backrest.

STEP 5



Assemble the chair with two whole parts.

STEP 6

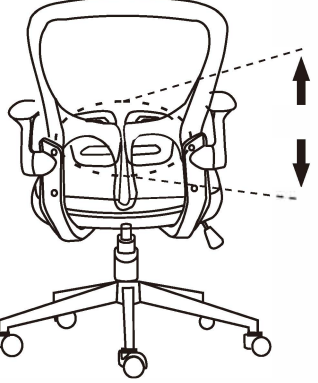

The middle part of the circle can be adjusted up and down