

# ASSEMBLY INSTRUCTION

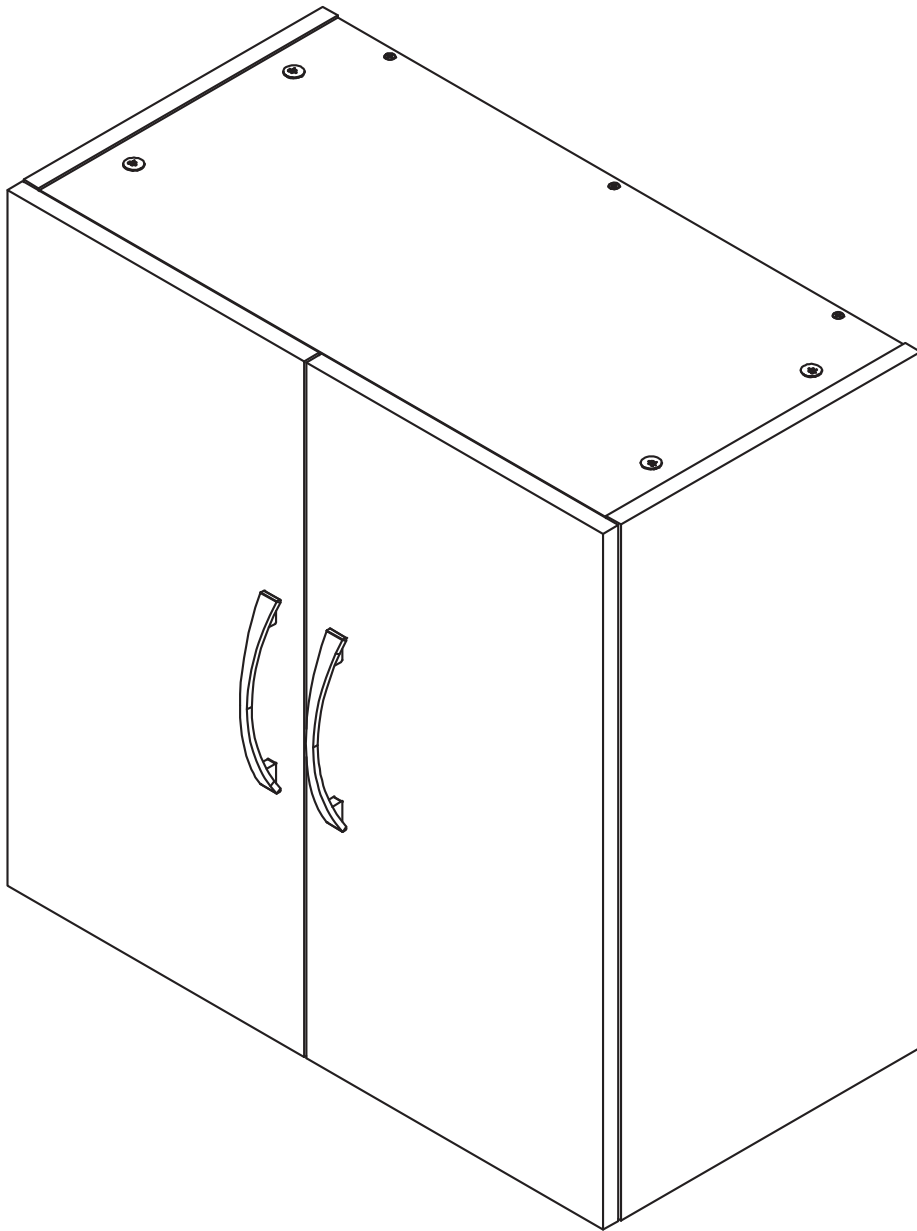

# INSTALLATION PREPARATION

Dear Customer,

Thank you for choosing us. Before you begin assembly, check that you have all the parts and hardware shown on this page.

If there is any item missing, please mark the item, indicating quantity required and send picture to us. We will arrange replacement at first time.

**If feel question in assemble, Please feel free to ask us. Customer satisfaction is our prime.**

Your order means a lot to us!

Thank you!

## TOOLS NEEDED

Crosshead screwdriver

Flat-head screwdriver



## PARTS LIST

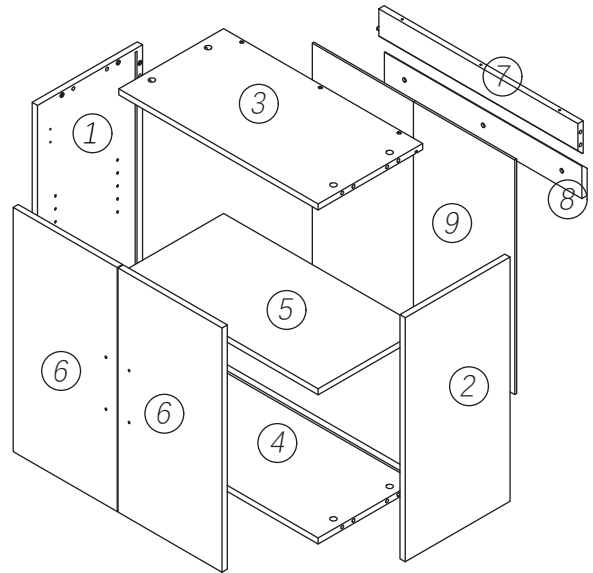

## HARDWARE LIST

**A:**Cam lock  
Φ15mm



10 PCS

**B:**Cam bolt  
M6



10 PCS

**C:**Wooden Dowel  
Φ8\*30mm



10 PCS

**D:**Full cover hinge

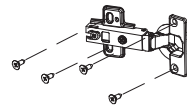

4 PCS

**E:**Handle  
3617



2PCS

**F:**Screw(ST4\*18)



4 PCS

**G:**Screw  
M5\*40mm



3 PCS

**H:**Expansion screw  
8\*80mm



3 PCS

**I:**Shelf support



4 PCS

**J:**Plug (low)  
Φ15mm



10 PCS

## STEP 01

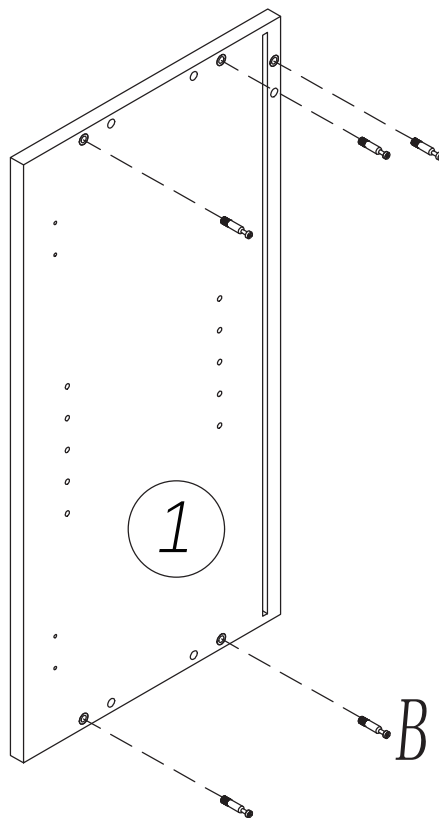

B×5

## STEP 02

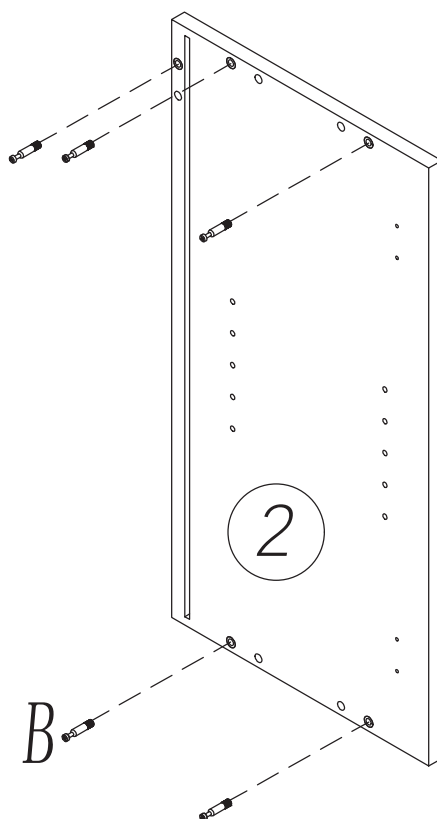

B×5

## STEP 03

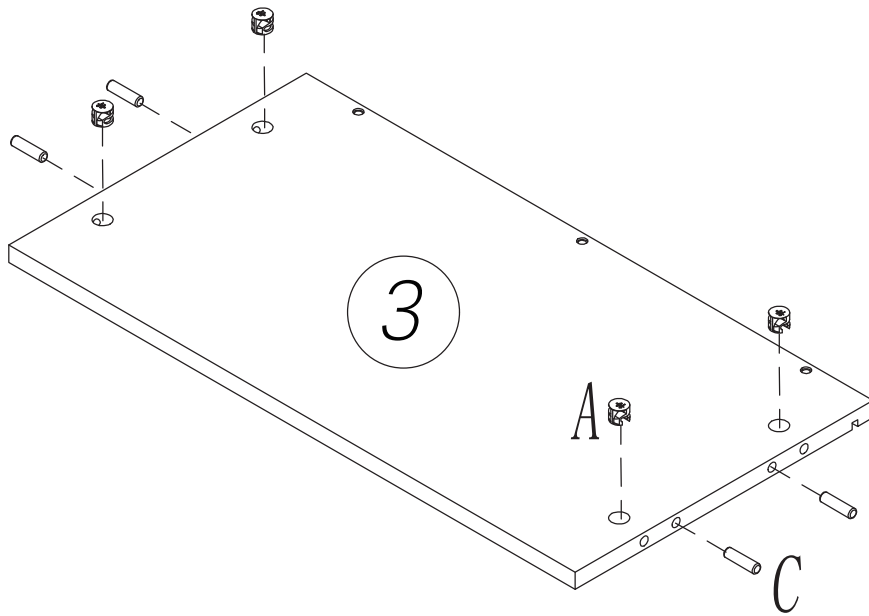

Direction of arrow to the side hole

## STEP 04

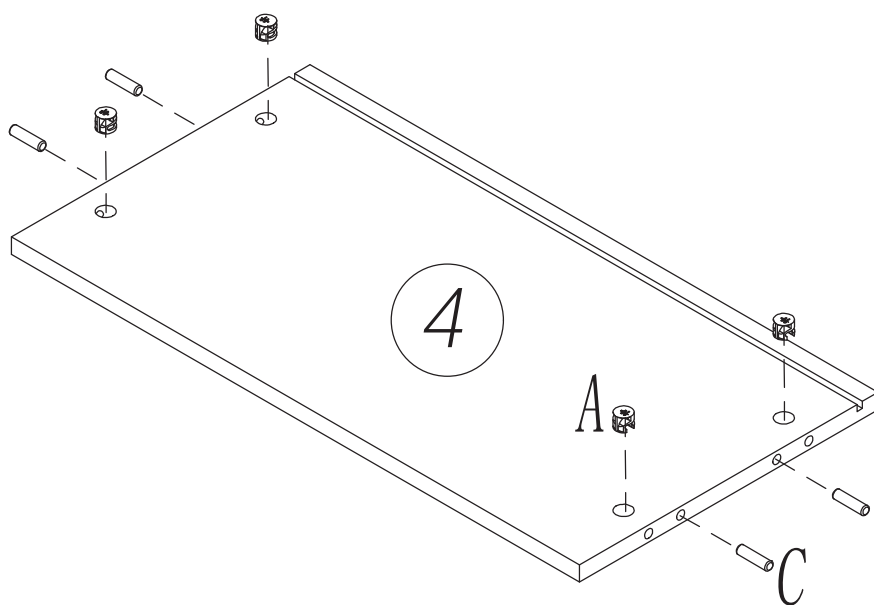

Direction of arrow to the side hole

## STEP 05

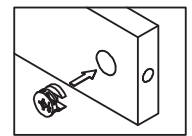
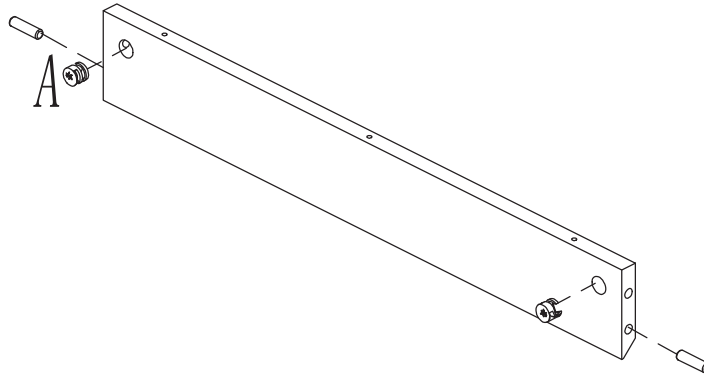

Direction of arrow to the side hole

## STEP 06

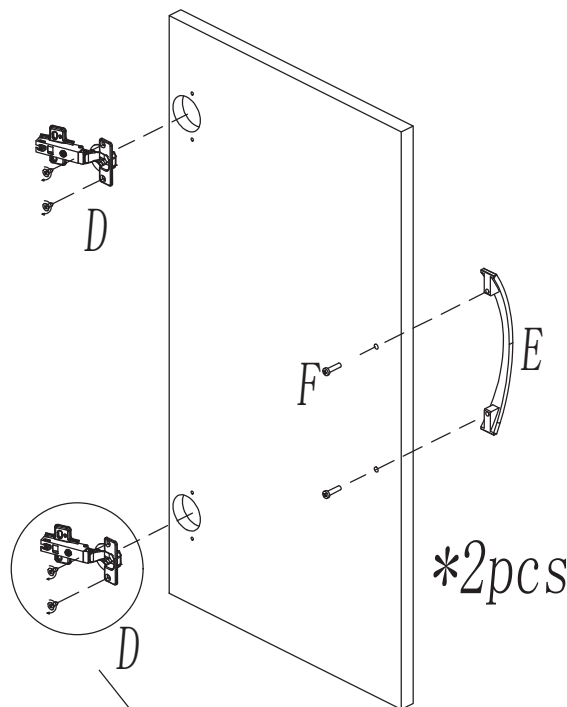
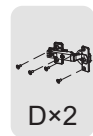

Note: Extra screws to lock cabinets;

## STEP 07

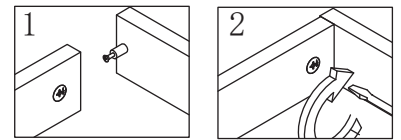
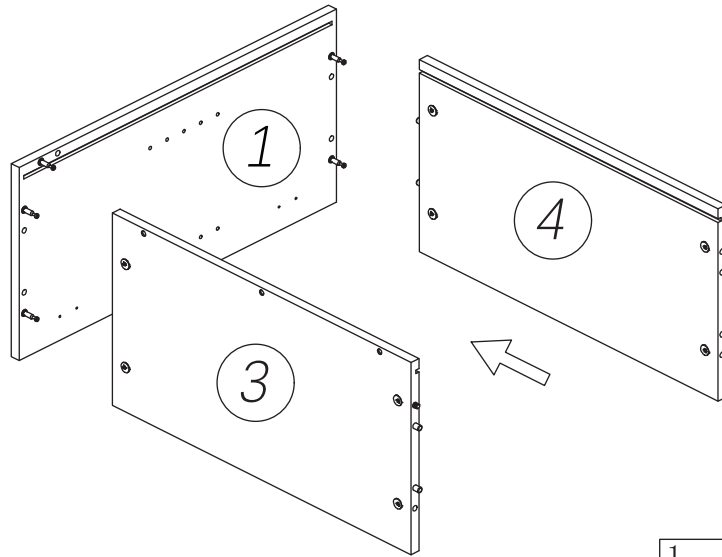

Remember to lock the Cam Lock

## STEP 08

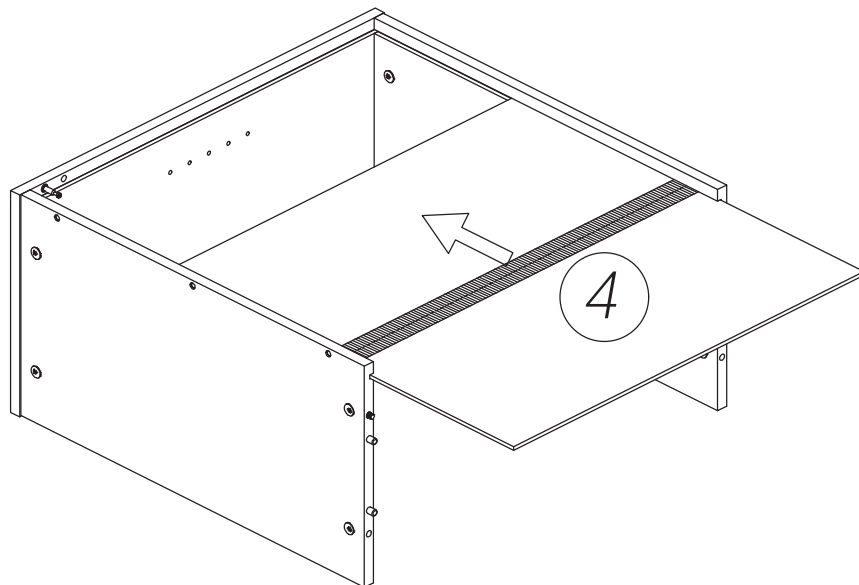

STEP 09

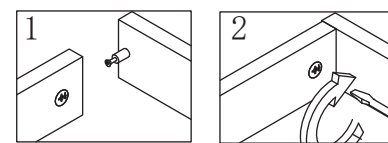
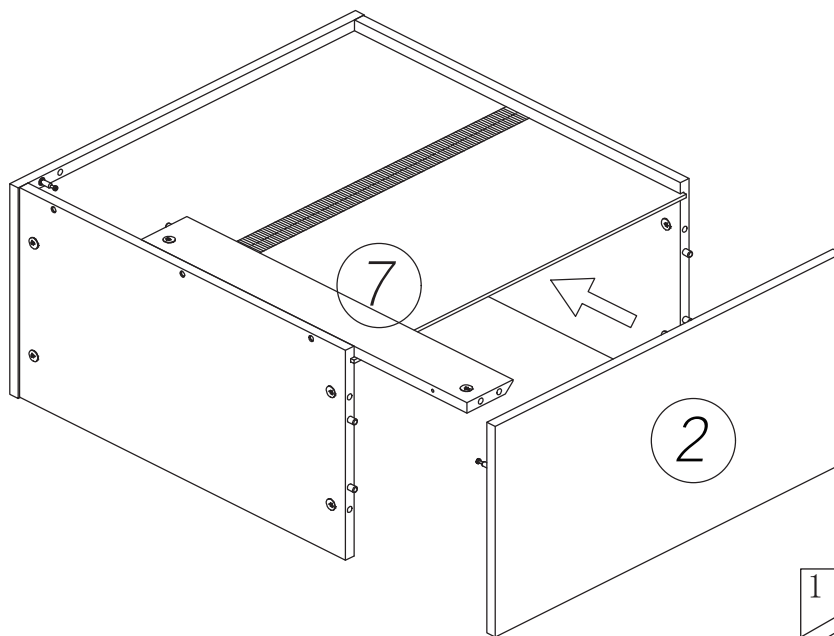

Remember to lock the Cam Lock

STEP 10

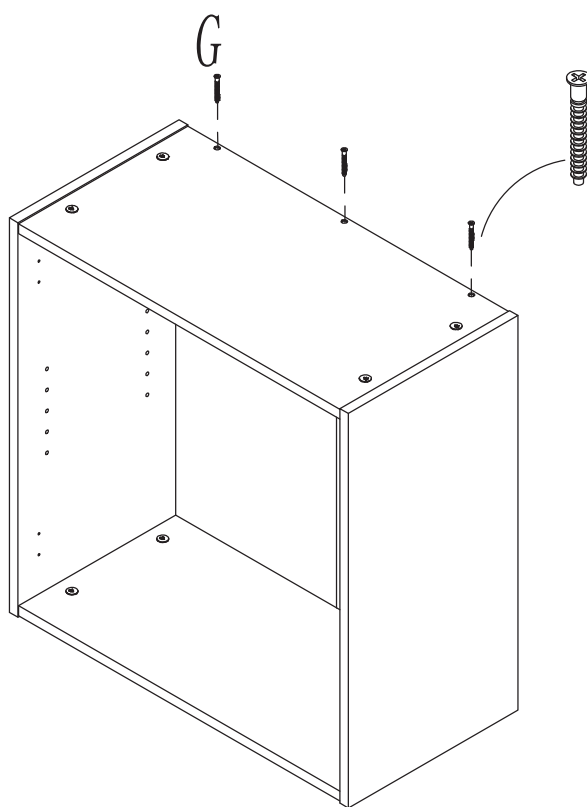

## STEP 11

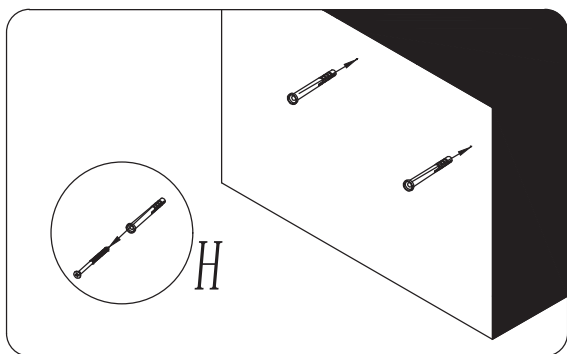
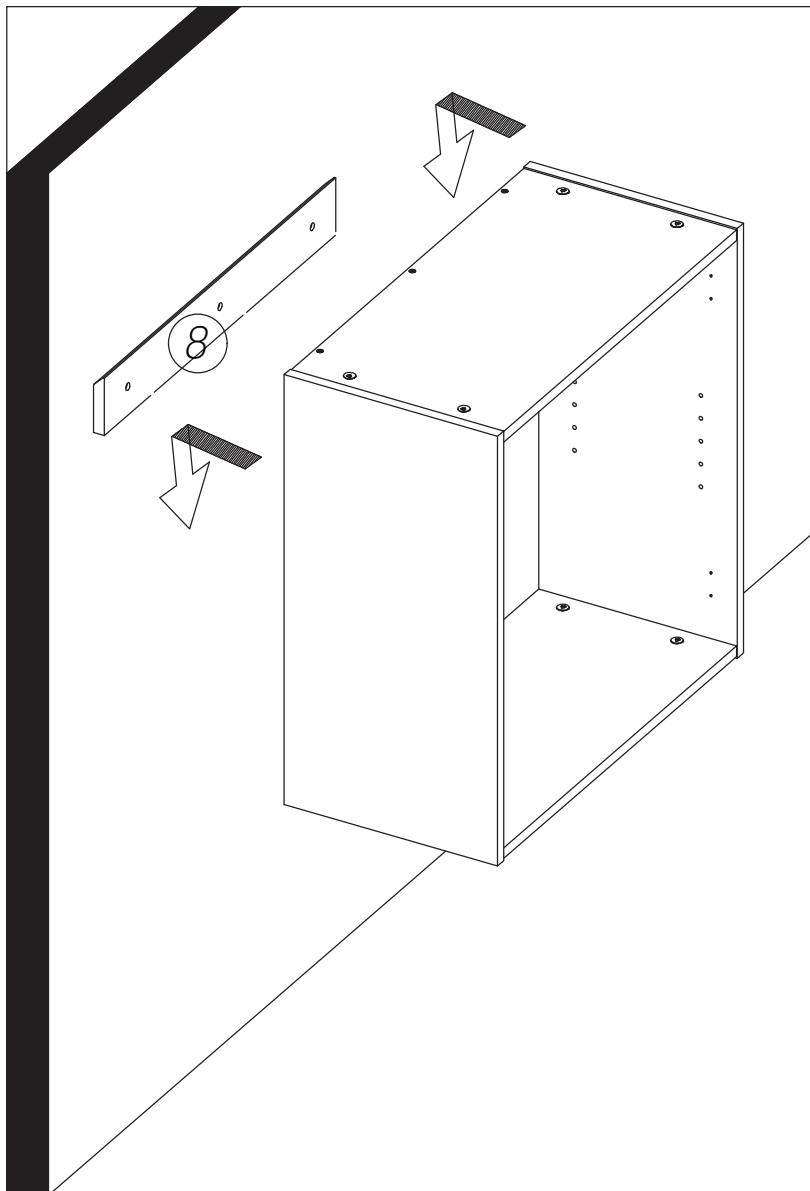

First of all, remove the screw of the expansion tube, and then drive the expansion tube in the position of the drilled hole in the wall.

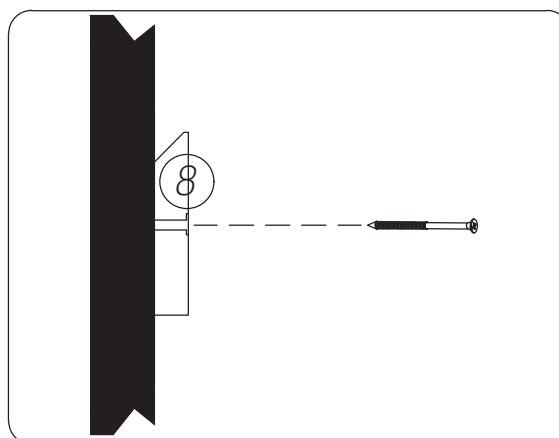

# INSTALLATION PREPARATION

If there is misalignment after you install, adjust the screw to the best condition.

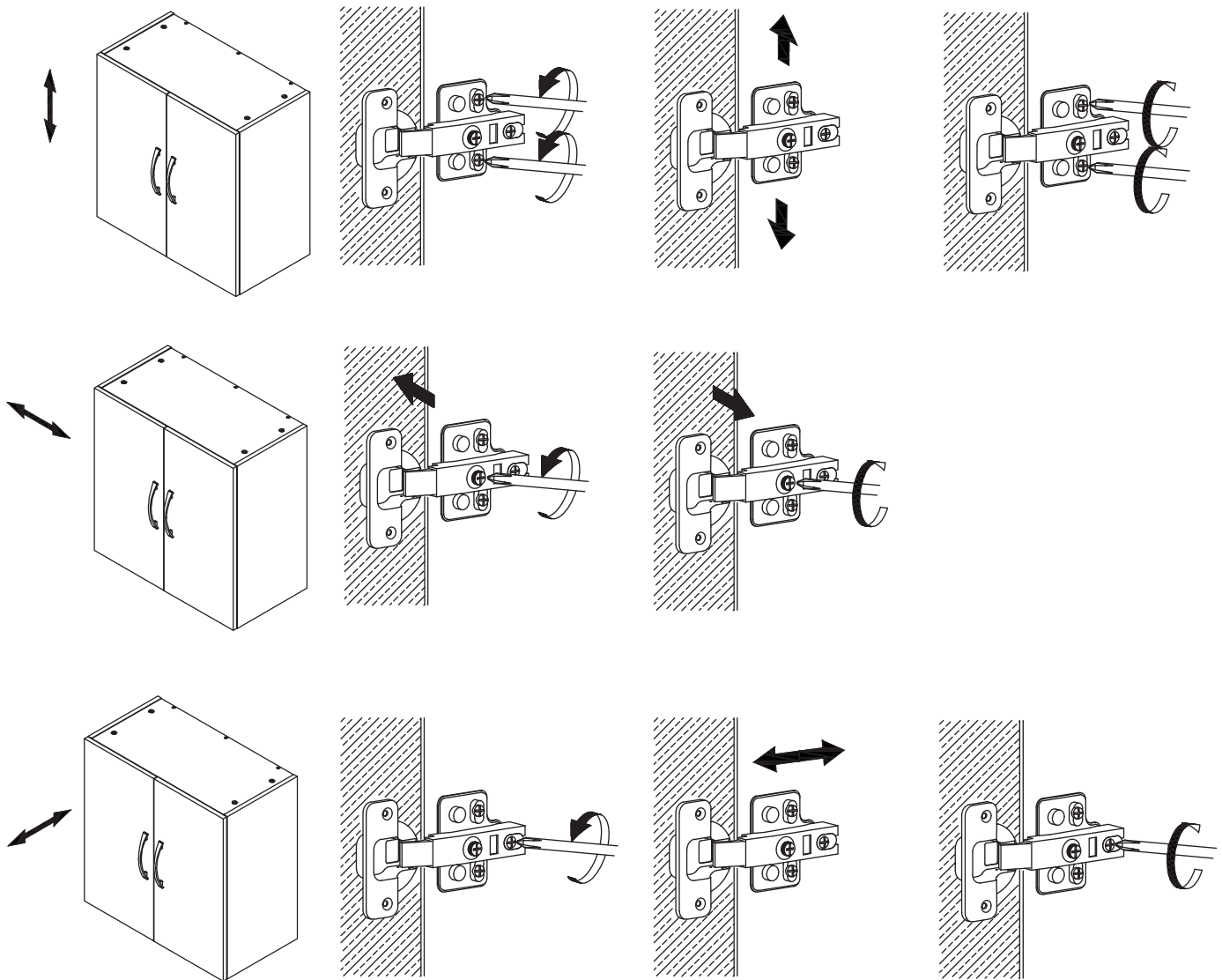

Thank you for your recent order.

We strive to provide customers with great services and satisfaction.

If any questions, please contact us.

Our customer support team is ready to help!