

ASSEMBLY INSTRUCTIONS





Item No : D1750-20







Thea Wood Back Side Chair
(2 PCS PER CARTON)

Thank you for purchasing this quality product. Be sure to check all packing materials carefully for small parts, which may have come loose inside the carton during shipment. Identify and count all items and compare with the parts list and/or hardware list shown below.

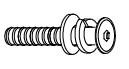
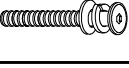
IMPORTANT NOTE :

- * PLACE ALL WOODEN PARTS ON A CLEAN AND SMOOTH SURFACE SUCH AS A RUG OR CARPET TO AVOID THE PARTS FROM BEING SCRATCHED.
- * PLEASE DO NOT OVERTIGHTEN THE SCREWS TO AVOID CRACKING THE PARTS.
- * BEFORE YOU BEGIN, KINDLY REVIEW THE ASSEMBLY INSTRUCTIONS AND FOLLOW STEP BY STEP.
- * KEEP ALL HARDWARE PARTS OUT OF REACH OF CHILDREN.

PARTS LIST			
NO	DESCRIPTION	SKETCH	QTY
A	Stretcher		4 Pcs
B	Left Side Facing (LSF) Frame L		2 Pcs
C	Right Side Facing (RSF) Frame R		2 Pcs
D	Chair Back		2 Pcs
E	Cushion Seat		2 Pcs

HARDWARE LIST			
NO	DESCRIPTION	SKETCH	QTY
1	JCBC Bolt M6 x 1 1/8" w/ Spring Washer M6 and Flat Washer M6 x 4/8"		8 Pcs
2	JCBC Bolt M6 x 2" w/ Spring Washer M6 and Flat Washer M6 x 4/8"		8 Pcs
3	Allen Key M4		1 Pc
4	L Bracket		8 Pcs
5	PH Screw M4 x 4/8"		16 Pcs
6	Wood Dowel M8 x 1"		4 Pcs
7	Wood Button 9/16"		8 Pcs

STEP 1 : Install Stretcher (A) between LSF Frame (B) and RSF Frame (C) by align the pieces into the designated holes of the frames.

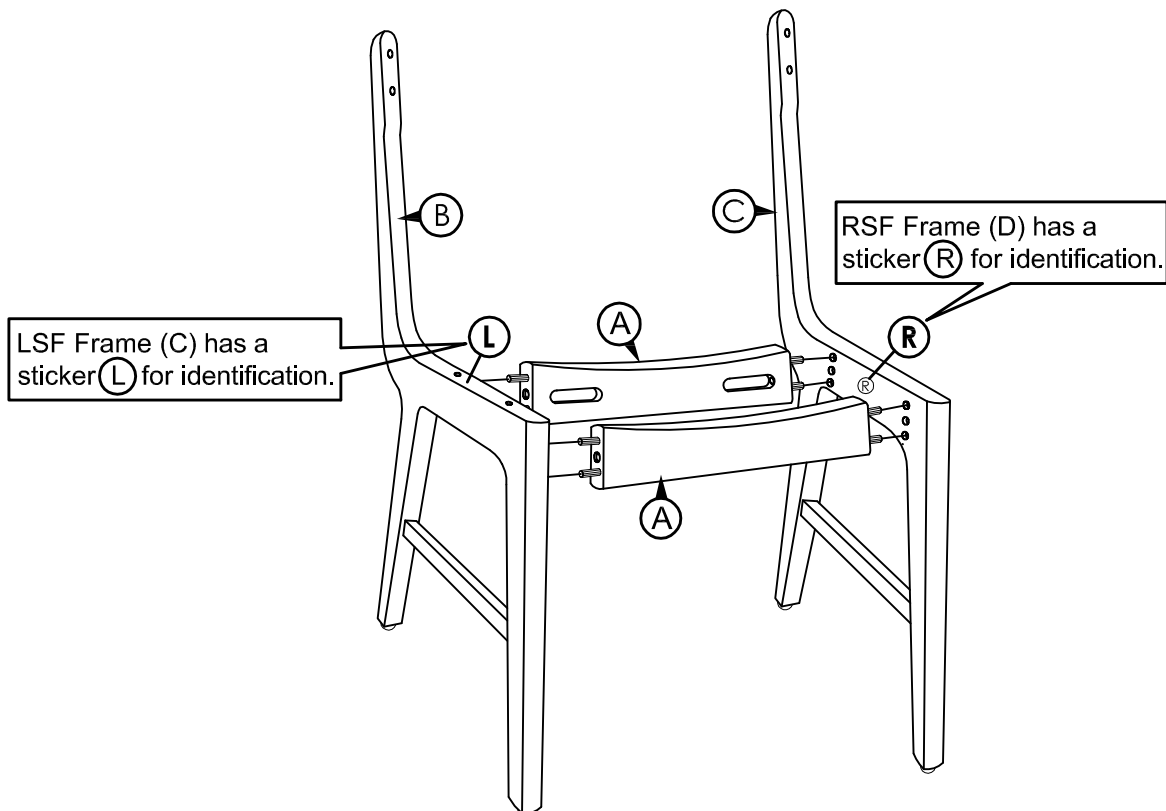

STEP 2 : Assemble only the Stretcher (A) to the LSF and RSF Frame (B & C) by using Allen Key (3) with the hardware (2).

***DO NOT FULLY TIGHTEN THE BOLTS.**

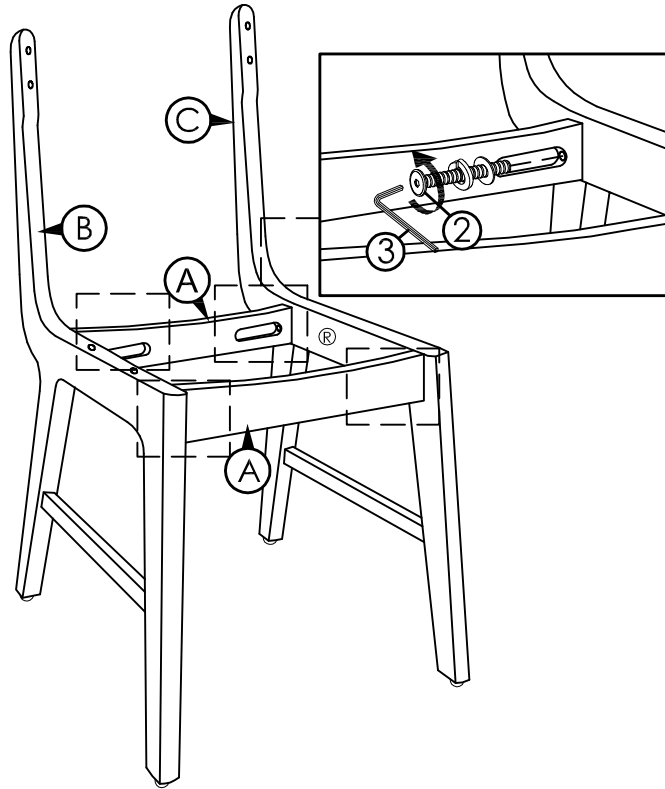

STEP 3 : Assemble the Chair Back (D) to the top of the assembled chair frame by using the Allen Key (3) with the hardware (1).

***DO NOT OVERTIGHTEN THE BOLTS.**

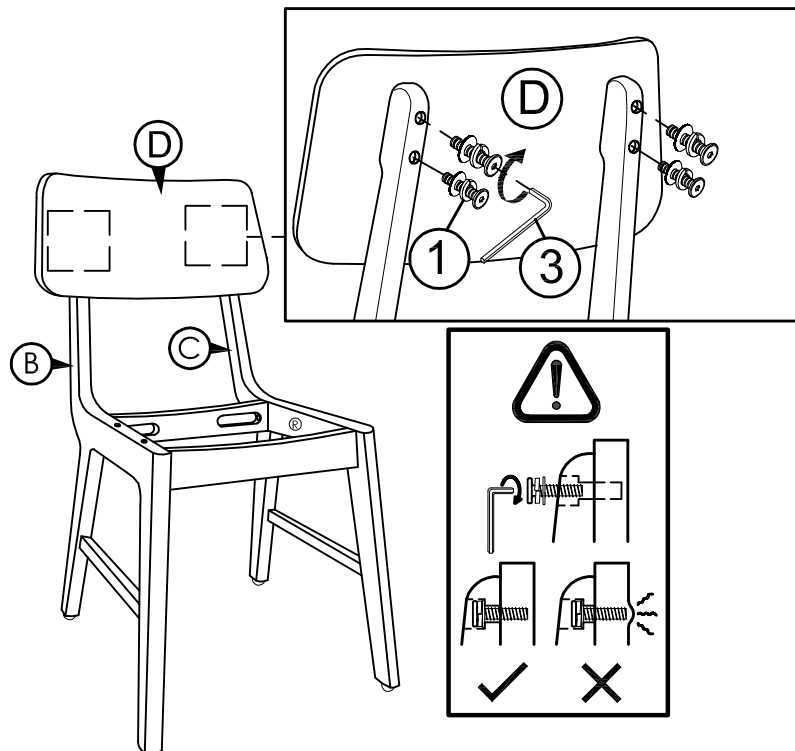

STEP 4 : To conceal the screw holes on the back of the chair frames (B & C), install the Wood Button (7) by using a wood mallet and lightly tap into each screw hole.

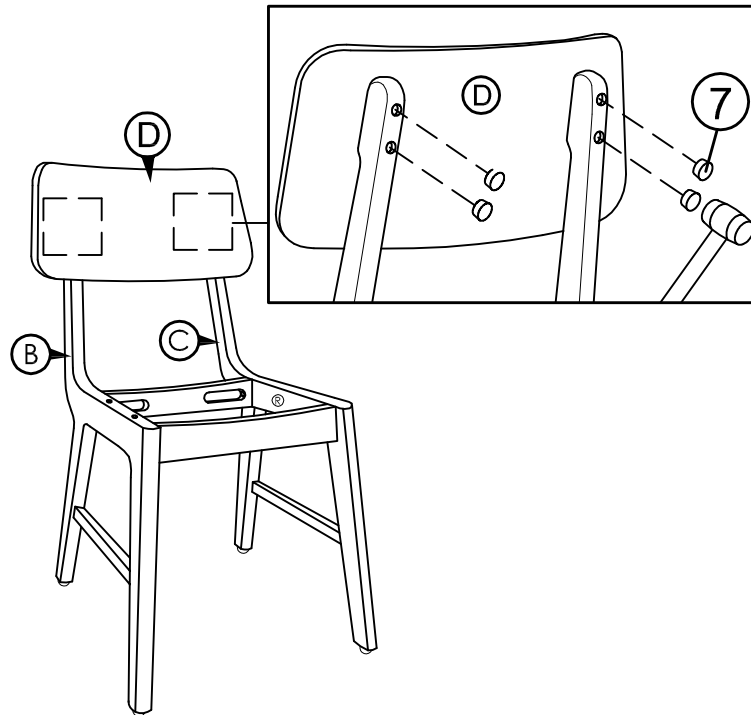

STEP 5 : To level the chair, place the chair on a flat surface and tighten all the bolts using Allen Key (3).

***DO NOT OVERTIGHTEN THE BOLTS.**

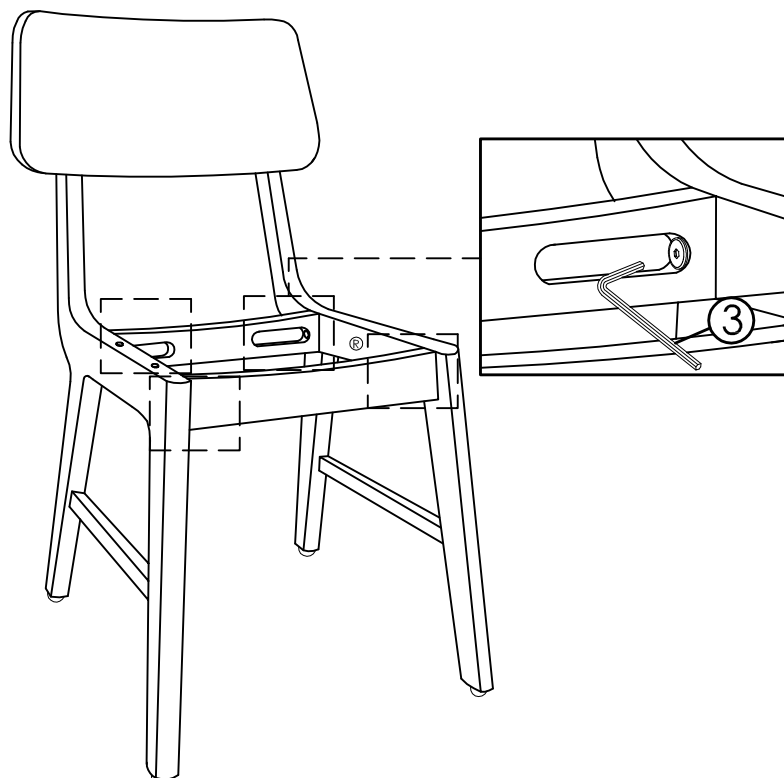

STEP 6 : Insert Wood Dowel (6) into the designated hole on LSF Frame (B).

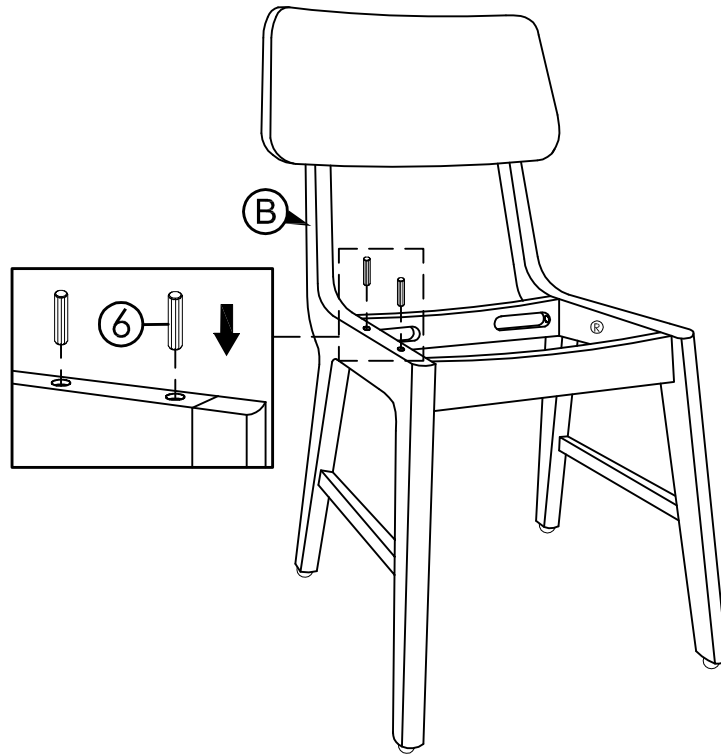

STEP 7 : Place the Cushion Seat (E) upside down on a elevated surface (ex. Table top). Then, place the chair frame upside down and push the wood dowels (6) on the LSF Frame (B) into the holes on the bottom Cushion Seat (E).

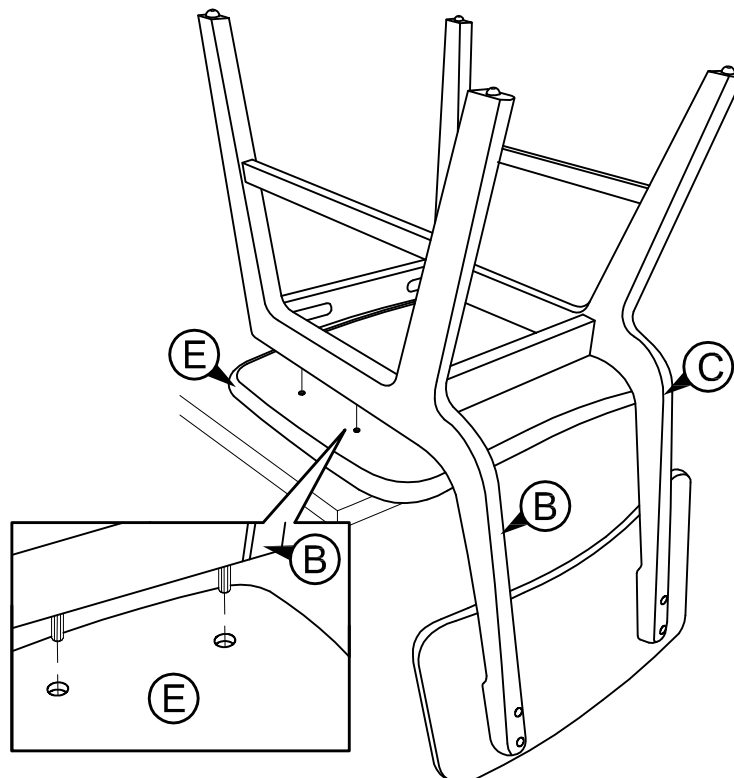

STEP 8 : Assemble the chair frames (B&C) to the Cushion Seat (E) by using a screwdriver with hardware (4) & (5).

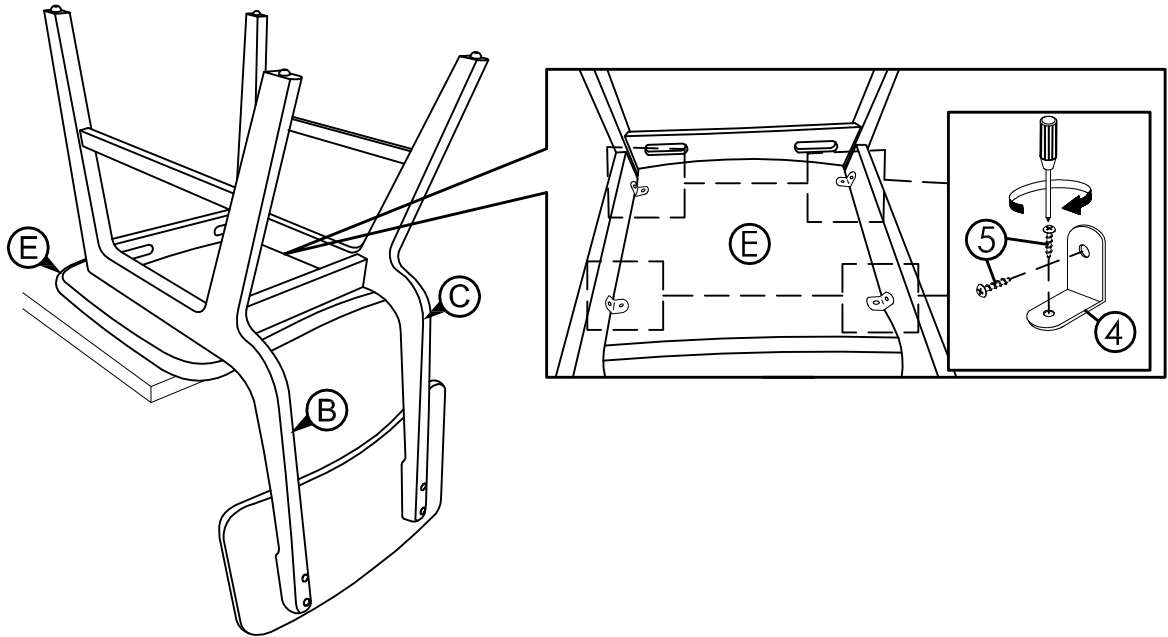

STEP 9 : Place the chair right side up and the assembly is complete.

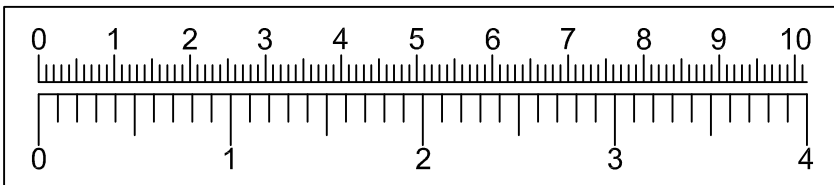
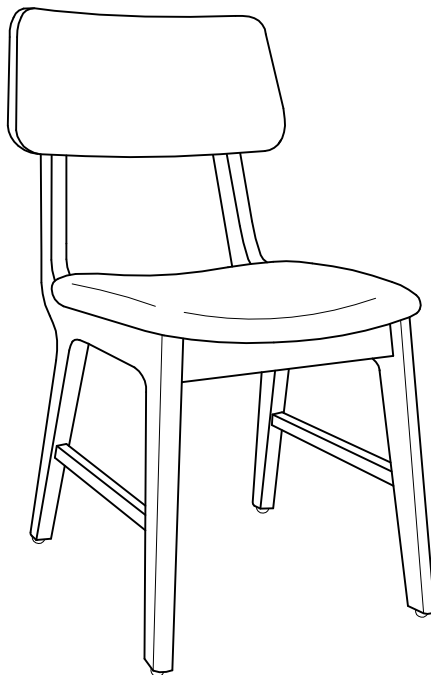





ASSEMBLY INSTRUCTIONS



Item No : D1750-10
Thea 70" Rectangular Dining Table

Thank you for purchasing this quality product. Be sure to check all packing materials carefully for small parts, which may have come loose inside the carton during shipment. Identify and count all items and compare with the parts list and/or hardware list shown below.

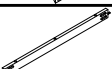
IMPORTANT NOTE :

- * PLACE ALL WOODEN PARTS ON A CLEAN AND SMOOTH SURFACE SUCH AS A RUG OR CARPET TO AVOID THE PARTS FROM BEING SCRATCHED.
- * PLEASE DO NOT OVERTIGHTEN THE SCREWS TO AVOID CRACKING THE PARTS.
- * BEFORE YOU BEGIN, KINDLY REVIEW THE ASSEMBLY INSTRUCTIONS AND FOLLOW STEP BY STEP.
- * KEEP ALL HARDWARE PARTS OUT OF REACH OF CHILDREN.

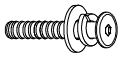
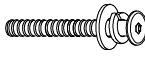
PARTS LIST			
NO	DESCRIPTION	SKETCH	QTY
A	Table Top		1 Pc
B	Table Leg		2 Pcs
C	Long Apron		2 Pcs
D	Leg Stretcher		1 Pc

HARDWARE LIST			
NO	DESCRIPTION	SKETCH	QTY
1	JCBC Bolt M6 x 1 6/8" w/ Spring Washer M6 and Flat Washer M6 x 4/8"		12 Pcs
2	JCBC Bolt M6 x 2 3/8" w/ Spring Washer M6 and Flat Washer M6 x 4/8"		6 Pcs
3	Allen Key M4		1 Pc

STEP 1 : Place the Table Top (A) upside down on a soft and clean surface. Then, align Long Apron (C) through the holes on (A). Then, insert hardware (2) and tighten by using Allen Key (3).
*DO NOT FULLY TIGHTEN THE BOLTS

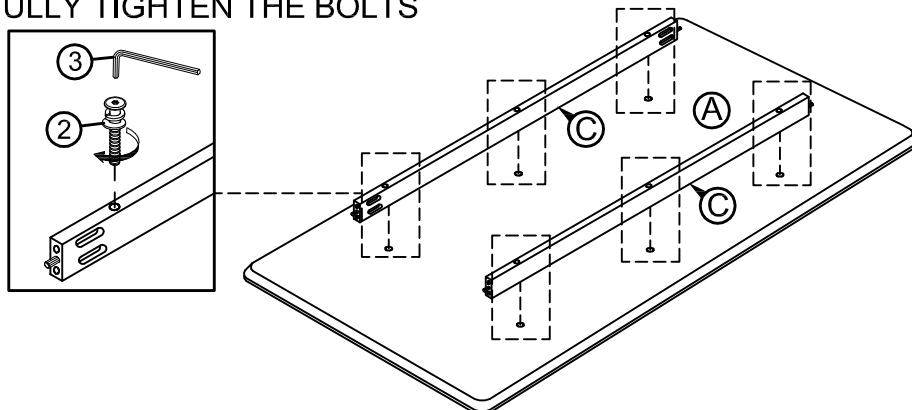

STEP 2 : Install Table Leg (B) through pre-installed wood dowels at Long Apron (C). Then, assemble (C) to Table Leg (B) by using Allen Key (3) with the hardware (1).
*DO NOT FULLY TIGHTEN THE BOLTS.

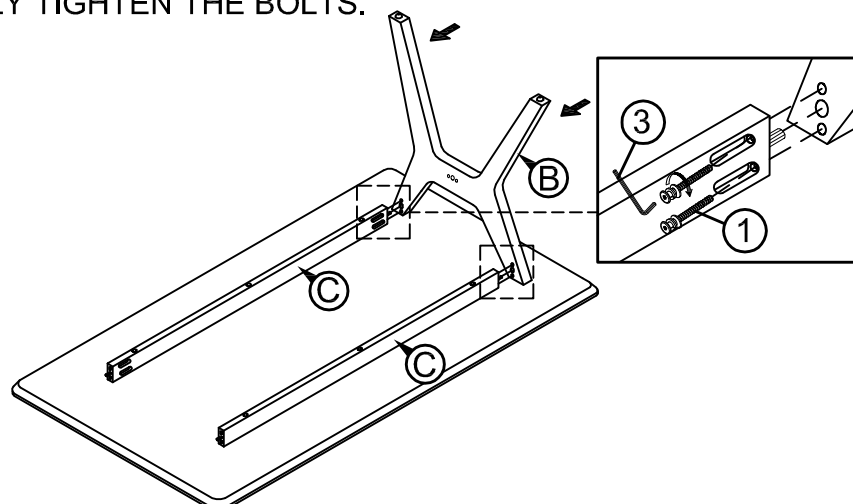

STEP 3 : Install Leg Stretcher (D) by align the holes on Table Leg (B) and tighten by using Allen Key (3) with hardware (1).

***DO NOT FULLY TIGHTEN THE BOLTS.**

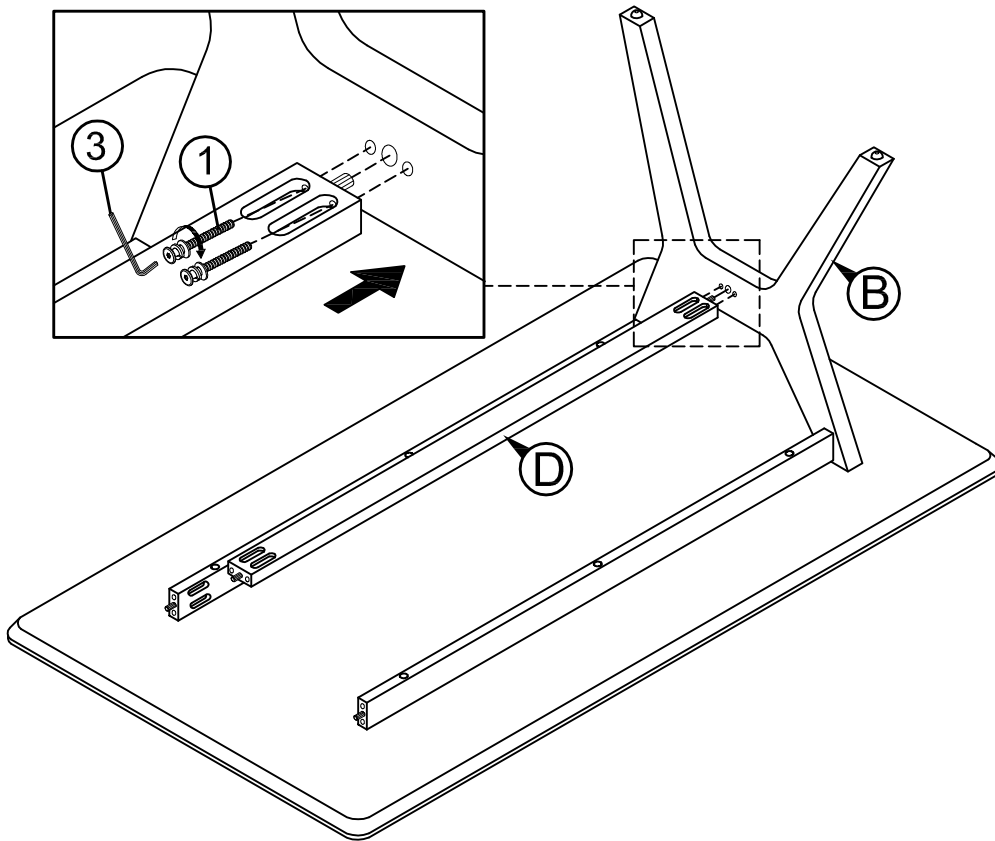

STEP 4 : Install another Table Leg (B) Stretcher through pre-installed wood dowels at Long Apron (C) and Leg Stretcher (D). Then, assemble (D) to Table Leg (B) by using Allen Key (3) with hardware (1).

***DO NOT FULLY TIGHTEN THE BOLTS.**

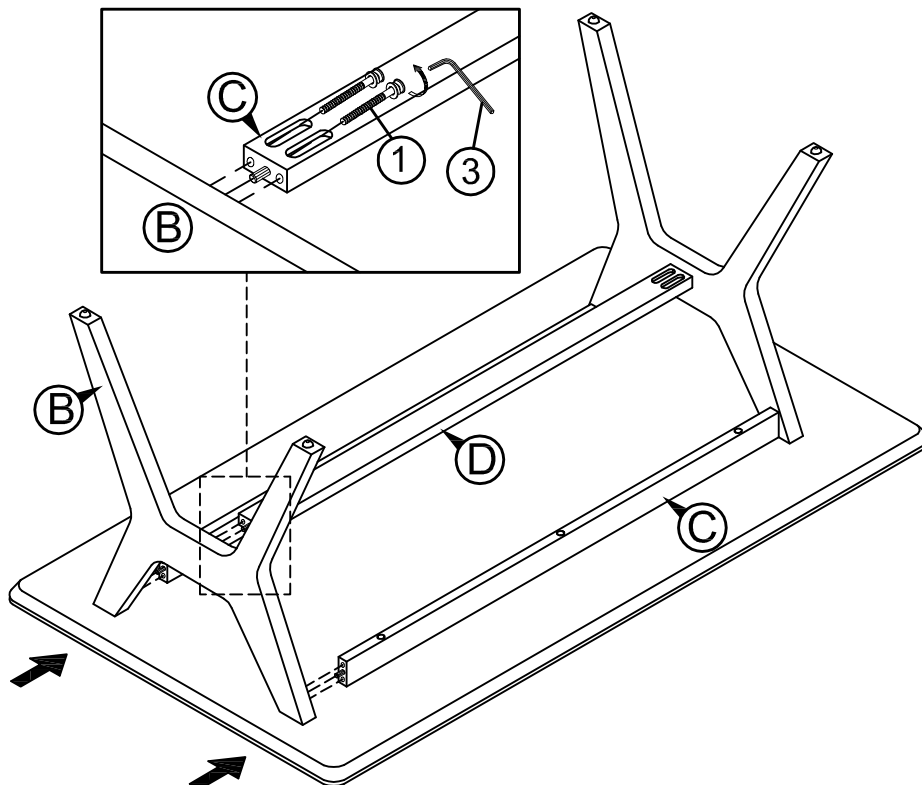

STEP 5 : Assemble Long Apron (C) to Table Leg (B) by using Allen Key (3) with the hardware (1).
*PLEASE FULLY TIGHTEN THE BOLT NOW.

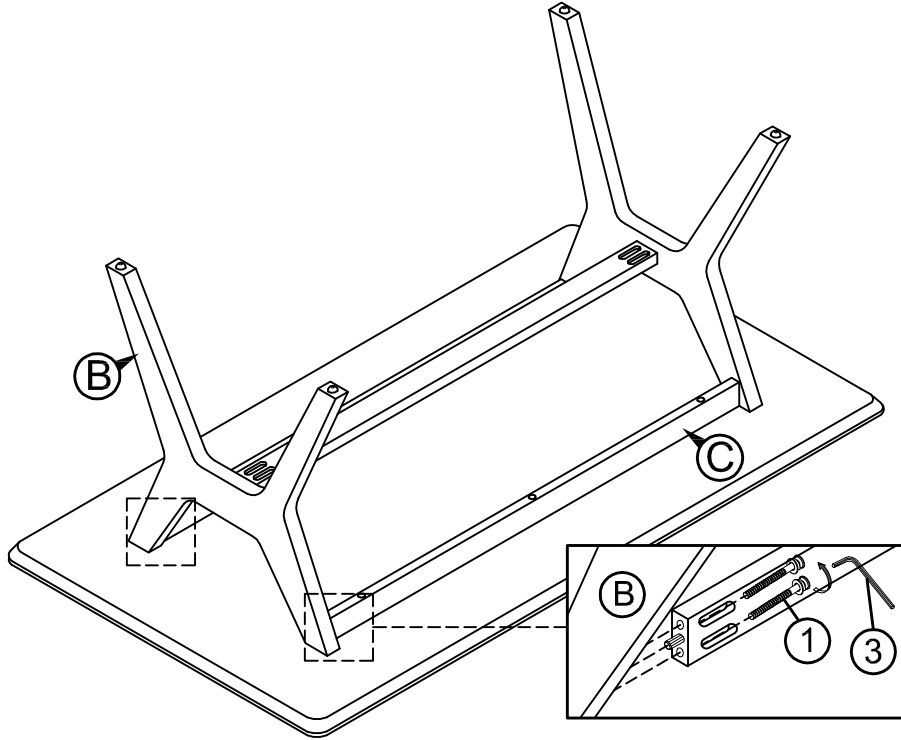

STEP 6 : The assembly is complete.

