







Assembly Instructions Item No.92539

Thank you for purchasing this quality product. Be sure to check The packing material carefully for small parts that may have come loose inside the during shipment.

Parts List				Hardware List			
No.	Description	Sketch	Qty	No.	Description	Sketch	Qty
A	Table Top		1	1	Screw Driver		1
B	Ring		1	2	Cap		8 + 2
C	Rod		4	3	Extra Floor Leveler		2
D	BaseRod		4				

Step-1 Unwrap the box and place table top (point A) reverse on the floor . After the, table the rod into the hole located in the table top.

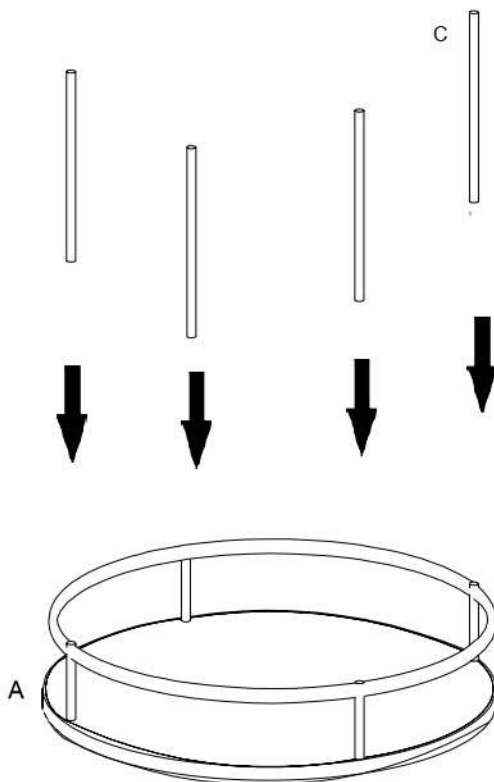

Step-2 After that place the ring on the rod As shown in the picture.

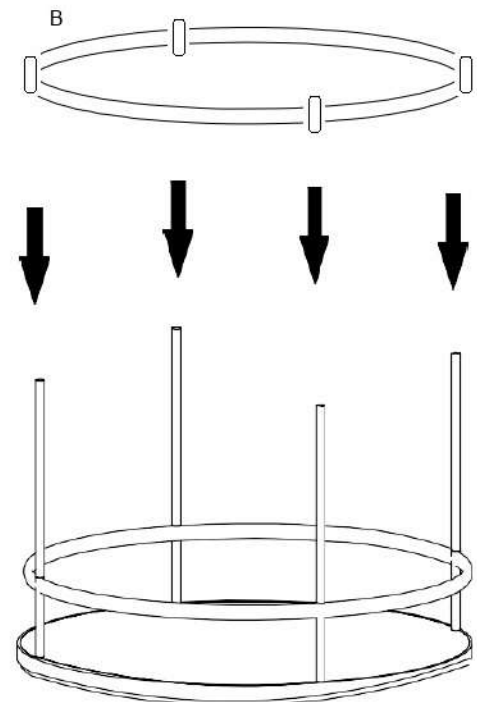

Assembly Instructions
Item No.92539

Step-3 Put the base rod in the hole of the ring and move in to clockwise

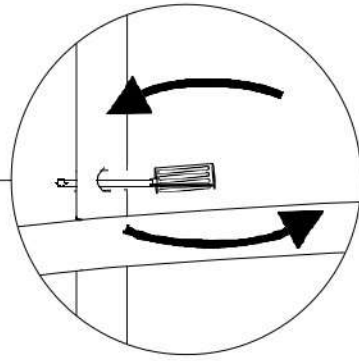
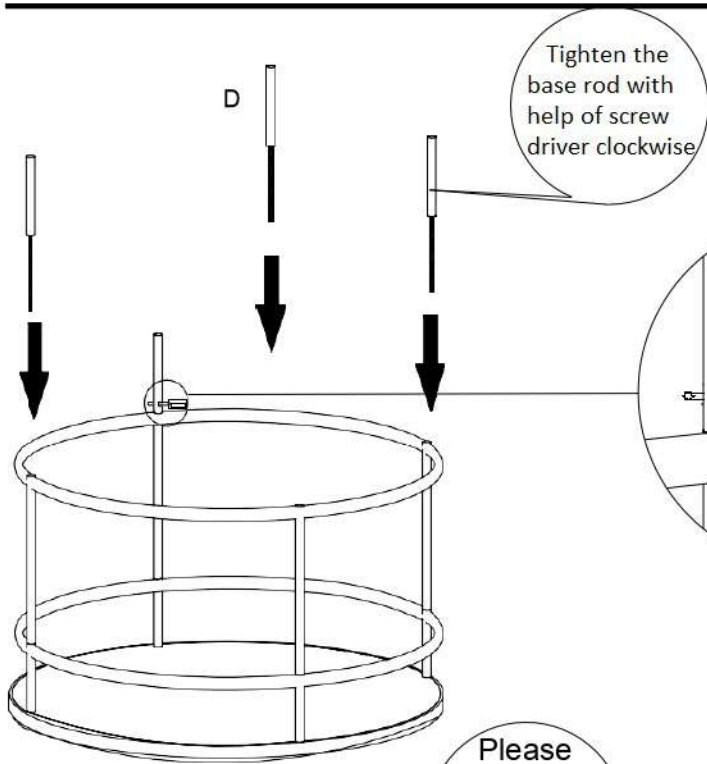

Please put the cap into hole. after fixing the legs .

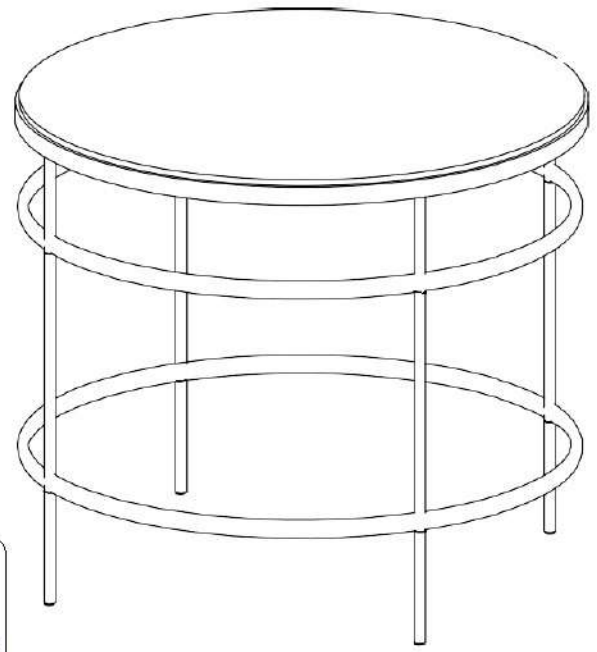
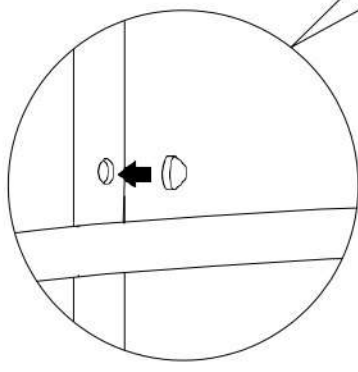

Final Product

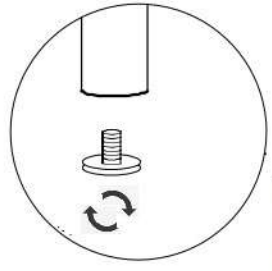

Tip for leveling of product. When the product rests an uneven floor surface it adjusting to be unbalanced. to aid in leveling, try adjusting the levelers located on the bottom of each foot.