

ASSEMBLY INSTRUCTIONS











Read this instruction carefully. See hardware and furniture part list for guidance. Be sure all parts are complete, before you assemble. Place all wooden furniture parts on a clean and flat soft surface to prevent from being scratched. Follow the figure to start assembling.

CAUTIONS : 1. Do not FULLY - TIGHTEN the nut or nut bolt until all nut or bolt is ready assembled.
2. Do not OVER - TIGHTEN the nut or bolt to avoid causing damages to the thread.
3. Keep all hardware parts out of reach of children.

NOTE : THE LIST AND QUANTITY SHOWN ARE FOR 1 UNIT ASSEMBLY.

Tool needed : Screwdriver (not provided).

PART LIST		
ITEM	DESCRIPTION	QTY
A	CHAIR	1PC
B	FRONT LEG	2 PCS
C	FRONT LEG SUPPORT (METAL)	1 PC
D	BACK LEG	2 PCS
E	BACK LEG SUPPORT	1 PC
F	SIDE RAIL	2 PCS

HARDWARE LIST		
ITEM	DESCRIPTION	QTY
1	JCBB BOLT M8 x 60mm 	8 PCS
2	WOOD SCREW M4 x 20mm 	2 PCS
3	WOOD SCREW M4 x 45mm 	6 PCS
4	WOOD SCREW M3.5 x 12mm 	12 PCS
5	WOOD SCREW M3.5 x 16mm 	12 PCS
6	M8 FLAT WASHER 	8 PCS
7	M8 SPRING WASHER 	8 PCS
8	M5 ALLEN KEY (BALL SHAPE) 	1 PC
9	5005 2 HOLE L BRACKET (BLACK) 	4 PCS
10	5003 2 HOLE L BRACKET (BLACK) 	8 PCS

STEP 1

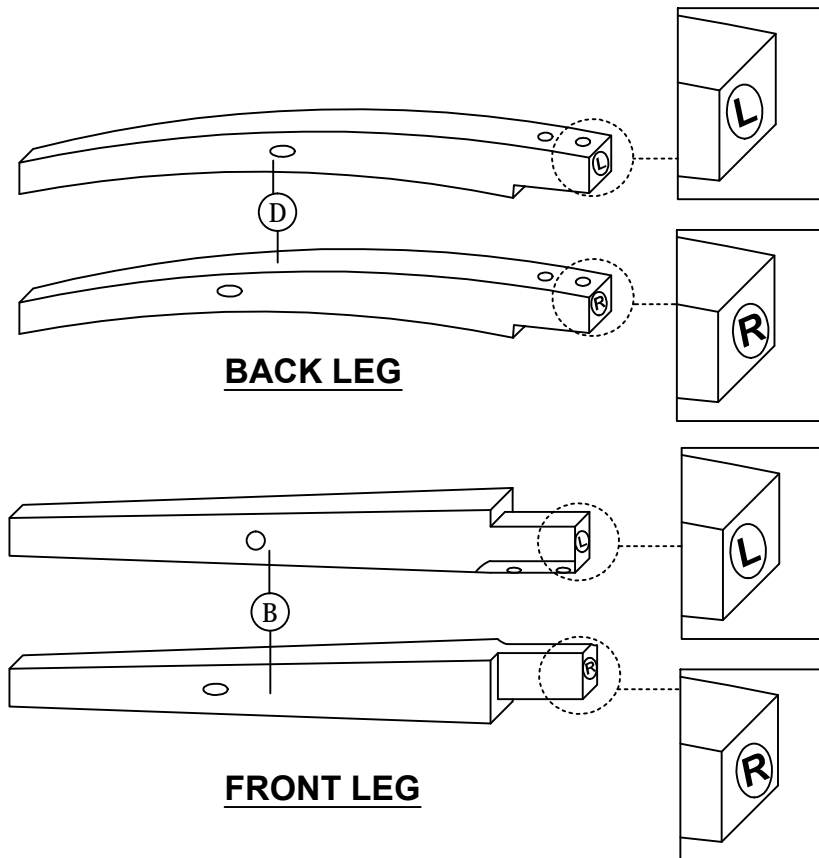

STEP 2

STEP 2.2

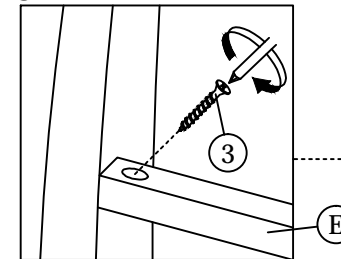

STEP 2.1

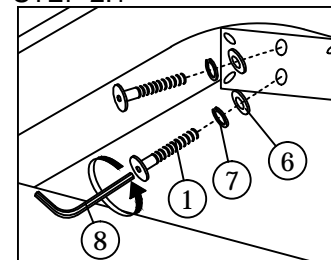

Don't screw tied

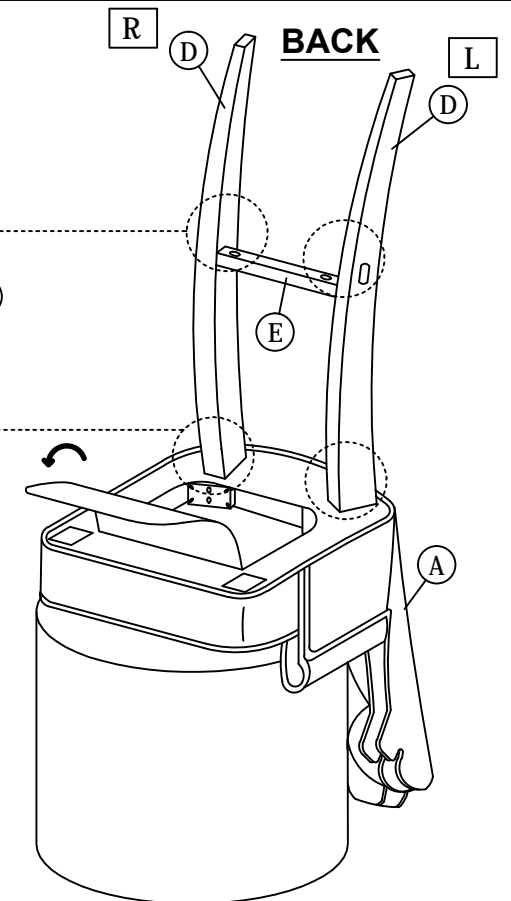

ASSEMBLY INSTRUCTIONS

STEP 3

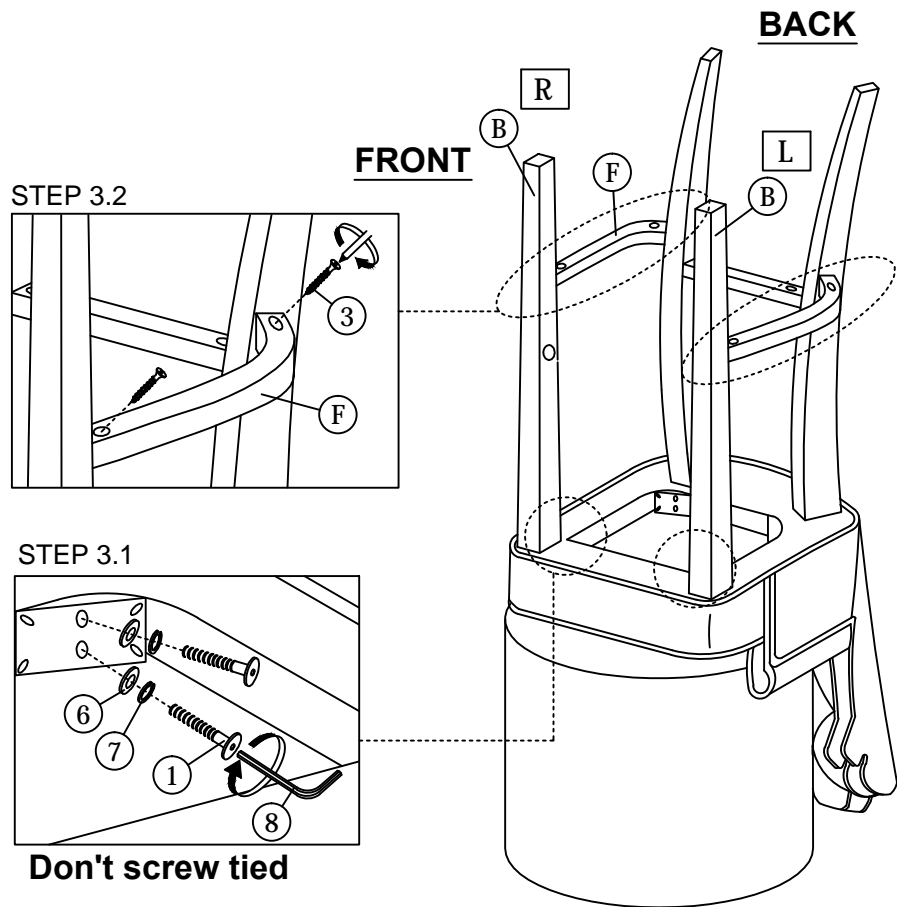

STEP 4

****Finish step 4,
Please screw tied the
step 2 & 3 bolt.**

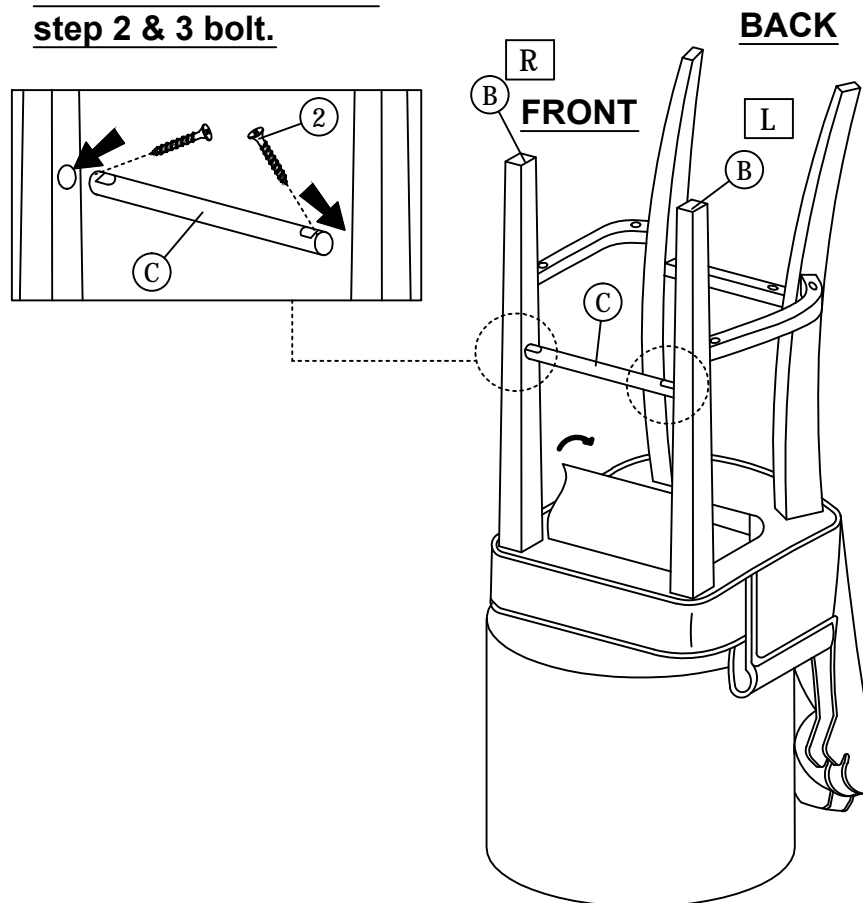

ASSEMBLY INSTRUCTIONS

STEP 5

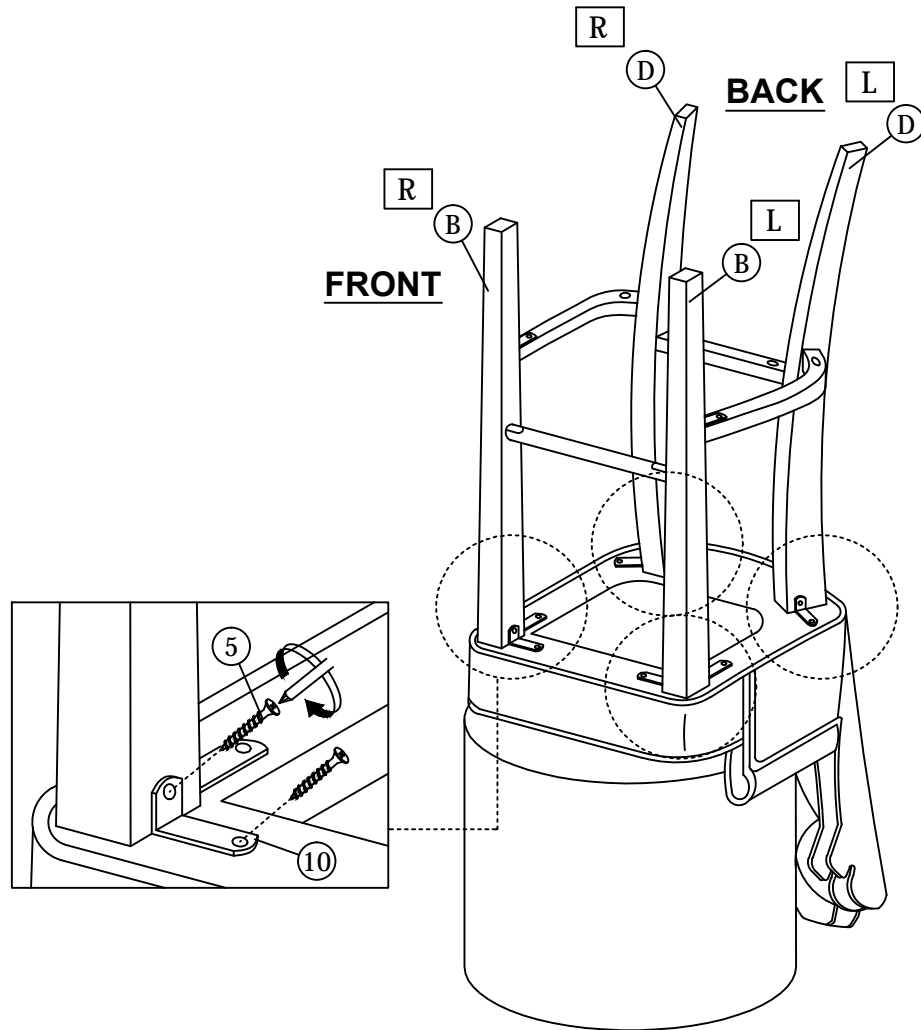

STEP 6

STEP 6.1

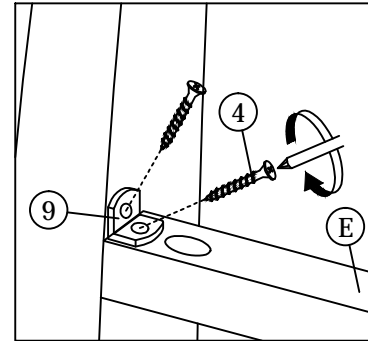

STEP 6.2

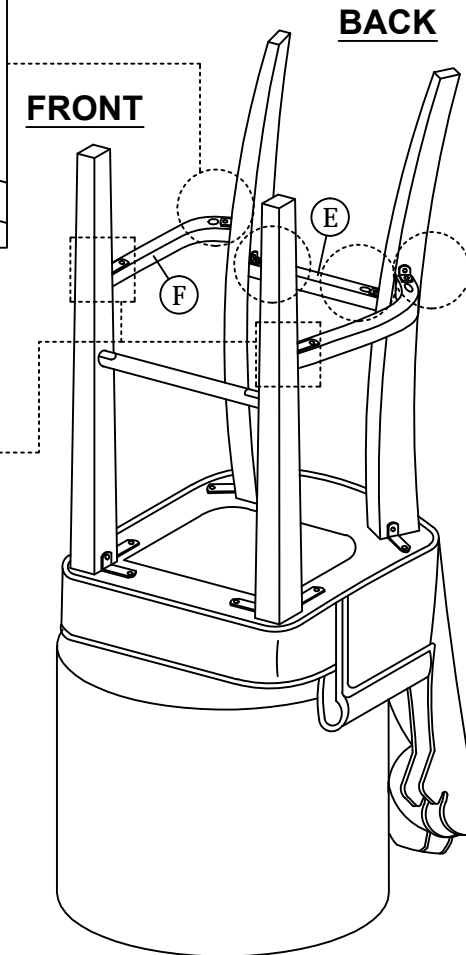
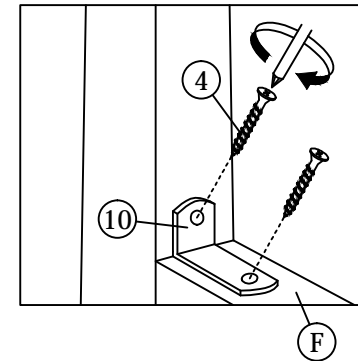

ASSEMBLY INSTRUCTIONS

STEP 7

