

# Full / Queen Headboard

## Assembly Instructions

### 1 Parts List

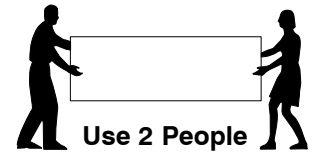
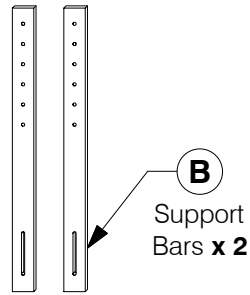
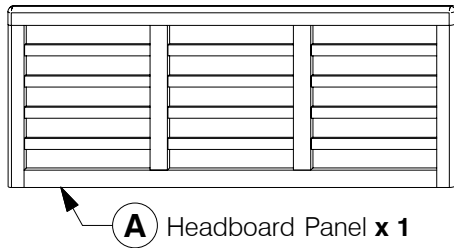

### 2 Hardware List

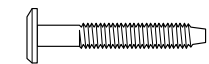

**1** M6 x 35mm JCB  
x 4



**2** Spring Washer  
x 4



**3** Flat Washer  
x 4



**4** Allen Key  
x 1

**Note:** Do not assemble using power tools. This can cause the bolts to be overtightened

### 3 Assemble the Support Bars (B) to the Headboard Panel.

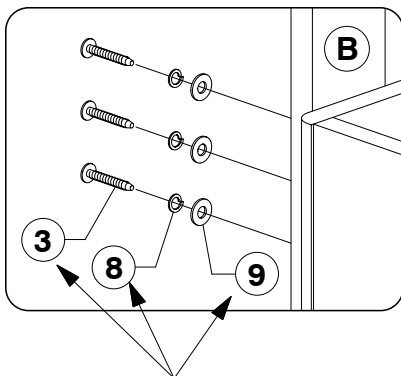

Note: Bolts & Washers from Footboard, Rails & Slats Box.

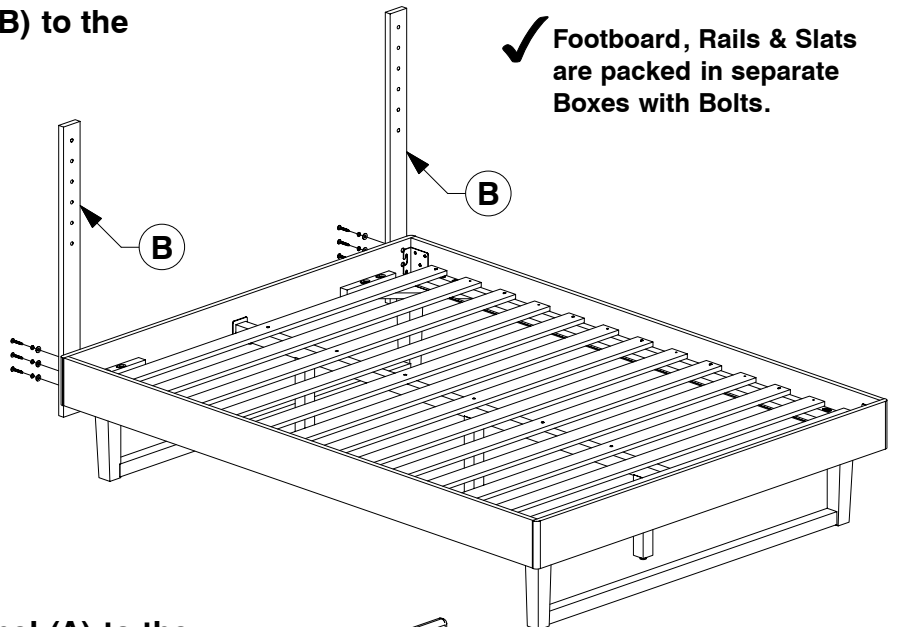

### 4 Assemble the Headboard Panel (A) to the Support Bars (B).

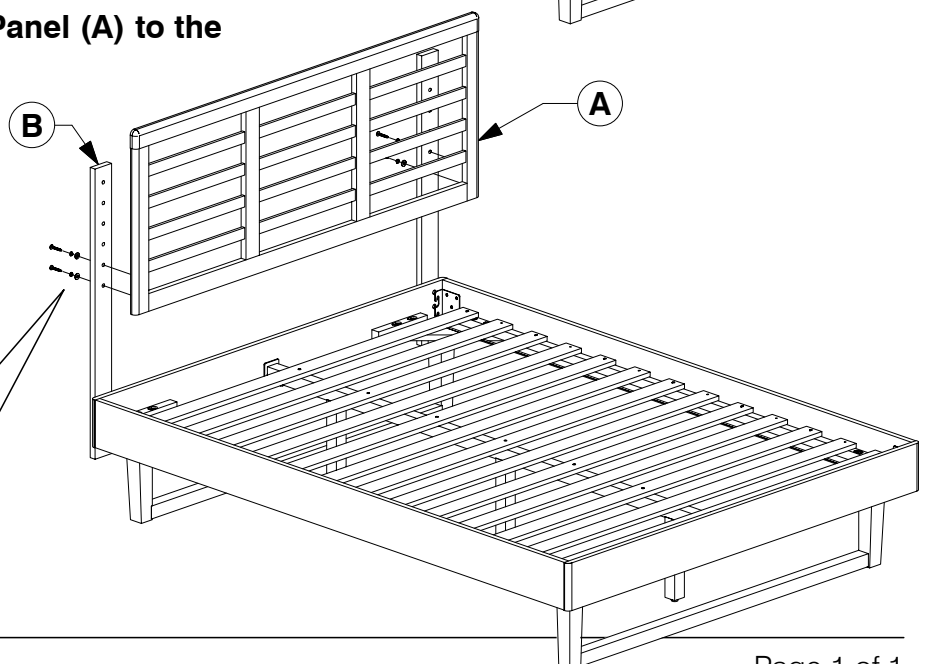
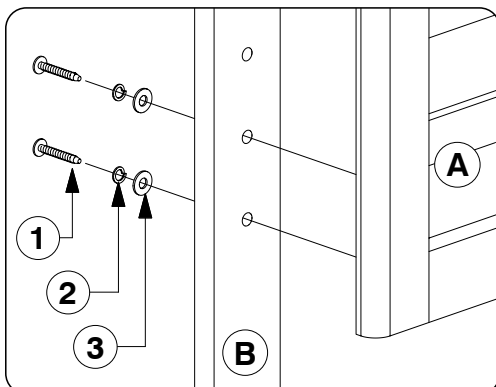

# Queen Bed

## Assembly Instructions

### 1 Assembled View

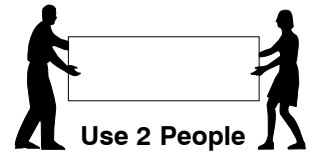
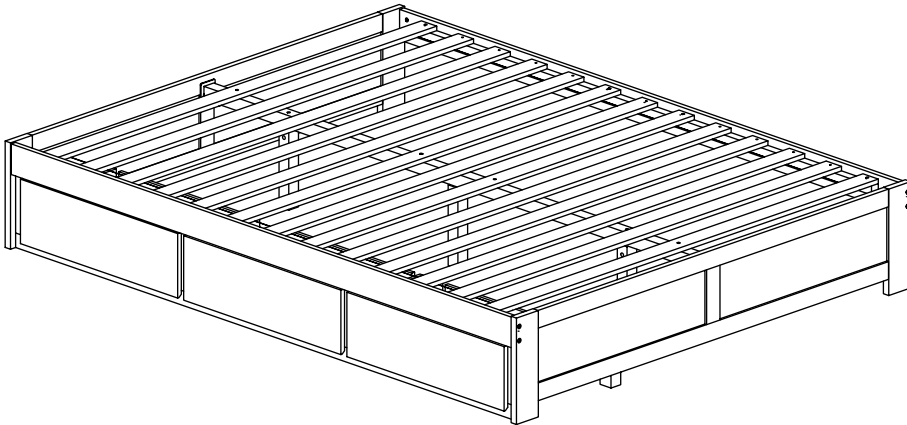

**Note:** Do not assemble using power tools. This can cause the bolts to be overtightened

### 2 Parts List

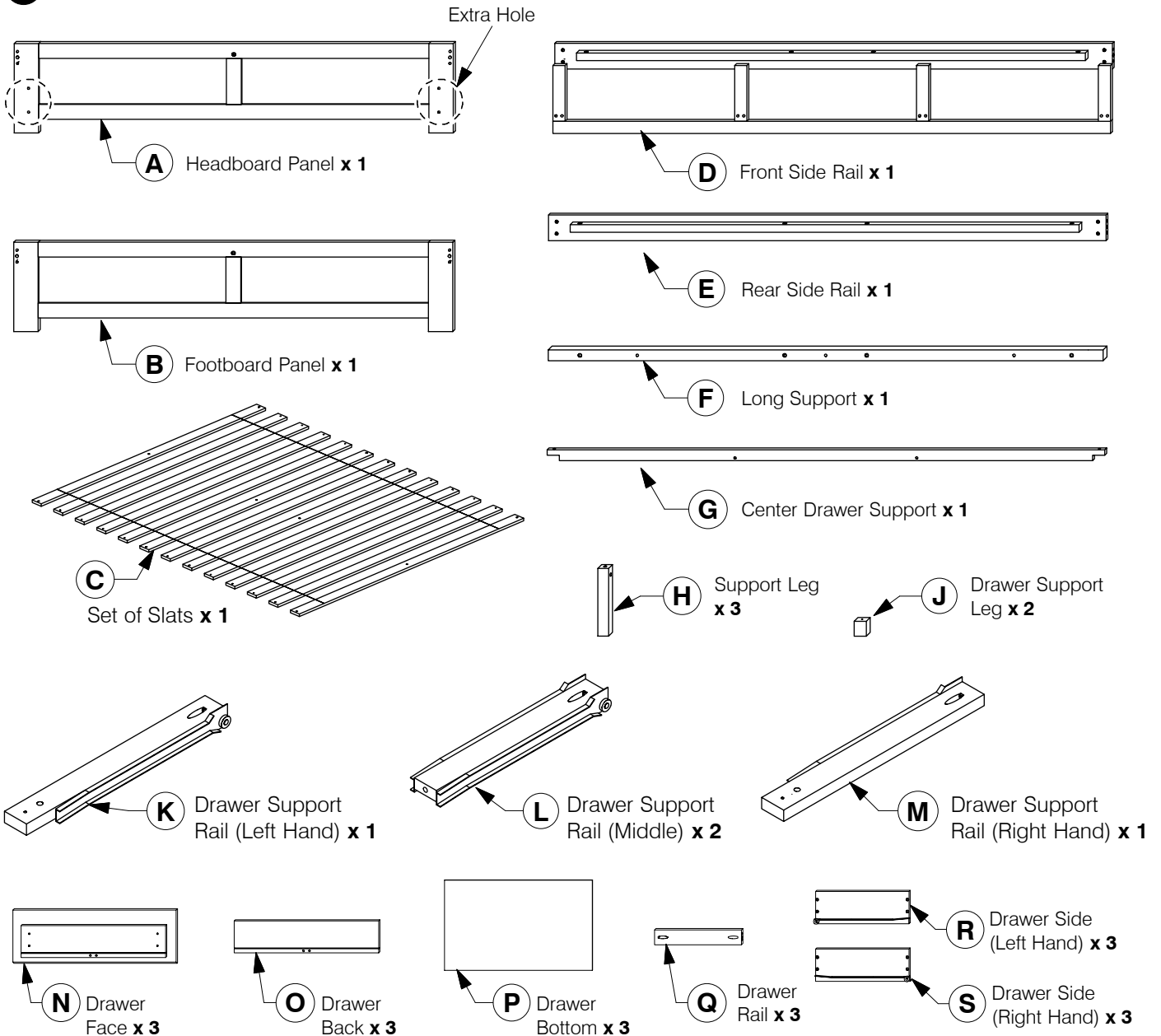

# Queen Bed

## Assembly Instructions

### 3 Hardware List



1 M6 x 90mm JCB  
x 3



2 M6 x 70mm JCB  
x 8



3 M6 x 40mm JCB  
x 20



4 M6 x 15mm JCB  
x 4

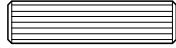

5 Wood Dowel  
(10 x 40mm) x 4

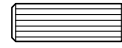

6 Wood Dowel  
(8 x 30mm) x 8



7 Wood Dowel  
(6 x 25mm) x 12



8 Barrel Nut  
x 11



9 Spring  
Washer x 4



10 Flat Washer  
x 4

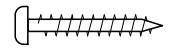

11 Wood Screw  
(M4 x 32mm) x 4

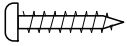

12 Wood Screw  
(M4 x 25mm) x 30

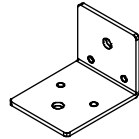

13 Center Rail  
Bracket x 2

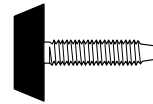

14 Adjustable  
Foot x 3

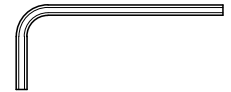

15 Allen Key  
x 1

### 4 Assembled the Support Legs (H) to the Long Support (F).

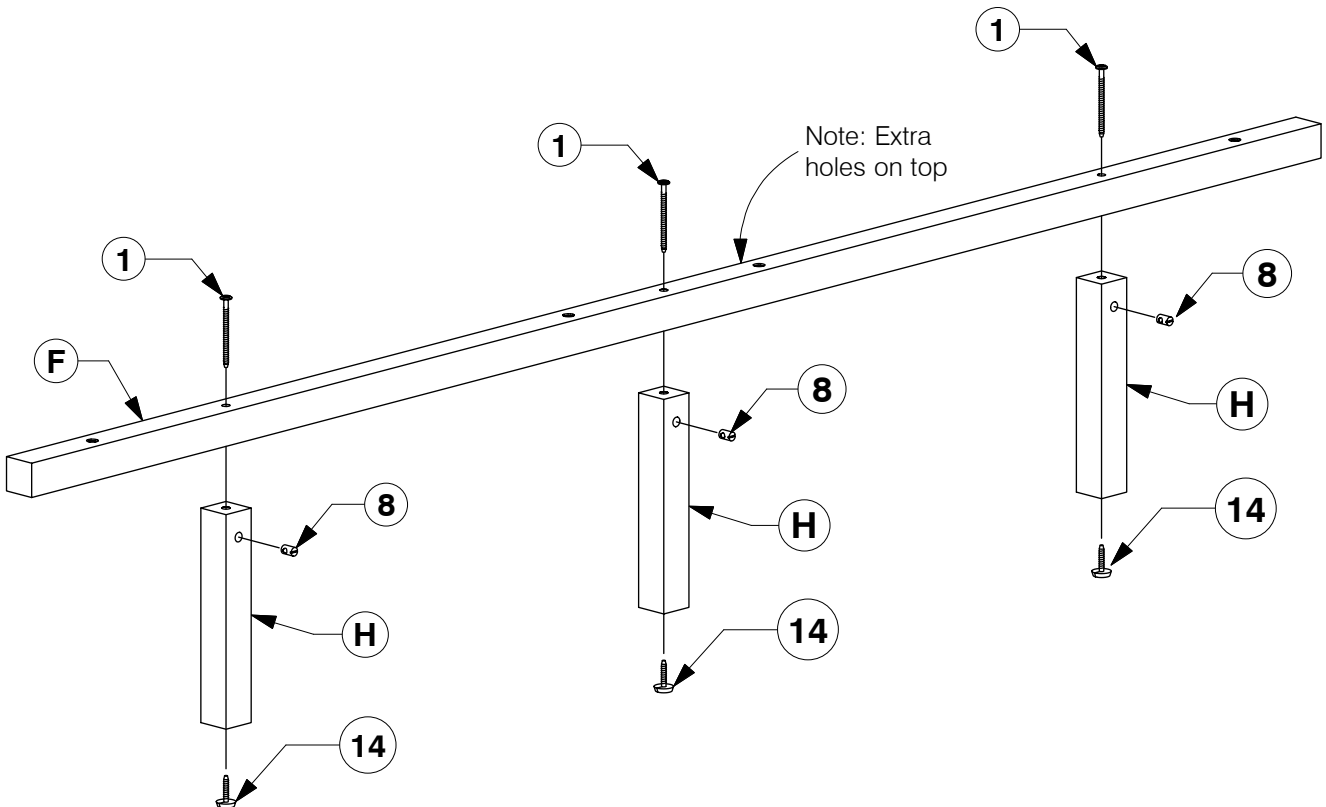

# Queen Bed

## Assembly Instructions

- 5** Assemble the Drawer Sides (R & S) and Drawer Rail (Q) to the Drawer Back (O). Make sure the small wheels on the Drawer Sides (R & S) are next to the Drawer Back (O).

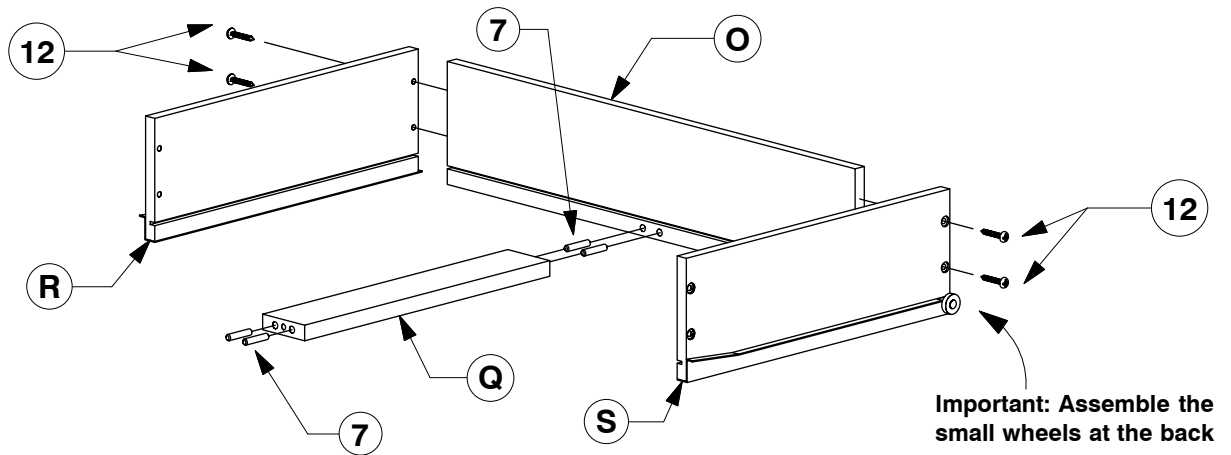

- 6** Slide the Drawer Bottom (P) into the groove on the Drawer Sides (R & S).

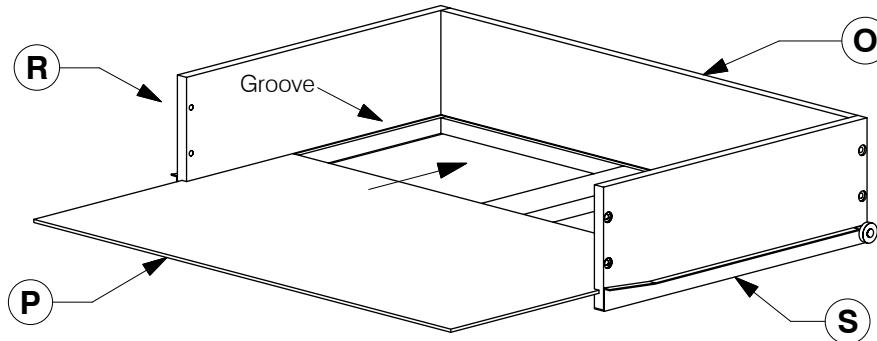

- 7** Assemble the Drawer Face (N) to the Drawer Sides (R & S).

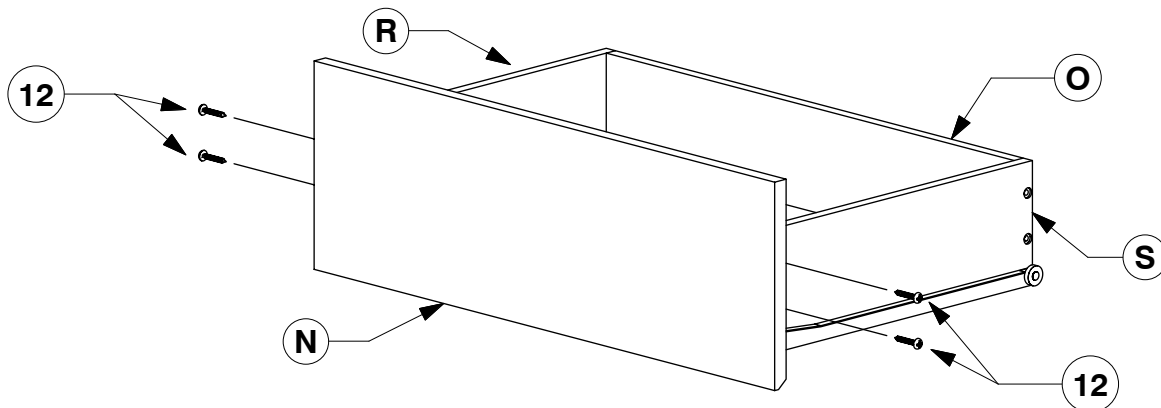

- 8** Turn the Drawer over to fit angled 25mm Wood screws (12) to the Drawer Rail (Q).

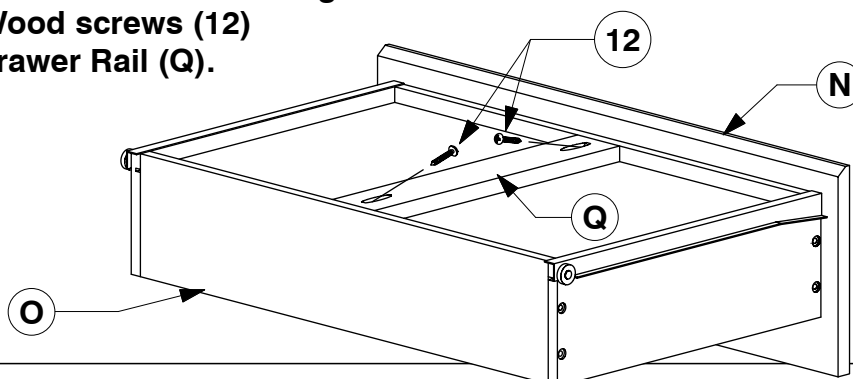

# Queen Bed

## Assembly Instructions

- 9** Fit the Center Rail Bracket (13) to the Headboard Panel (A).

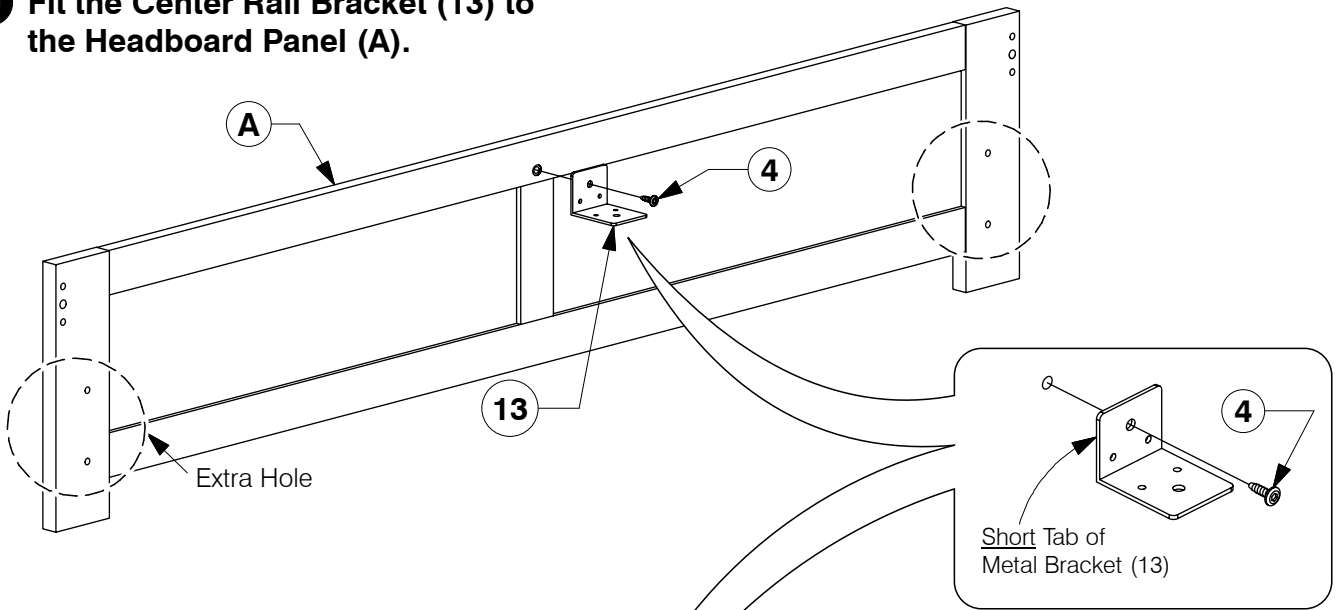

- 10** Fit the Center Rail Bracket (13) to the Footboard Panel (B).

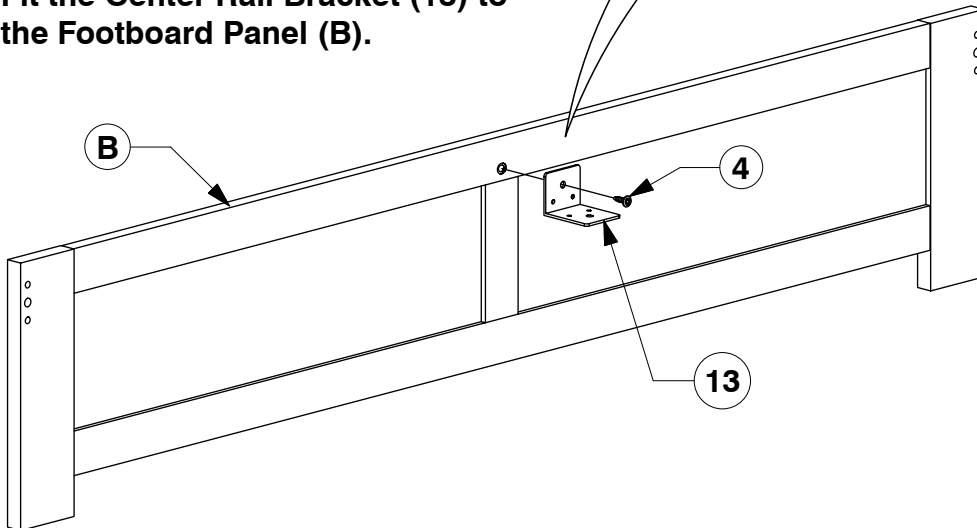

- 11** Assemble the Drawer Support Leg (J) to the Drawer Support Rail (K & M).

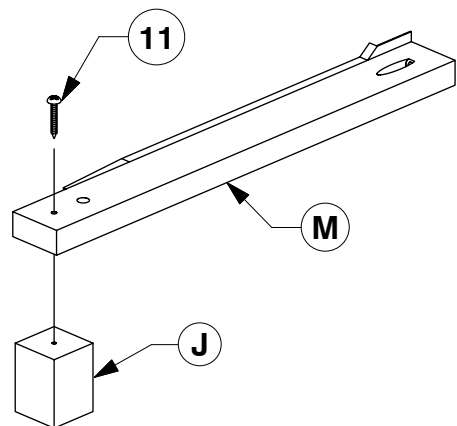
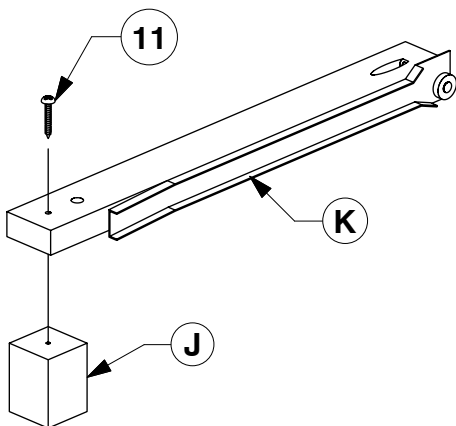

# Queen Bed

## Assembly Instructions

- 12** Attach the Drawer Supports Rail (K, L & M) to the Front Side Rail (D) using the Wood Dowels (6) and 32mm Wood Screw (11).

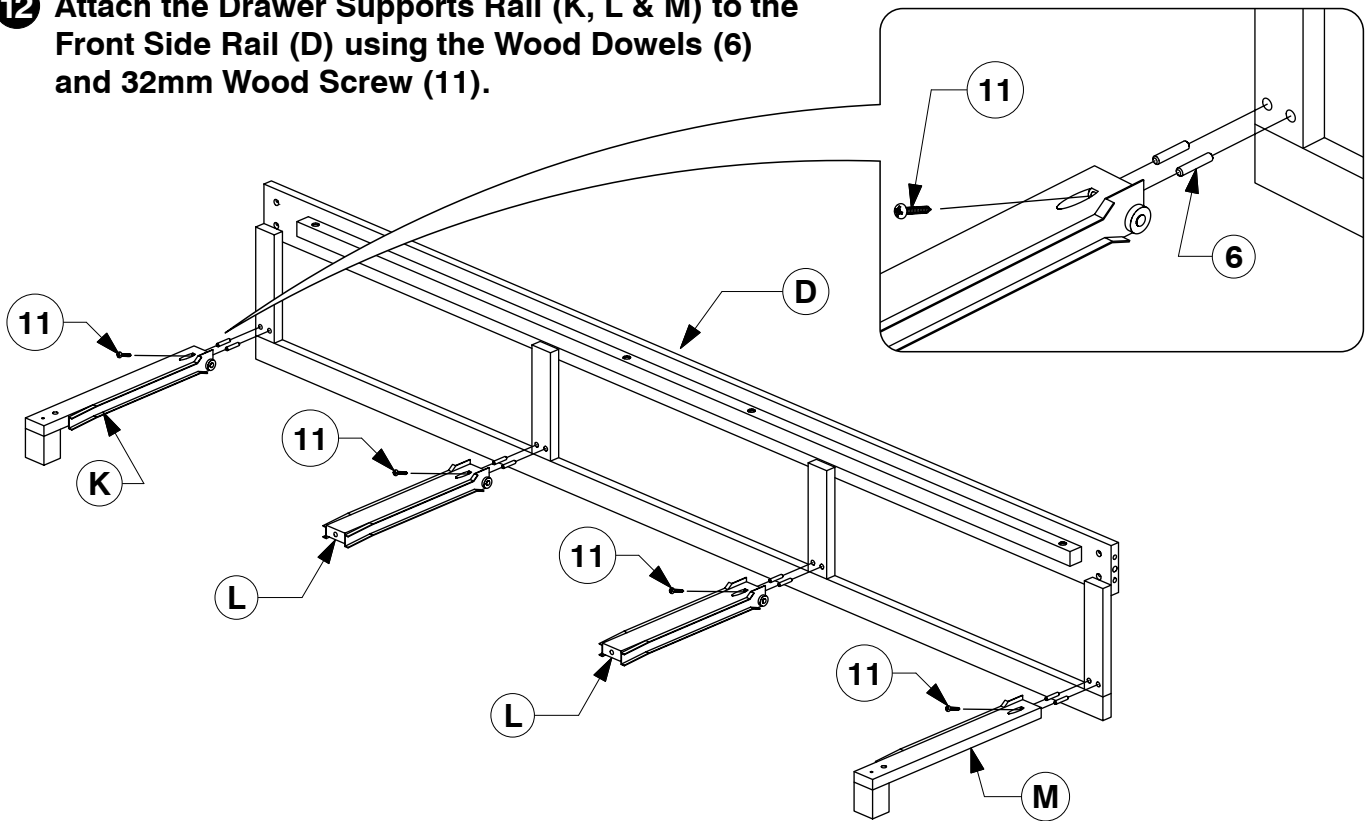

- 13** Bolt the Center Drawer Support (G) to the Drawer Support Rail (K, L & M).

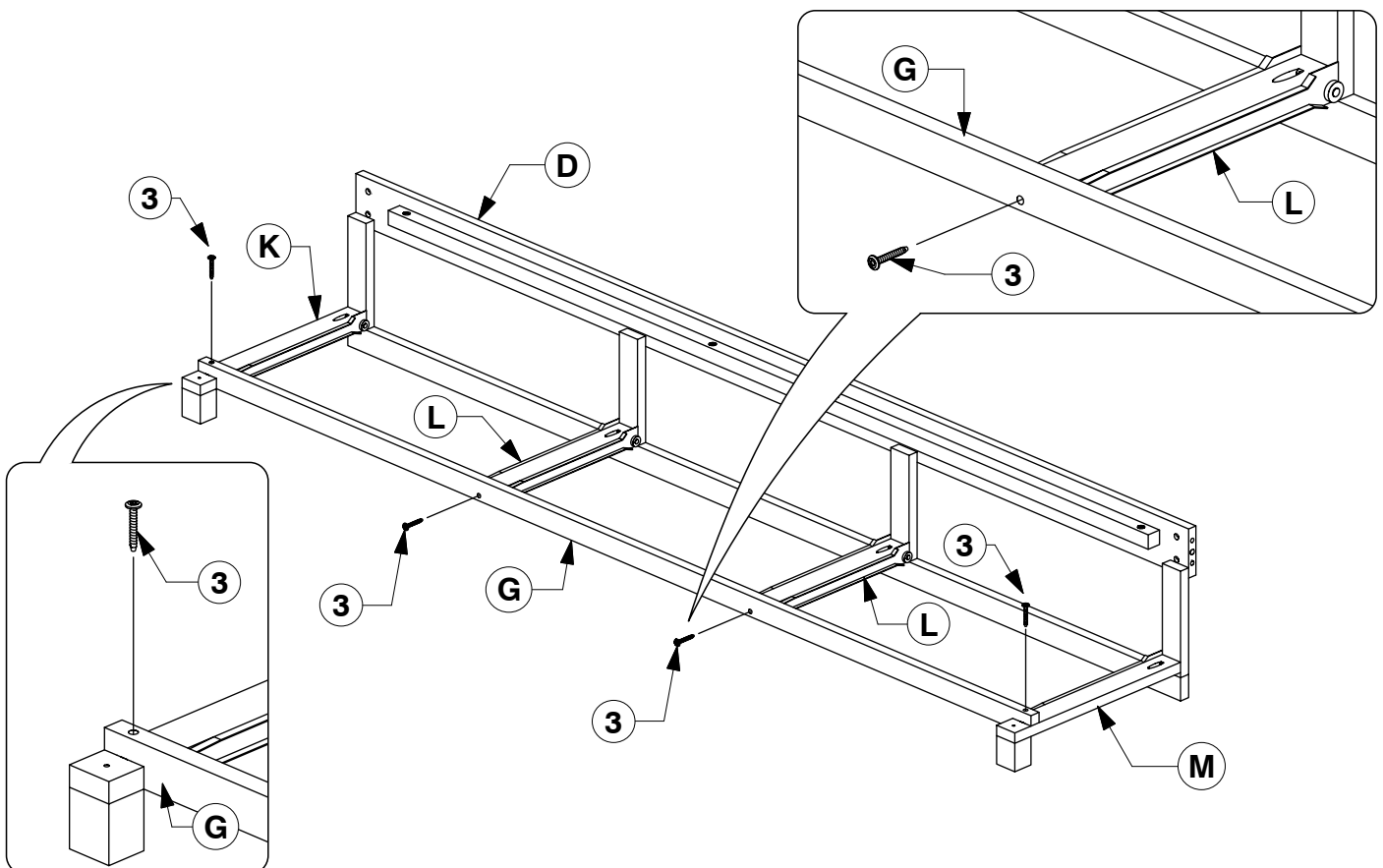

# Queen Bed

## Assembly Instructions

- 14** Assemble the Side Rail (D & E) to the assembled Headboard Panel (A) and Footboard Panel (B).

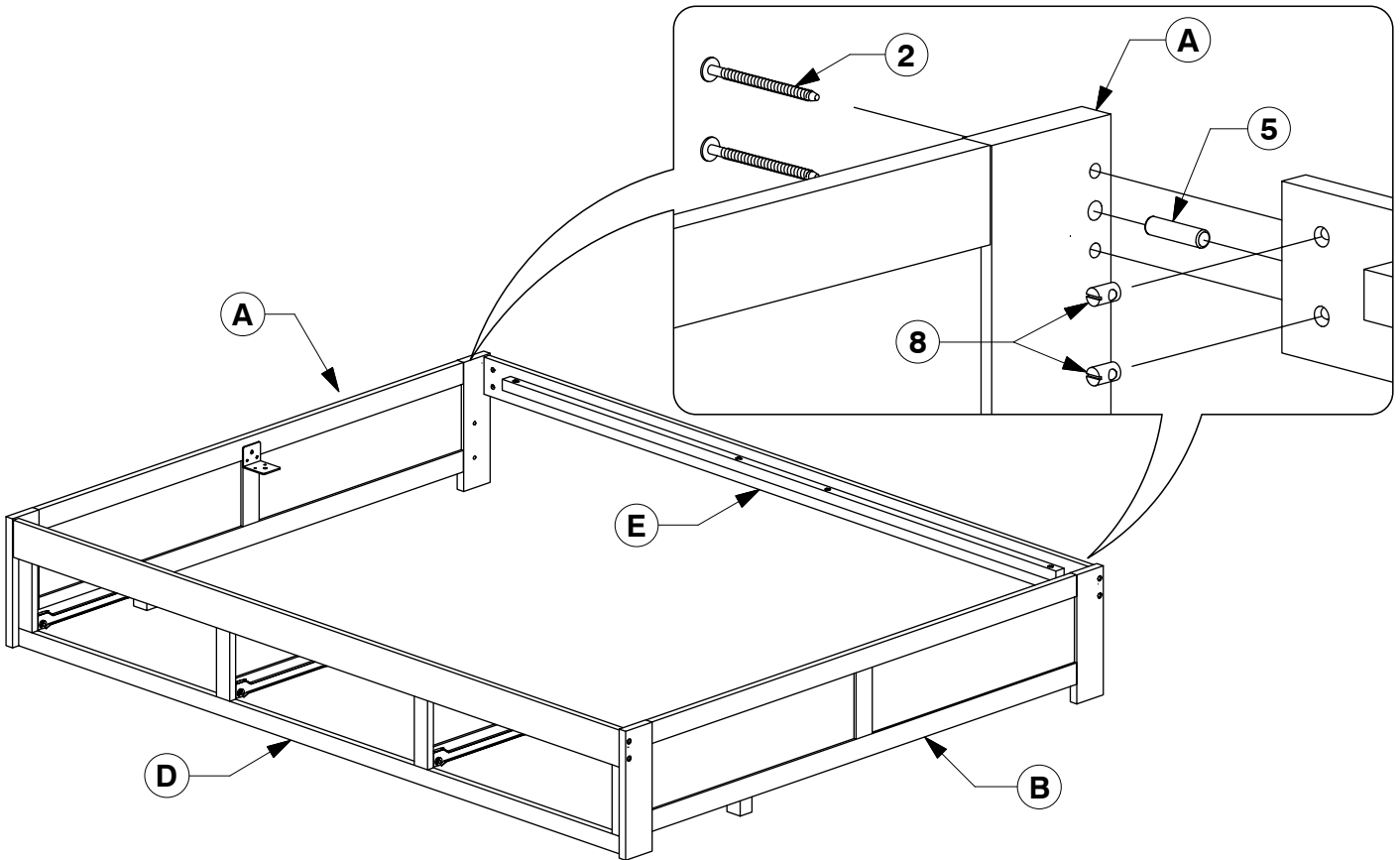

- 15** Bolt the Long Support (F) to the Center Rail Brackets (13) on the Headboard Panel (A) and Footboard Panel (B).

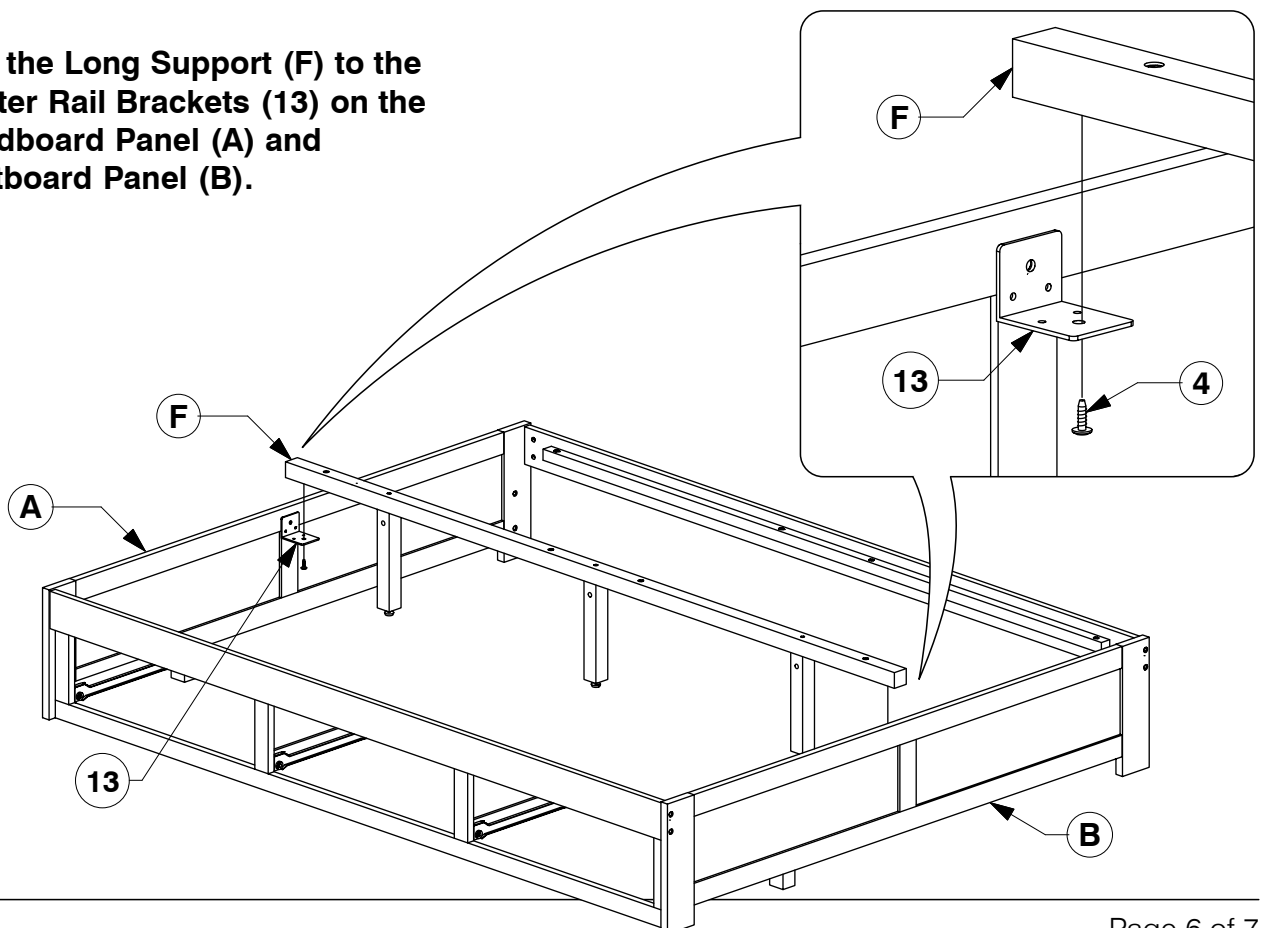

# Queen Bed

## Assembly Instructions

**16 Bolt the Slats (C) to the Side Rail (D & E).**

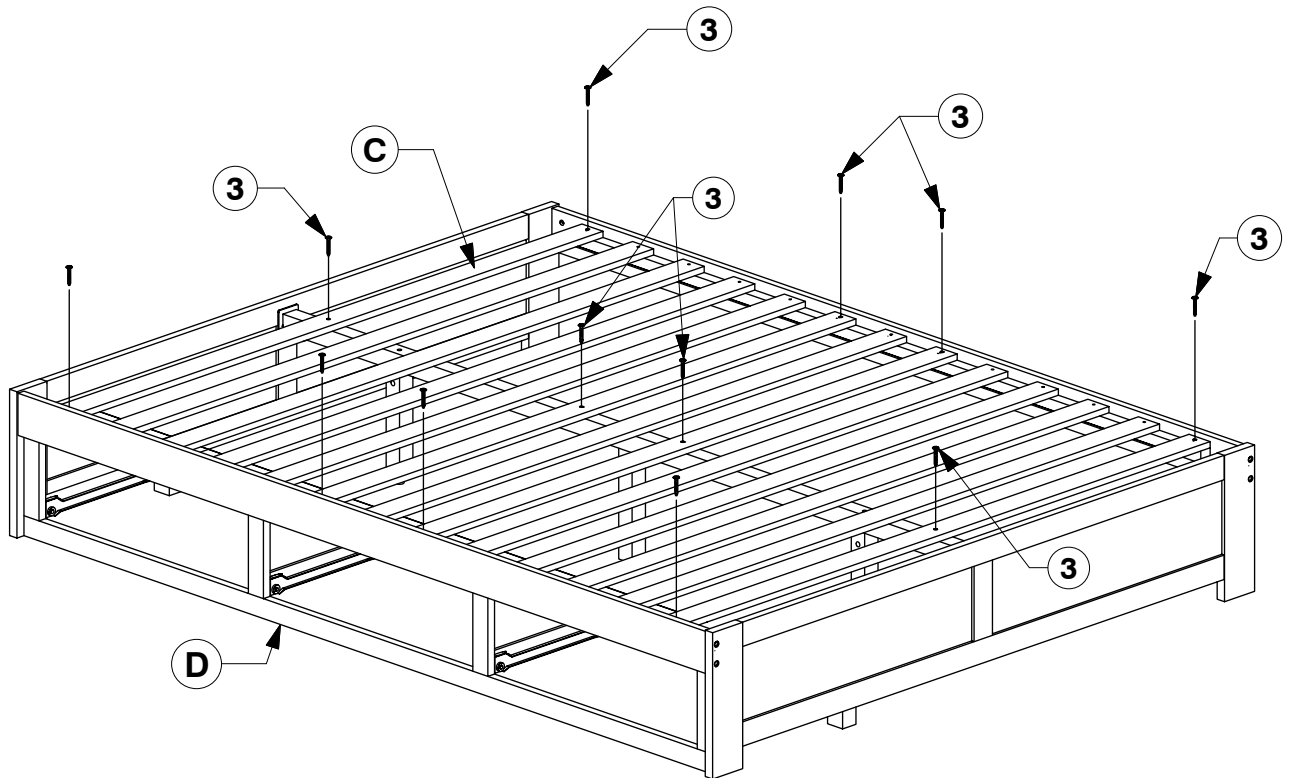

**17 Screw the Slats (C) to the Side Rail (D & E).**

**Finally fit the assembled Drawers.**

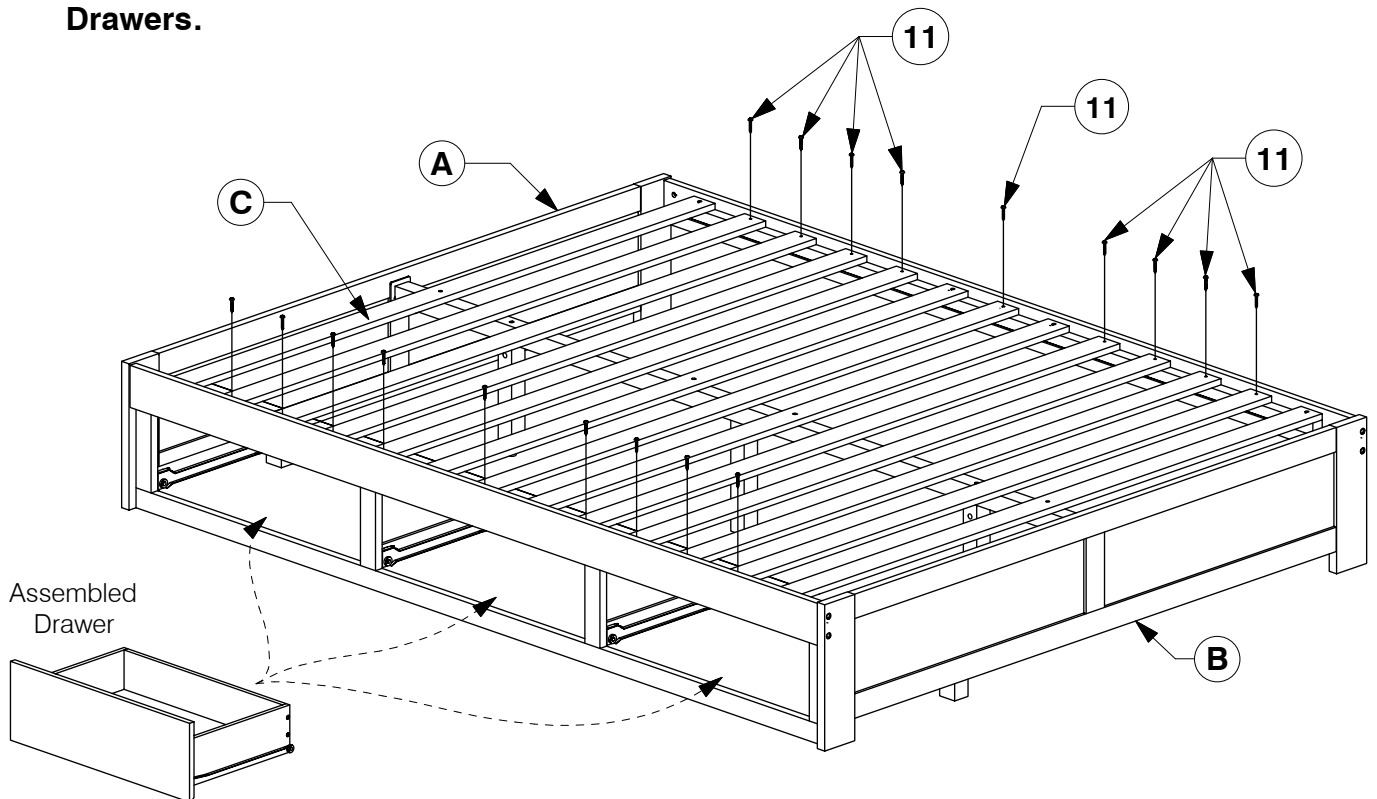

# King Headboard

## Assembly Instructions

### 1 Parts List

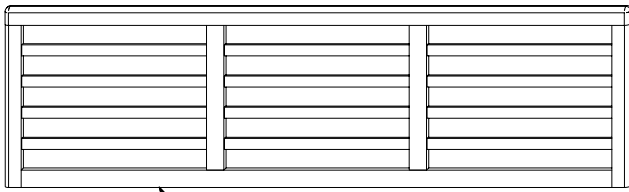

**A** Headboard Panel x 1

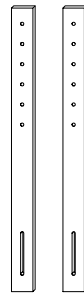

**B** Support Bars x 2

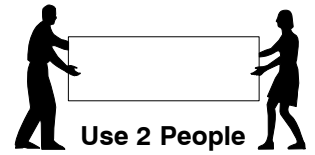

### 2 Hardware List



**1** M6 x 35mm JCB x 4



**2** Spring Washer x 4



**3** Flat Washer x 4



**4** Allen Key x 1

**Note:** Do not assemble using power tools. This can cause the bolts to be overtightened

### 3 Assemble the Support Bars (B) to the Headboard Panel.

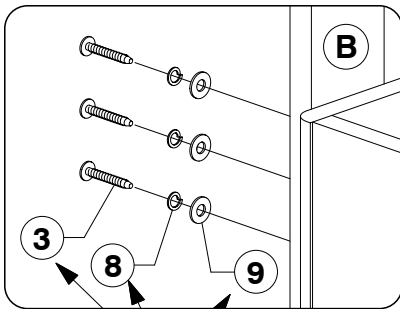

Note: Bolts & Washers from Footboard, Rails & Slats Box.

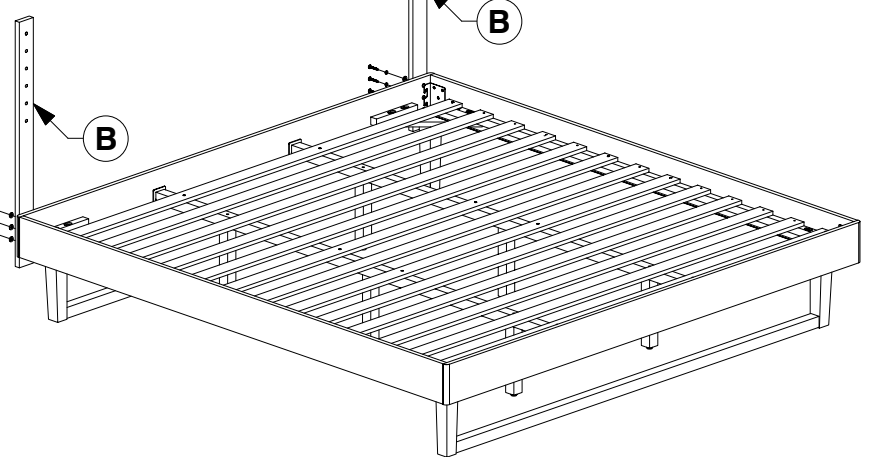

### 4 Assemble the Headboard Panel (A) to the Support Bars (B).

