

ASSEMBLY INSTRUCTION

BENCH

A Bench Top



1pc

B Leg

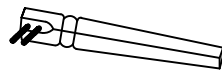

4pcs

C Nut
5/16" x 1/2"

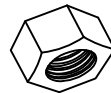

8pcs

D Lock Washer
5/16"



8pcs

E Flat Washer
5/16"

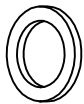

8pcs

F Wrench
1/2" x 2-3/8"



1pc

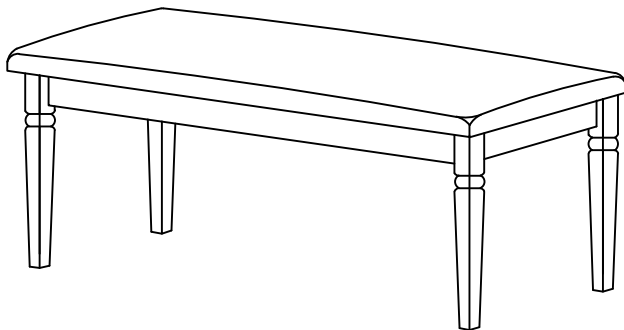

This page lists all the contents included in the box. Please take the time to identify the hardware as well as the individual components to this product. As you unpack and prepare for assembly, place the contents on a carpeted or padded area to protect them from damage.

1

Put Bench Top (A) on smooth flat surface. Attach the four Leg (B) to the Bench Top (A) use Nut (C), Lock Washer (D) and Flat Washer (E) on eight holes of the Bench Top (A). Turn the Wrench (F) in the Nut (C). Hand tighten only at this moment by using Wrench (F).

Take the Wrench, and turn the Nut until the legs are secure. **DO NOT TIGHTEN COMPLETELY.** Stop when you feel you are adding force to tighten the Nut.

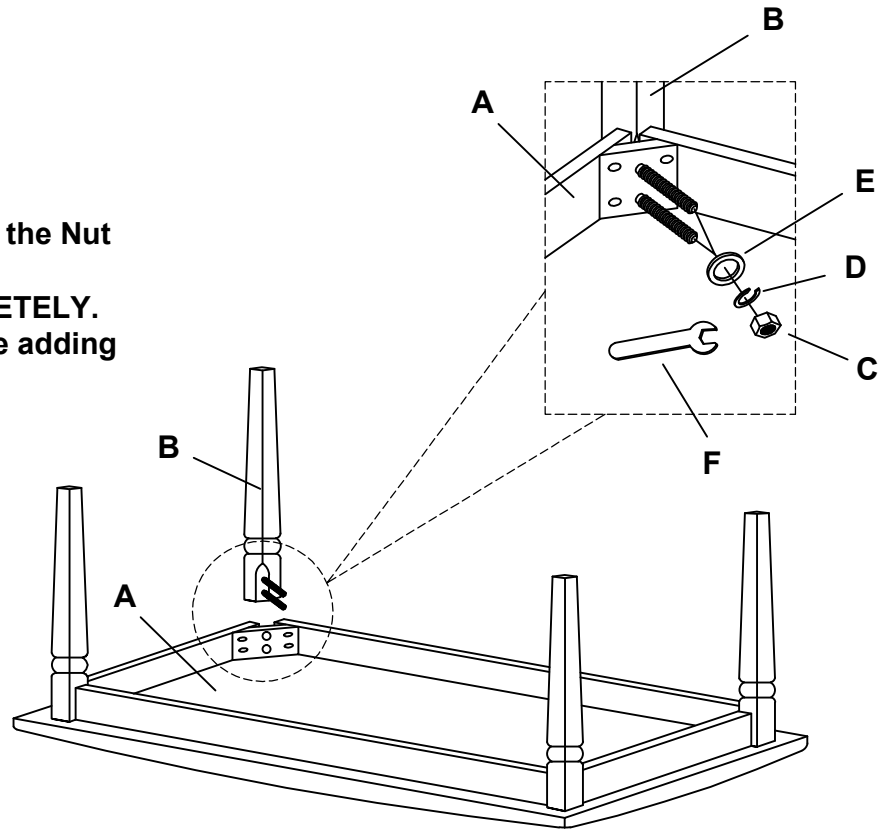

Stand bench up on an even surface and check that it is balanced. If there is a slight wobble, apply downward pressure in the corner where a leg is uneven. Keeping pressure in that corner, tighten all nut. If balanced, apply downward pressure evenly in the center and tighten all nut. Do not over-tighten beyond hole depth.

Cleaning & Care:

Treat surface with care. Surface is resistant to scratches but is not scratch resistant. Clean surfaces with a dry or damp soft cloth. Do not use abrasive cleaners. Hardware may loosen over time. Periodically check that all connections are tight.