

Assembly Manual

Dining Chair

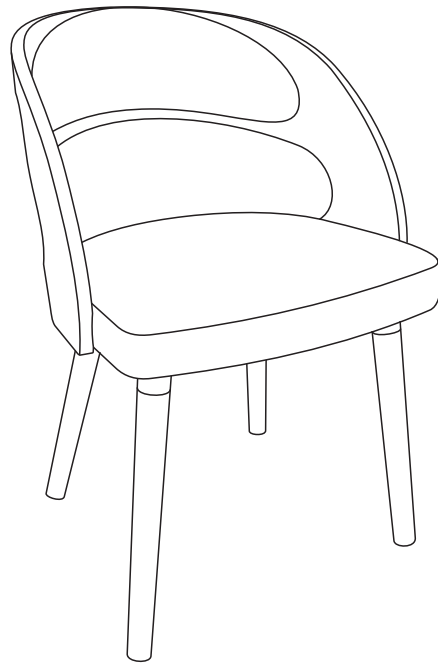

Assembly note:

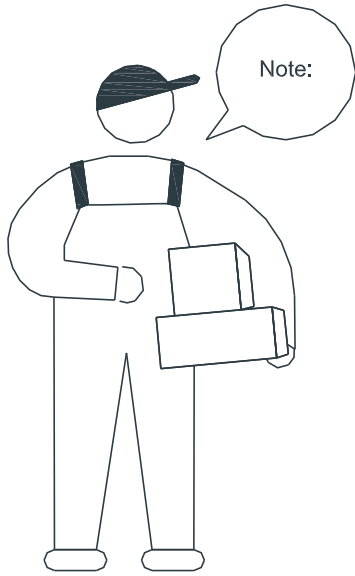

Put a protective mat on the ground and handle the product with care.

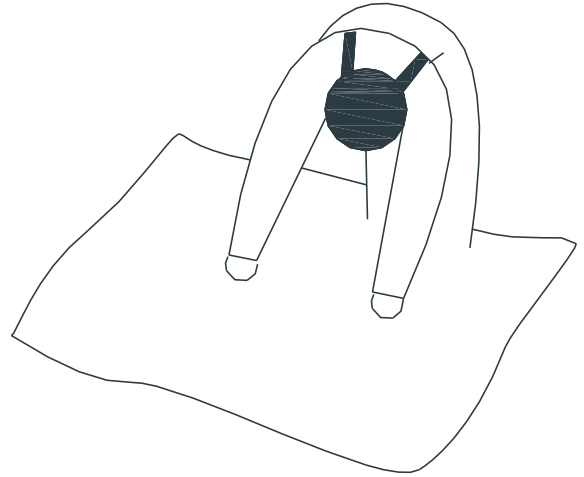

Two people are preferred.

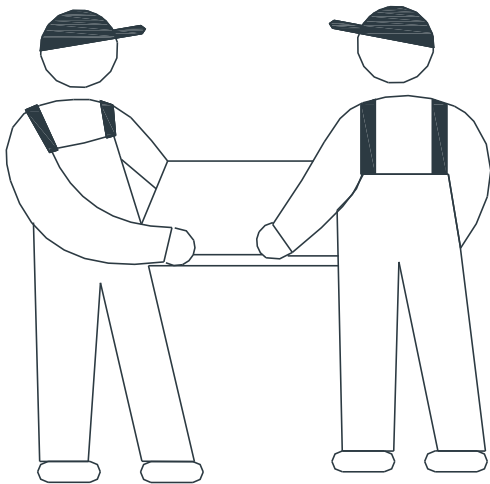

Contact us if you have any confusions.

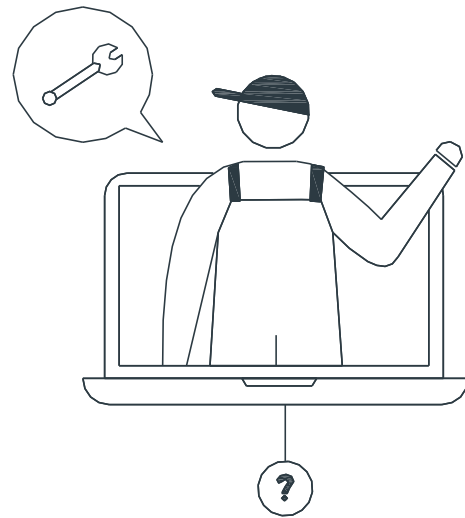

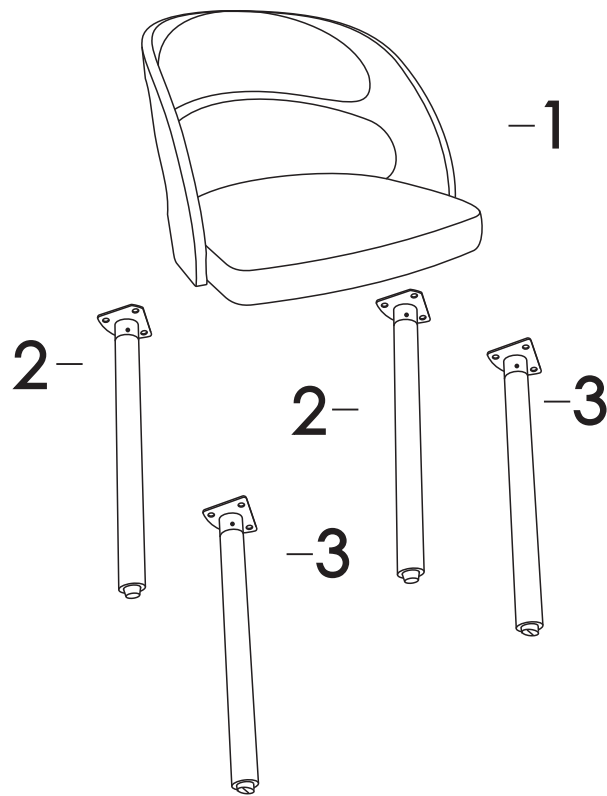

Exploded diagram:

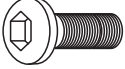

No.	Name	Pcs
1	Seat	1
2	Leg-1	2
3	Leg-2	2

Accessory list:

A			B		
					
Bolt	M6x16mm	12+1	Allen key	M6	1

Note: The number after "+" sign indicates the extra piece(s).

1. Attach Legs -1&2 (2&3) to the seat(1) using bolts(A)and Allen key(B).
 - Do NOT fully tighten the bolts until all of them are in the correct holes. This will allow you slight adjustments during the assembly.

1

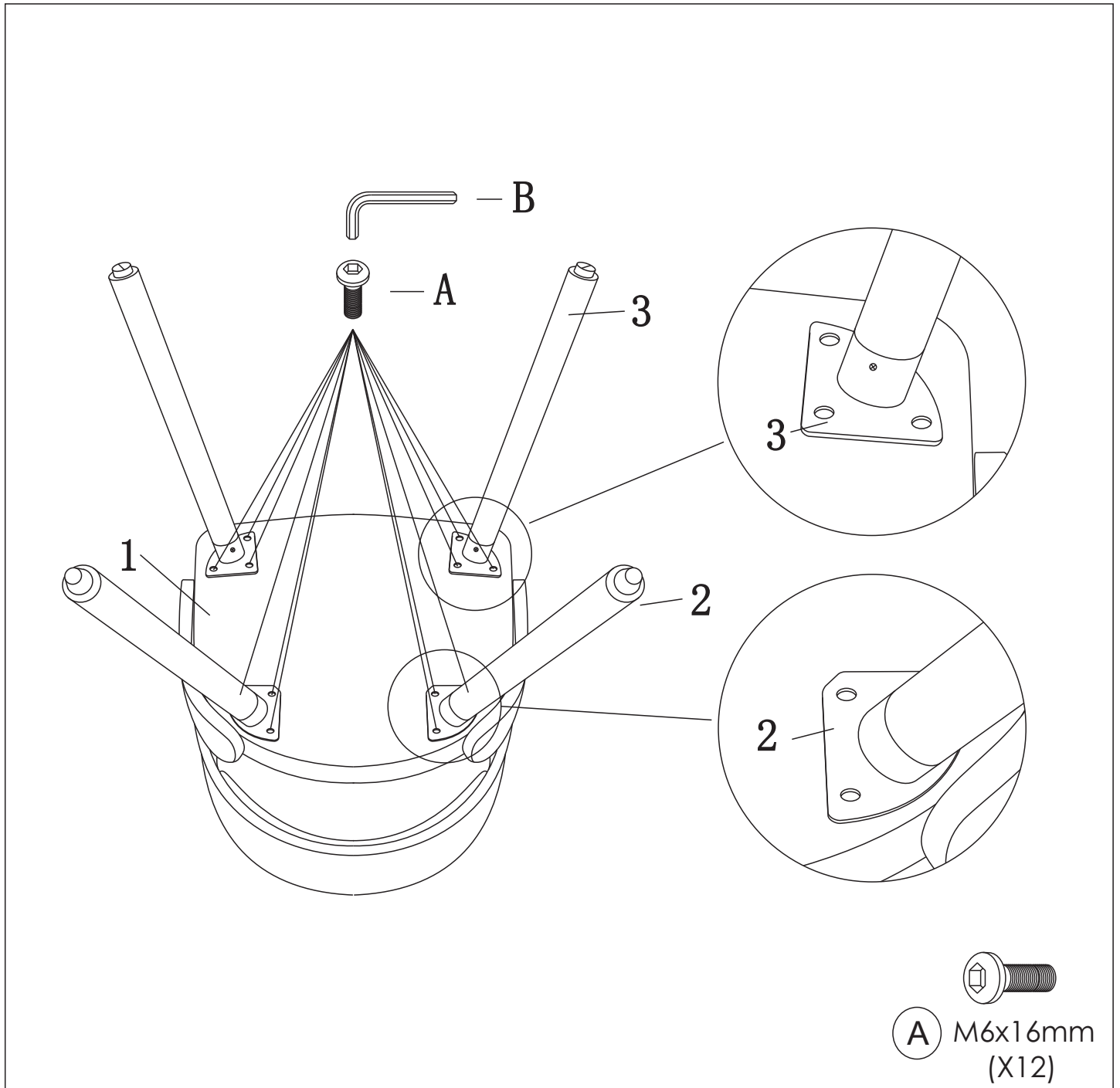

Done

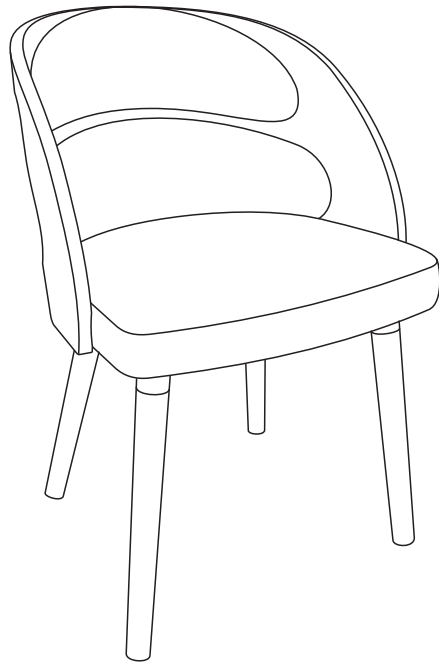

Warning

- Please keep the product away from children while assembling.
- Do not let children play or jump on the product.
- Do not stand on the item or use as a step ladder.
- Prior to use, please check to see if there's any loosening screw or part.
- Make sure that each screw and part is correctly installed and securely fastened.

Care and Maintenance

- Use a soft clean cloth that will not scratch the surface when dusting.
- There's no need to use furniture polish. If you need, test it first in an inconspicuous area.
- Using solvents of any kind on your furniture may damage the finish.
- Never use water to clean your furniture as it may cause damage to the finish.
- Liquid spills should be removed immediately.
- Gently blot the spill with a soft clean cloth to avoid rubbing.

Further advice about the furniture care

- It is best to keep your furniture in a climate-controlled environment.
- Extreme temperatures and humidity changes can cause fading, warping, shrinking and spitting of wood.
- We recommend to keep furniture from sunlight exposure to avoid possible surface damage.
- Proper maintenance and cleaning at home will extend the life of your purchase.
- Following these important and helpful tips will help retain your furniture's performance even when it ages.
- Periodically (every 90 days) make sure the screws are fully tightened.

Weight capacity: 300LBS.

Warmly after-sales service

Please check all the hardware and the furniture before assembling. Once there is anything missing, please feel free to contact us . If you only leave a message on the platform, we cannot help you to solve the problem effectively. Timely communication helps us understand your situation and gives you the best shopping experience.

Return Policy

Length of return period:

Items can be returned within 30 days of receipt of shipment.

Who is responsible for the return shipping fee?

We will cover the return shipping fees if:

1. Your item has a manufacturing defect in materials or workmanship.
2. Your item has been damaged in transit.
3. You received the wrong box(es) due to a warehouse error. We will send you a prepaid shipping label after photos are sent of the wrong boxes.
4. One or more boxes are lost in transit. We will send you a prepaid shipping label if you no longer want the item.

*However, we still hope to work with you for a better solution instead of a return. Please don't hesitate to reach out to us. Customer will cover the return shipping fees if:

1. You don't like the product(s) after receiving the box(es).
2. You no longer need the product(s) but you have received the box(es).
3. You buy the product(s) by mistake but you have received the box(es). What to do before FedEx picks it up:

Make sure everything is back in the original packaging and the prior opening will not affect the reselling of the product. First, you can try to get prepaid labels for UPS express return. Or we will provide prepaid shipping labels after you provide the photos of before & after packaging. Just stick the label on the box and call FedEx to pick it up.

When will I be refunded?

The refund is released once the goods have been returned to our warehouse. If you have any questions, please reach out to us and we will come up with a solution to make sure you are satisfied.