

NOTE:

This brochure contains **IMPORTANT** safety info. Please read and keep for future reference.

MAINTAINANCE AND WARNING

- 1.Keep furniture away from heat sources.
- 2.Do not clean furniture with harsh cleaner or polishes.Do not use detergents,solvents,abrasives,spray packs or leather cleaner. Use non-color mild soa with warm water to clean spills(Mix 1:10 soap to water).
- 3.Do not place furniture under direct sunlight,material will possibly fade over time.
- 4.Do not use on site dry cleaning machine.Children should not climb or jump on the furniture.
- 5.Do not write on furniture that is not protectedby a padded barrier.
- 6.Not for commercial use,only for residential use.

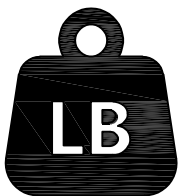

Weight Limitation
100 LBS

EXPLOSIVE VIEW

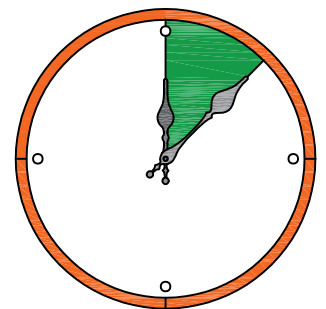
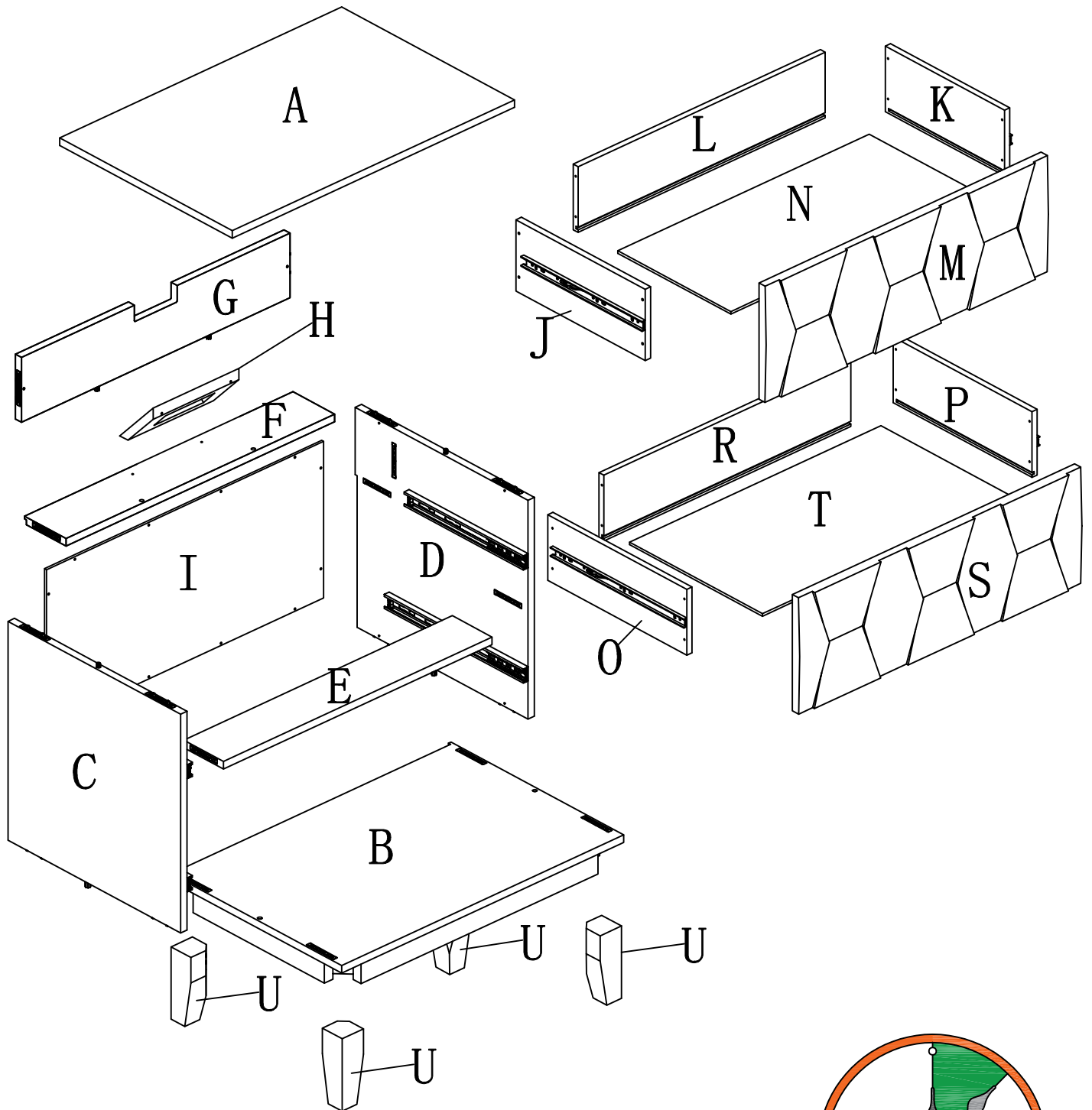

Around 45 min

PARTS LIST

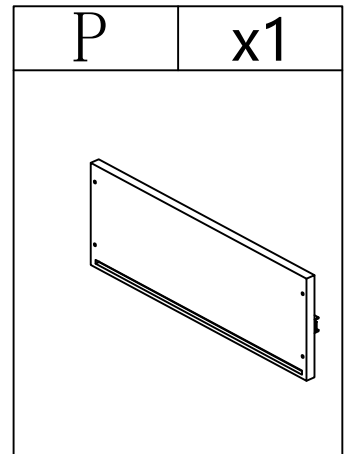
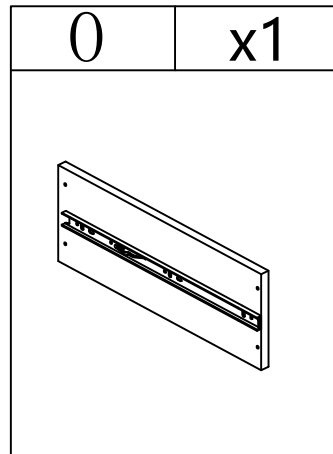
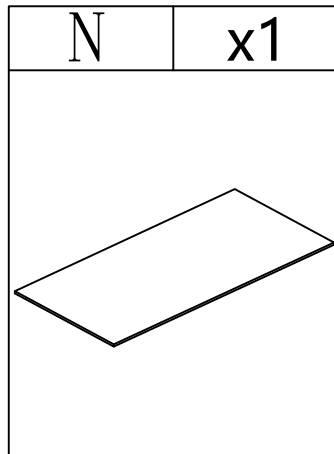
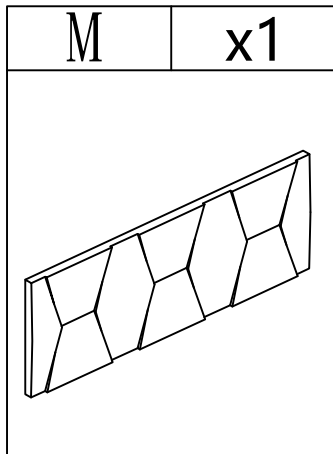
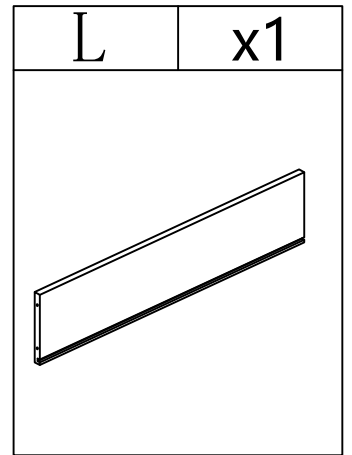
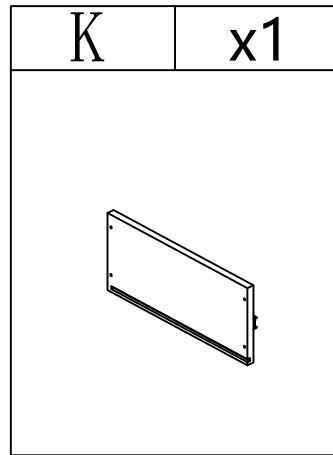
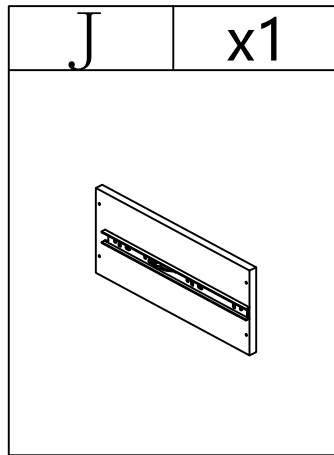
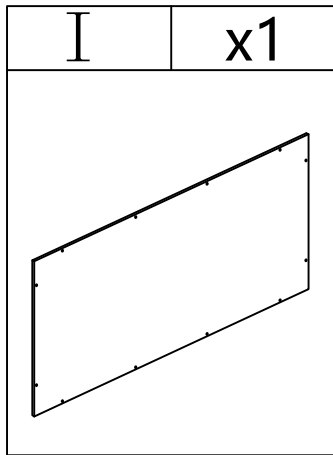
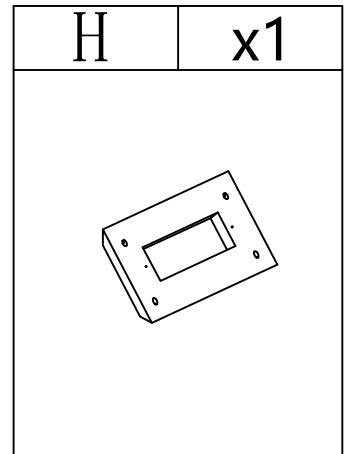
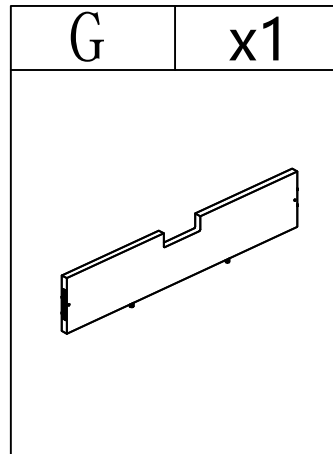
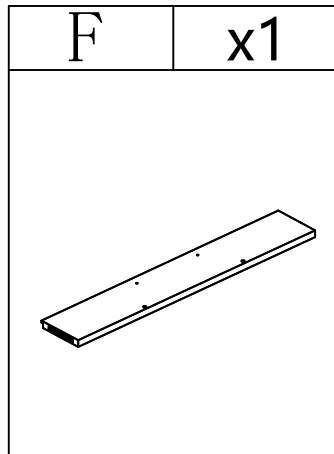
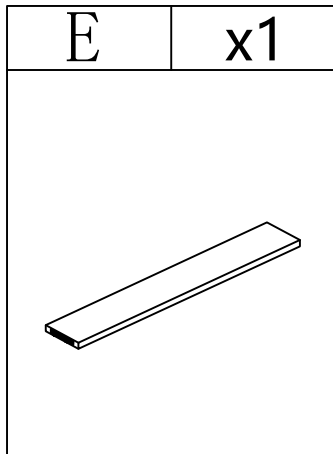
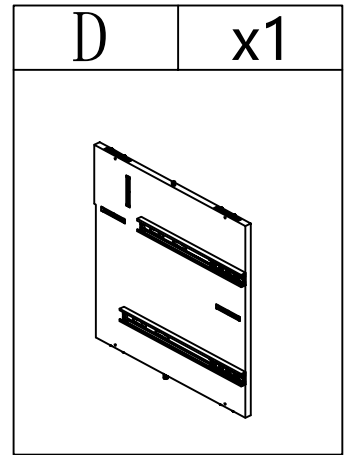
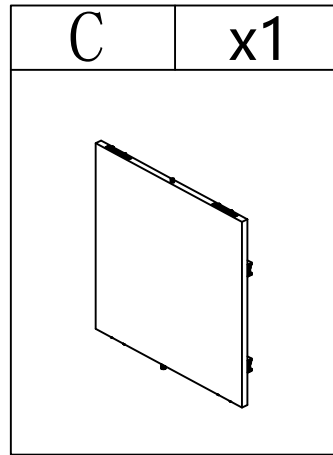
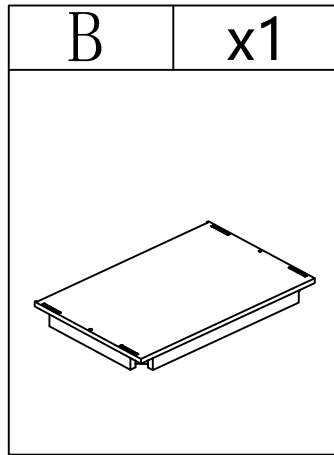
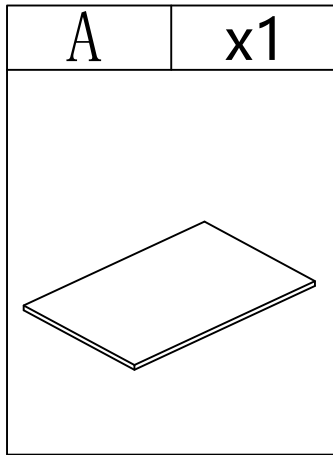

PARTS LIST

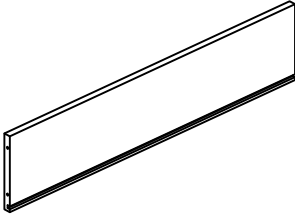

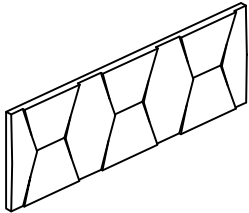

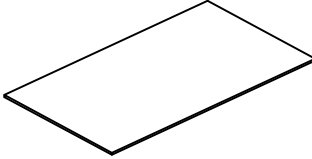



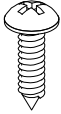

R	x1
	

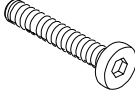
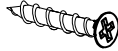
S	x1
	

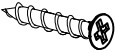
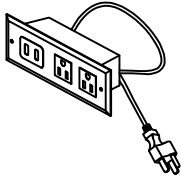
T	x1
	

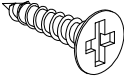
U	x4
	



HARDWARE LIST

#1	x12	#2	x8	#3	x8	#4	x8	#5	x4	#6	x2
											
φ3*14mm		φ1/4"		φ1/4"		φ1/4"*1-3/4"		φ8#*1"		φ3*12mm	
#7	x16	#8	x1	#12	x2	#13	x2	#14	x2	#15	x2
											
φ8#*1"						φ3.5*14mm*6#		φ3.5*35mm*7#			
#16	x1										
											

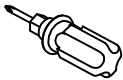
TOOL LIST

#10	x1	#11	x1
			
M4			

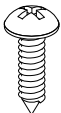
HARDWARE SPARE LIST

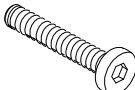
#1	x1	#2	x1	#3	x1	#4	x1
							
φ3*14mm		φ1/4"		φ1/4"		φ1/4"*1-3/4"	

ASSEMBLY INSTRUCTIONS

STEP-1

1. Insert part (G) into part (F), make sure all holes align .

2.1. Insert panel (F&G&E) into side panel (D), make sure all holes aligned and then tighten it with allen key #10 as picture show.

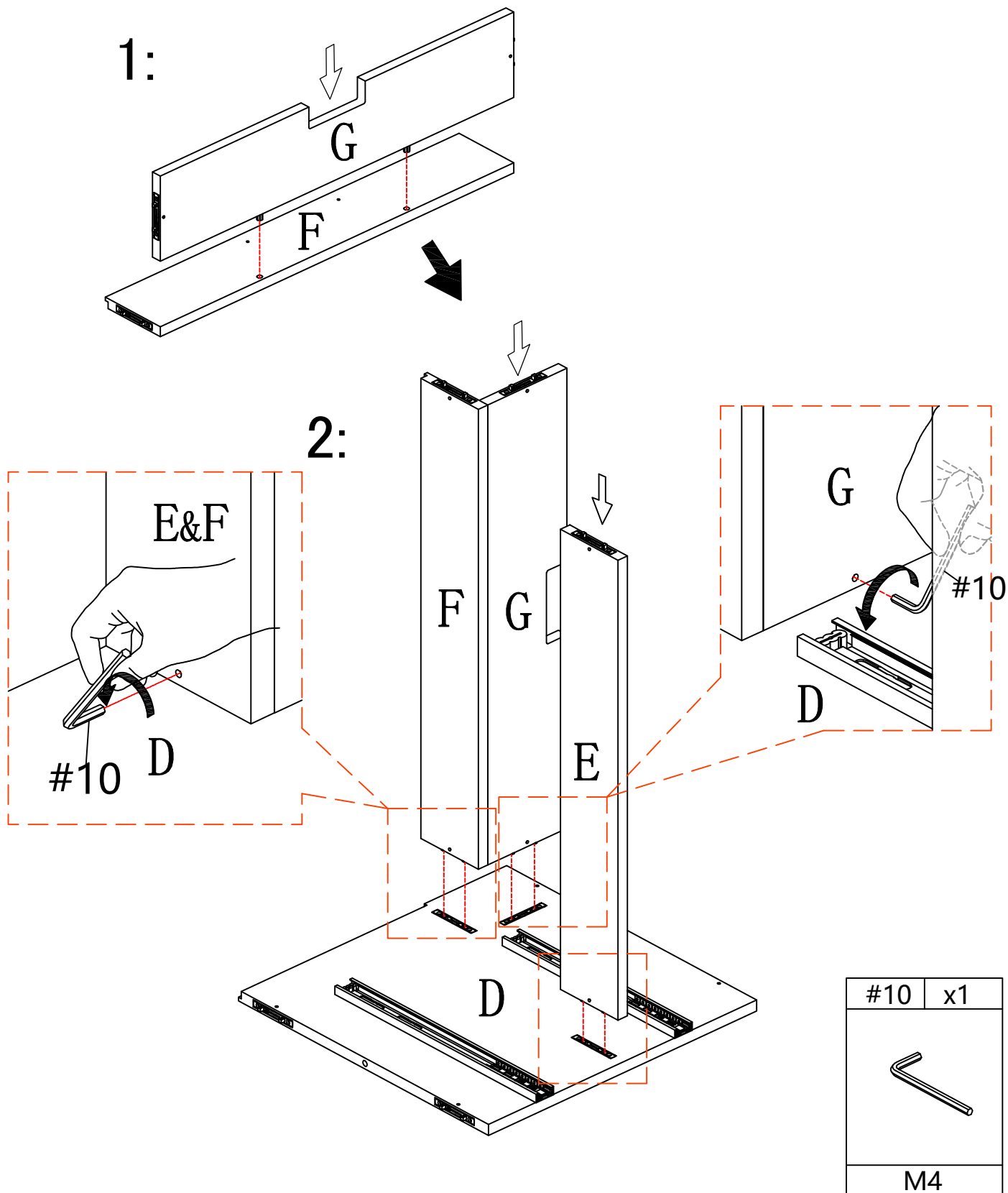

ASSEMBLY INSTRUCTIONS

STEP-2

1. Insert side panel (C) into the corresponding hole of preassembled step 1, make sure all holes aligned and use allen key #10 to tighten it as picture show.

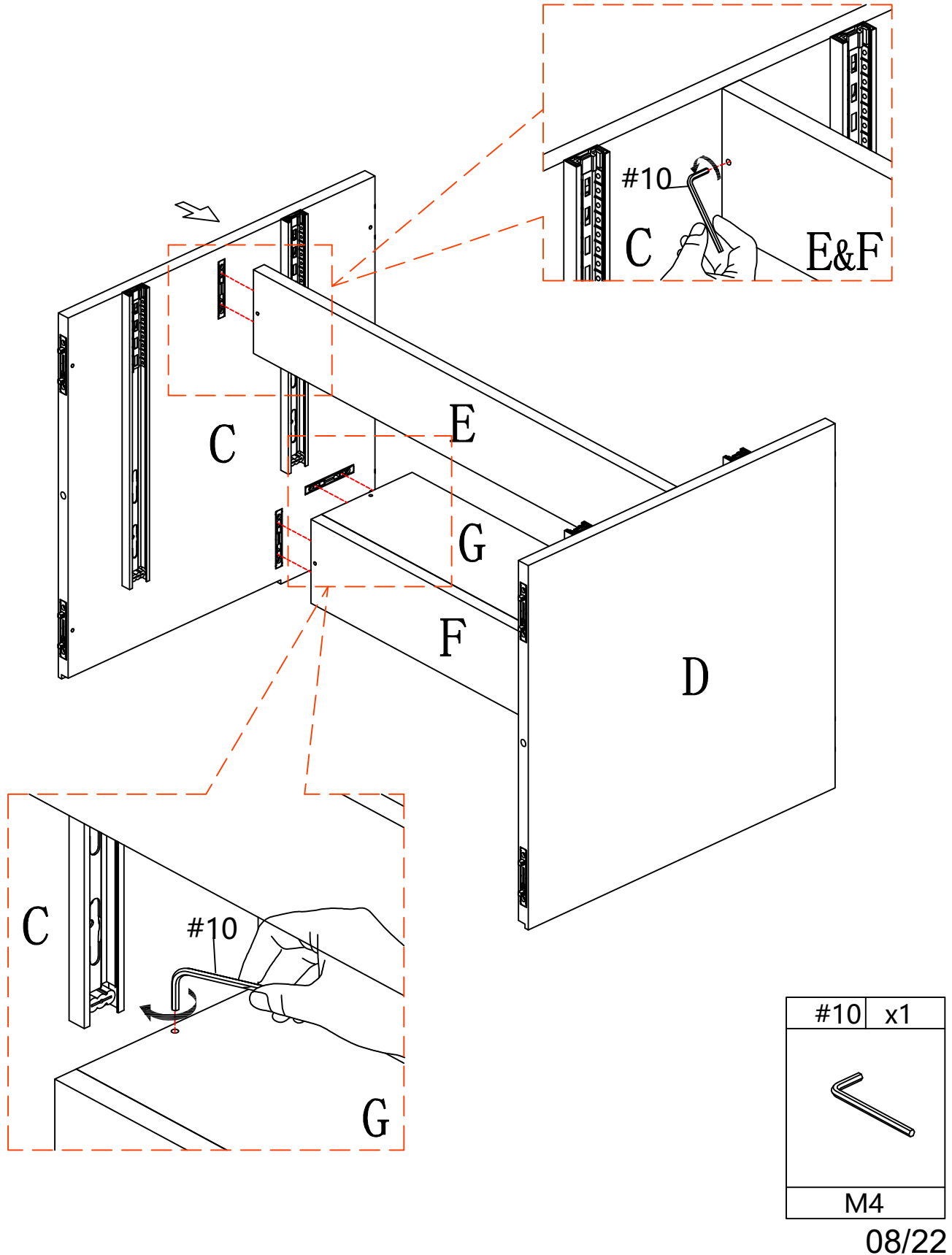



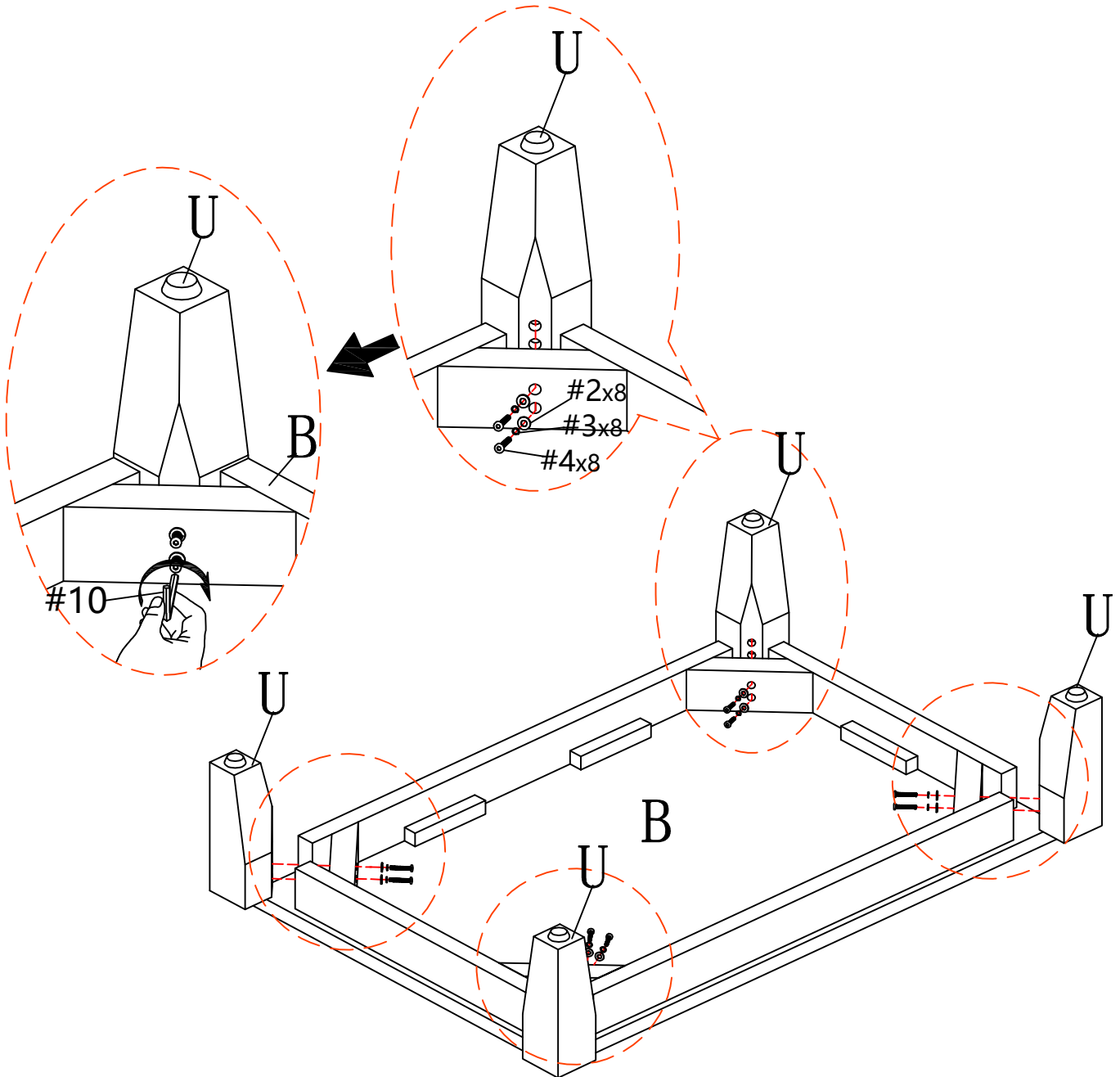

ASSEMBLY INSTRUCTIONS

STEP-3

1. Insert gasket #3 and #2 in sequence into bolt #4, install leg (U) on of bottom panel (B), ensure the corresponding holes are aligned and fix with bolt #4, then tighten the bolt with an Allen key #10.

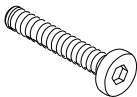

#2	x8	#3	x8	#4	x8	#10	x1
							
φ1/4"		φ1/4"		φ1/4"*1-3/4"		M4	

ASSEMBLY INSTRUCTIONS

STEP-4

1. Insert preassembled step 2 into the corresponding hole of bottom panel (B), make sure all holes aligned and use allen key #10 to tighten it as picture show.

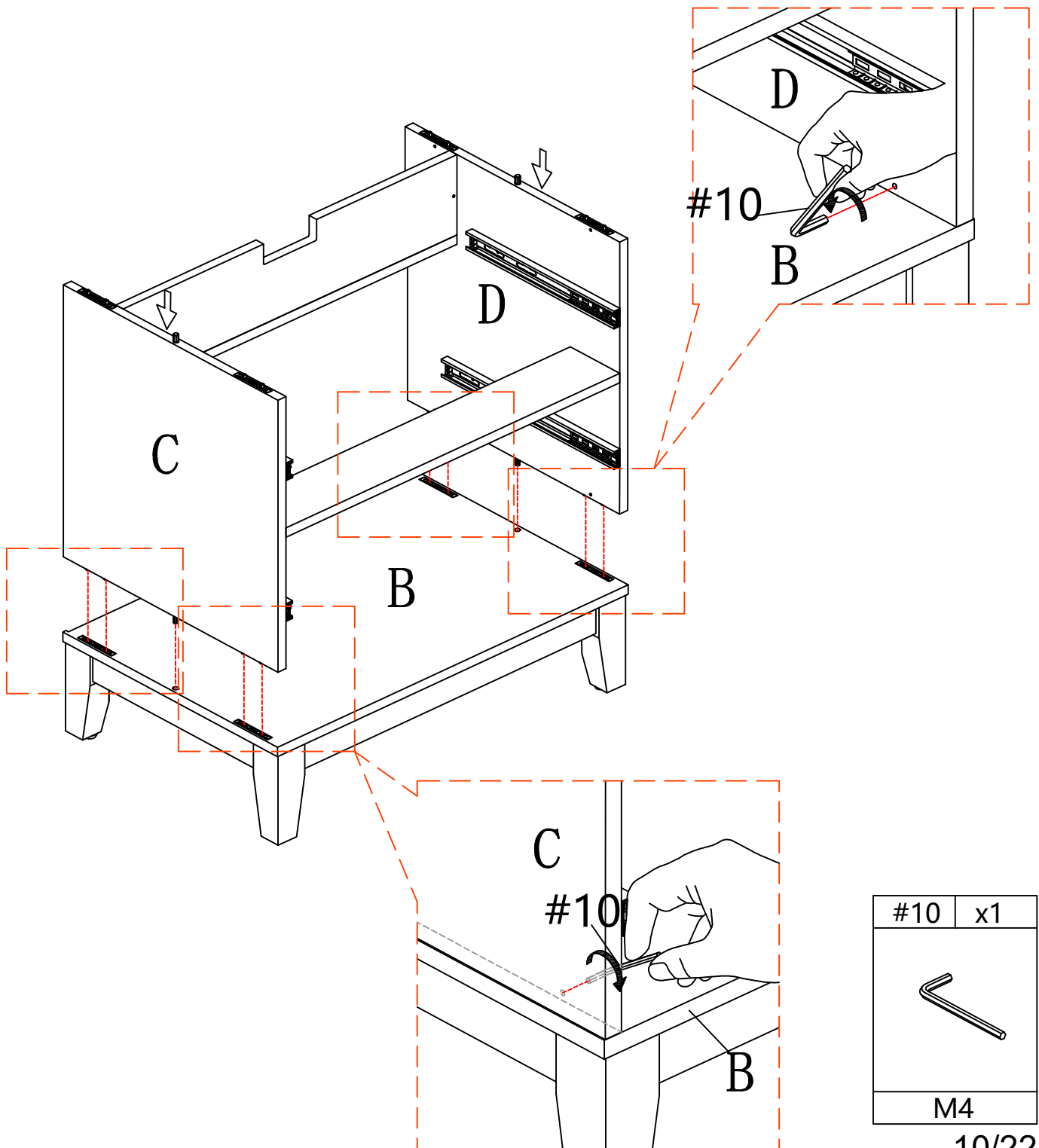

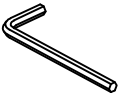
#10	x1
	
M4	

ASSEMBLY INSTRUCTIONS

STEP-5

1.insert back panel (I) into the groove of preassembled step 4,make sure all holes aligned and use screw #1 to attach them , tighten screw #1 with screwdriver #11.

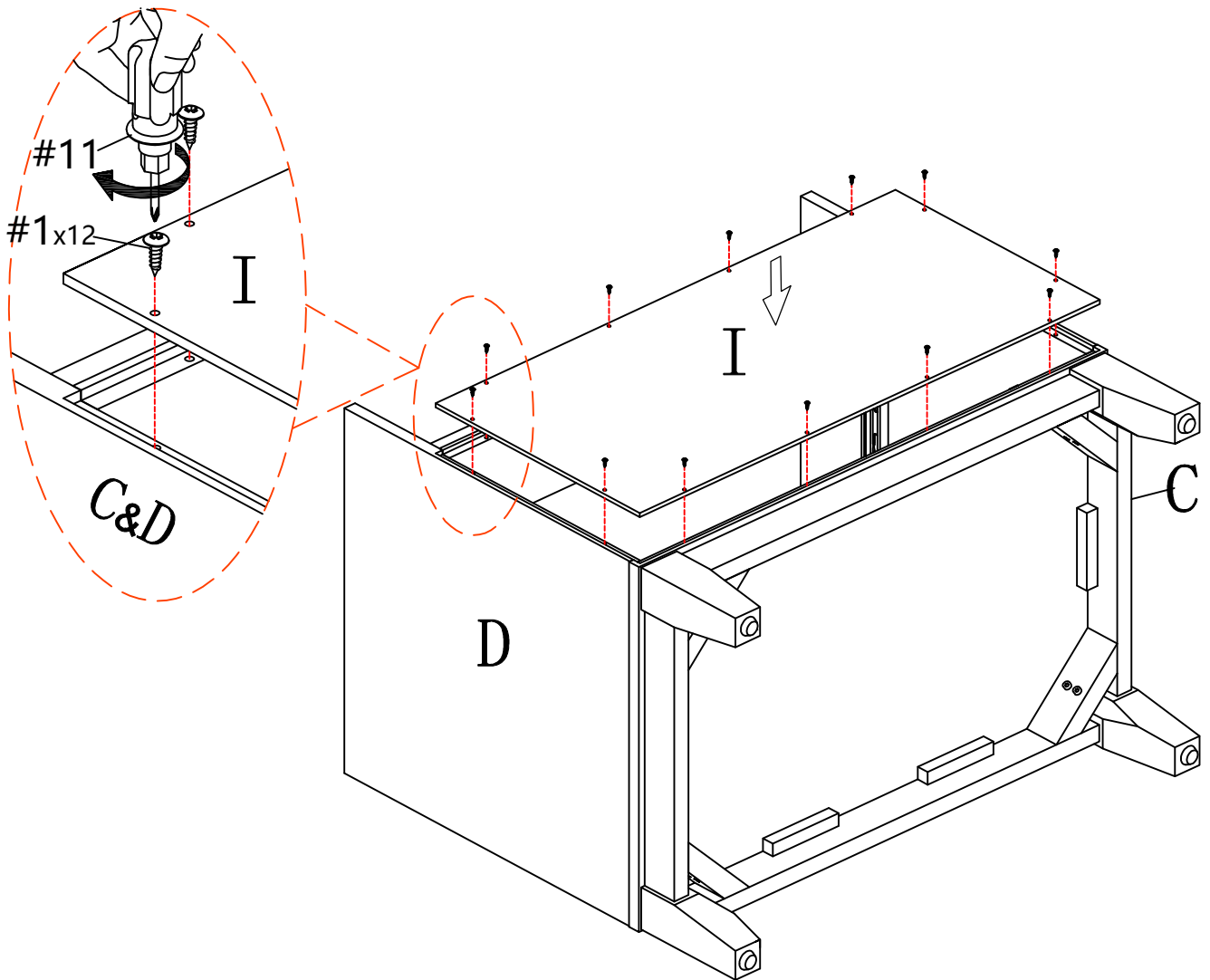

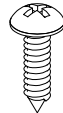
#1	x12
	
ø3*14mm	

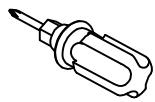
#11	x1
	

ASSEMBLY INSTRUCTIONS

STEP-6

1.insert part (H) into the preassembled step 5,make sure all holes aligned and use screw #5 to attach them , tighten screw #5 with screwdriver #11.

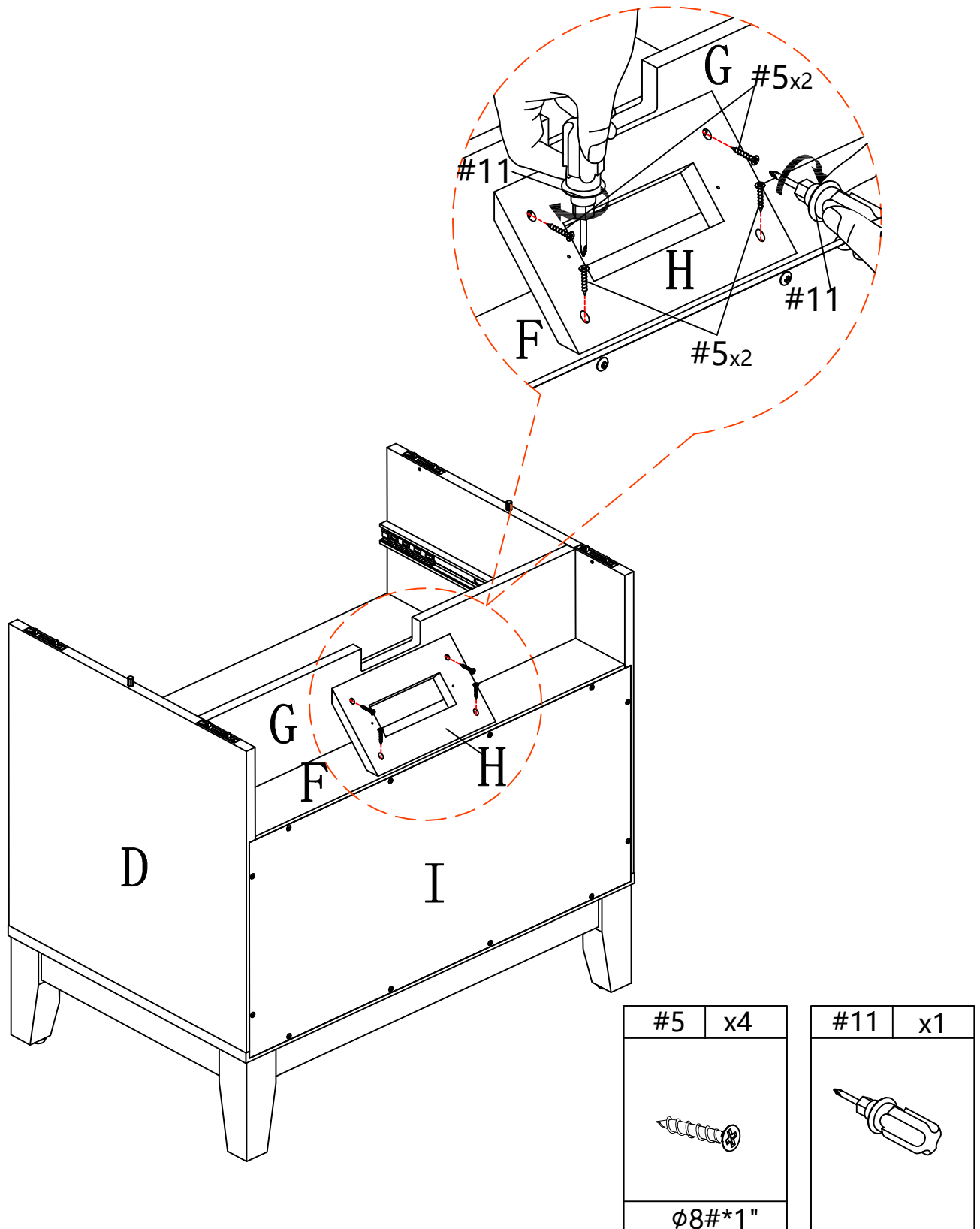

ASSEMBLY INSTRUCTIONS

STEP-7

1.insert part #8 into the preassembled step 6,make sure all holes aligned and use screw #6 to attach them , tighten screw #6 with screwdriver #11.

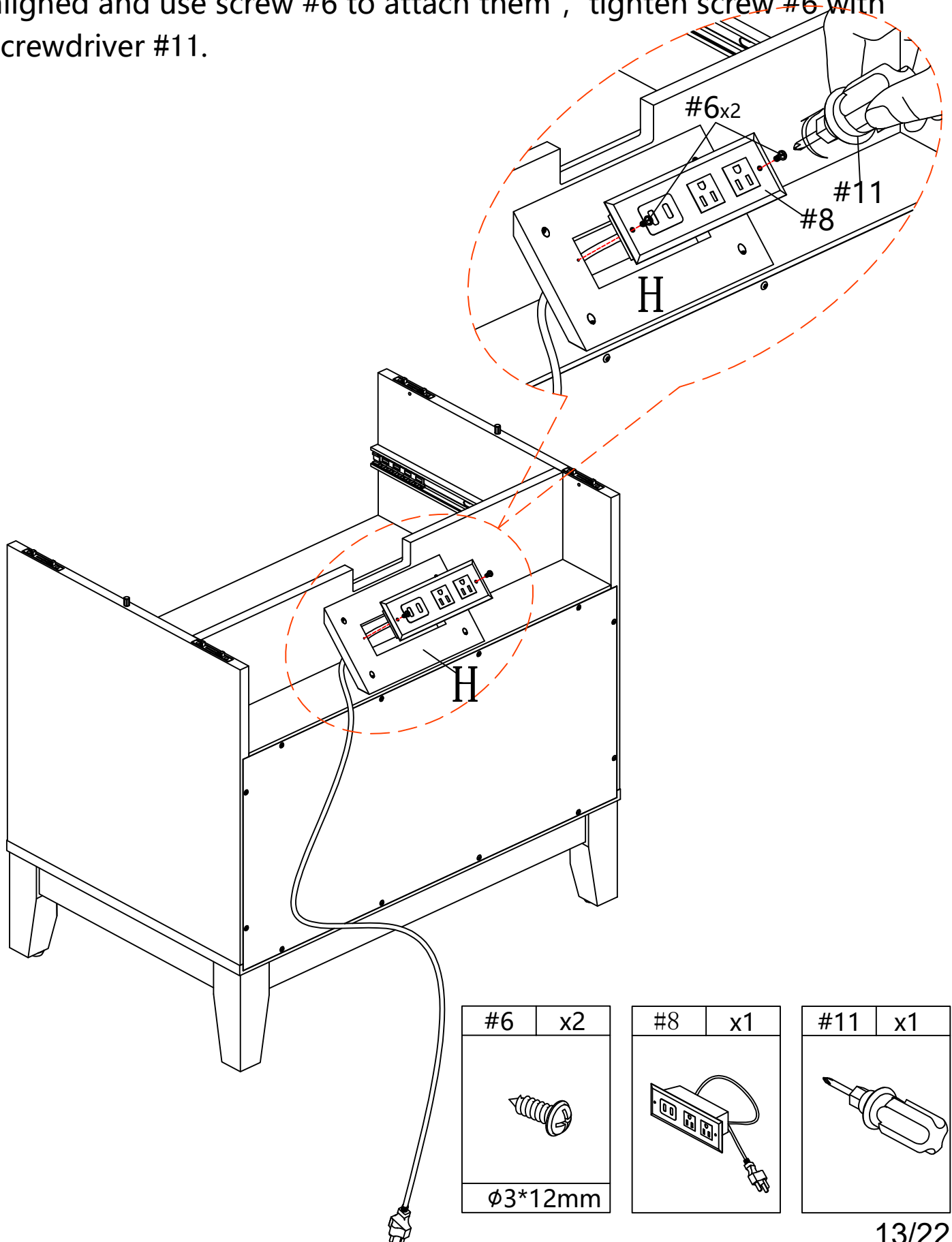

ASSEMBLY INSTRUCTIONS

STEP-8

1. Insert top panel (A) into the corresponding hole of preassembled step 7, make sure all holes aligned and use allen key #10 to tighten it as picture show.

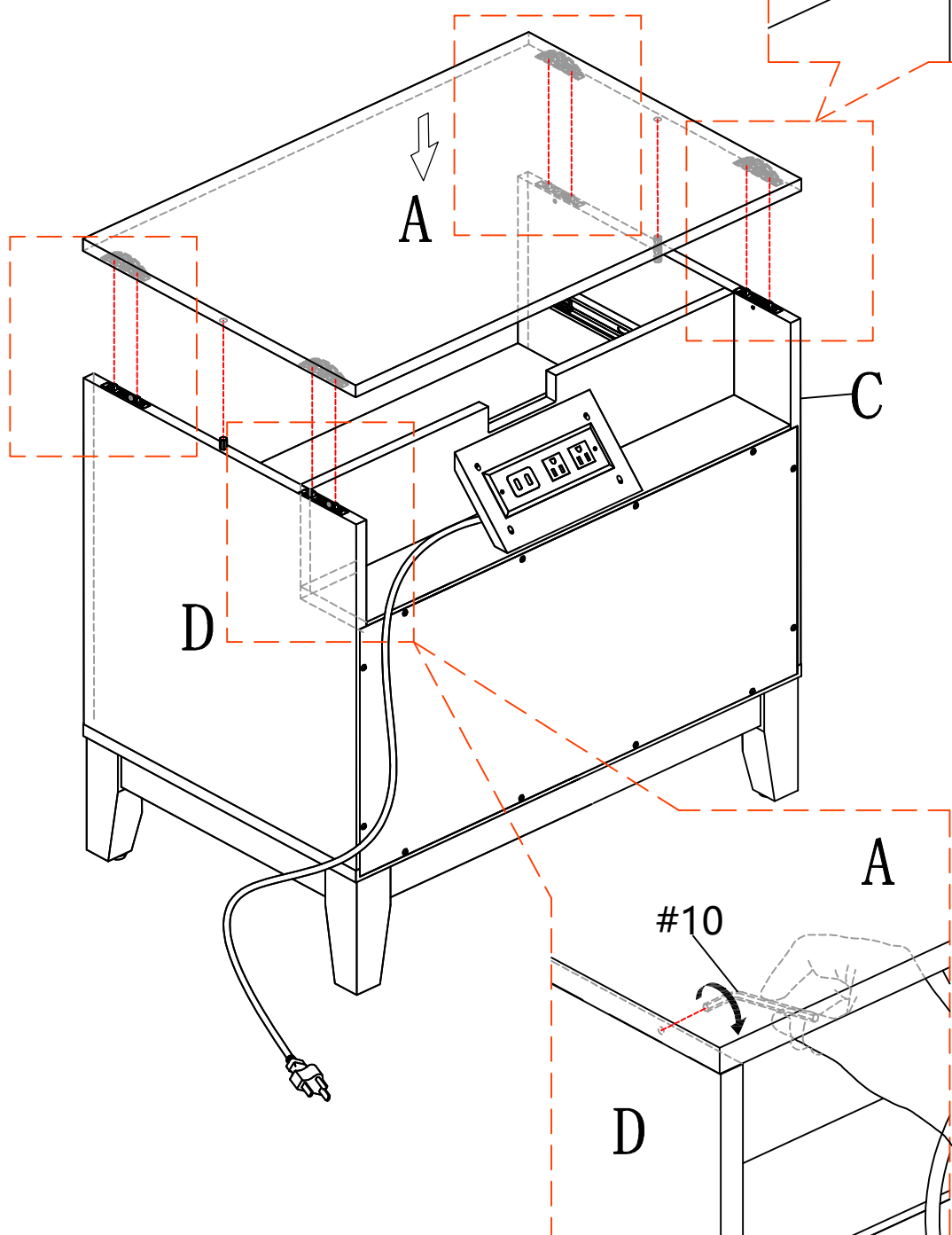
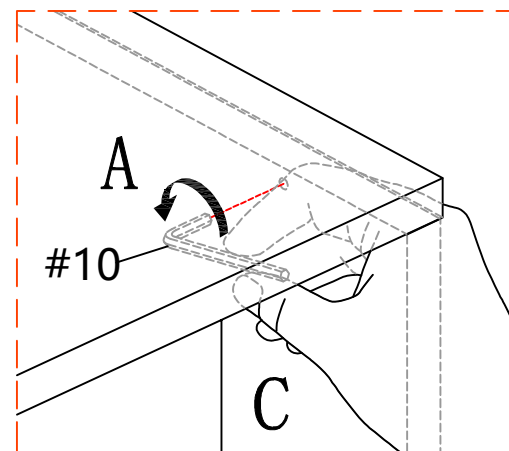

#10	x1
	
M4	



ASSEMBLY INSTRUCTIONS

STEP-9

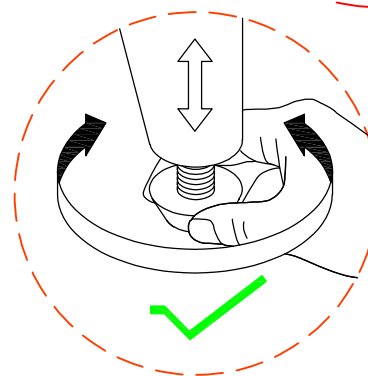
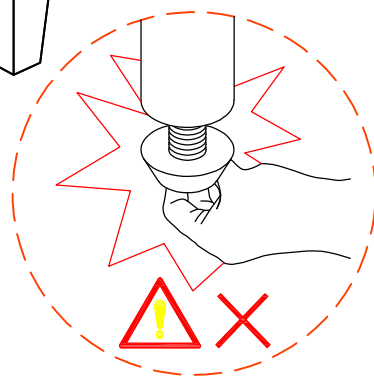
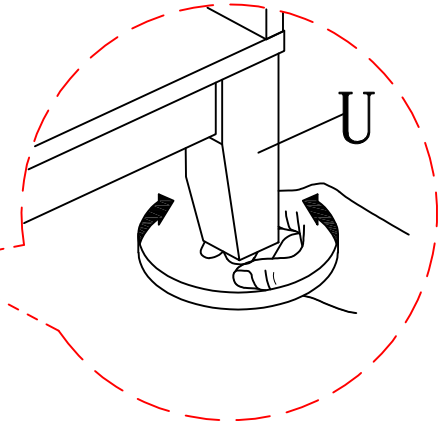
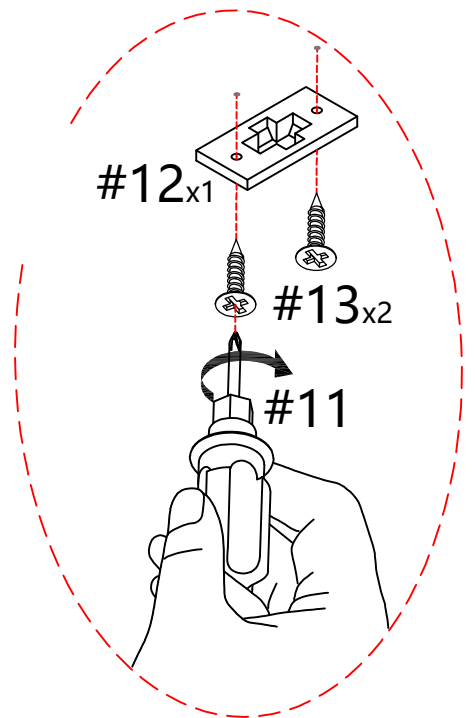
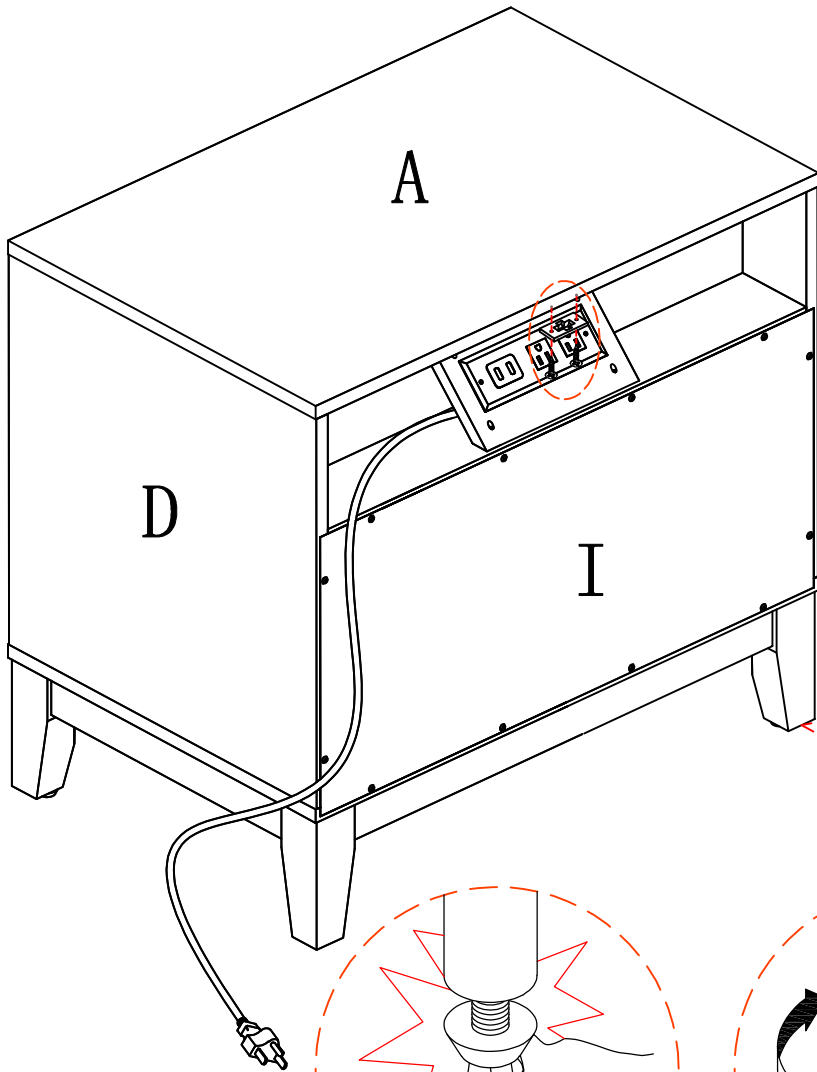
1. connect part #12 to top panel(A) with screw #13, tight screw with screwdriver #11.

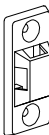

Attention:
Before the next step, adjust the feet of the locker to keep it level.

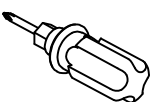
#12	x1	#13	x2	#11	x1
					
		φ3.5*14mm*7#			

ASSEMBLY INSTRUCTIONS

STEP-10

1. Connect part (J&K) to part (M) using screw #7 and tighten it with screwdriver #11. Slide in the part (N) into the groove in part (J&K). make sure they are also in groove in part (M).

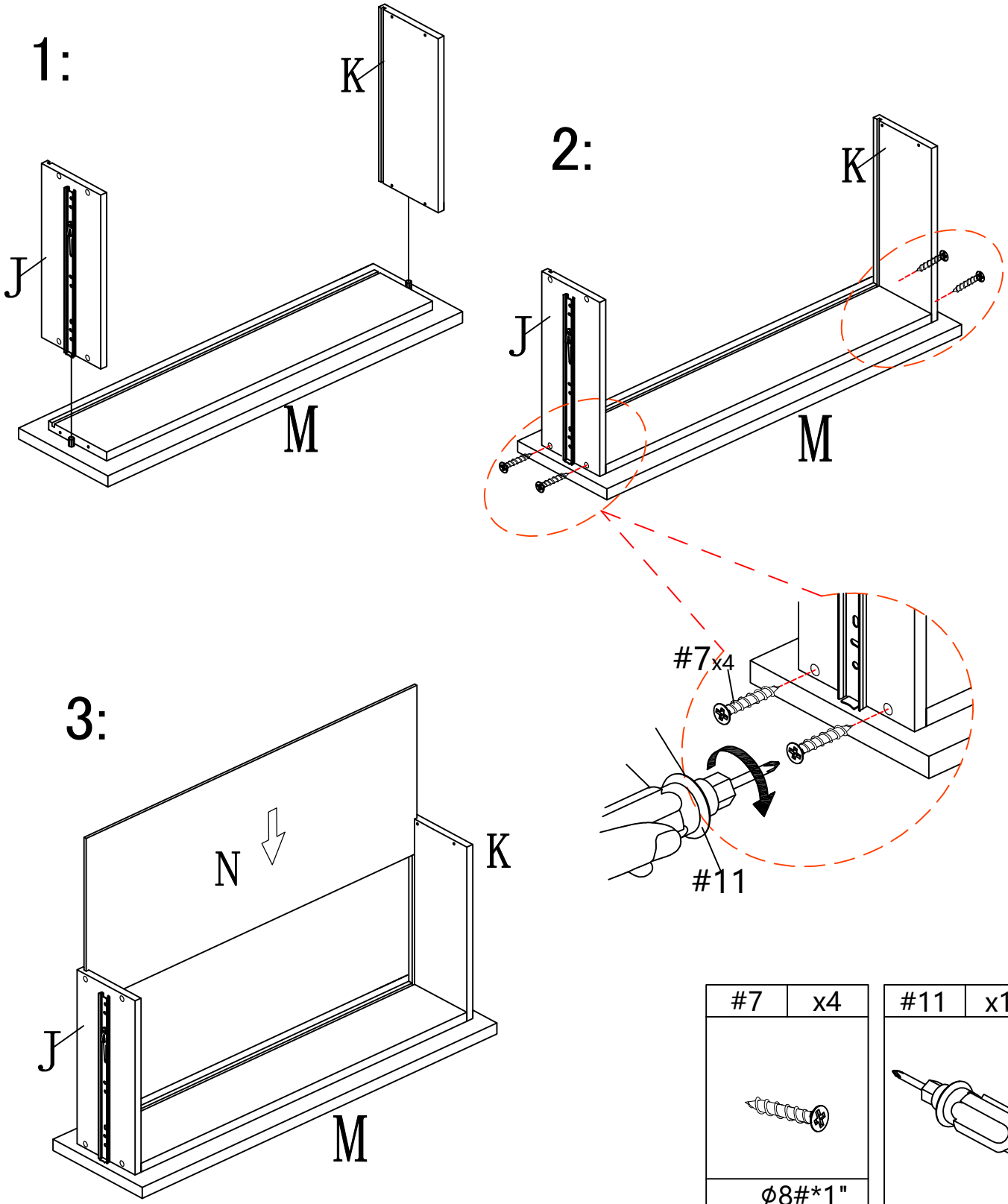

ASSEMBLY INSTRUCTIONS

STEP-11

1. Connect part (O&P) to part (S) using screw #7 and tighten it with screwdriver #11. Slide in the part (T) into the groove in part (O&P). make sure they are also in groove in part (S).

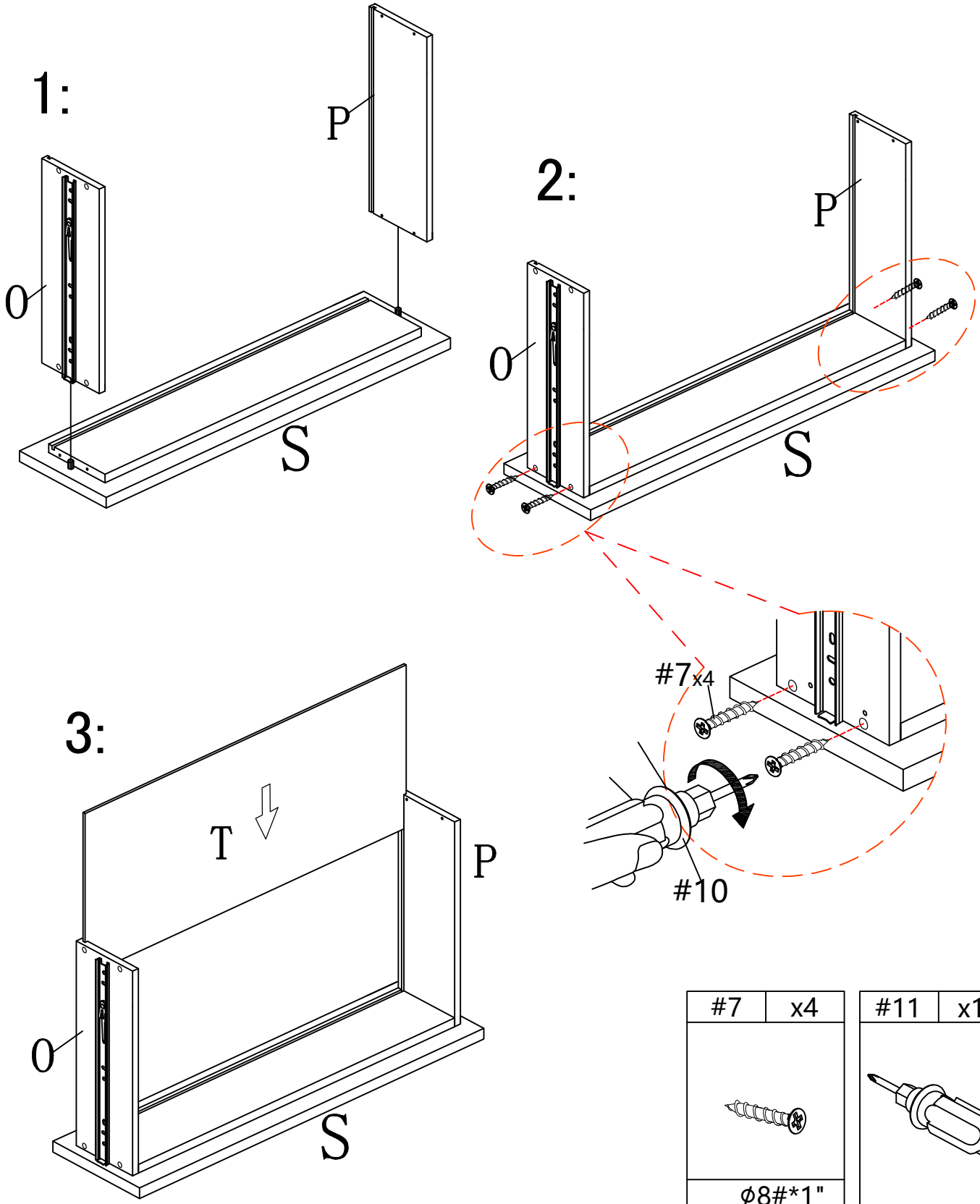

ASSEMBLY INSTRUCTIONS

STEP-12

1. Connect the (L) connection (J&K) using screw #7 , and tighten it with screwdriver #11.
2. Connect the (R) connection (O&P) using screw #7 , and tighten it with screwdriver #11.

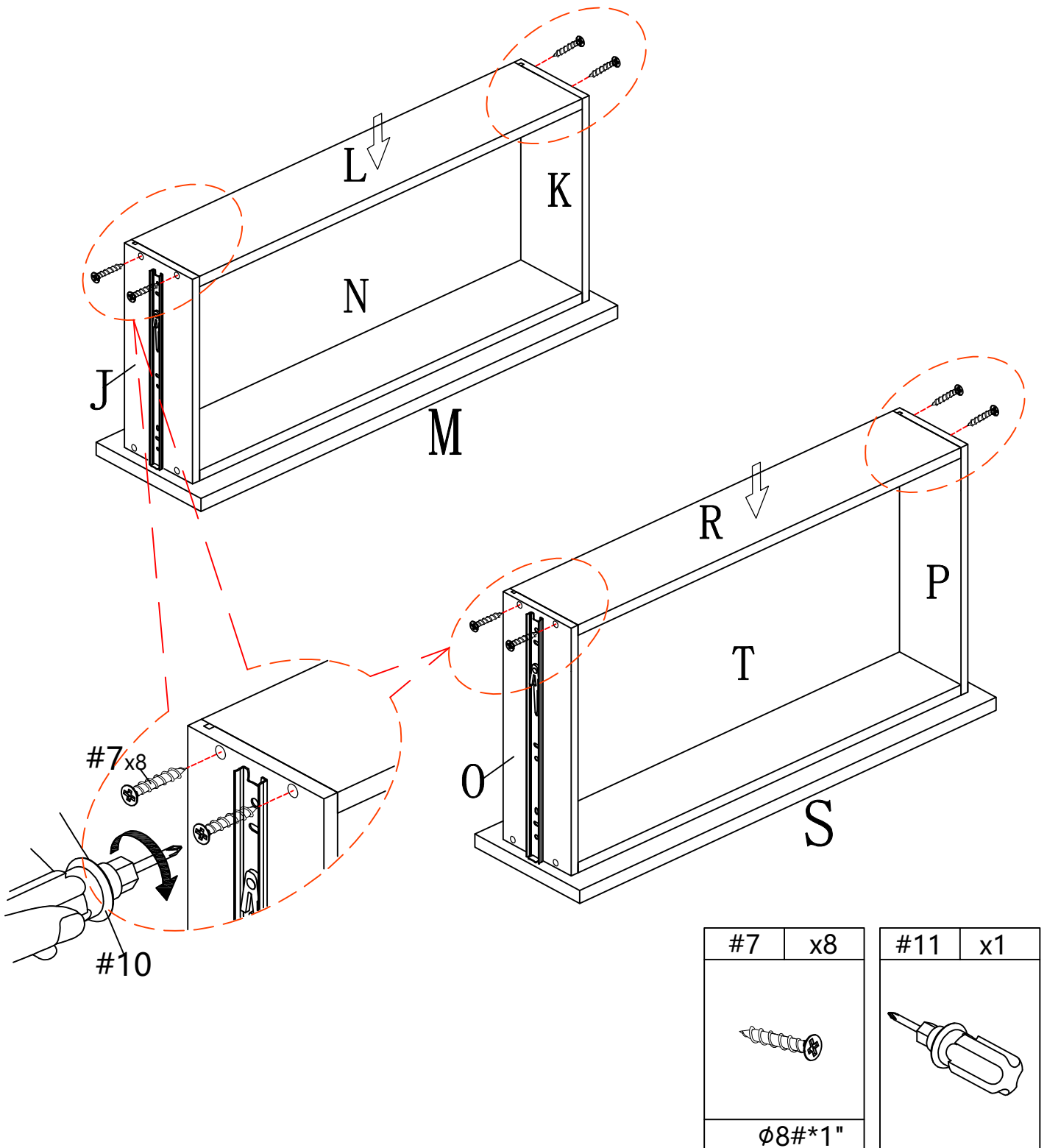

ASSEMBLY INSTRUCTIONS

STEP-13

Attach drawer to preassemble unit at step 12.

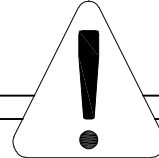

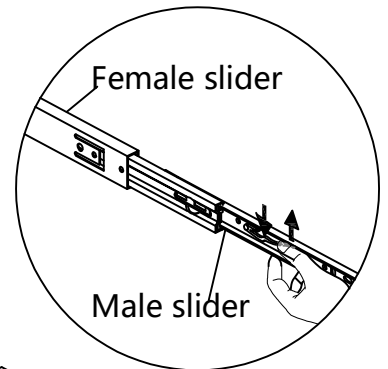
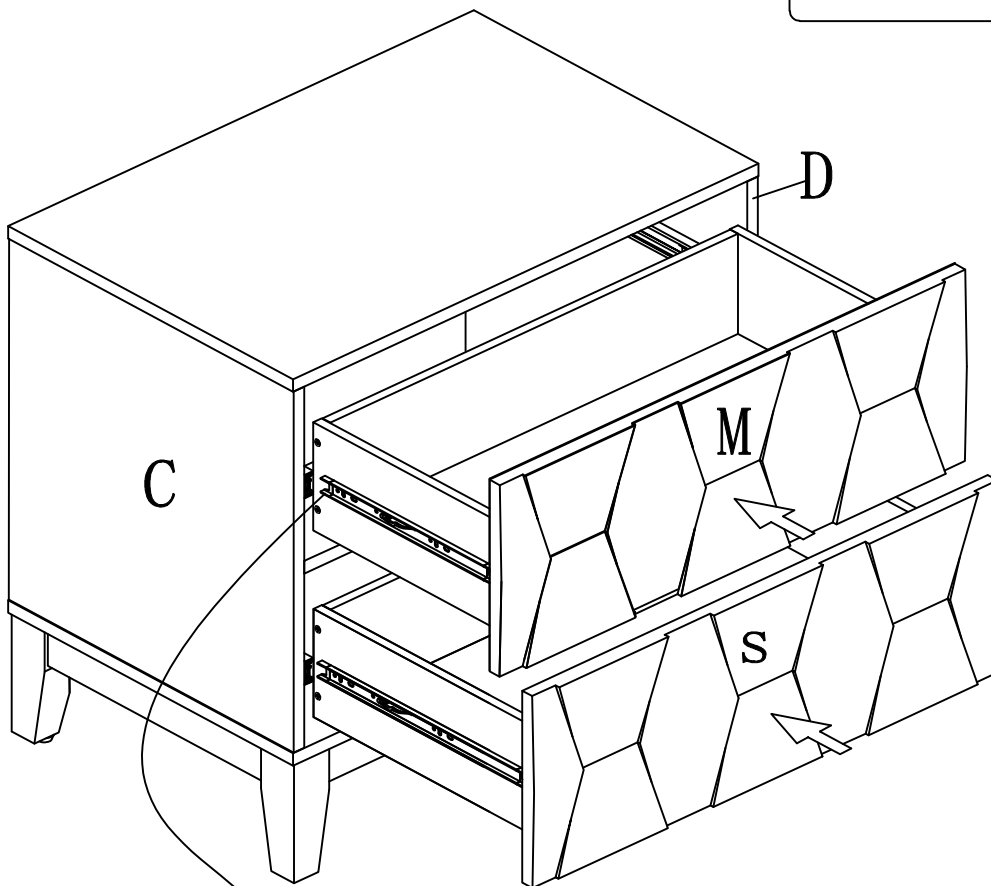

Attention: When installing the drawer, slide the steel ball side rail of side panel to the most front as picture show.

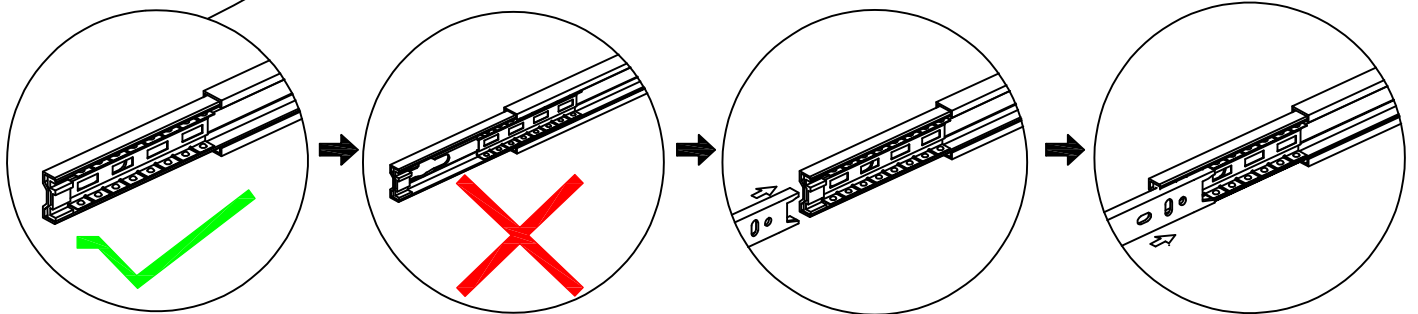

Schematic diagram of slide rail disassembly

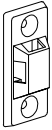

ASSEMBLY INSTRUCTIONS

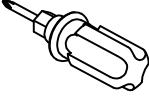
#12	x1	#14	x2	#15	x2	#11	x1
							
		Ø3.5*35mm*7#					

STEP-14

1. Install the anti-collapse device.
2. Mark the position on the wall, that corresponds to the location of part (#12) on the Top panel (A); Drill and insert the expandable screw (#15) by hammer.
3. Assemble the part (#12) to the well. Align the hole in the part (#12) with the expandable screw (#15), use screw (#14) to attach it and tighten by screwdriver (#11)

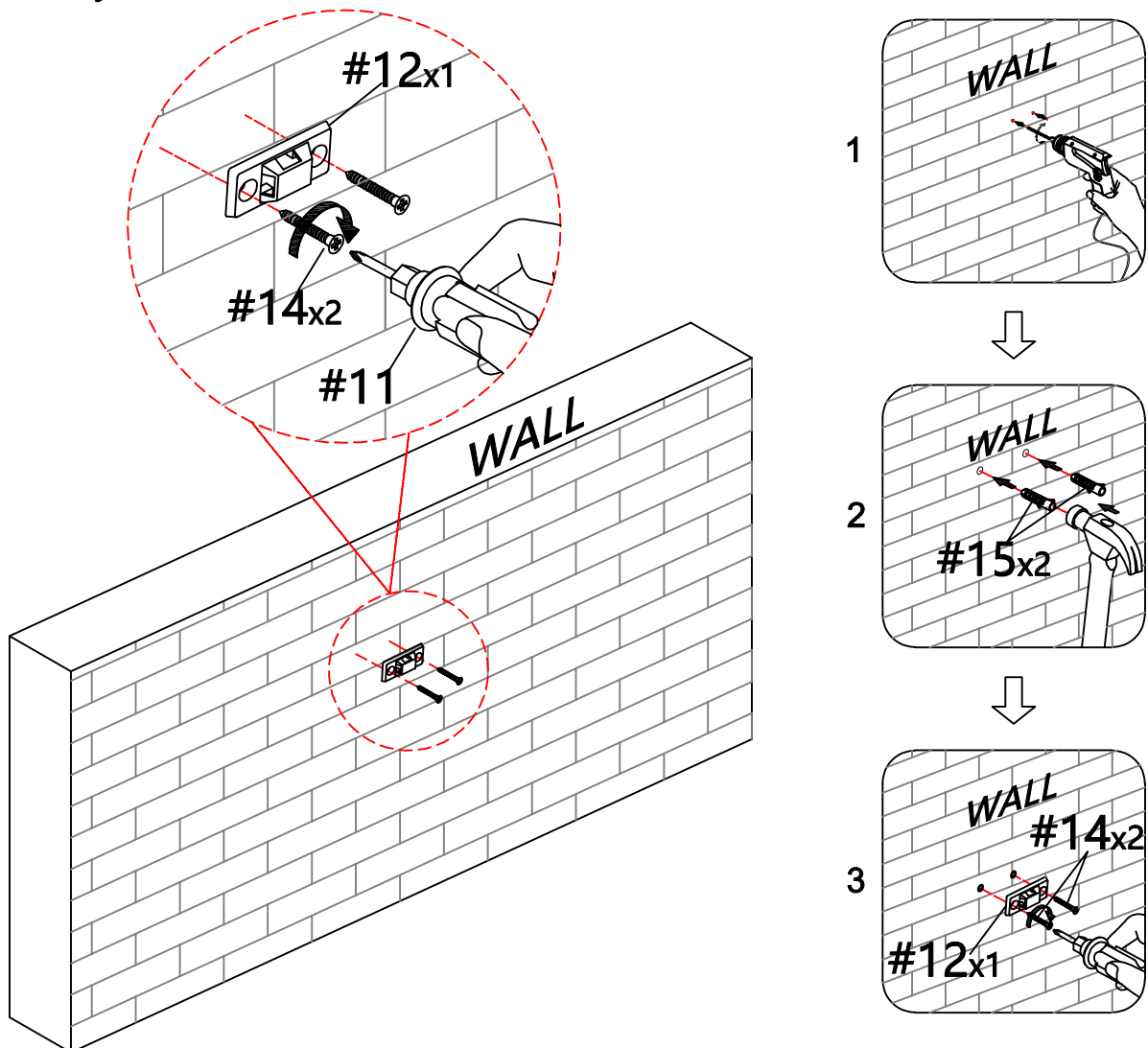

ASSEMBLY INSTRUCTIONS

#16 x1

STEP-15

1. Let the plastic belt (#16) pass through the both part (#12) and pull tightly.

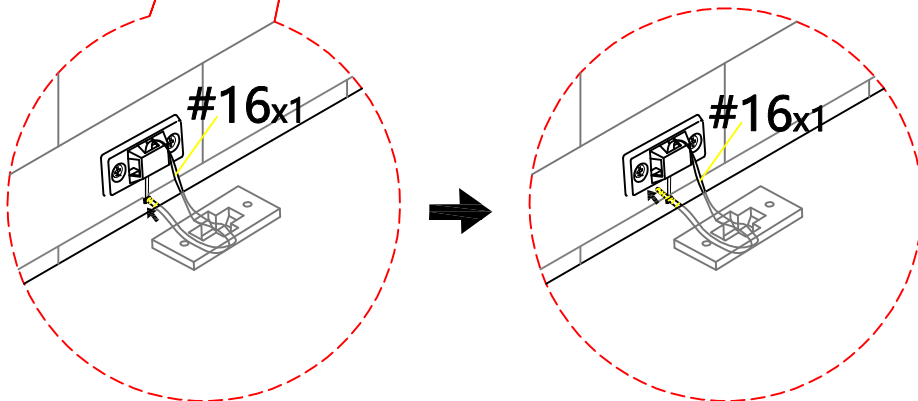
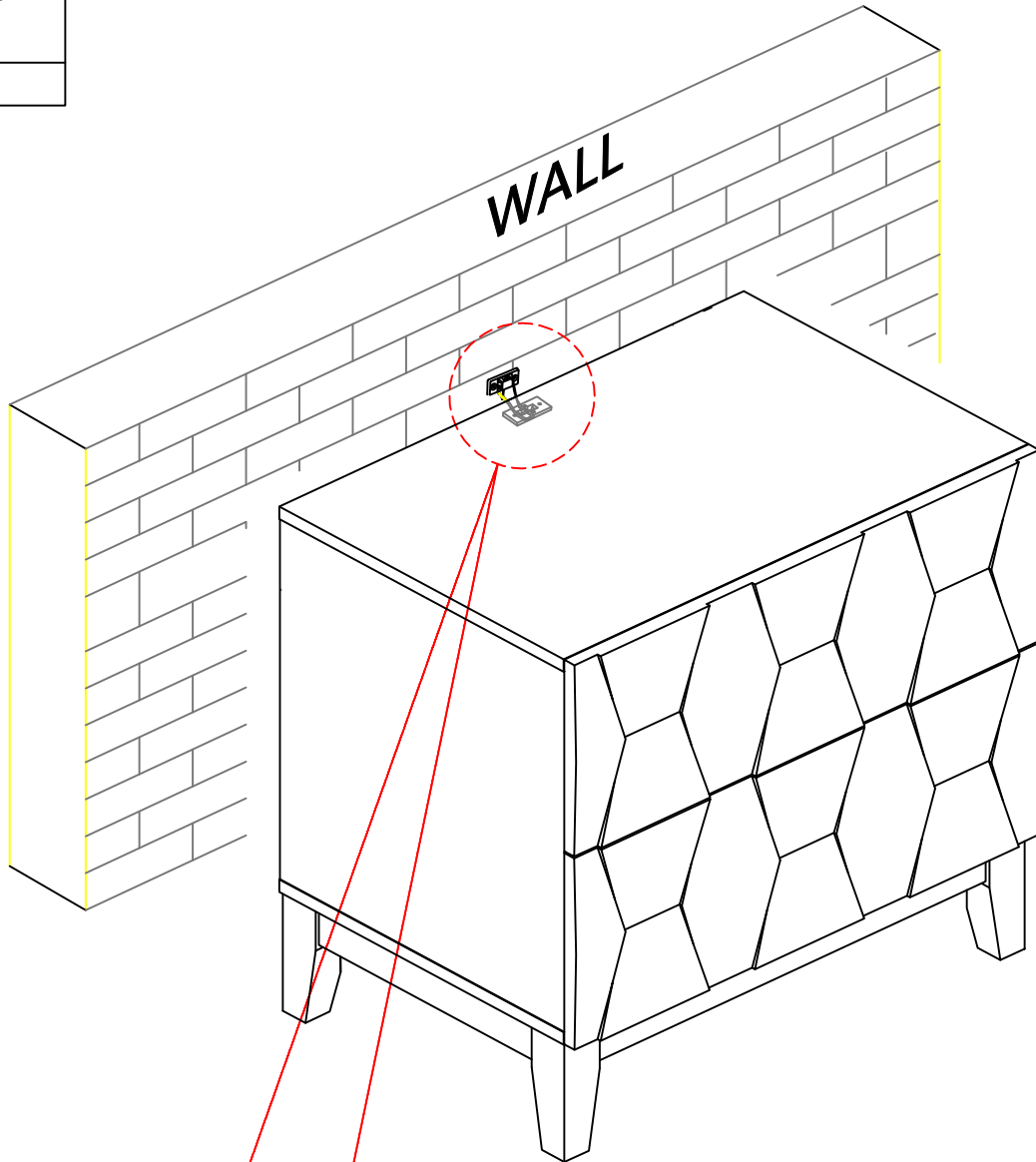
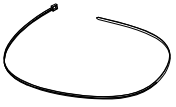

WARRANTY

1. We strive to offer high-quality products, and we also try our best to satisfy each and every customer that orders from us with product or service as needed.
2. We provide 30 days warranty starting from the time you receive the item. Each customer must provide a record of their order such as the order number, or item receipt for any items that are out of the warranty period you may also still receive.
3. Replacement parts by purchasing them with our company if they are available.