

B E R N H A R D T

ASSEMBLY INSTRUCTIONS FOR

398-H04/FR4 5/0 UPH BED
 398-H05/FR5 6/6 UPH BED
 398-H06/FR6 6/0 UPH BED

Thank you for purchasing Bernhardt Furniture. Be sure to check all packing materials carefully to ensure proper assembly.

Please read all instructions carefully before starting the assembly process. Some parts are large and heavy and require at least two people to assemble, to prevent possible injury and/or damage to furniture.

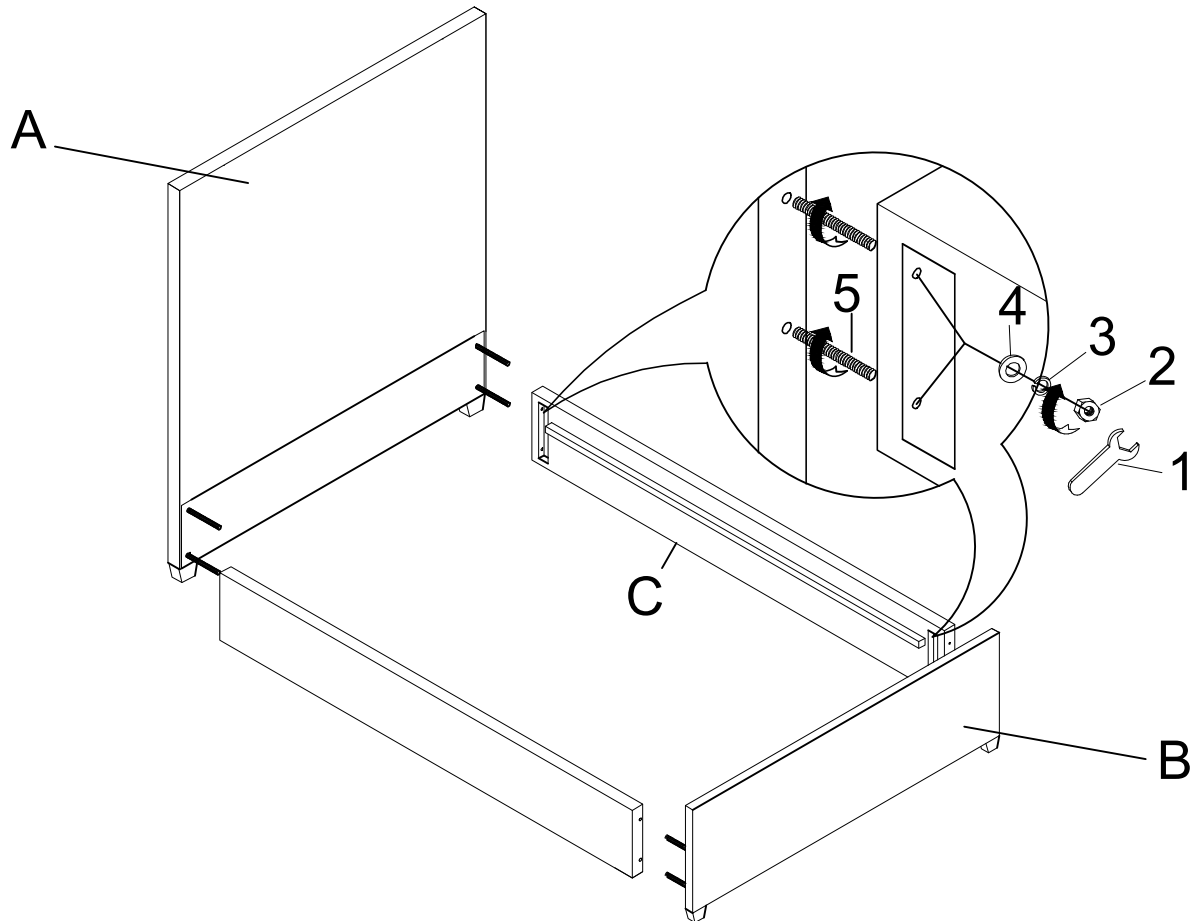

PARTS LIST

| NO. | DRAWING | DESCRIPTION | QTY. |
|-----|---------|-------------|--------|
| A | | HEADBOARD | 1 PC |
| B | | FOOTBOARD | 1 PC |
| C | | SIDERAIL | 2 Pcs |
| D | | SLAT | 5 Pcs |
| E | | SUPPORT LEG | 10 Pcs |

| NO. | DRAWING | DESCRIPTION | SIZE | QTY. |
|-----|---------|--------------|----------------|--------|
| 1 | | Open Wrench | M12 | 1 PC |
| 2 | | Hex Nut | 5/16" | 8 Pcs |
| 3 | | Lock Washer | 5/16" | 8 Pcs |
| 4 | | Flat Washer | 5/16" | 8 Pcs |
| 5 | | Threaded Rod | 5/16" x 3 1/2" | 8 Pcs |
| 6 | | Screw | M4 x 1 1/4" | 10 Pcs |

ASSEMBLY INSTRUCTIONS

- Stand Headboard and Footboard in upright position and attach Threaded Rod (5) into all attachment locations. See diagram. 2 holes for Threaded Rods are located on each end of Headboard and Footboard.
- Carefully slide Siderails (C) onto Threaded Rods on Headboard and Footboard. Place Flat Washer (4), Lock Washer (3) and Hex Nut (2) onto Threaded Rod in Siderail cavity.
- Tighten Hex Nuts using Open Wrench (1).

B E R N H A R D T

ASSEMBLY INSTRUCTIONS FOR

398-H04/FR4
398-H05/FR5
398-H06/FR6

5/0 UPH BED
6/6 UPH BED
6/0 UPH BED

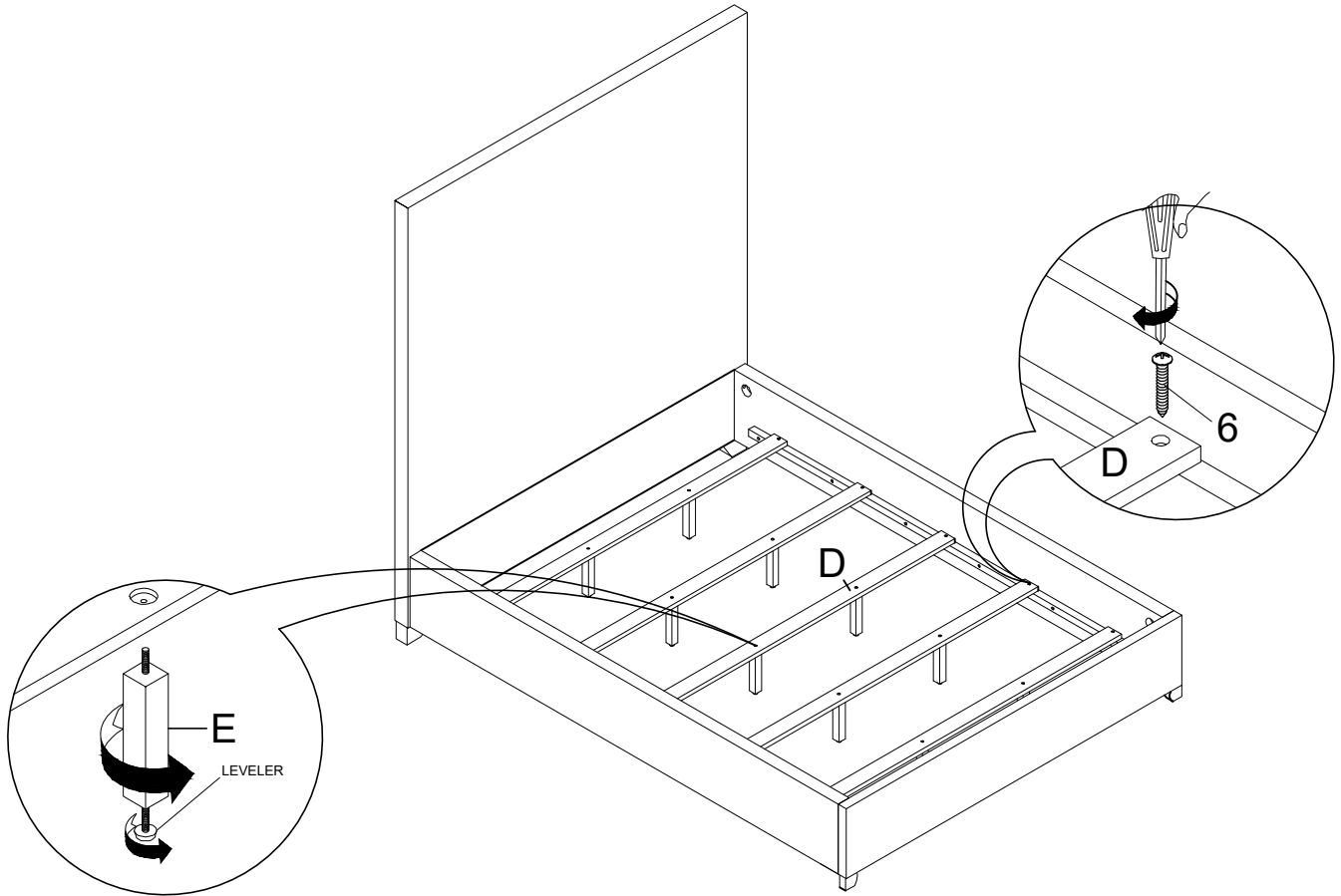

PARTS LIST

| NO. | DRAWING | DESCRIPTION | QTY. |
|-----|---------|-------------|--------|
| A | | HEADBOARD | 1 PC |
| B | | FOOTBOARD | 1 PC |
| C | | SIDERAIL | 2 Pcs |
| D | | SLAT | 5 Pcs |
| E | | SUPPORT LEG | 10 Pcs |

| NO. | DRAWING | DESCRIPTION | SIZE | QTY. |
|-----|---------|--------------|----------------|--------|
| 1 | | Open Wrench | M12 | 1 PC |
| 2 | | Hex Nut | 5/16" | 8 Pcs |
| 3 | | Lock Washer | 5/16" | 8 Pcs |
| 4 | | Flat Washer | 5/16" | 8 Pcs |
| 5 | | Threaded Rod | 5/16" x 3 1/2" | 8 Pcs |
| 6 | | Screw | M4 x 1 1/4" | 10 Pcs |

NOTE: Philips Screw Driver (Not Included) required for slat assembly.

ASSEMBLY INSTRUCTIONS

1. Attach Support Legs (E) to underside of Slats (D) .
2. Place Slats (D) on Siderails (C), tighten Screw (6) with Phillips Screw Driver.
3. Level bed as needed with adjustable floor glides.