

TWIN BED, PLANK
LITS JUMEAUX EN PLANCHE DE BOIS
CAMA TWIN, CABECERO DE TABLÓN

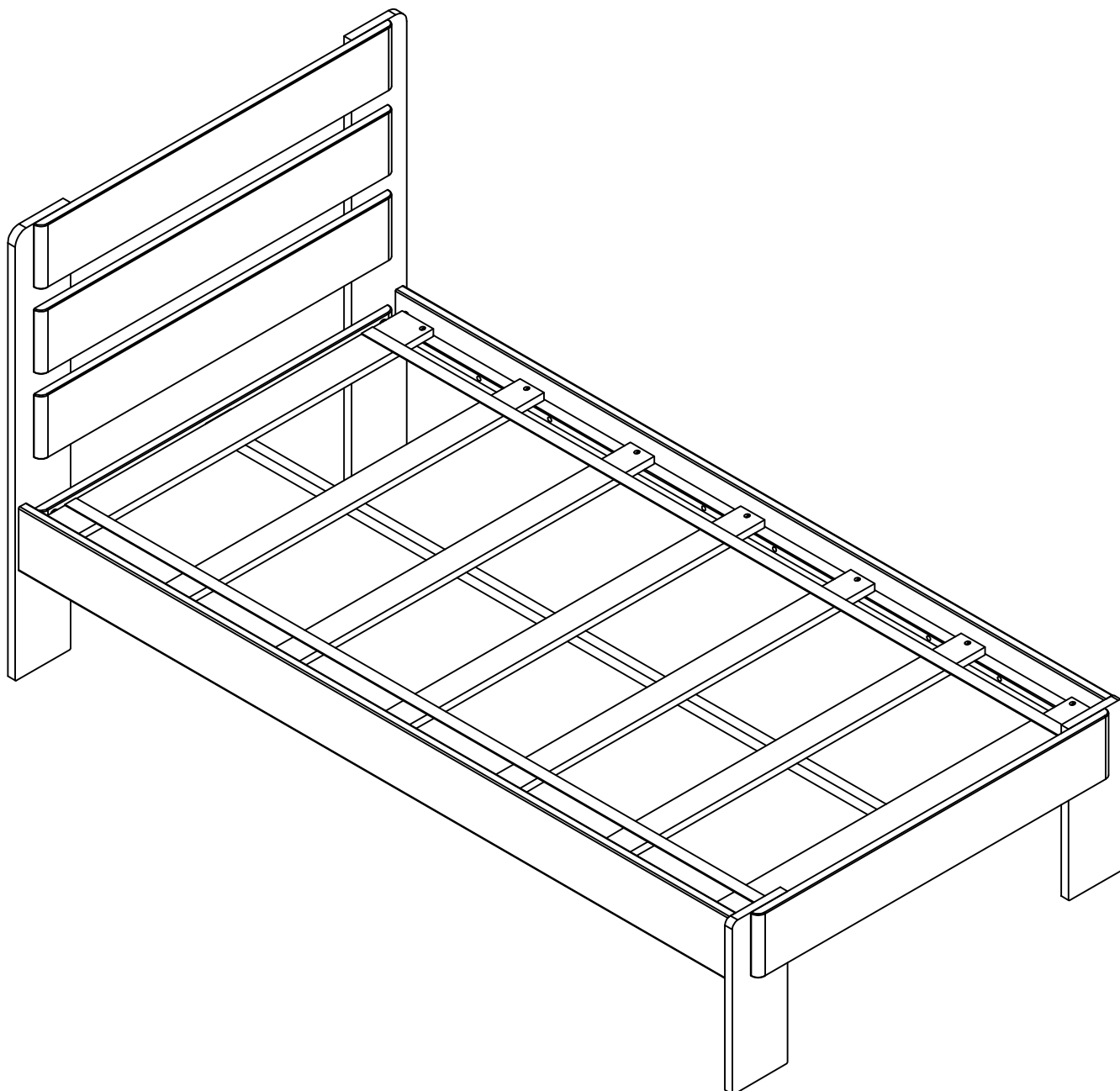

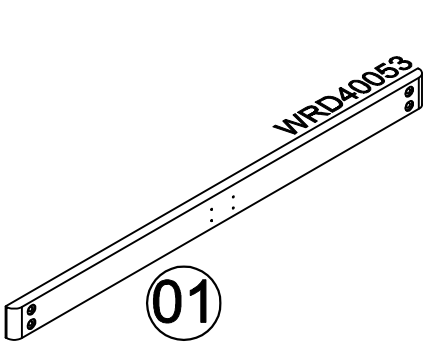

1x

01

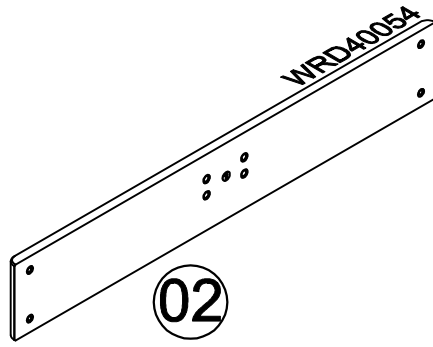

1x

02

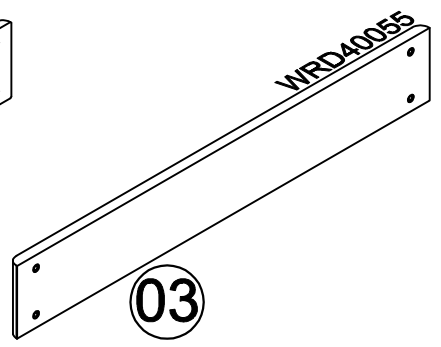

3x

03

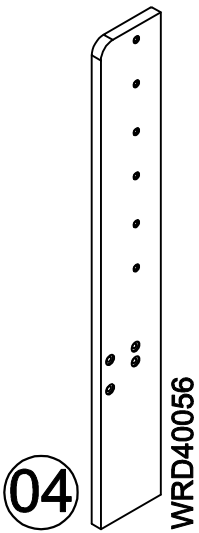

04

1x

WRD40056

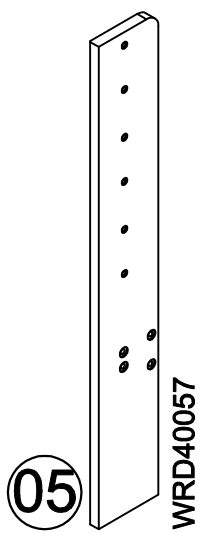

05

1x

WRD40057

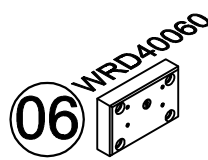

06

1x

WRD40060

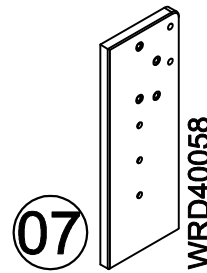

07

1x

WRD40058

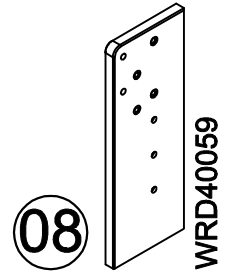

08

1x

WRD40059

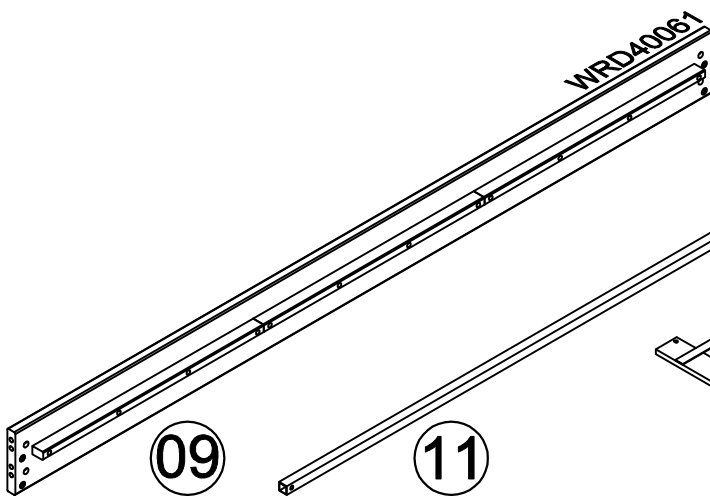

2x

09

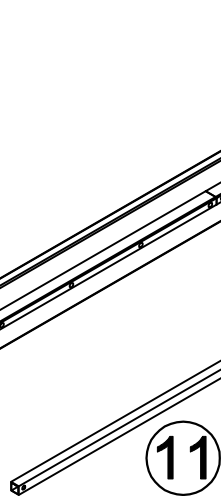

1x

11

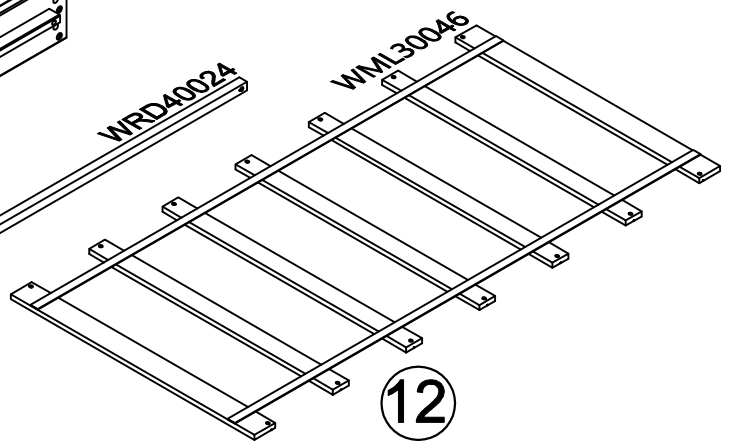

1x

12

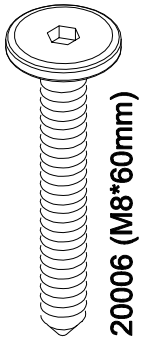

20006 (M8*60mm)

4x



20358 (M8*17mm)

4x

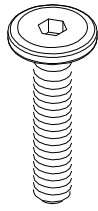

20124 (M6*30mm)

16x

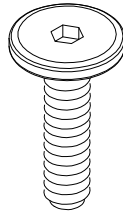

20792 (M8*30mm)

8x

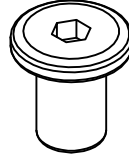

20365 (8*13mm)

4x

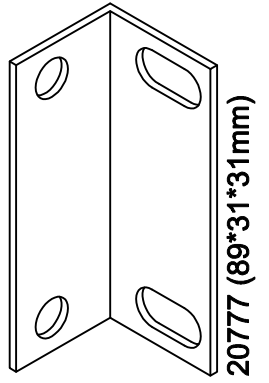

20777 (89*31*31mm)

2x

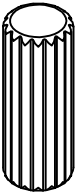

20058 (φ10*30mm)

4x

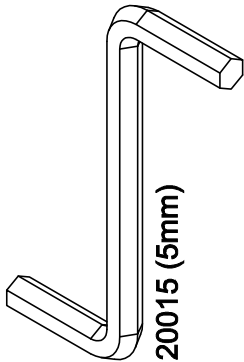

20015 (5mm)

2x

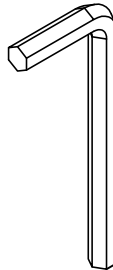

20615 (4mm)

2x

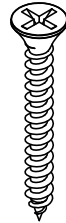

20055 (4*30mm)

14x

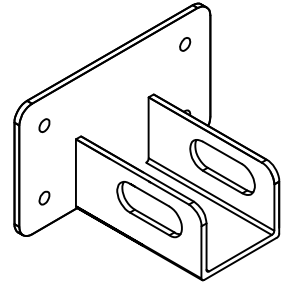

20674 (45*76*25mm)

2x



20010 (3*15mm)

8x

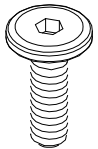

20378 (M6*20mm)

8x

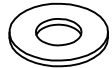

20639 (14*6*1mm)

8x



20129 (6*12*2mm)

8x

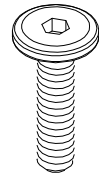

20428 (M6*25mm)

2x



20123 (6*13mm)

2x

⚠ WARNING:

CHOKING HAZARD

Small Parts

Not for children under 3 years.

To be Assembled by an Adult

⚠ ATTENTION:

RISQUE D'ÉTOUFFEMENT

Petites parties

Ne convient pas aux enfants de moins de 3 ans.

Doit être assemblé par un adulte

⚠ ADVERTENCIA

PELIGRO DE ASFIXIA

Partes pequeñas

No apta para niños menores de 3 años

A ser ensamblado por un adulto

Not Included

Non Inclus

No Incluido

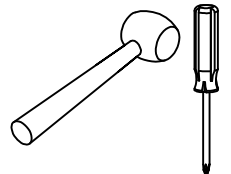

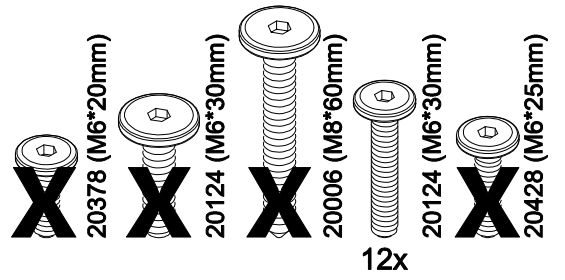
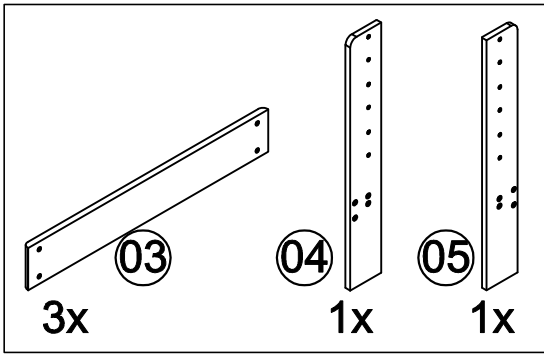

Manufacturer: Firstwood Company, Trang Bom District, Vietnam
 Importer: Maxwood Furniture Inc., Mt Pleasant, SC 29464, USA
 Item#: 190210-185, Prod. Date: , Made in Vietnam
 Section 103 Consumer Product Safety Improvement Act (CPSIA)
 CALIFORNIA 93120 PHASE 2 COMPLIANT FOR FORMALDEHYDE
 COMPLIANT WITH EPA 40 CFR 770 - TSCA VI REQUIREMENT FOR FORMALDEHYDE
This is a permanent label. Do not attempt to remove.

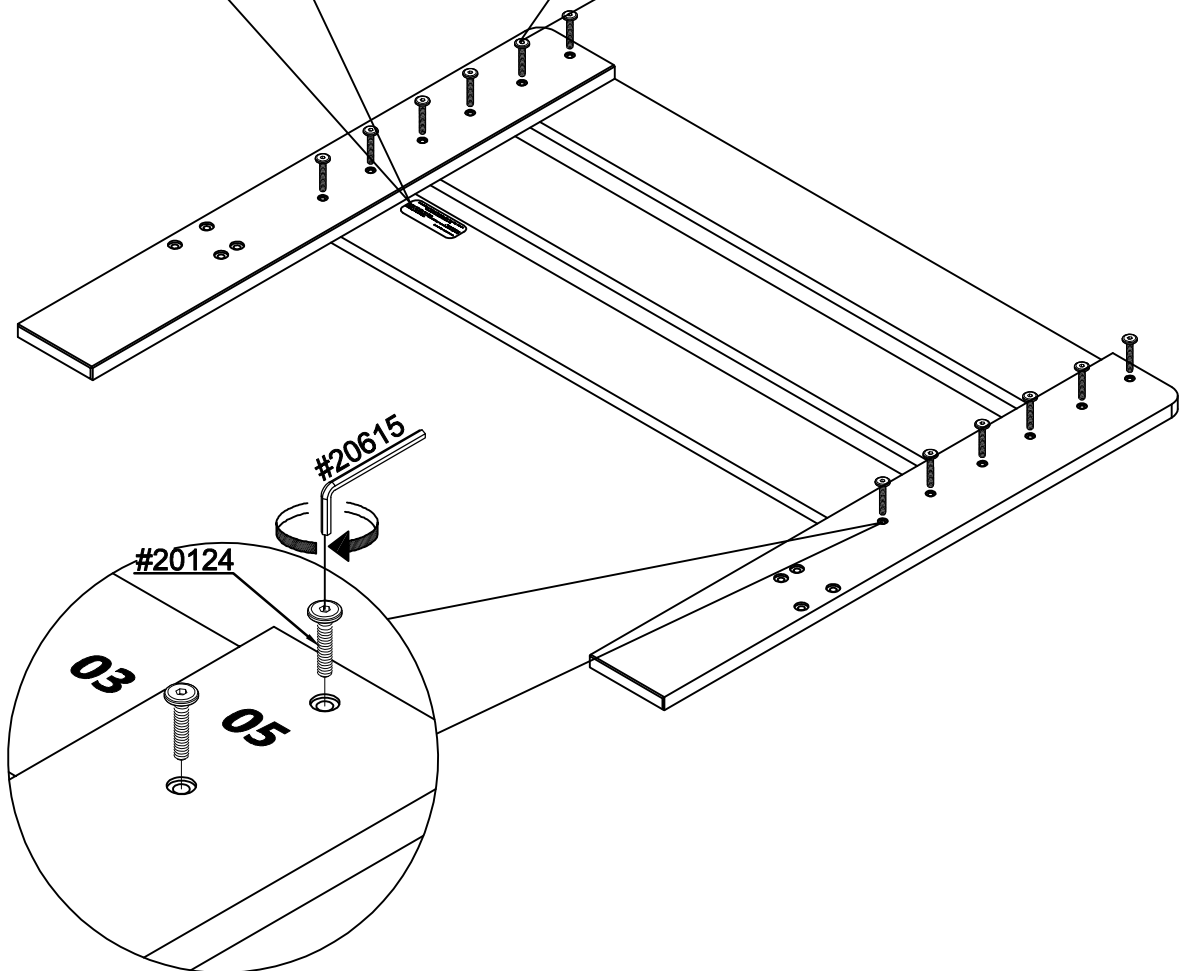
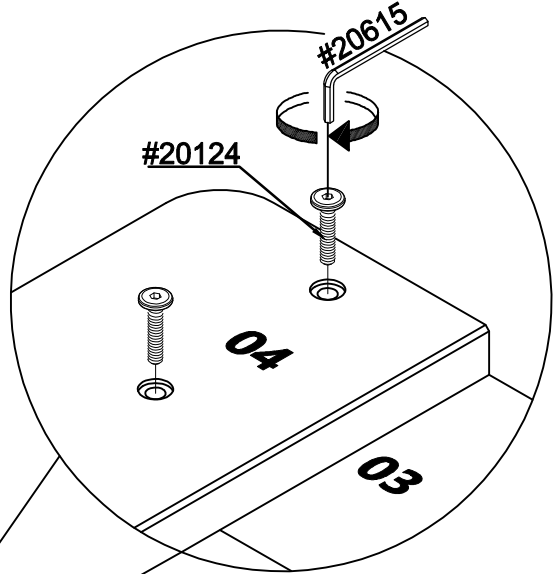

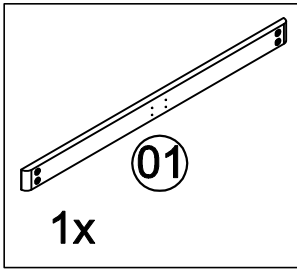

- ~~20428 (M6*25mm)~~
- ~~20378 (M6*20mm)~~
- ~~20124 (M6*30mm)~~
- ~~20006 (M8*60mm)~~
- 20792 (M8*30mm) 4x
- 20365 (8*13mm) 4x

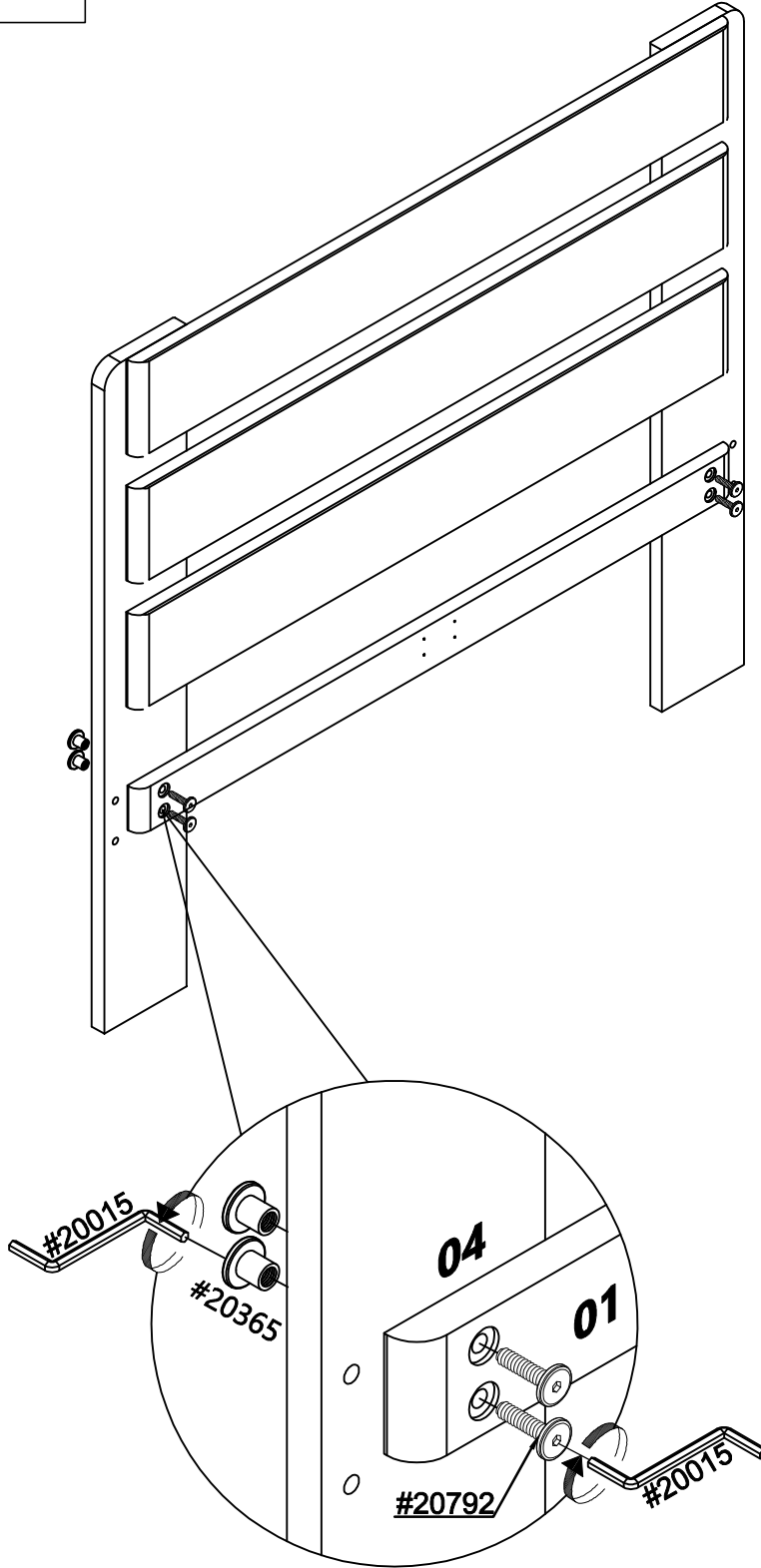

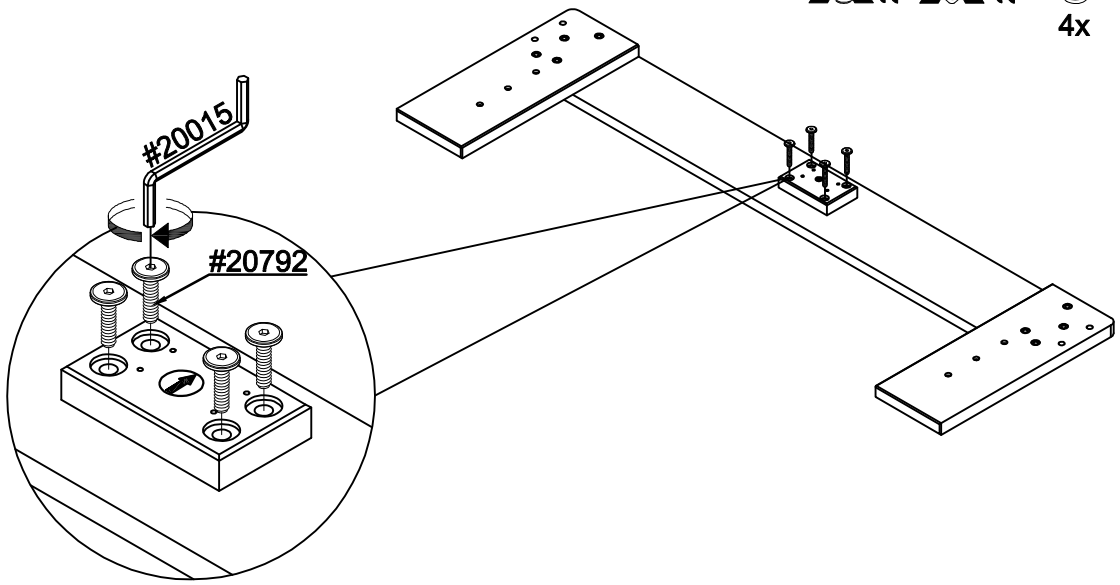
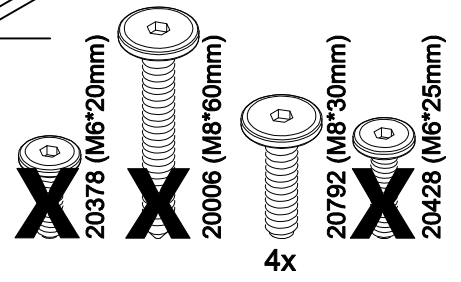
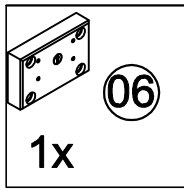
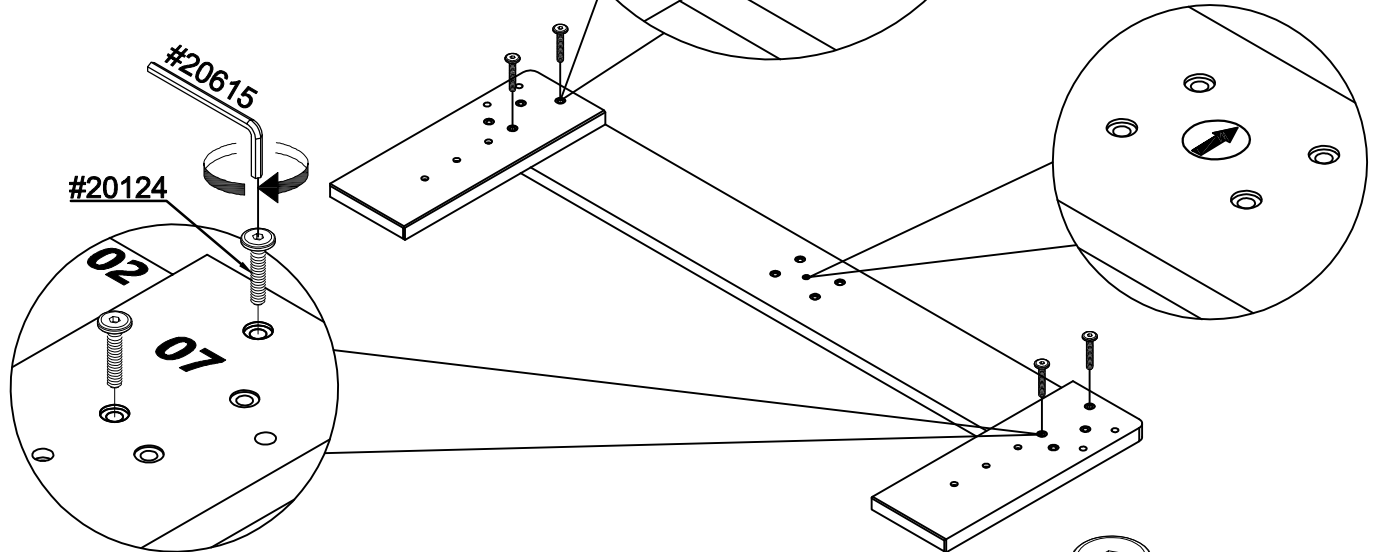
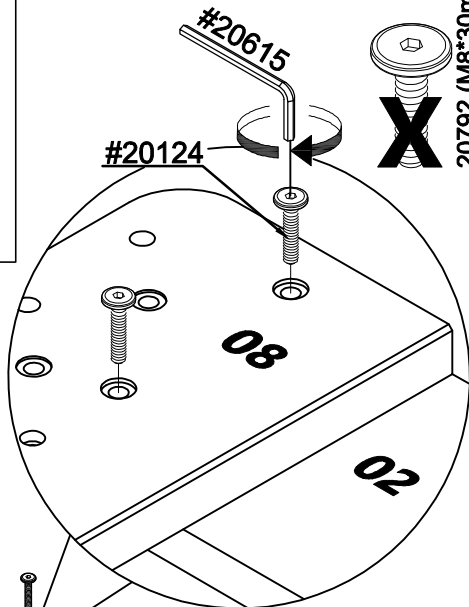
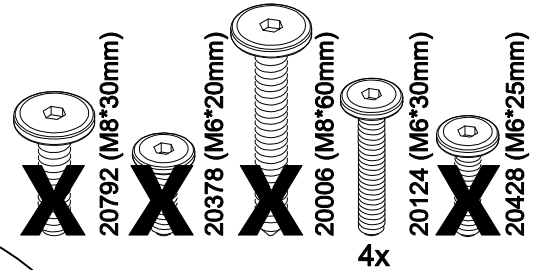
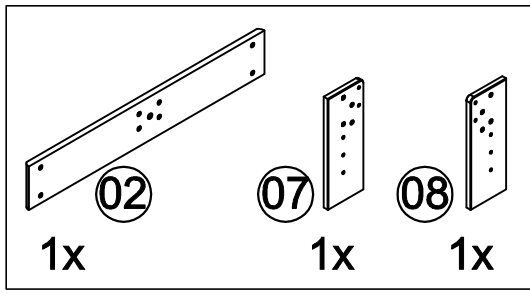

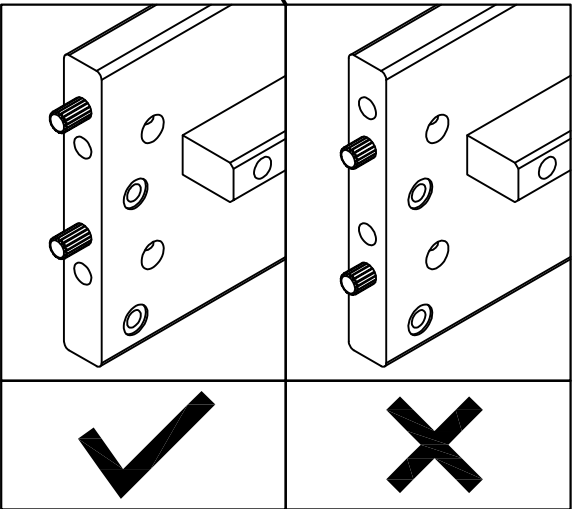
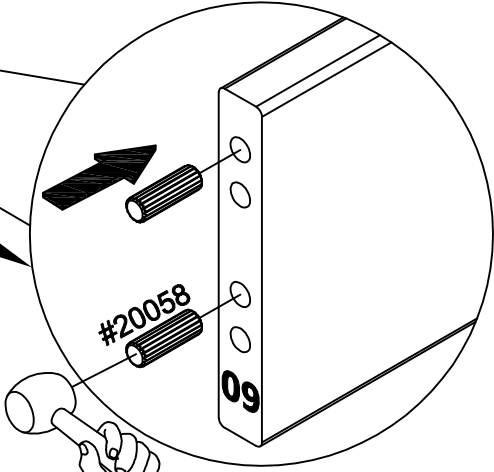
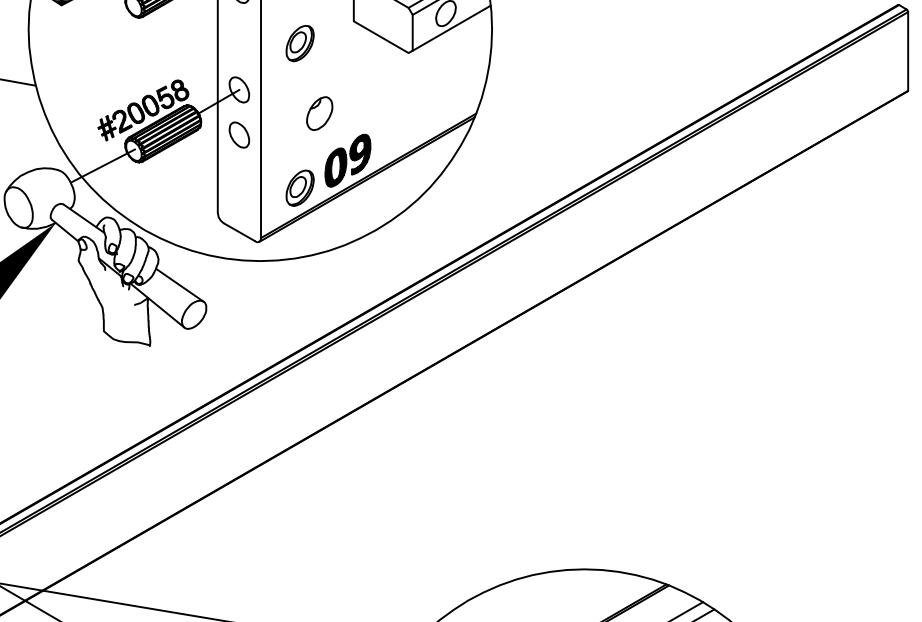
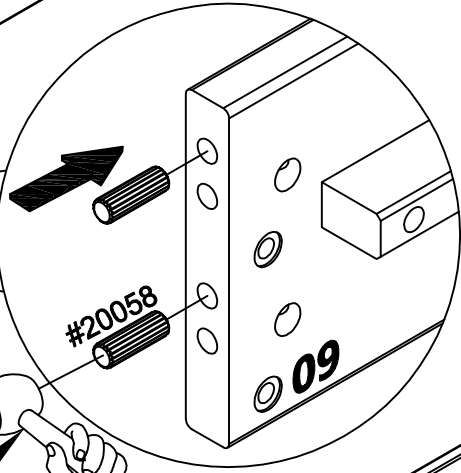
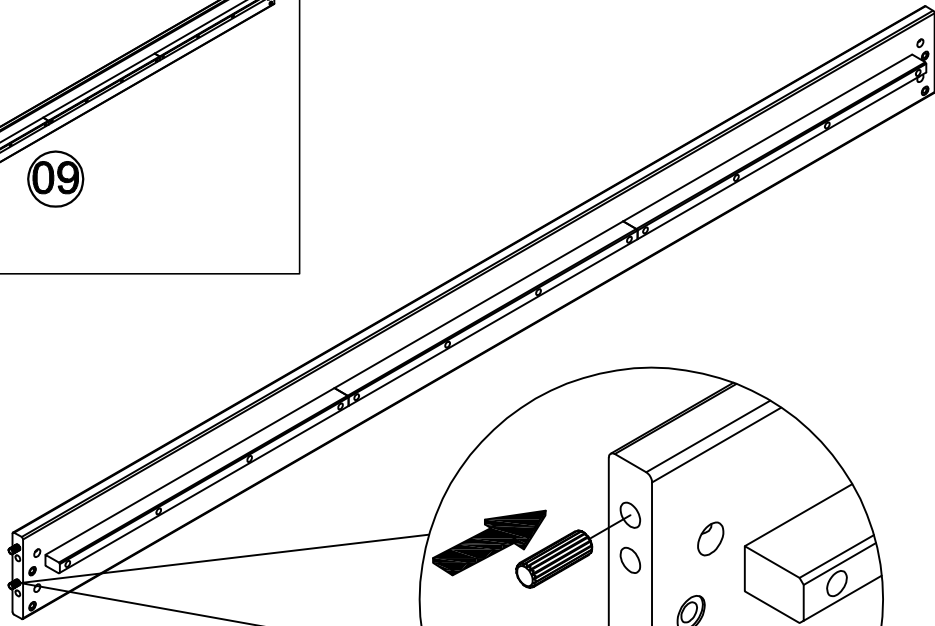
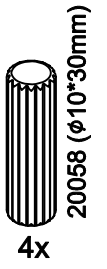
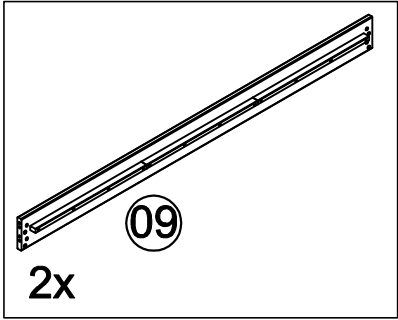

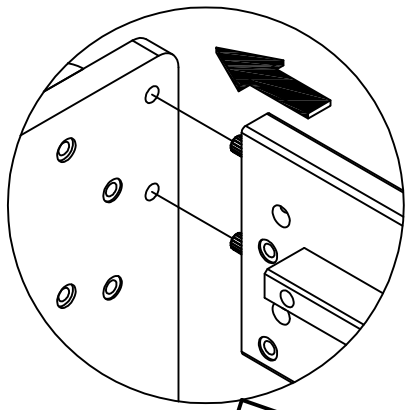

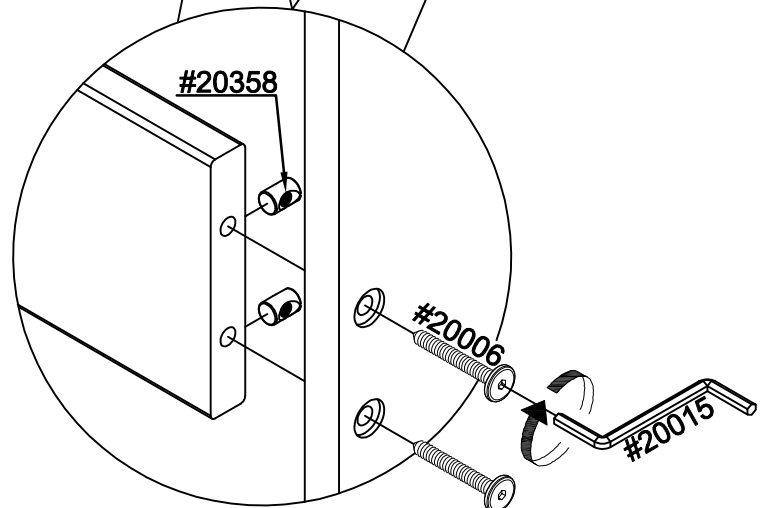
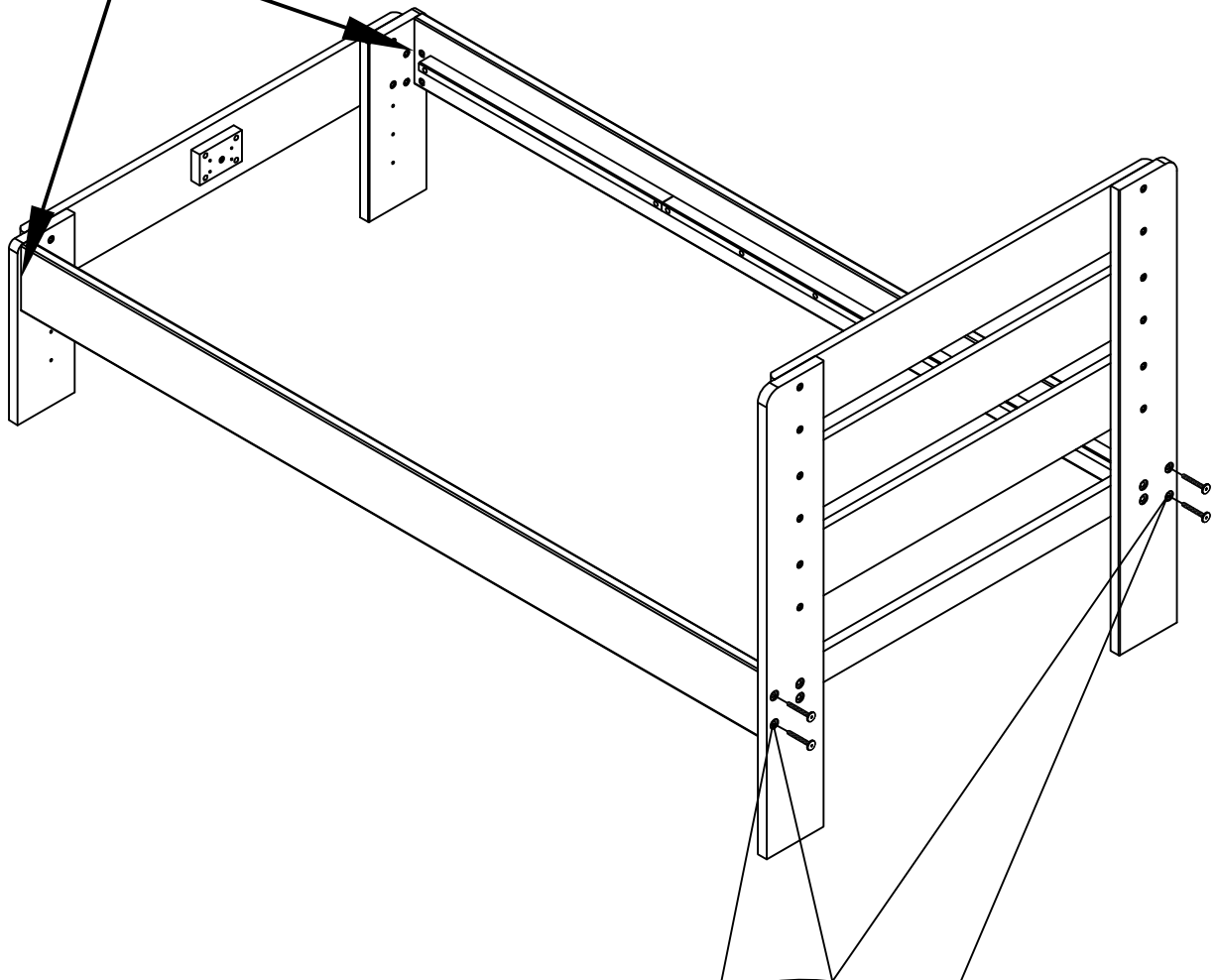

- X** 20378 (M6*20mm)
- X** 20428 (M6*25mm)
- 4x 20006 (M8*60mm)
- 4x 20358 (φM8*17mm)
- X** 20124 (M6*30mm)

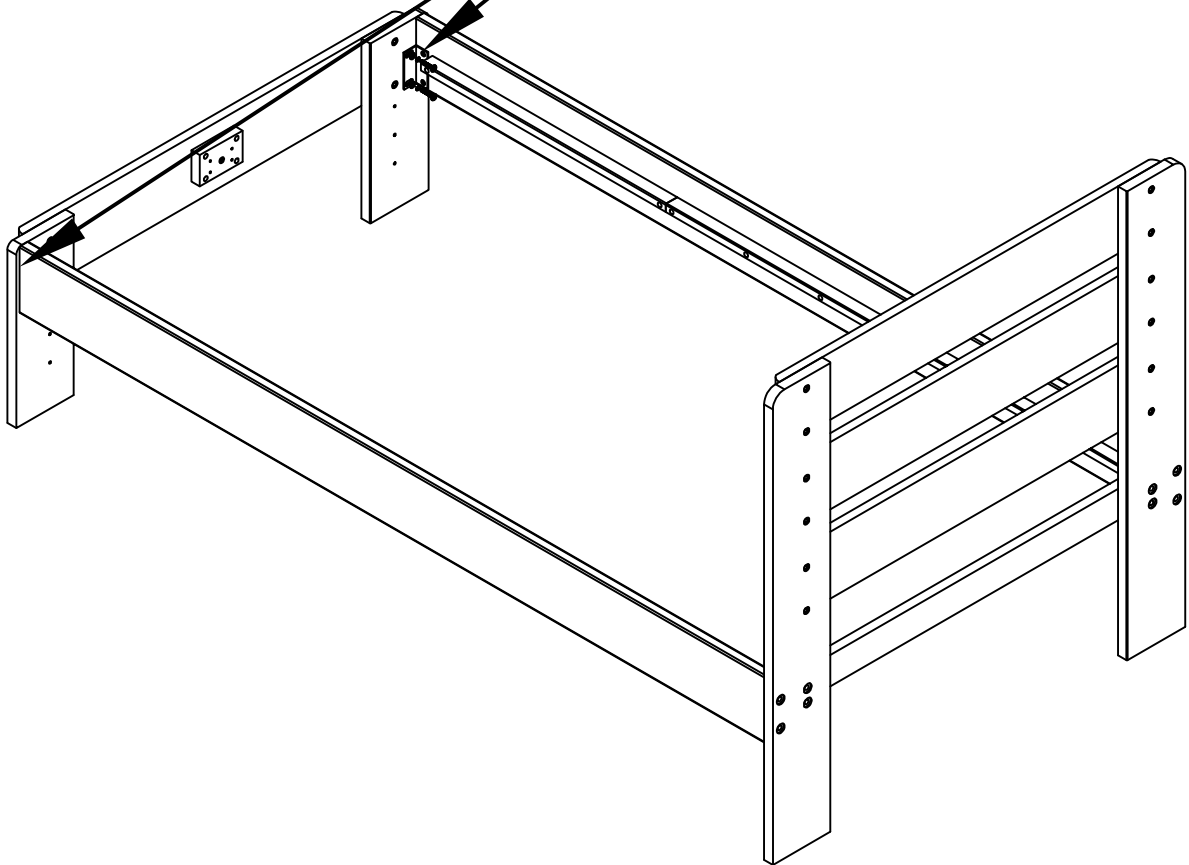
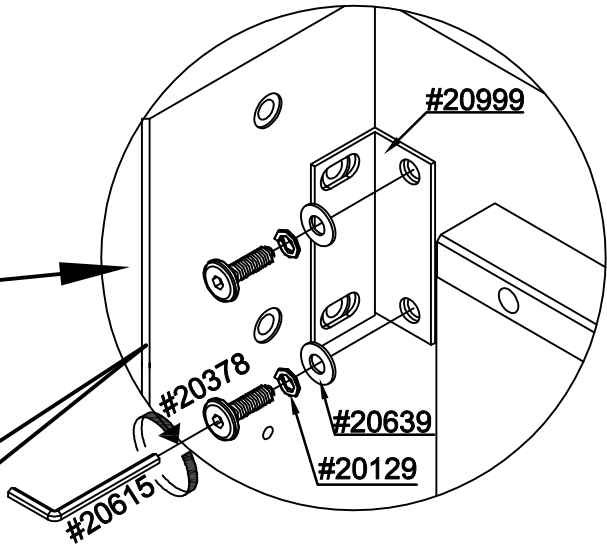
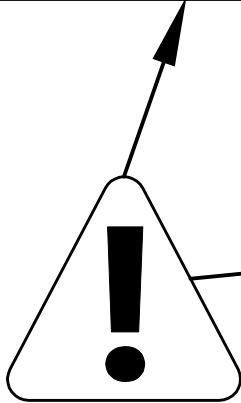
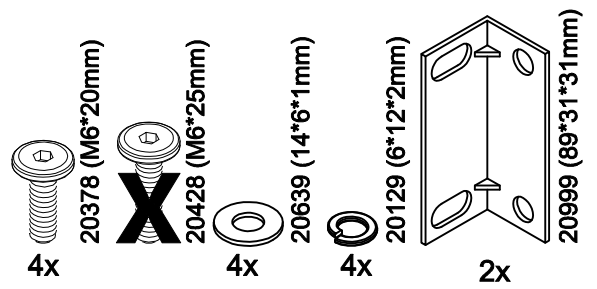
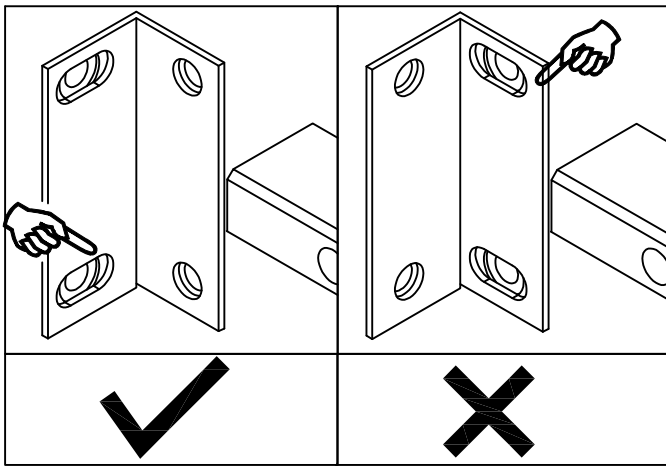

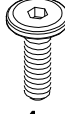

- 
20378 (M6*20mm)
- X**
20428 (M6*25mm)
- 
20639 (14*6*1mm)
- 
20129 (6*12*2mm)

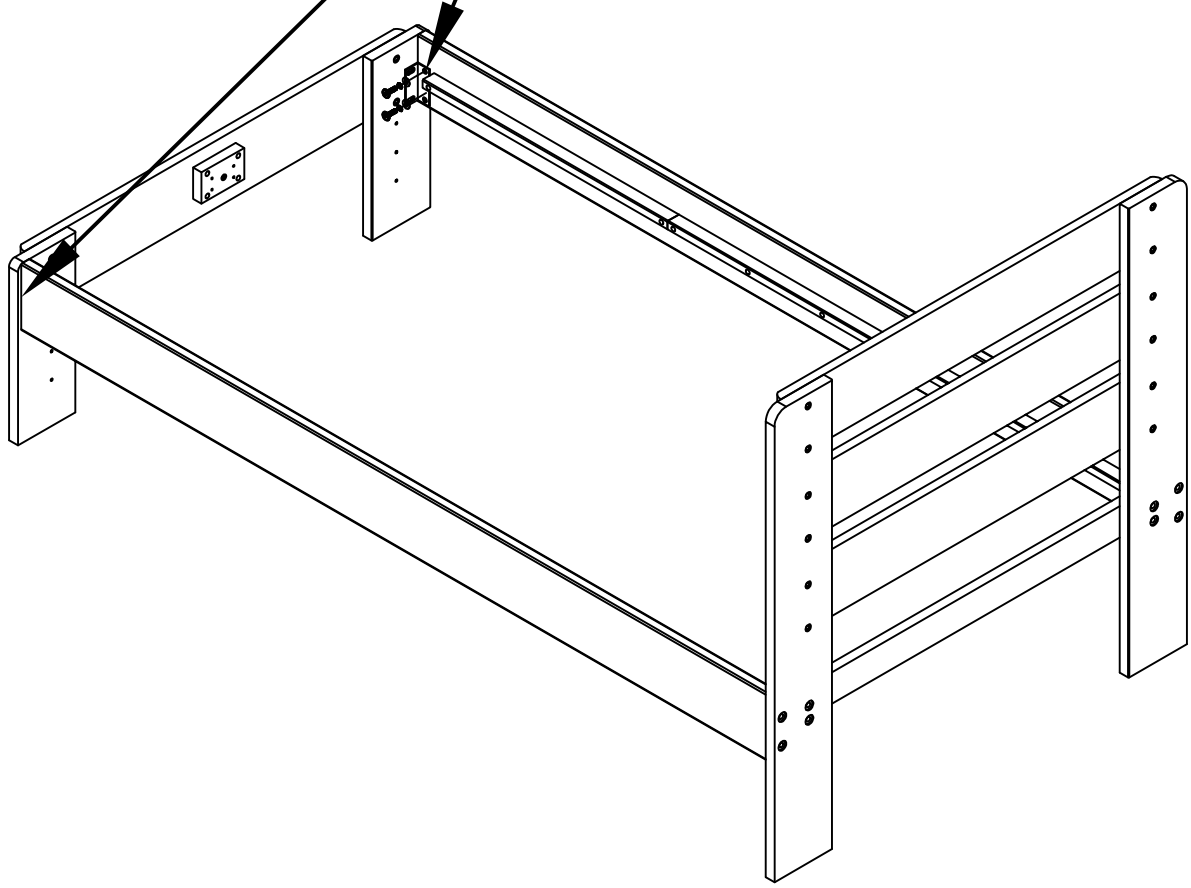
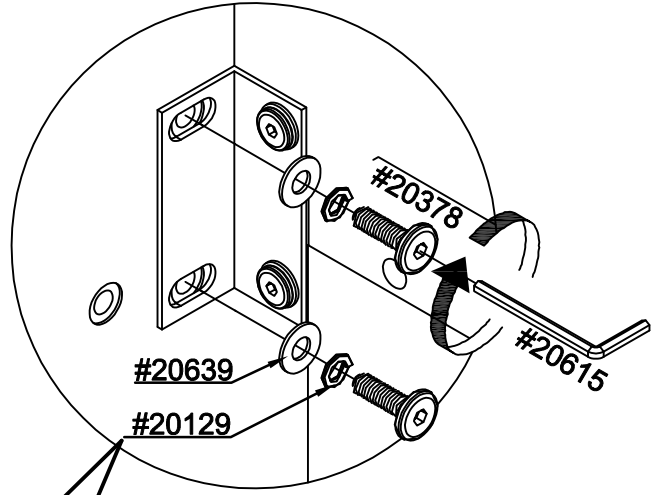

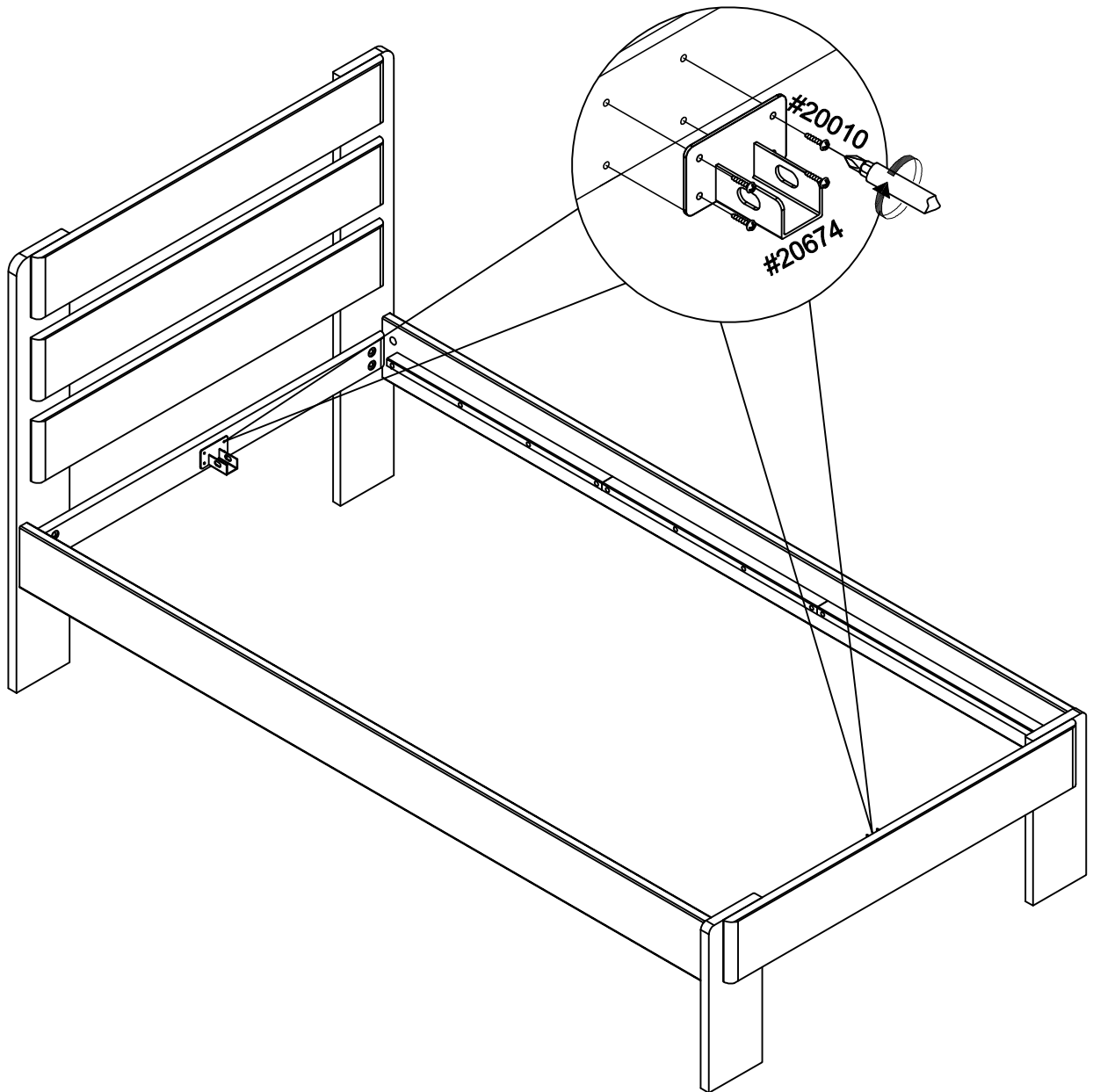
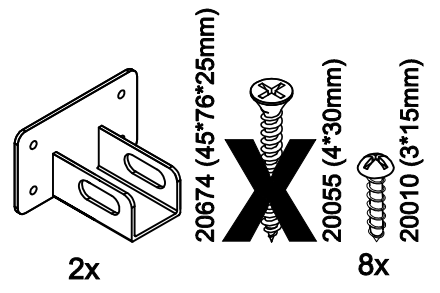

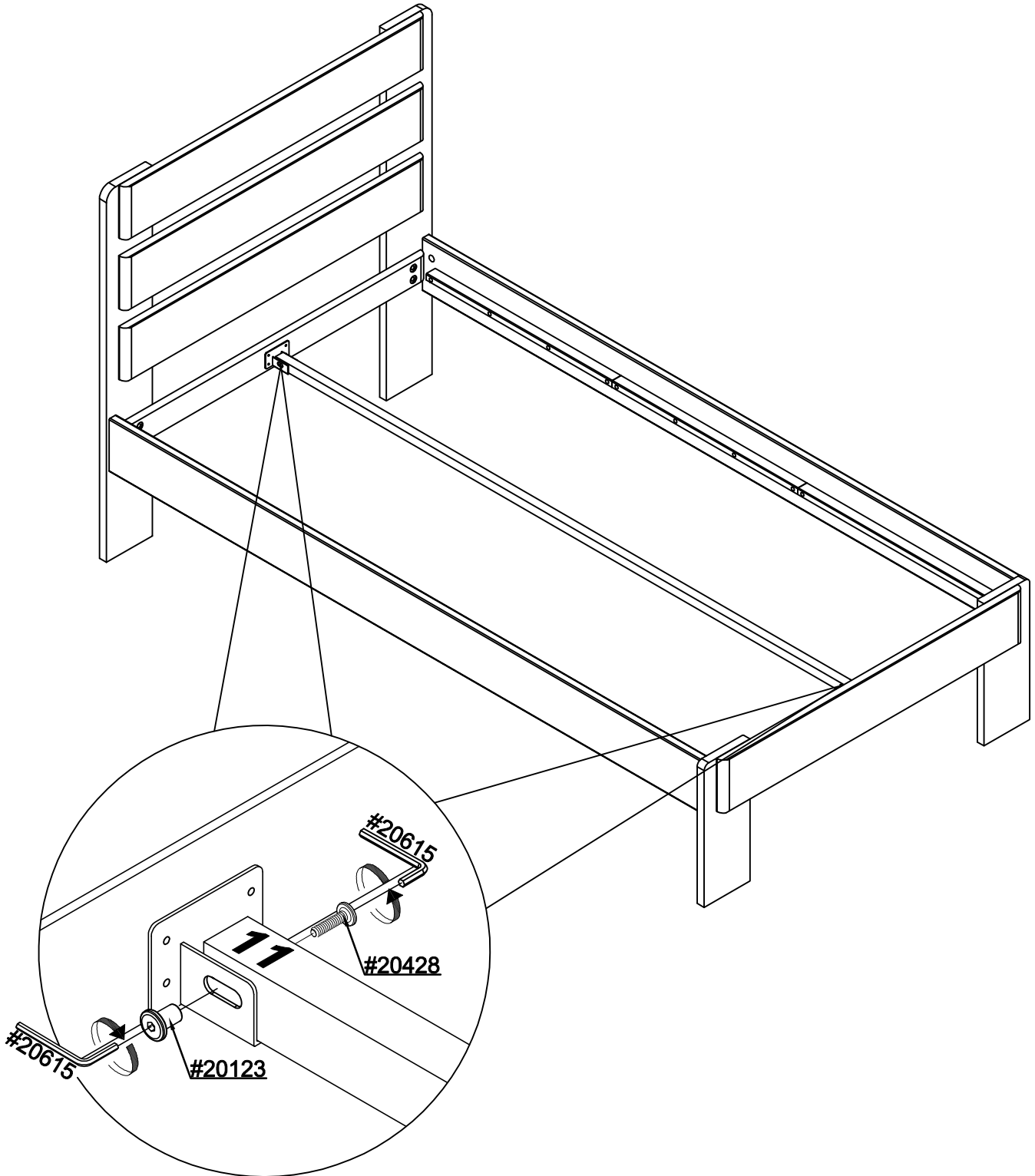
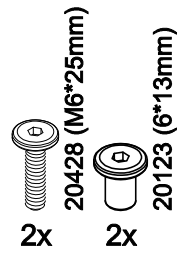
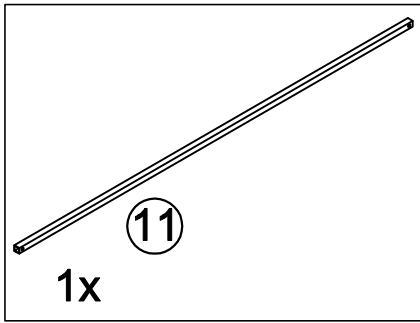

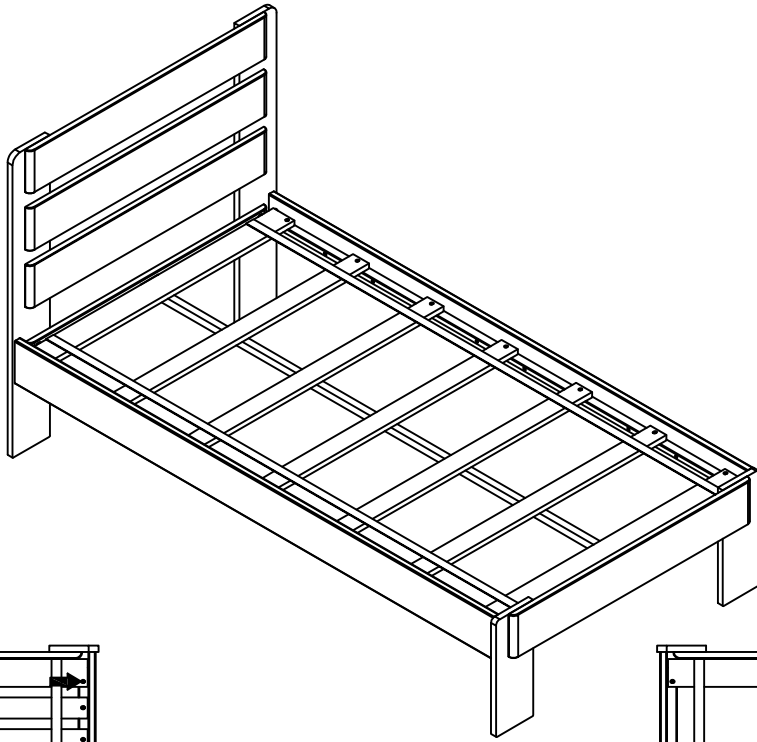

20055 (4*30mm)
2x

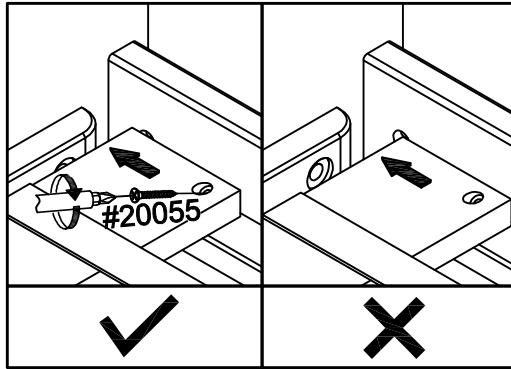
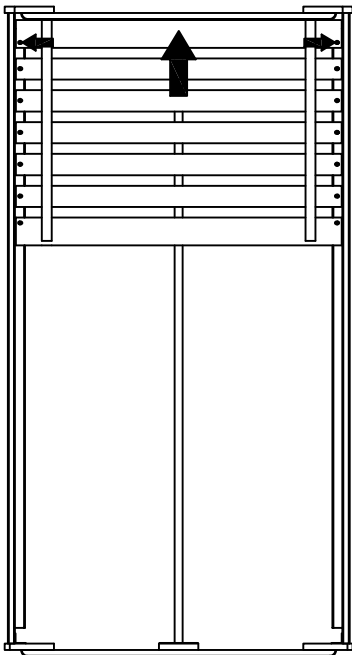

20055 (4*30mm)
2x

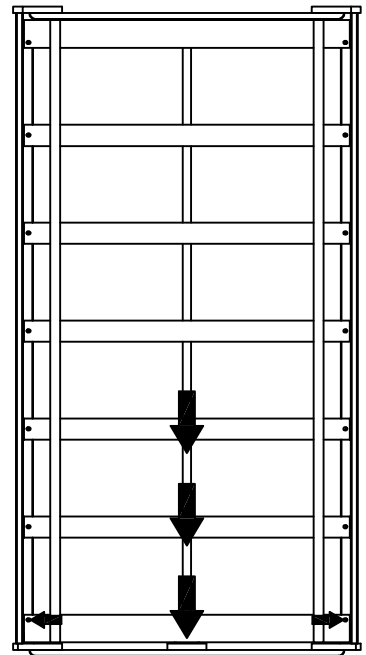

20055 (4*30mm)
2x

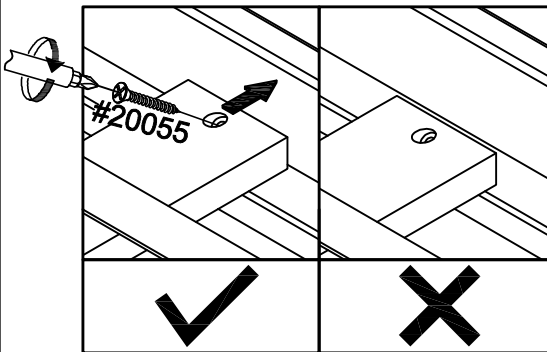
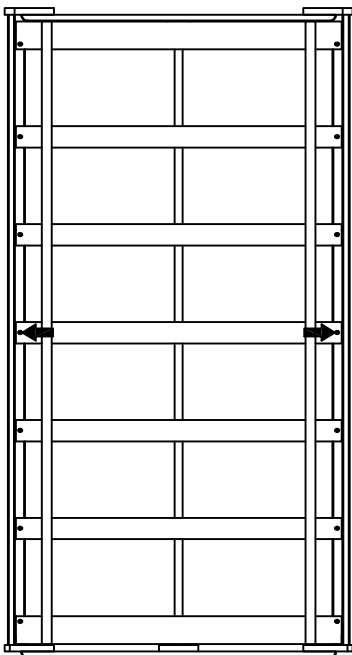

20055 (4*30mm)
8x

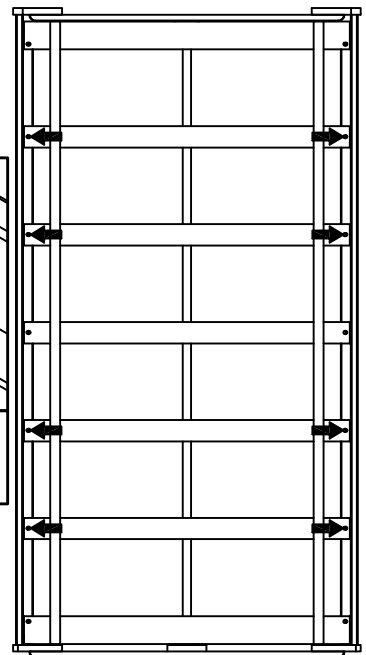

ENGLISH

Thank you for your purchase. We hope you and your kids will love it!
Please keep these assembly instructions for future reference.

Important:

Safety is our number one concern – please follow these simple safety tips:
Remember to check and tighten bolts/hardware once every few month, as these may loosen with use over time.

Make sure to anchor your large dressers to the wall with the free anti-tip kit provided.
Read and follow the safety instructions on the card attached to the front of your dresser.

Replacement Parts:

In case there is a problem with your product such as missing hardware, please contact your local dealer from whom you purchased the product, and they will be able to provide you with further information on how to obtain replacements.

FRANÇAIS

Merci pour votre achat de. Nous espérons que vous et vos enfants l'aimeront.
Veuillez conserver cette notice de montage pour une consultation ultérieure.

Important :

La sécurité est notre première préoccupation – veuillez suivre ces simples conseils de sécurité :
N'oubliez pas de vérifier et de serrer les boulons/la quincaillerie une fois tous les deux ou trois mois car ces derniers peuvent se desserrer avec le temps.

Assurez-vous d'ancrer vos grosses commodes au mur à l'aide de la trousse anti-basculement fournie.

Pièces de rechange :

En cas de problème avec votre produit comme de la quincaillerie manquante, veuillez contacter le distributeur local à qui vous avez acheté le produit, ce dernier pourra vous fournir plus d'information sur comment obtenir les pièces de rechange.

ESPAÑOL

Gracias por su compra de. Esperamos que usted y sus hijos les encantará.
Conserve estas instrucciones de montaje para futuras consultas.

Importante:

La seguridad es nuestra preocupación número uno - siga estos sencillos consejos de seguridad:
Recuerde revisar y apretar tornillos / herrajes una vez cada pocos meses, ya que estos pueden aflojarse con el uso a lo largo del tiempo.

Asegúrese de anclar sus aparadores grandes a la pared con el kit anti-tip gratuito proporcionado. Lea y siga las instrucciones de seguridad de la tarjeta colocada en la parte frontal de la cómoda.

Piezas de repuesto:

En caso de que se produzca un problema con el producto, como el hardware faltante, póngase en contacto con Su distribuidor local de quien adquirió el producto, y ellos podrán proporcionarle más información sobre cómo obtener los reemplazos.