

ASSEMBLY INSTRUCTIONS

ASSEMBLY TIPS:

1. Remove hardware from box and sort by size.
2. Please check to see that all hardware and parts are present prior to start of assembly.
3. Please follow attached instructions in the same sequence as numbered to assure fast & easy assembly.







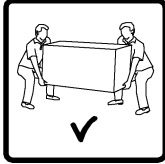





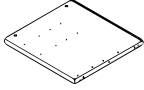

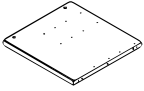

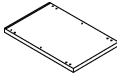
Warning!

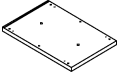
1. Don't attempt to repair or modify parts that are broken or defective. Please contact the store immediately.
2. This product is for home use only and not intended for commercial establishment.

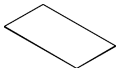

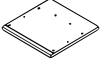

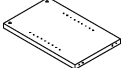

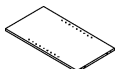



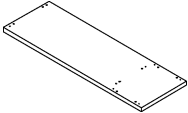
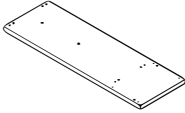
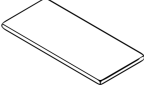
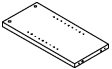

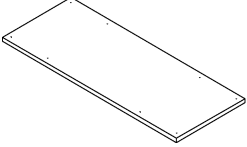
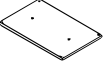



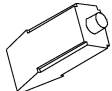
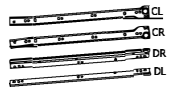
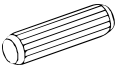

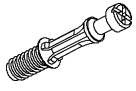
ASSEMBLY TIME	80 MINUTES
----------------------	-------------------

PARTS IDENTIFICATION:

(A) LARGE LEFT SIDE PANEL		1 PC	(I) LARGE RIGHT DRAWER SIDE PANEL		1 PC
(B) LARGE RIGHT SIDE PANEL		1 PC	(J) SMALL DRAWER BOTTOM PANEL		2 PCS
(C) SMALL BOTTOM PANEL		1 PC	(K) SMALL DRAWER FRONT PANEL		2 PCS
(D) TOP DRAWER PANEL		1 PC	(L) SMALL DRAWER BACK PANEL		2 PCS
(E) BACK PANEL		1 PC	(M) SMALL LEFT DRAWER SIDE PANEL		2 PCS
(F) LARGE DRAWER FRONT PANEL		1 PC	(N) SMALL RIGHT DRAWER SIDE PANEL		2 PCS
(G) LARGE DRAWER BACK PANEL		1 PC	(O) SMALL LEFT SIDE PANEL		1 PC
(H) LARGE LEFT DRAWER SIDE PANEL		1 PC	(P) SMALL RIGHT SIDE PANEL		1 PC

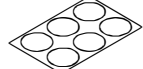
ASSEMBLY INSTRUCTIONS

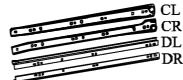
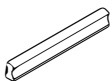
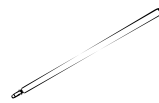
<p>(Q) LARGE BOTTOM PANEL  1 PC</p> <p>(R) MIDDLE TOP PANEL  1 PC</p> <p>(S) LARGE ADJUSTABLE PANEL  1 PC</p> <p>(T) DIVIDER PANEL  2 PCS</p>	<p>(U) SMALL ADJUSTABLE PANEL  2 PCS</p> <p>(V) LARGE TOP PANEL  1 PC</p> <p>(A1) LARGE TOP PANEL PARTITION BOARDS  2 PCS</p> <p>(B1) LARGE DRAWER BOTTOM PANEL  1 PC</p>
---	---

Z							
HARDWARE IDENTIFICATION							
NO	DESCRIPTION	FIGURE	Q'TY	NO	DESCRIPTION	FIGURE	Q'TY
1	GLUE 40g		1 PC	10	SAMLL RAIL (L = 400mm WHT)		2 SET
2	WOODEN DOWEL ø8x30mm		34 PCS	11	SHORT SCREW (ø3x12mm SR)		42 PCS
3	CAM BOLT (ø7x35.5mm SR)		18 PCS	12	FOOT 50x50x18mm		9 PCS
4	CAM LOCK (ø15x12mm SR)		18 PCS	13	SCREW FOR FOOT (ø5x23mm BLK)		18 PCS
5	LONG SCREW (ø4.3x35mm SR)		20 PCS	14	SHORT BOLT (M6x42mm SR)		4 PCS
6	LONG BOLT ø9.5x55mm (FOR BOTTOM PANEL SR)		14 PCS	15	STICKER ø20mm		3 PCS
7	PIN (ø4.9x8mm SR)		12 PCS	16	LARGE RAIL (L = 450mm WHT)		1 SET
8	HANDLE L=120mm		3 PCS	17	IRON BAR (ø9.5x268mm SR)		2 PCS
9	HANDLE BOLT (ø4x28mm SR)		6 PCS				

Z8,Z9,Z10,Z12,Z16,Z17 not included in blister packaging.

ASSEMBLY INSTRUCTIONS

STEP 1 :

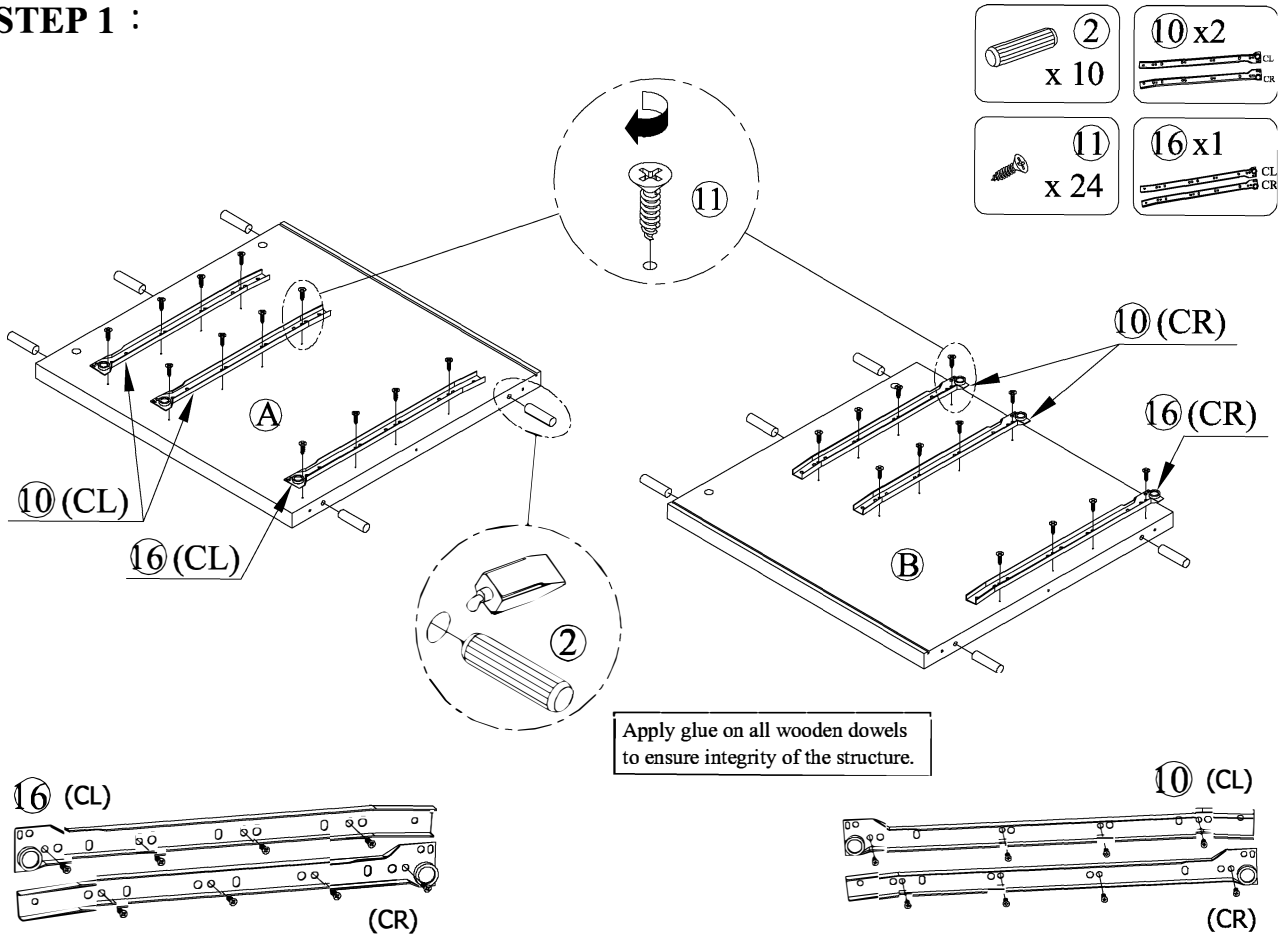

STEP 2 :

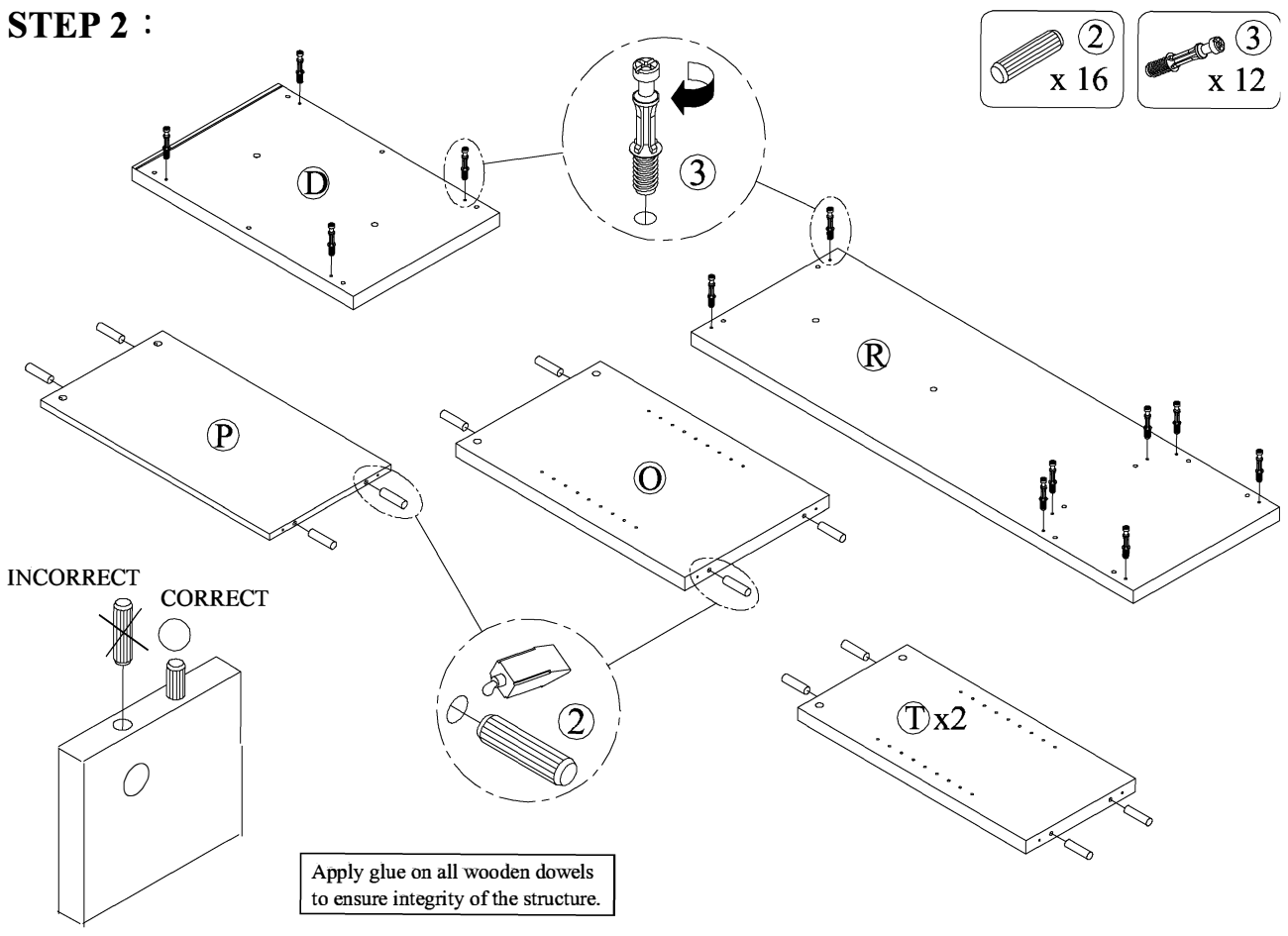

ASSEMBLY INSTRUCTIONS

STEP 3 :

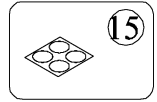
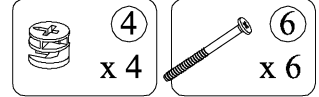
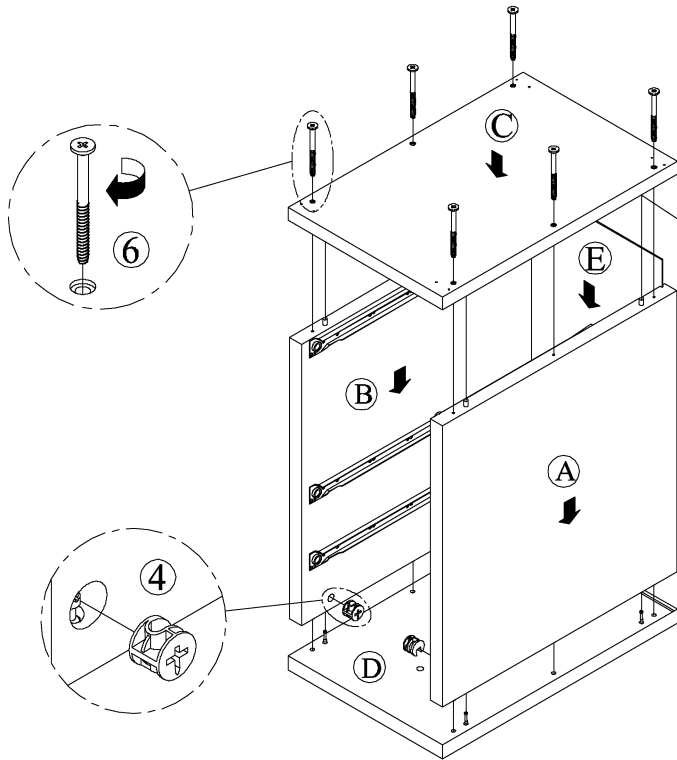

Apply glue on all wooden dowels to ensure integrity of the structure.

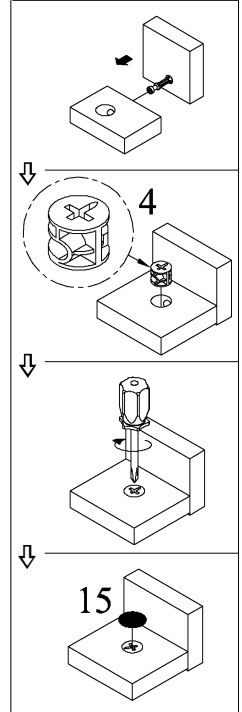

STEP 4 :

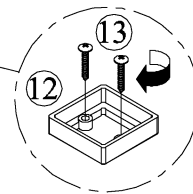
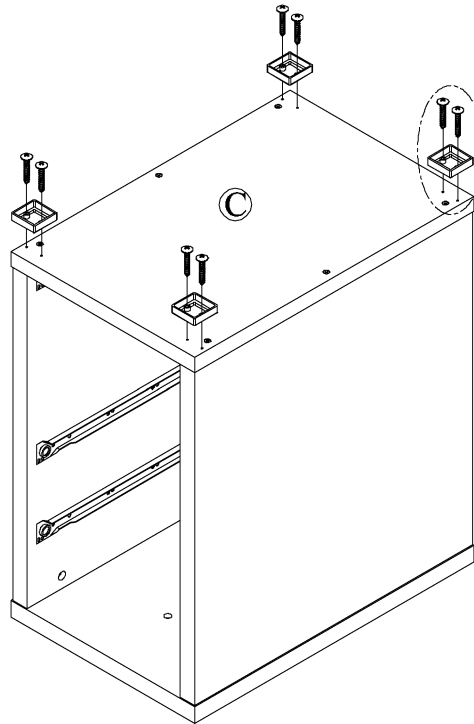

ASSEMBLY INSTRUCTIONS

STEP 5 :

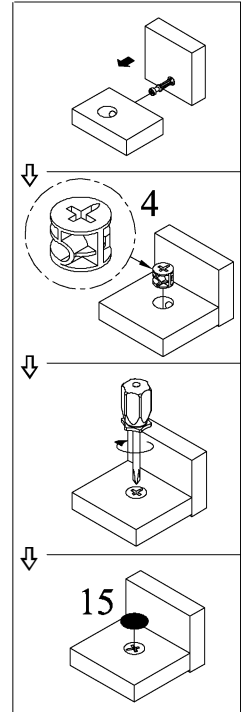
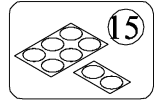
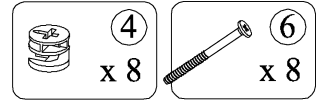
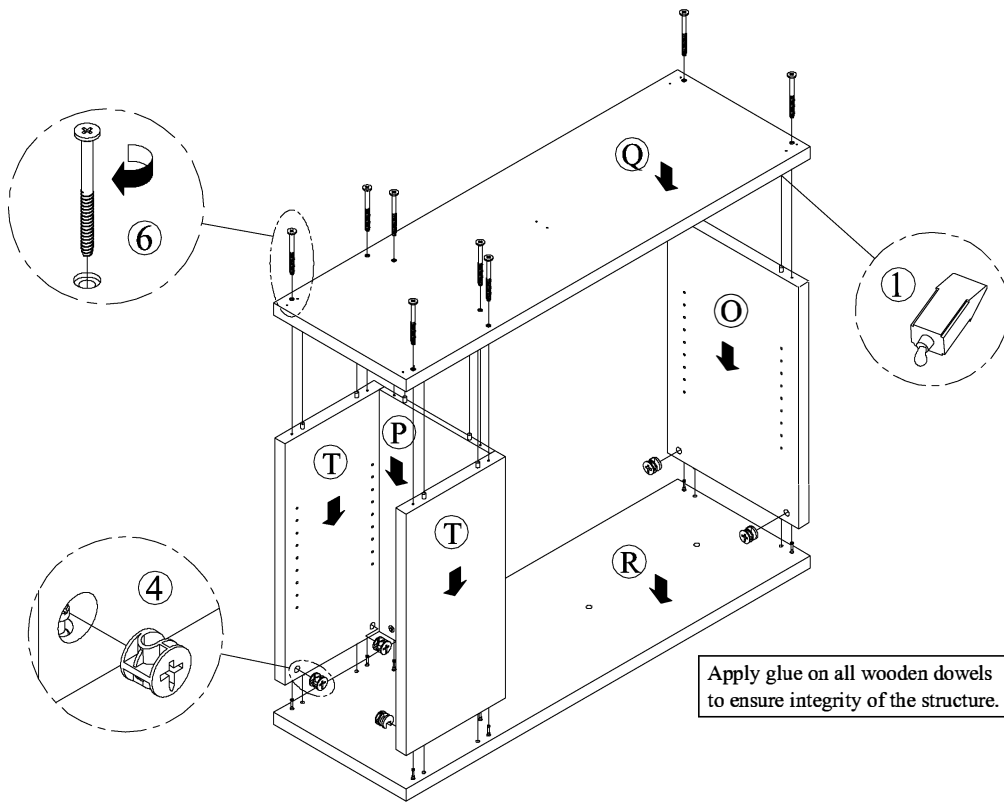

Apply glue on all wooden dowels to ensure integrity of the structure.

STEP 6 :

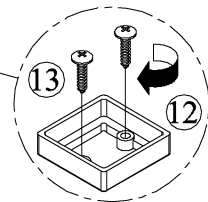
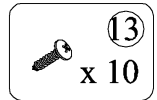
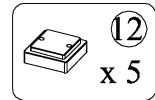
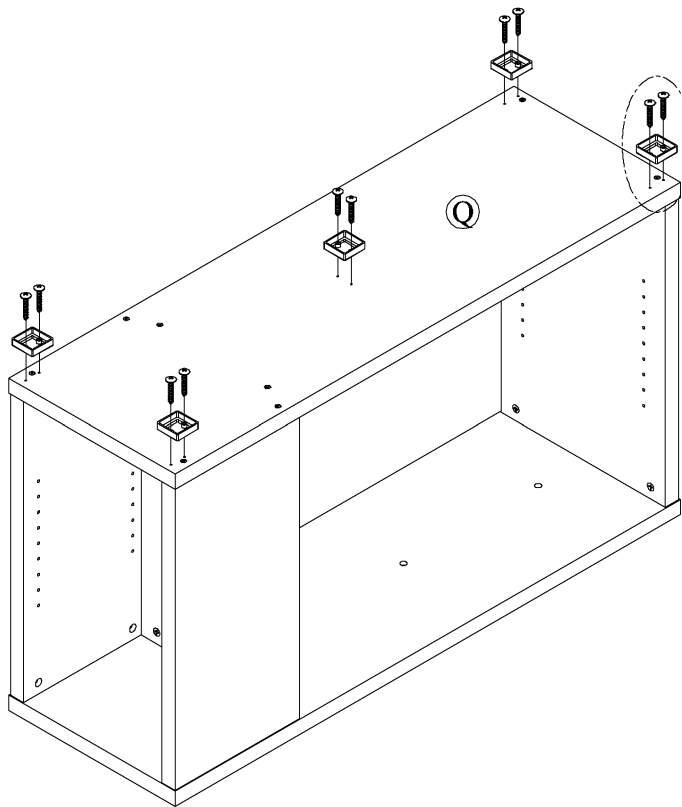

ASSEMBLY INSTRUCTIONS

STEP 7 :

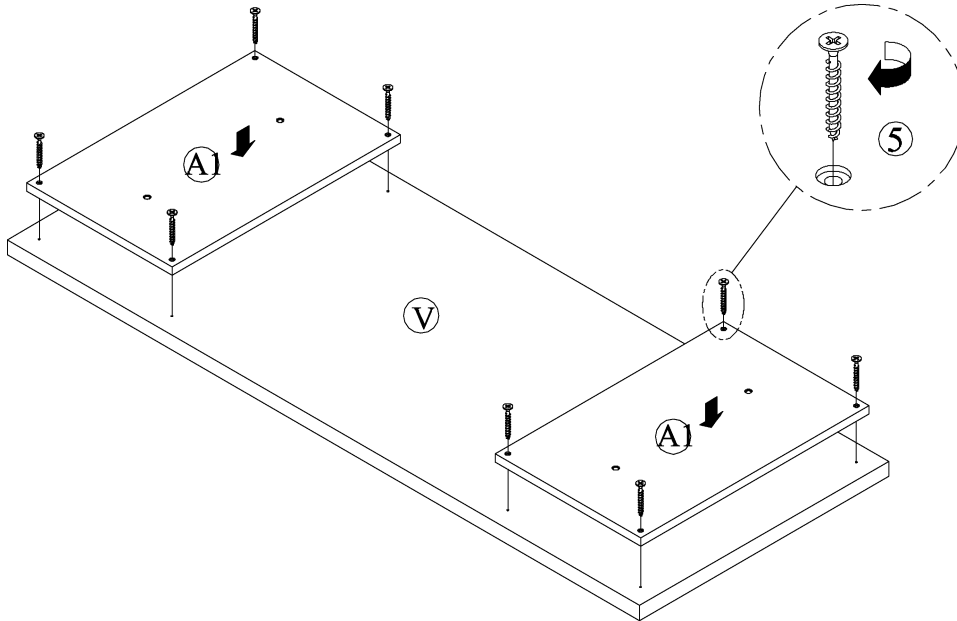
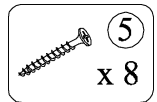

STEP 8 :

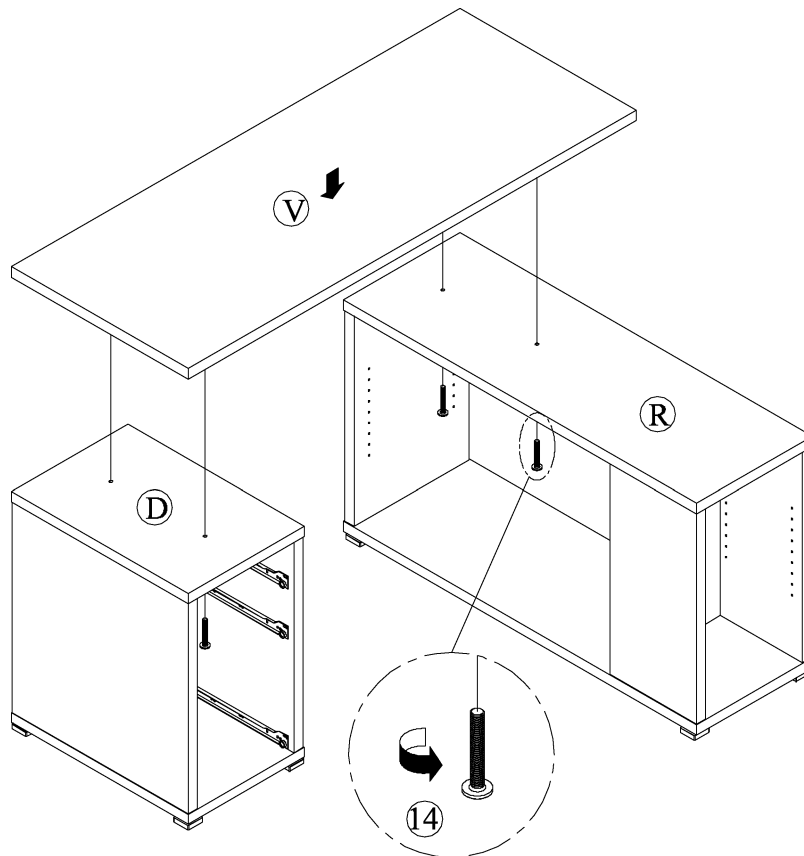
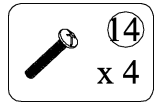

STEP 9 :

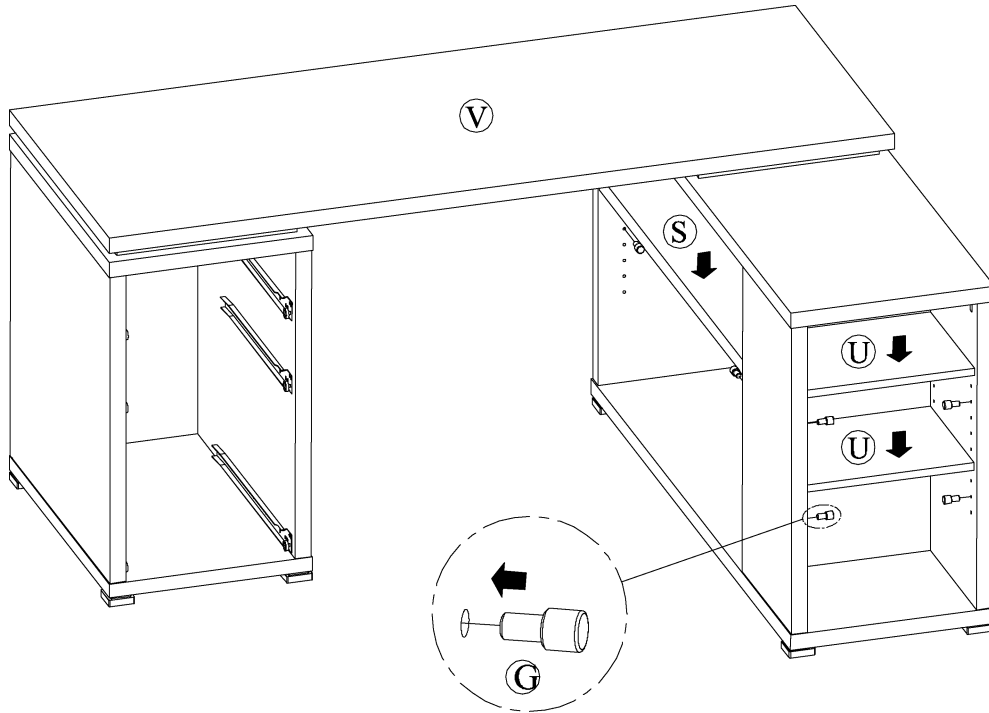
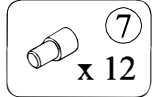

STEP 10 :

Apply glue on all wooden dowels to ensure integrity of the structure.

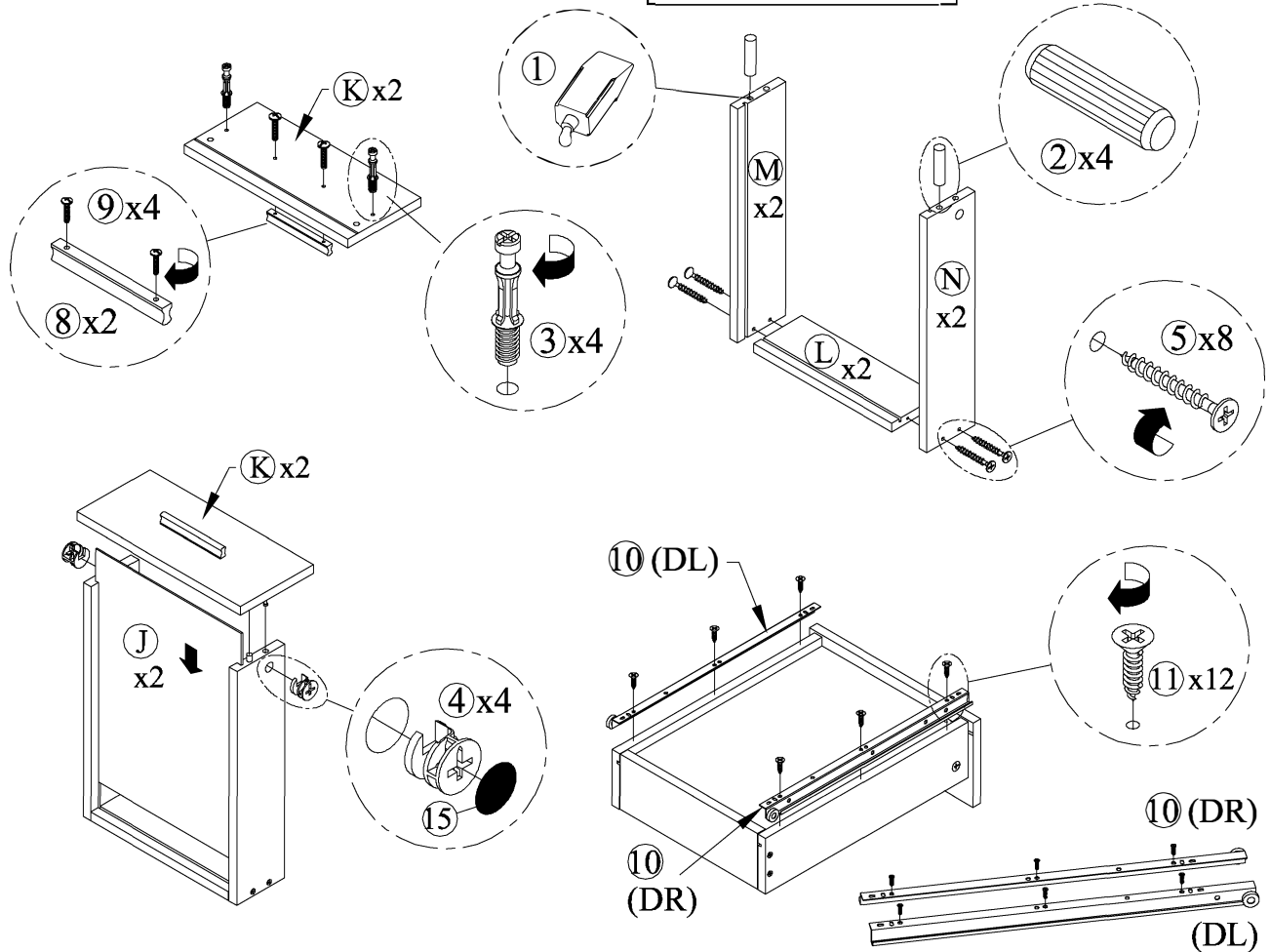

ASSEMBLY INSTRUCTIONS

STEP 11 :

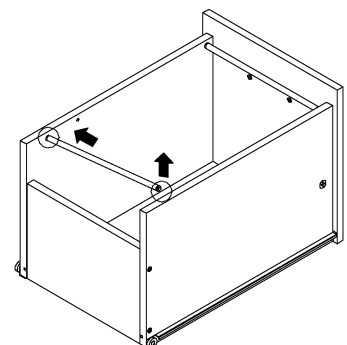
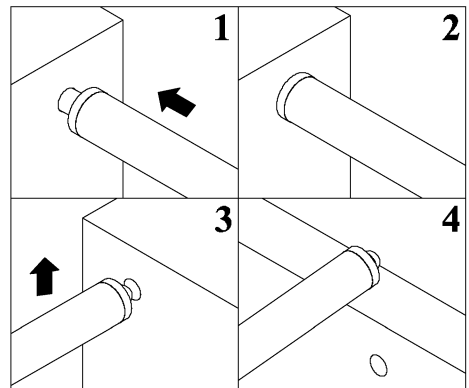
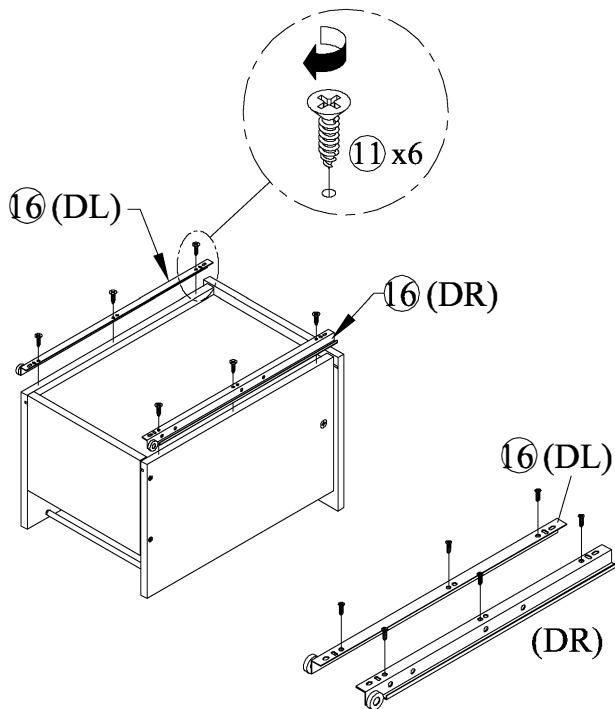
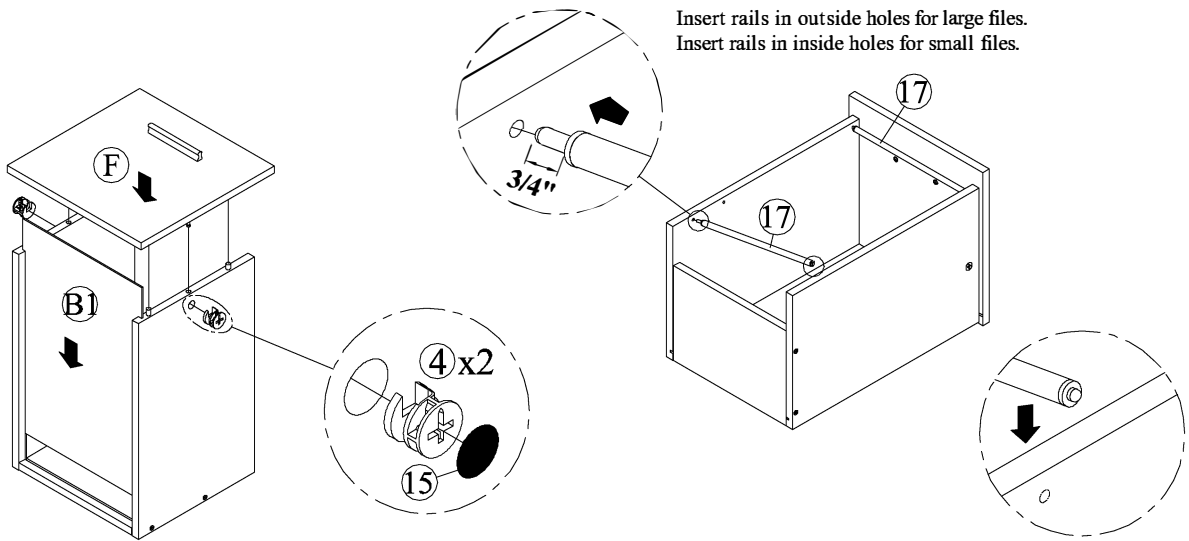
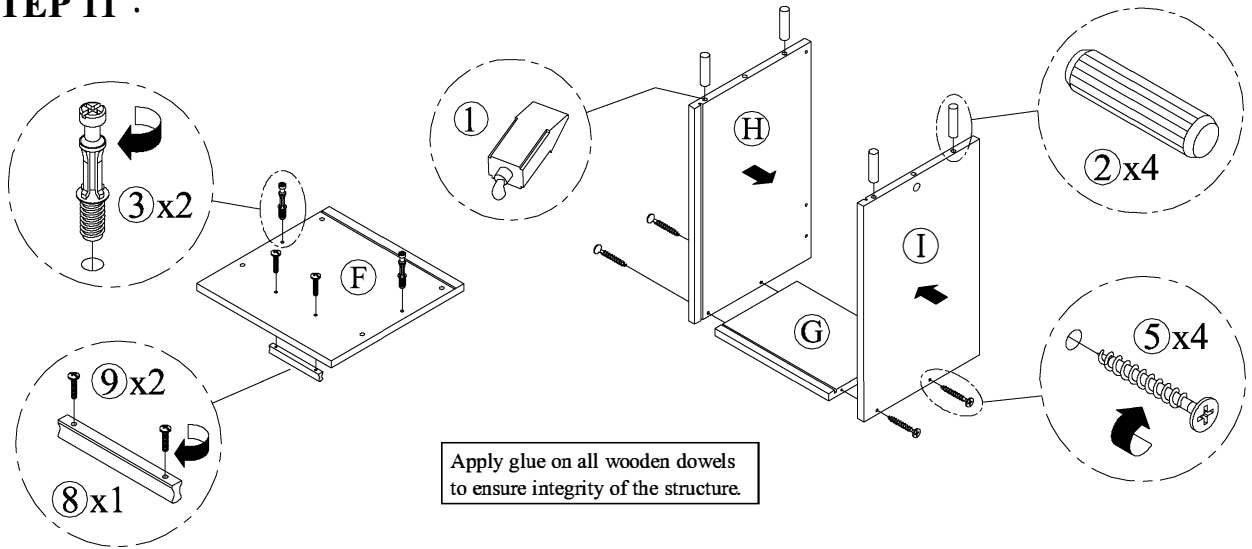

STEP 12 :

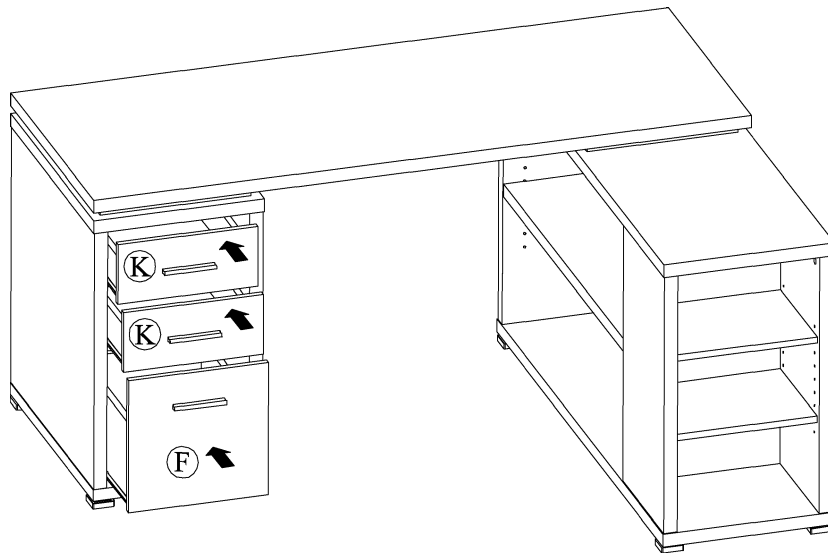

STEP 13 :
COMPLETE

