

ARDEN TALL GLASS DISPLAY CABINET

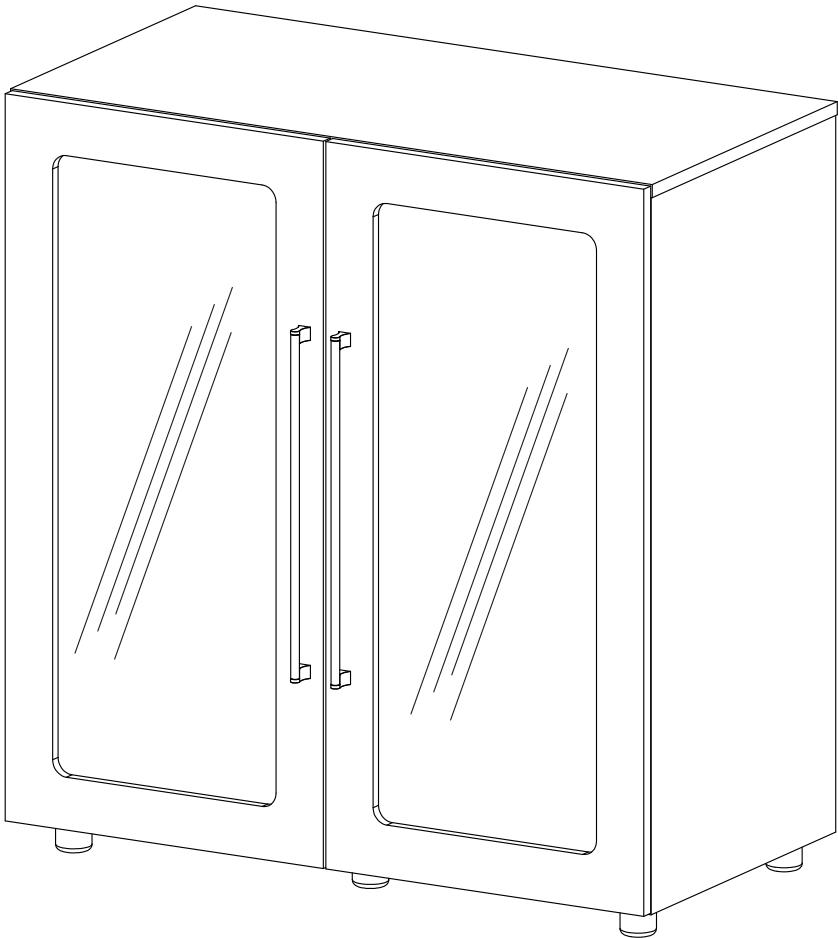

Part	Description	Dimensions (in)	Qty.
01	Bottom panel	30,6 x 15,9	01
02	Left panel	32 x 15,9	01
03	Top panel	32 x 15,9	01
04	Right panel	32 x 15,9	01
05	Shelf	30,6 x 13,9	01
06	Back panel	31 x 15,9	01
07	Foot	1,5 x 1,5	05
08	Door	32,5 x 15,8	02
09	Glass	28,6 x 12	02
10	Top rail	30,6 x 2,3	01
11	Shelf rail	30,6 x 2,3	01

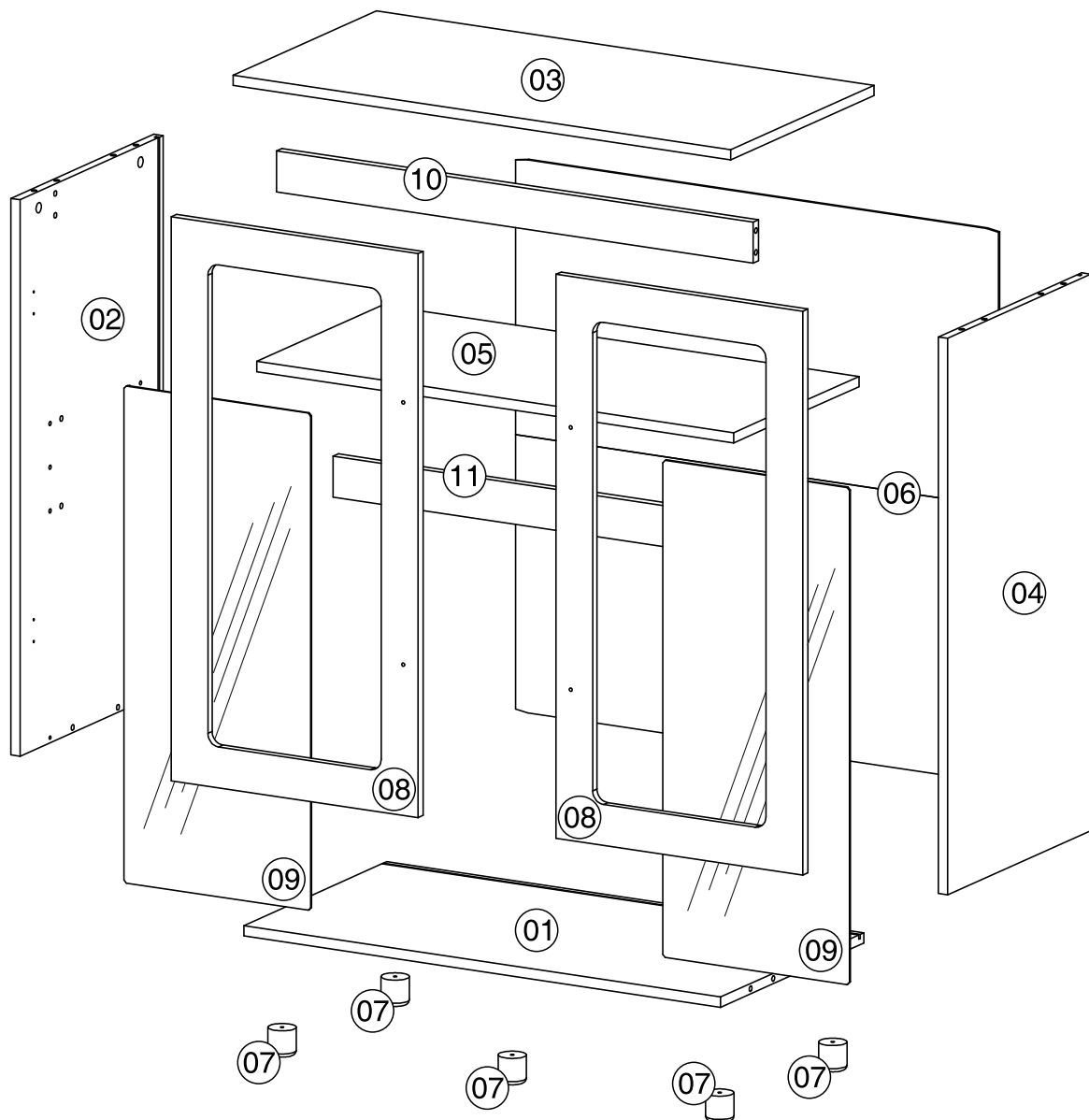

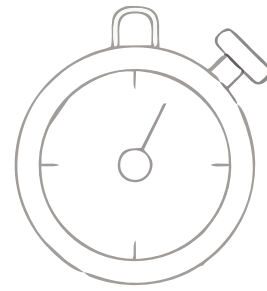
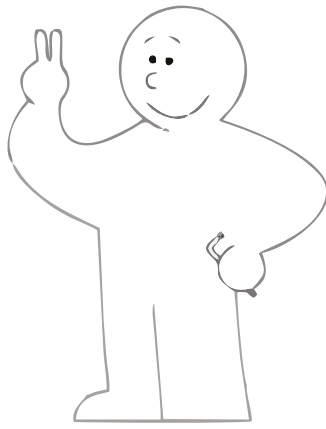
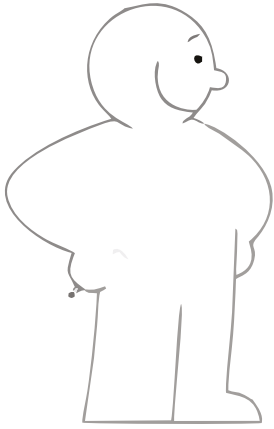

40 Min

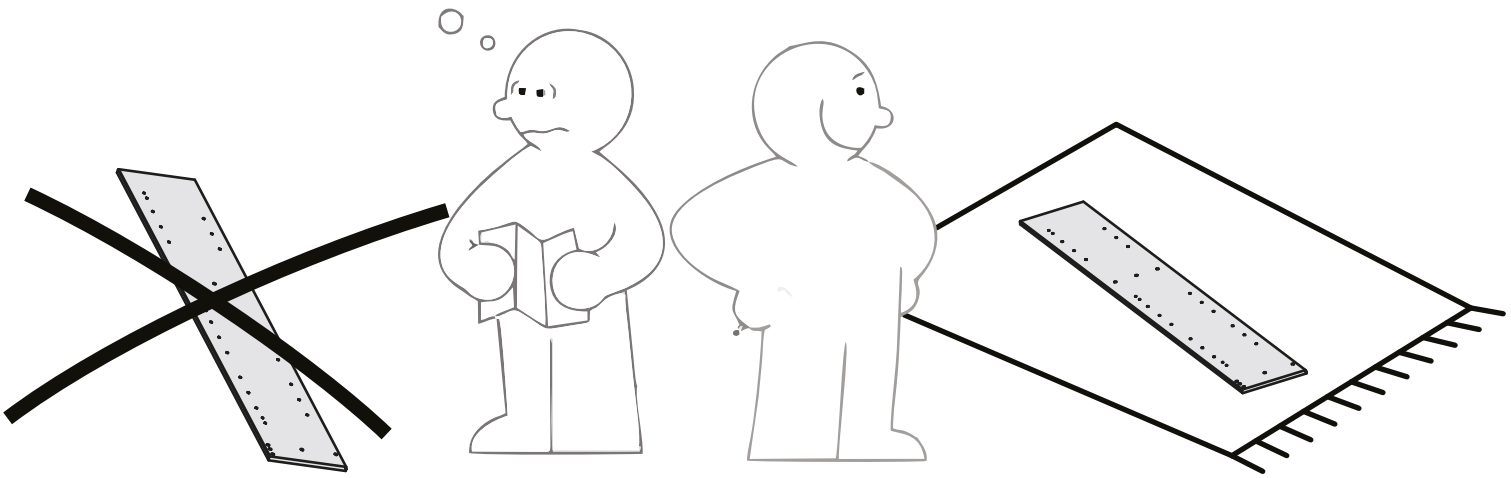

Tools required

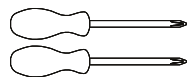
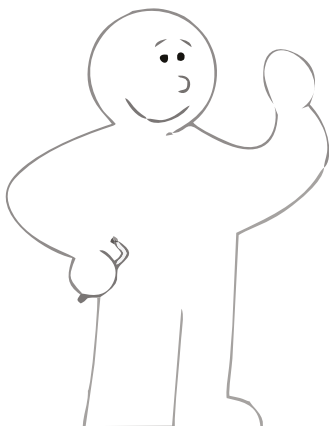

Phillips screwdriver
(medium & large)

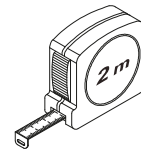



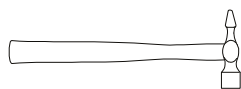



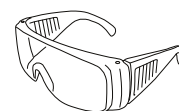



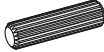
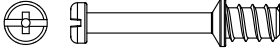
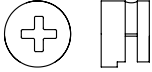

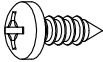
Ruler/tape
measure

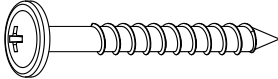

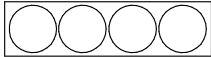
Small
hammer

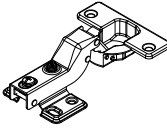

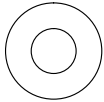
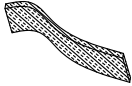
Eye protection
(when using a
hammer or glue)

Part	Size	Name	Quantity
A 	8x30mm	Wooden dowel	14
B 	Ø7x30mm	Cam Bolt	11
C 	Ø15x10mm	Cam Lock	11
D 	Ø3.5x12mm	Screw	20
E 	Ø3.5x25mm	Screw	4
F 	Ø4x14mm	Screw	24
G 	Ø4x20mm	Screw	5
H 	Ø5x40mm	Screw	5
I 	Ø3x16mm	Screw	8
J 	Ø 19mm	Sticker	19
K 	14.7x30mm	Support	8
L 	384mm	Handle	2
M 	Ø35mm	Metal Hinge	4
N 	25x12mm	Door Latch	20
O 	1/4x5/8	Washer	2
P 	20x200mm	Wall Anchor	1
Q 	6x18mm	Shelf Support	4

! HARDWARE IS LOCATED INSIDE A CARDBOARD BOX ! CHECK FOR IT BEFORE DISPOSING PACKAGING

Ruler - Use this ruler to help correctly identify the screws



Step 1

Let's get started! Insert Wooden Dowels (A) into Bottom Panel (1), Left Panel (2), Right Panel (4), Top Rail (10) and Shelf Rail (11). Also, attach Cam Bolts (B) to Left Panel (2), Top Panel (3) Right Panel (4) and Shelf (5) using a Phillips screwdriver.

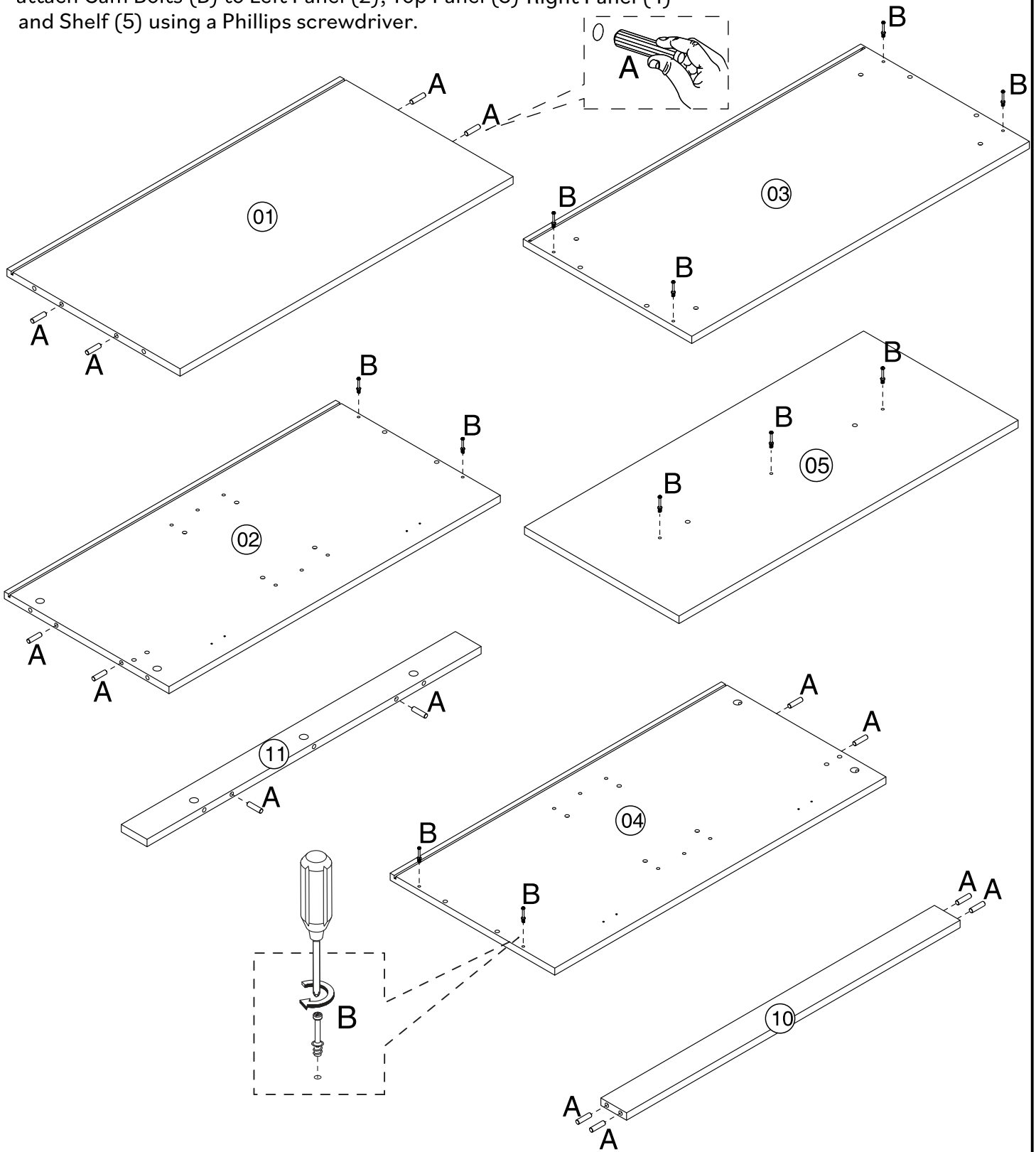

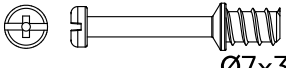
A	 8x30mm 14	B	 Ø7x30mm 11
---	--	---	--

Step 2

Attach Hinges (M) to Doors (8) using Screw (F) and a Phillips screwdriver.
 Insert Glass Door Front (9) in Doors (8) and secure using Door Latch (N), Screw (D) and a Phillips screwdriver.

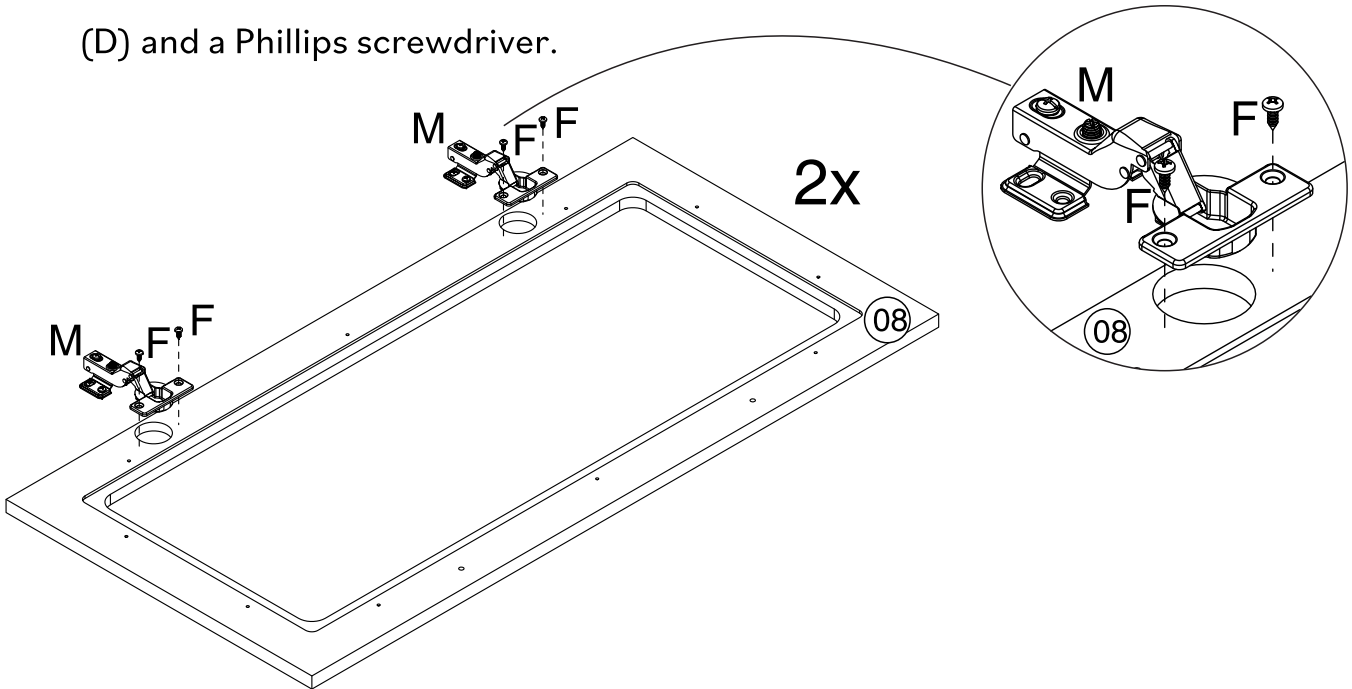

F		Ø4x14mm	8
---	---	---------	---

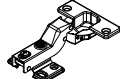
M		Ø35mm	4
---	---	-------	---

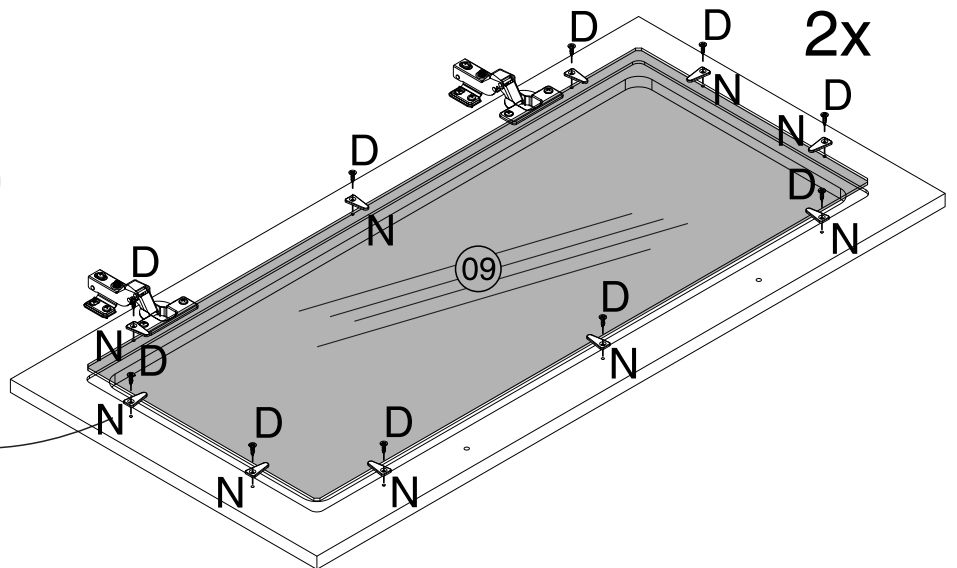
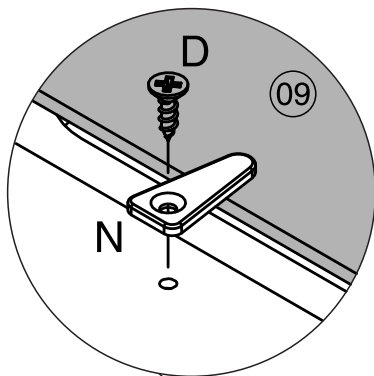

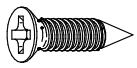

D		Ø3.5x12mm	20
---	---	-----------	----

N		25x12mm	20
---	---	---------	----

Step 3

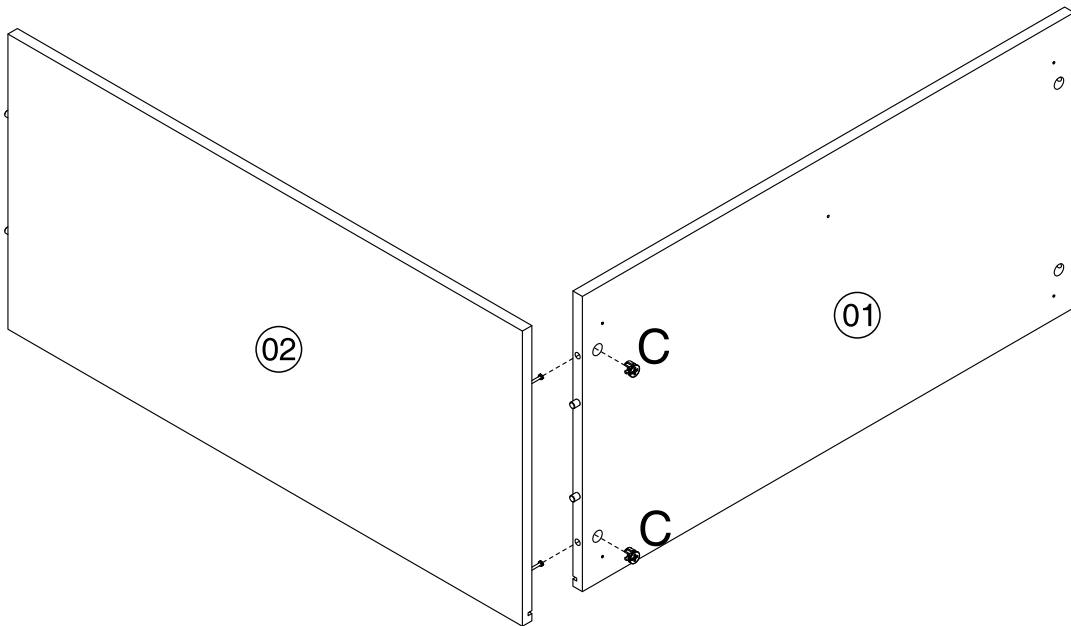
Join Bottom Panel (1) and Left Panel (2) using Cam Locks (C) and a Phillips screwdriver.



C			Ø15x10mm	2
---	---	---	----------	---

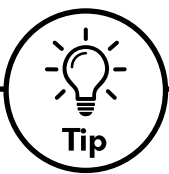

Tip

Cam Locks

Cam Locks help to securely join two pieces together.
Follow these easy steps.

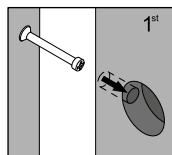

1: Insert Cam Bolt into bolt holes on the flat side. Don't over tighten!

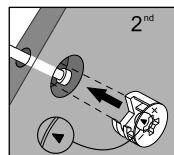

2: Assemble both parts together. The cam bolts go in the drill holes that have a circular hole on the side, you should be able to see the cam bolts through it. After fitting parts together insert the cam lock on the side holes.

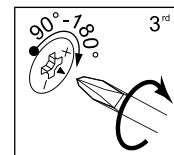

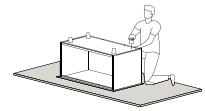

3: On the back of the Cam Lock will be a "C" shape. Insert the Cam Lock so the opening of the "C" fits over the Cam Bolt. Tighten with

Step 4

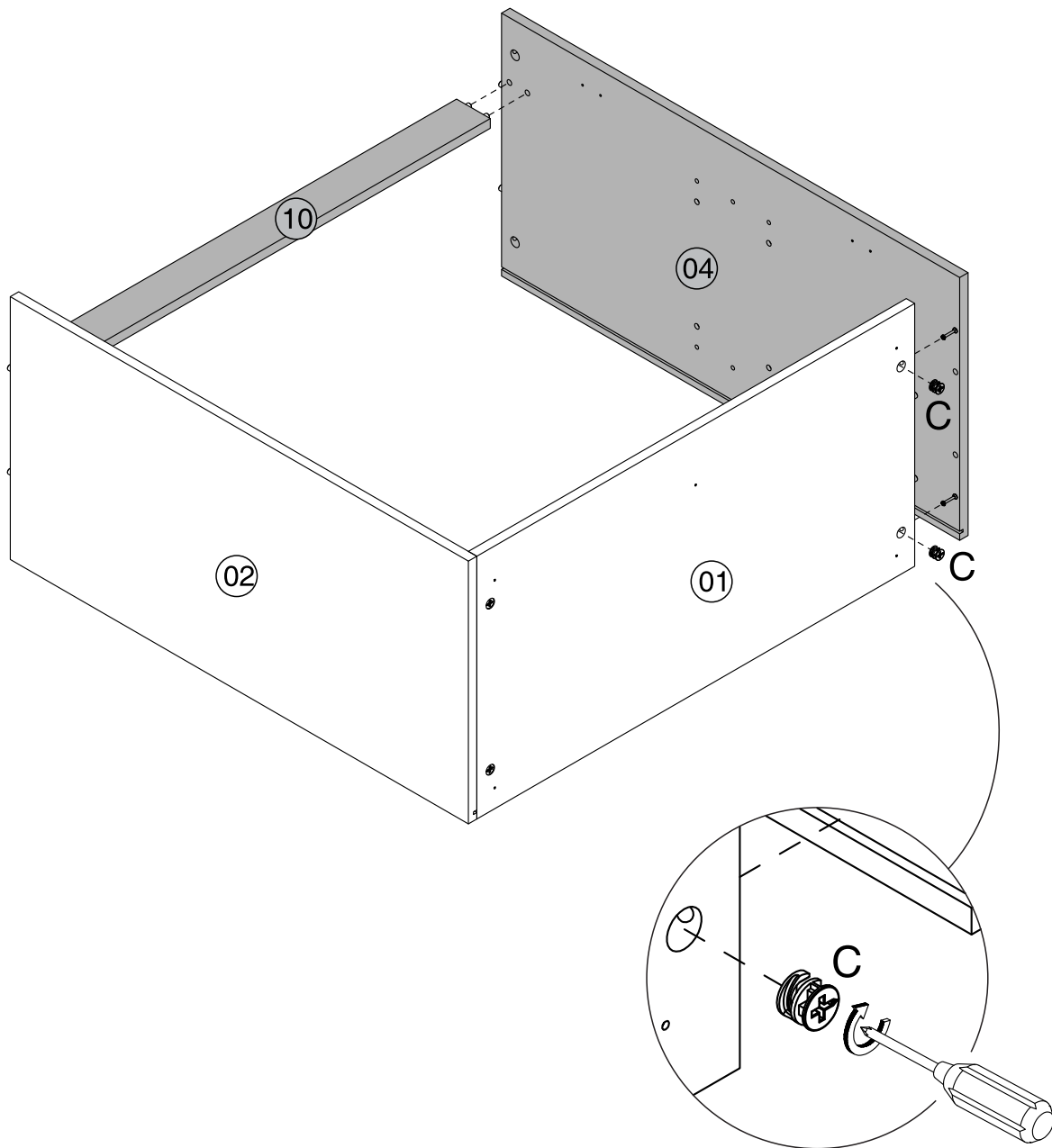

Secure Top Rail (10) and Right Panel (4) using dowels, Cam Locks (C) and a Phillips screwdriver.



C			Ø15x10mm	2
---	---	---	----------	---

Step 5

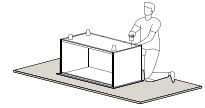

Slide Back Panel (6) between the grooves on Left Panel (2) and Right Panel (4) fitting in Bottom Panel (1).

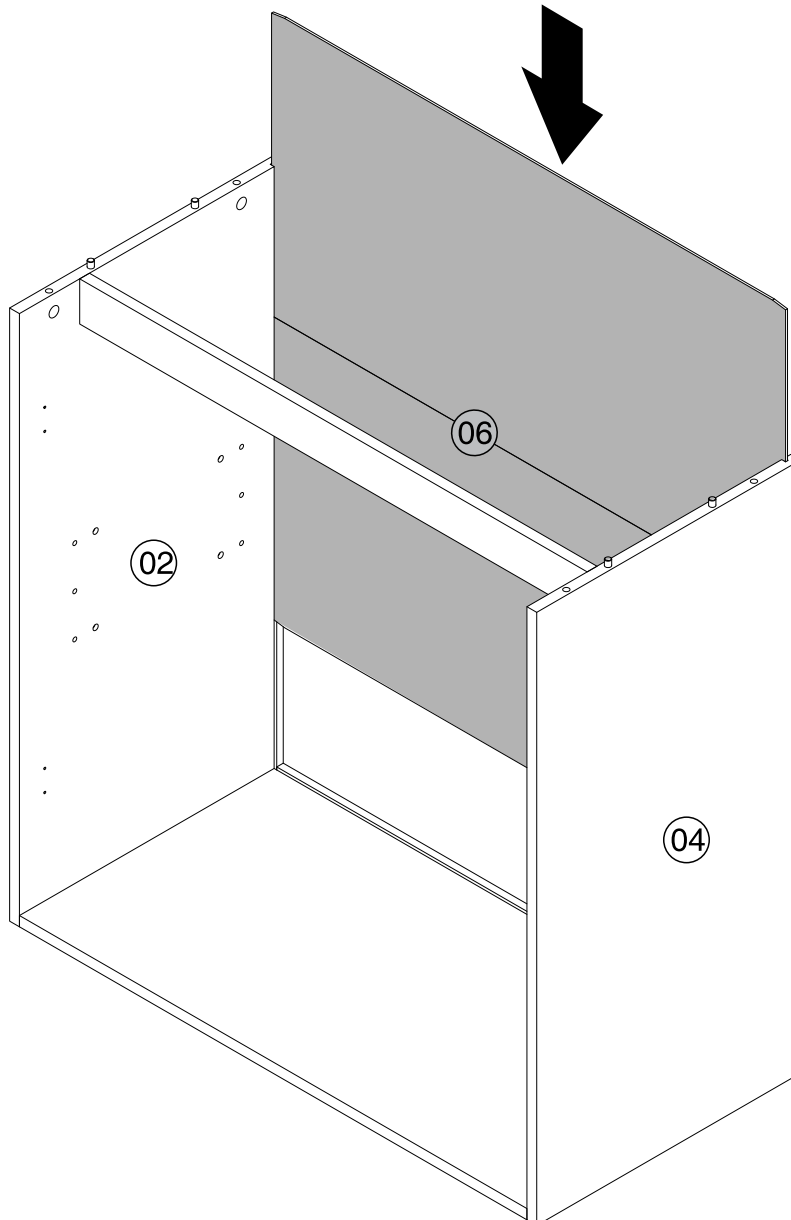
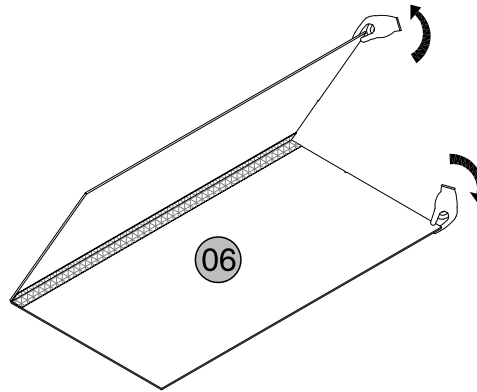

Step 6

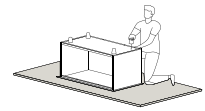

Attach Top Panel (3) to Left Panel (2) and Right Panel (4) using Cam Locks (C) and a Phillips screwdriver.

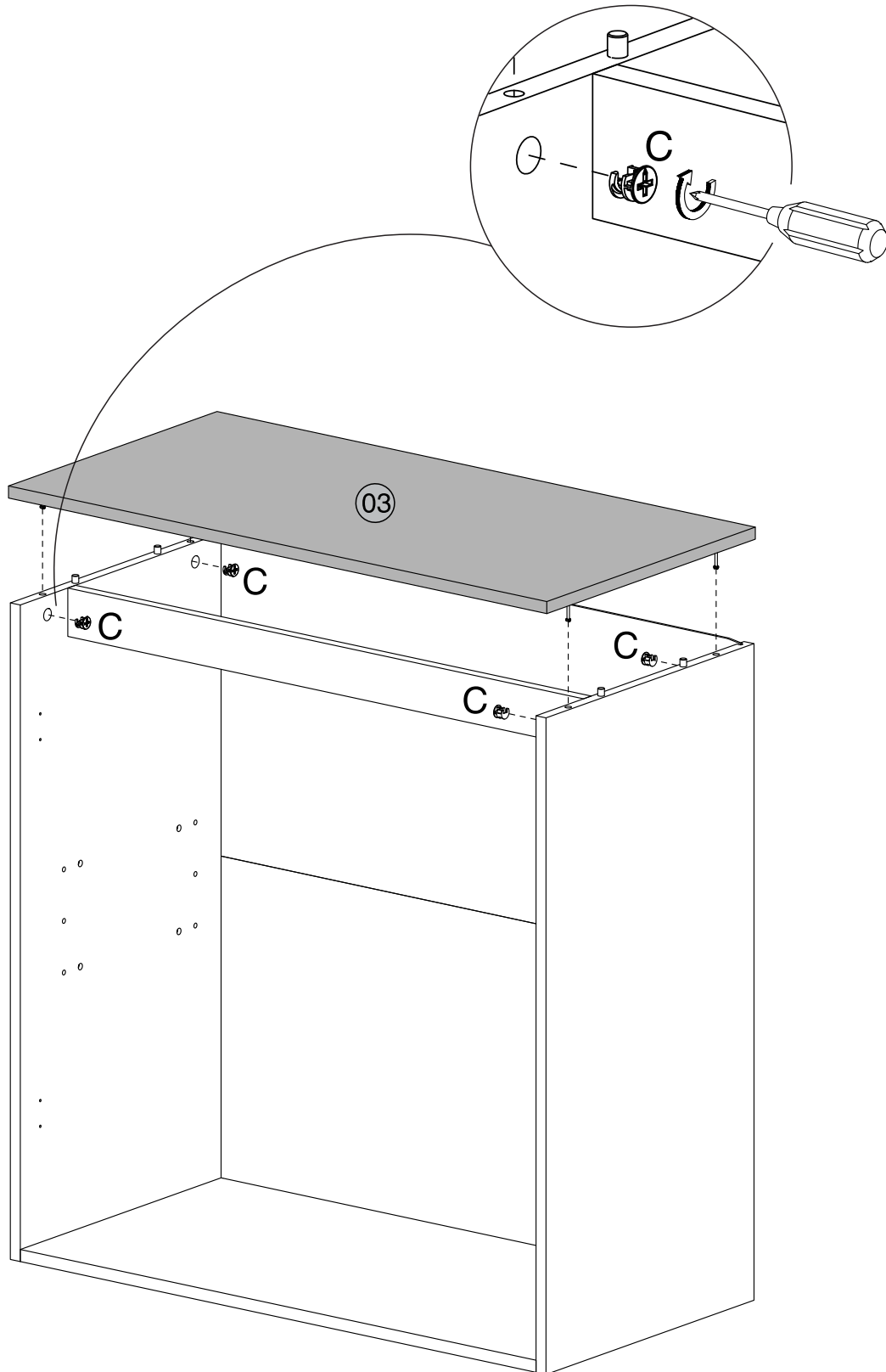

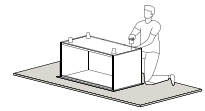

C			Ø15x10mm	4
---	--	--	----------	---

Step 7

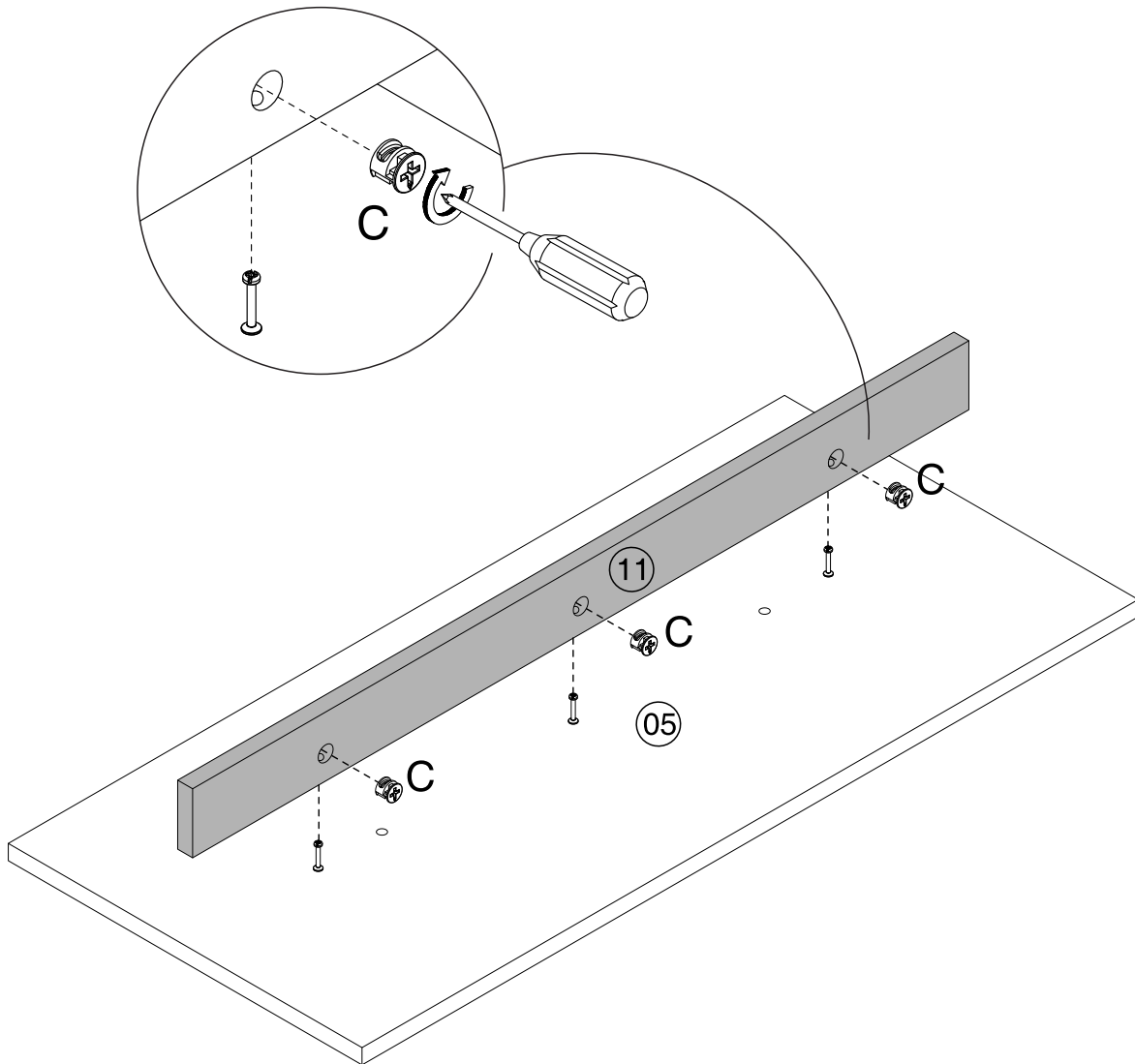

Secure Shelf Rail (11) to Shelf (5) using Cam Locks (C) and a Phillips screwdriver.



C			Ø15x10mm	3
---	---	---	----------	---

Step 8

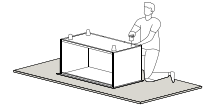

Insert Shelf Support (Q) on the holes in the middle of Side Panels. Then, place Shelf (5).

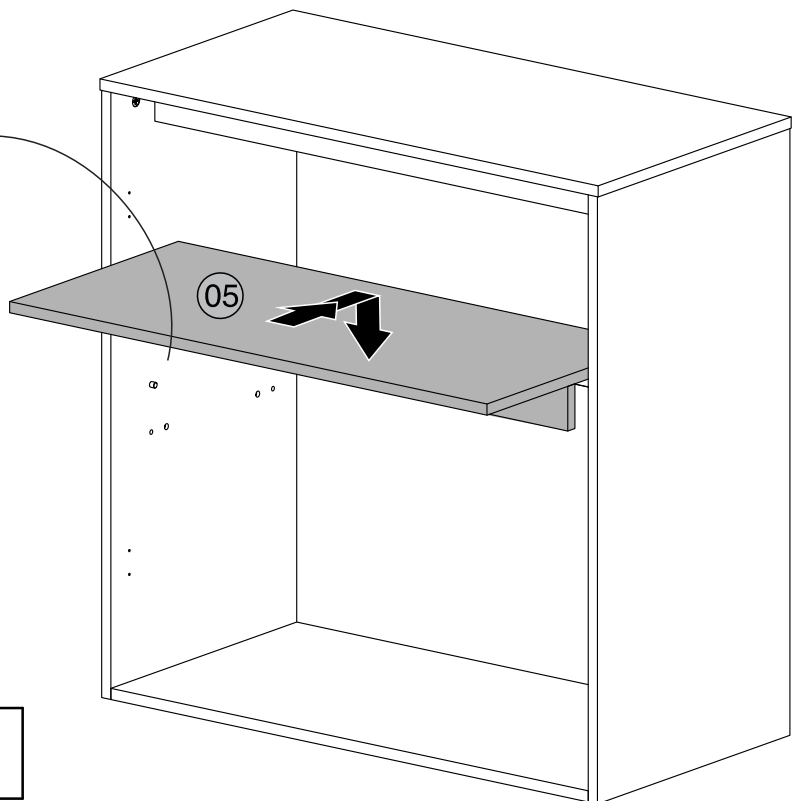
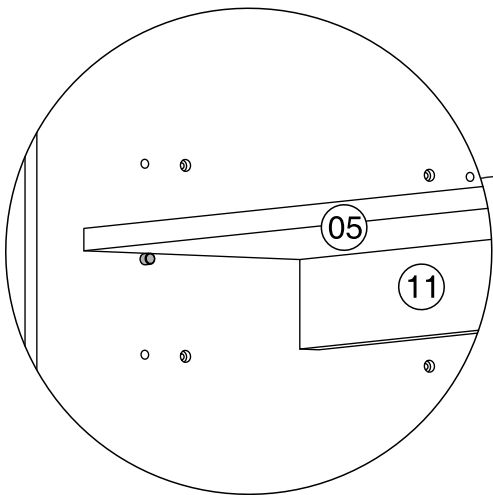
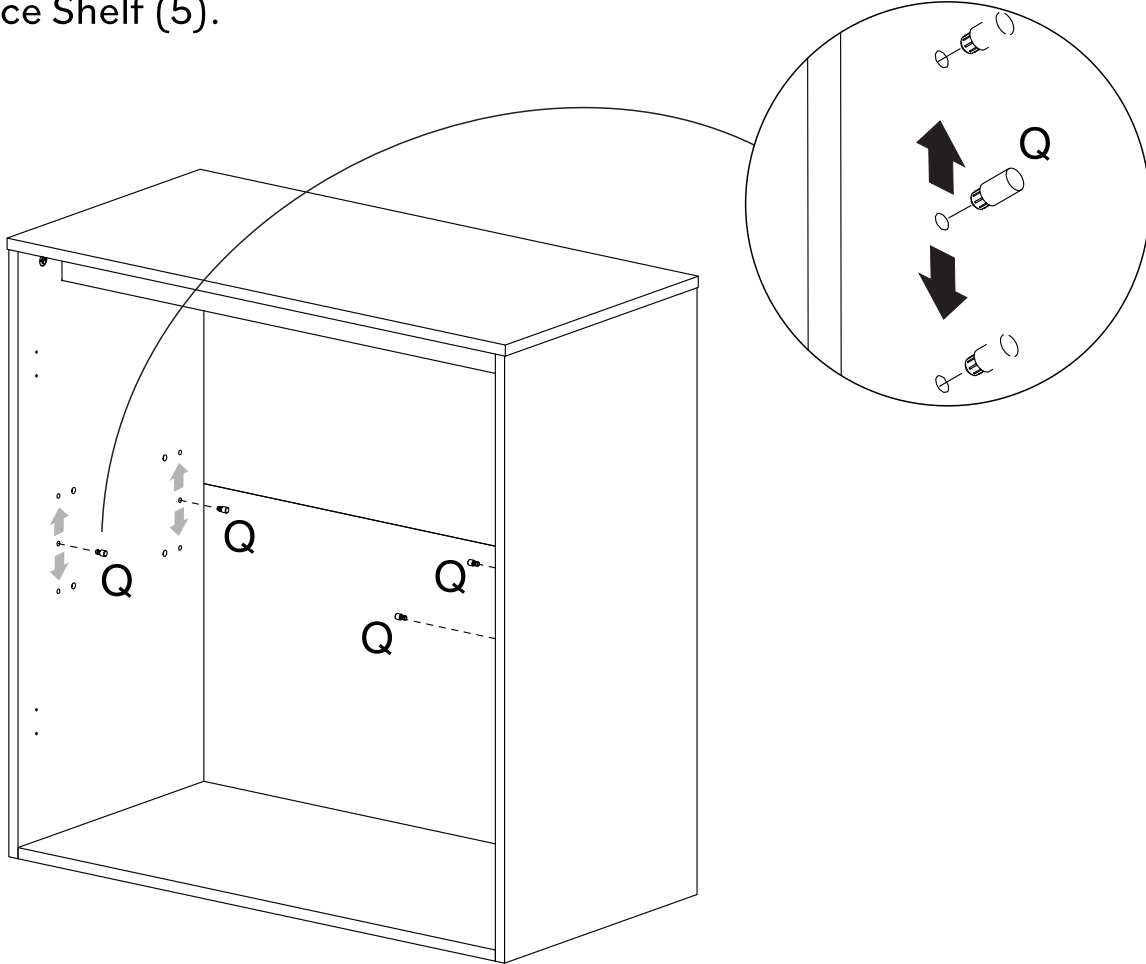

Q		6x18mm	4
---	--	--------	---

Step 9

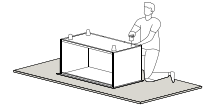

Attach Door (8) on Left Panel (2) using Screws (F) and a Phillips screwdriver.

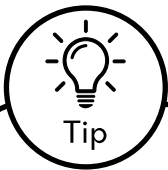
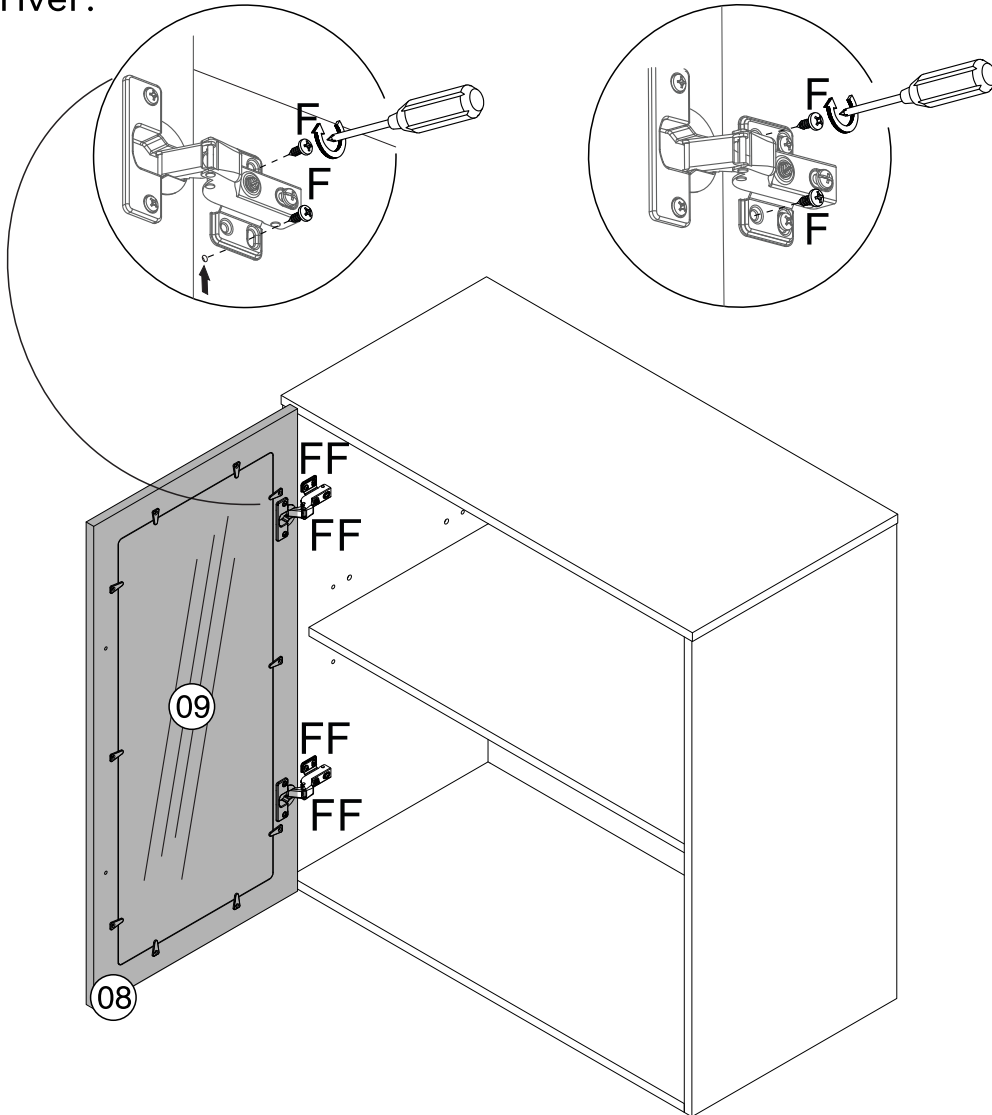

F		Ø4x14mm	8
---	--	---------	---

Adjusting The Cabinet Doors

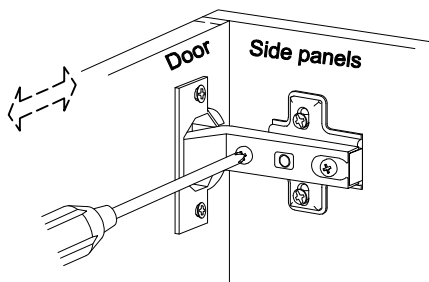

Adjust horizontal width with this screw

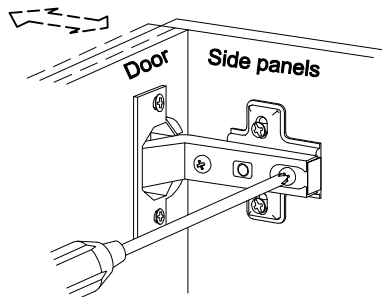

Adjust depth position by loosening the hinge arm mounting screw

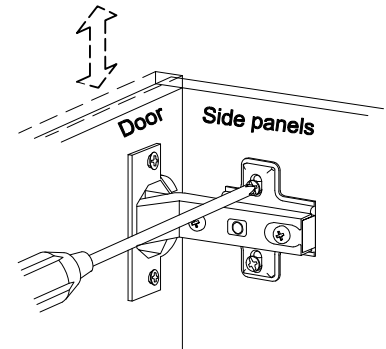

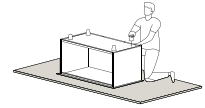

Adjust vertical height via the screws in the mounting plate

Step 10

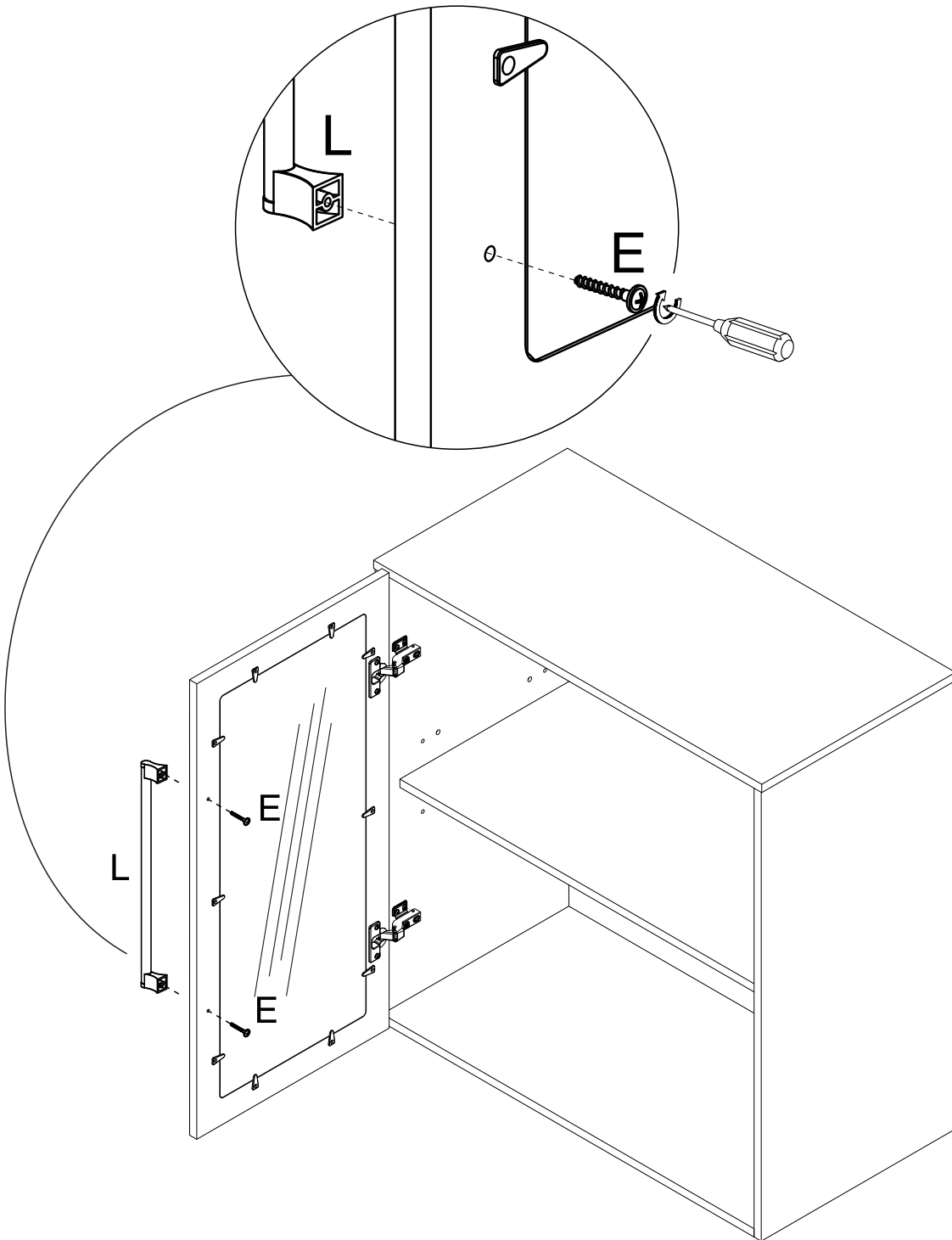

Secure Handle (L) using Screw (E) and a Phillips screwdriver.



E		Ø3.5x25mm	2
---	---	-----------	---

L		384mm	1
---	--	-------	---

Step 11

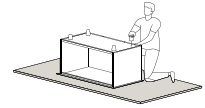

Attach Door (9) on Right Panel (4) using Screws (F) and a Phillips screwdriver.

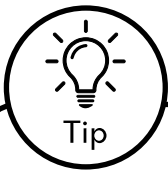
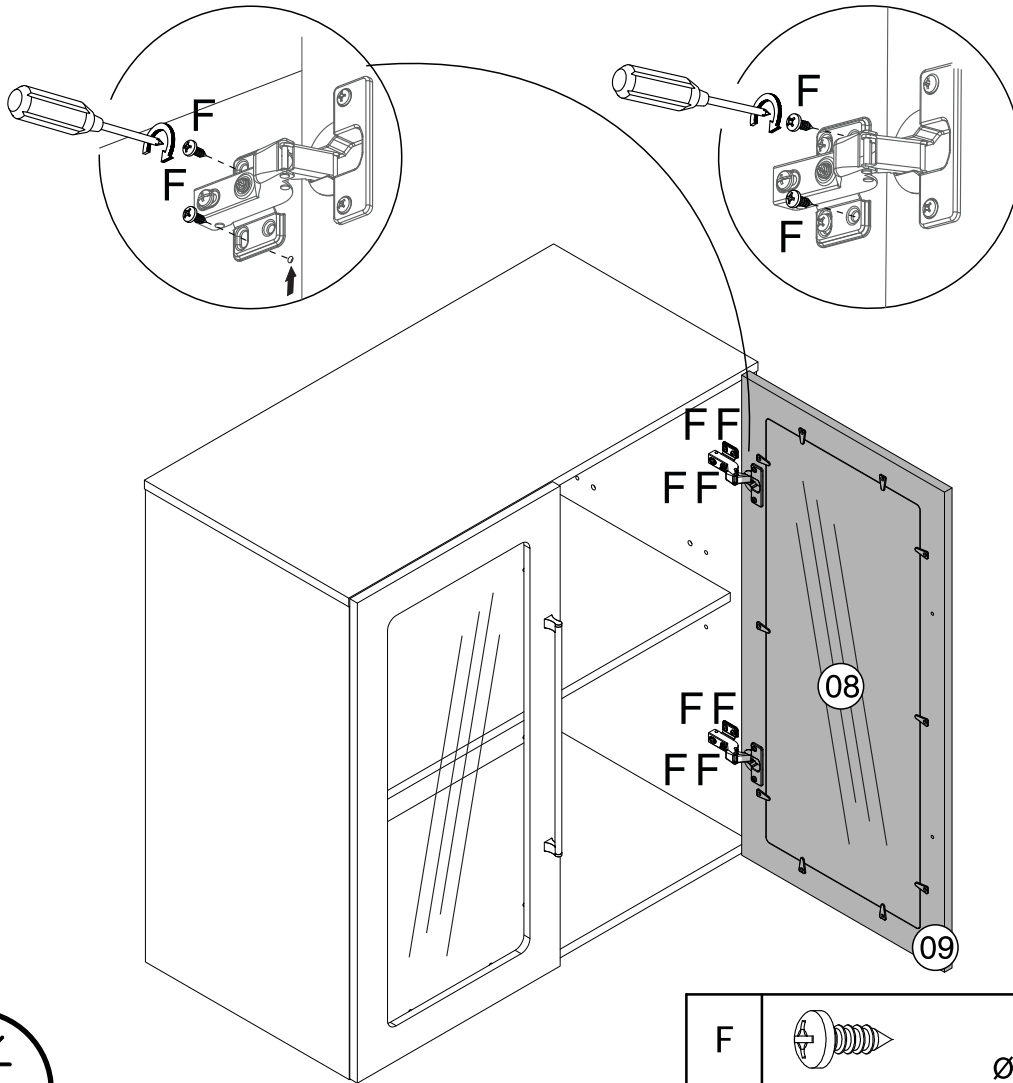

Tip

Adjusting The Cabinet Doors

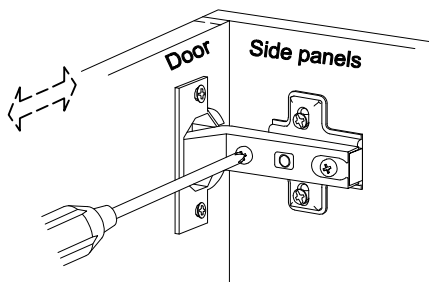

Adjust horizontal width with this screw

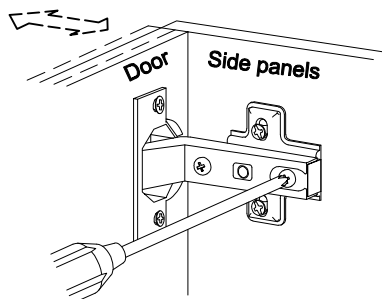

Adjust depth position by loosening the hinge arm mounting screw

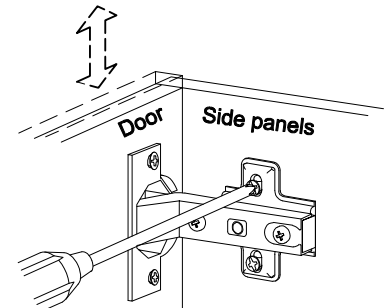

Adjust vertical height via the screws in the mounting plate

Step 12

Secure Handle (L) using Screw (E) and a Phillips screwdriver.

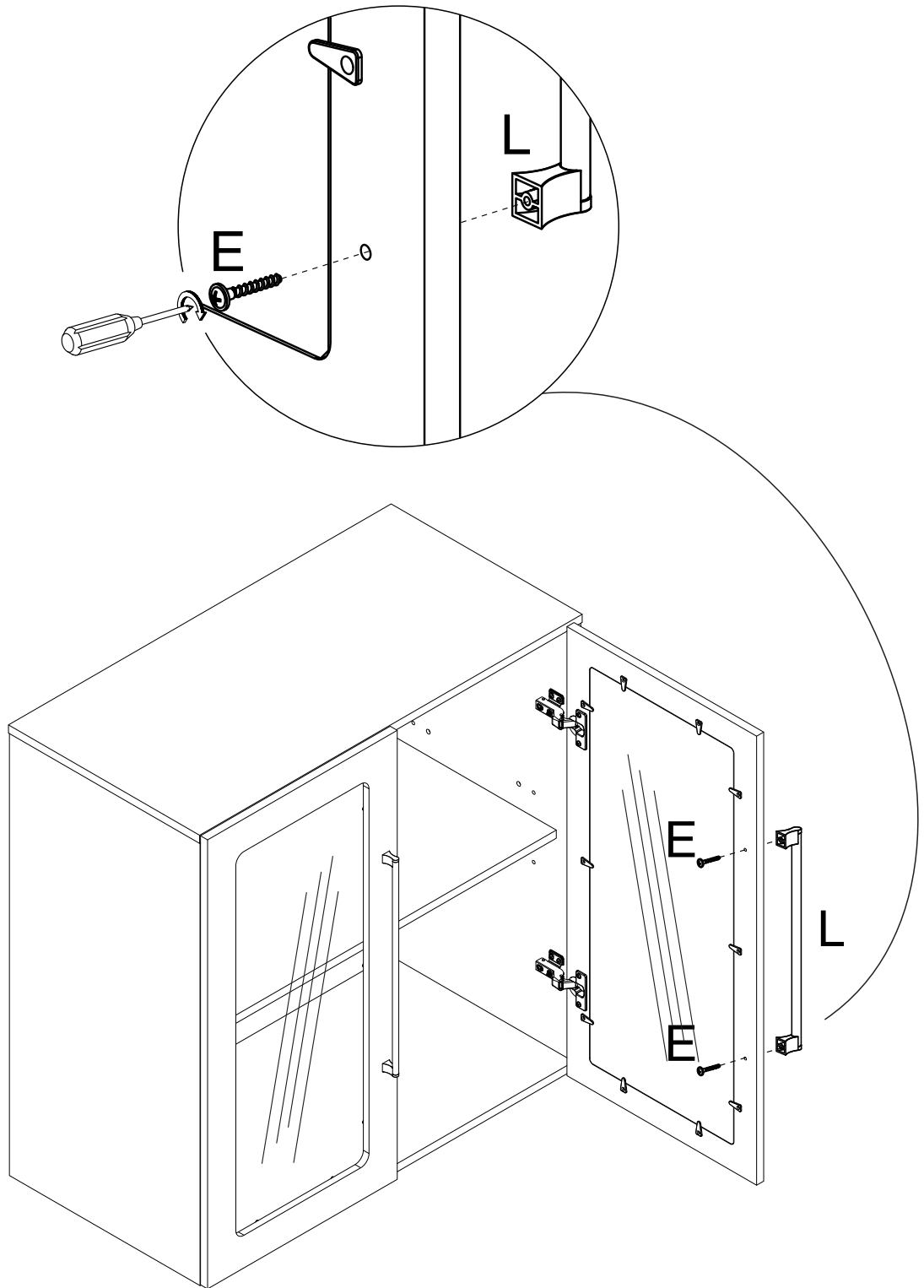

E		Ø3.5x25mm	2
---	--	-----------	---

L		384mm	1
---	--	-------	---

Step 13

Secure Back Panel (6) using Support (K), Screw (I) and a Phillips screwdriver.

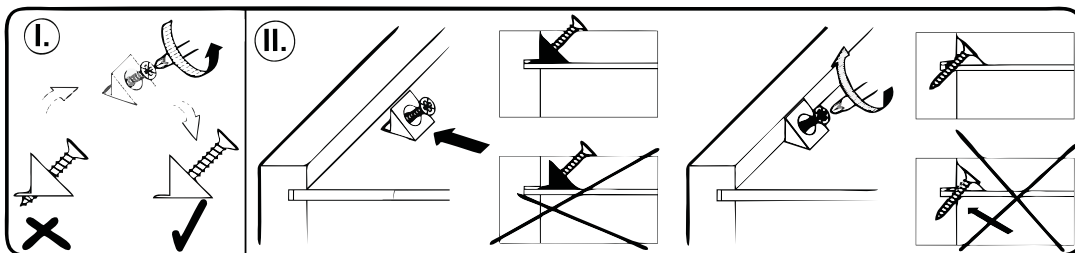
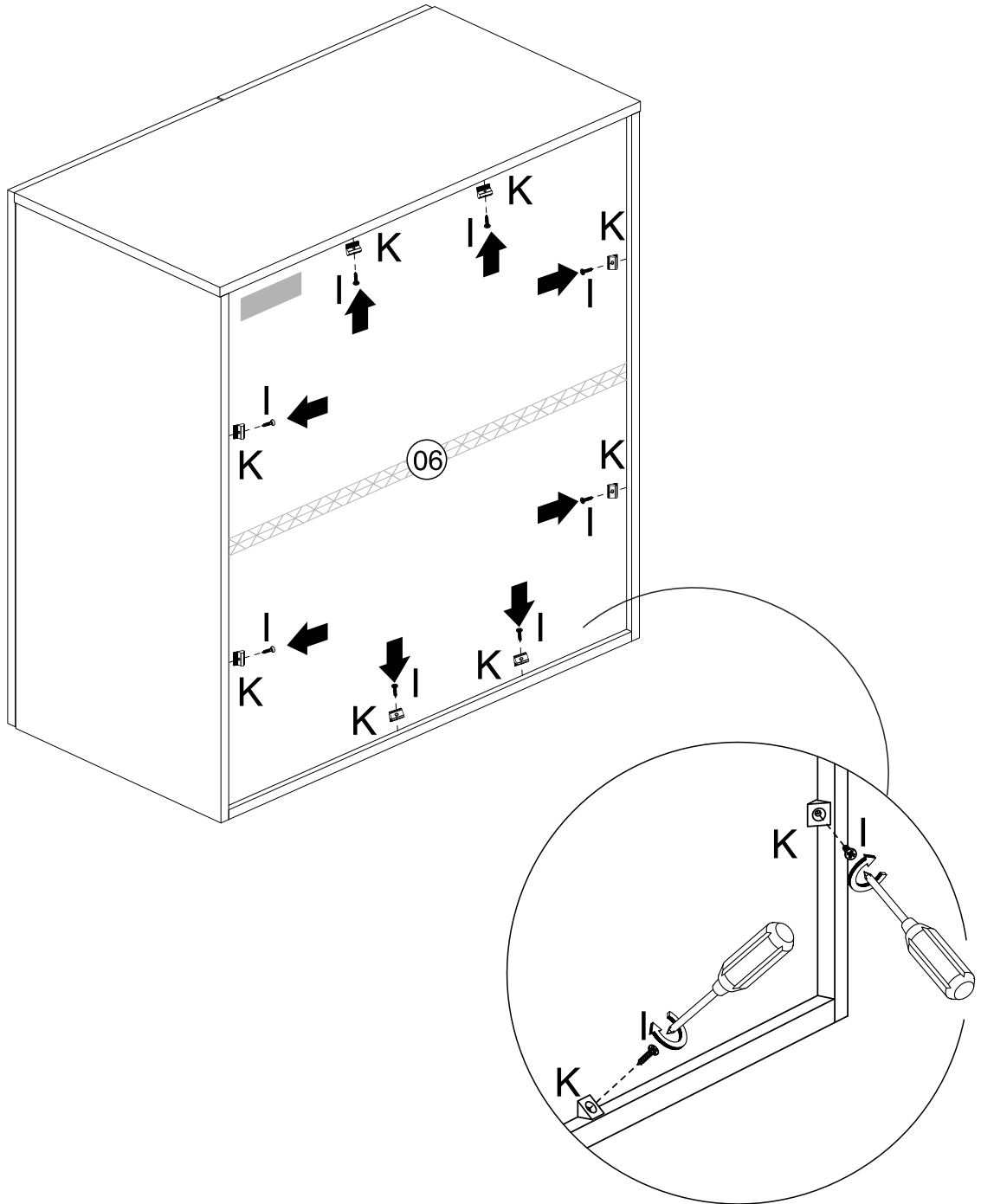

I		Ø3x16mm	8
---	--	---------	---

K		14.7x30mm	8
---	--	-----------	---

Step 14

If you are not using your new cabinet on top of another Modular Mia Cabinet, you can attach Feet (7) using Screw (H) and a Phillips screwdriver.

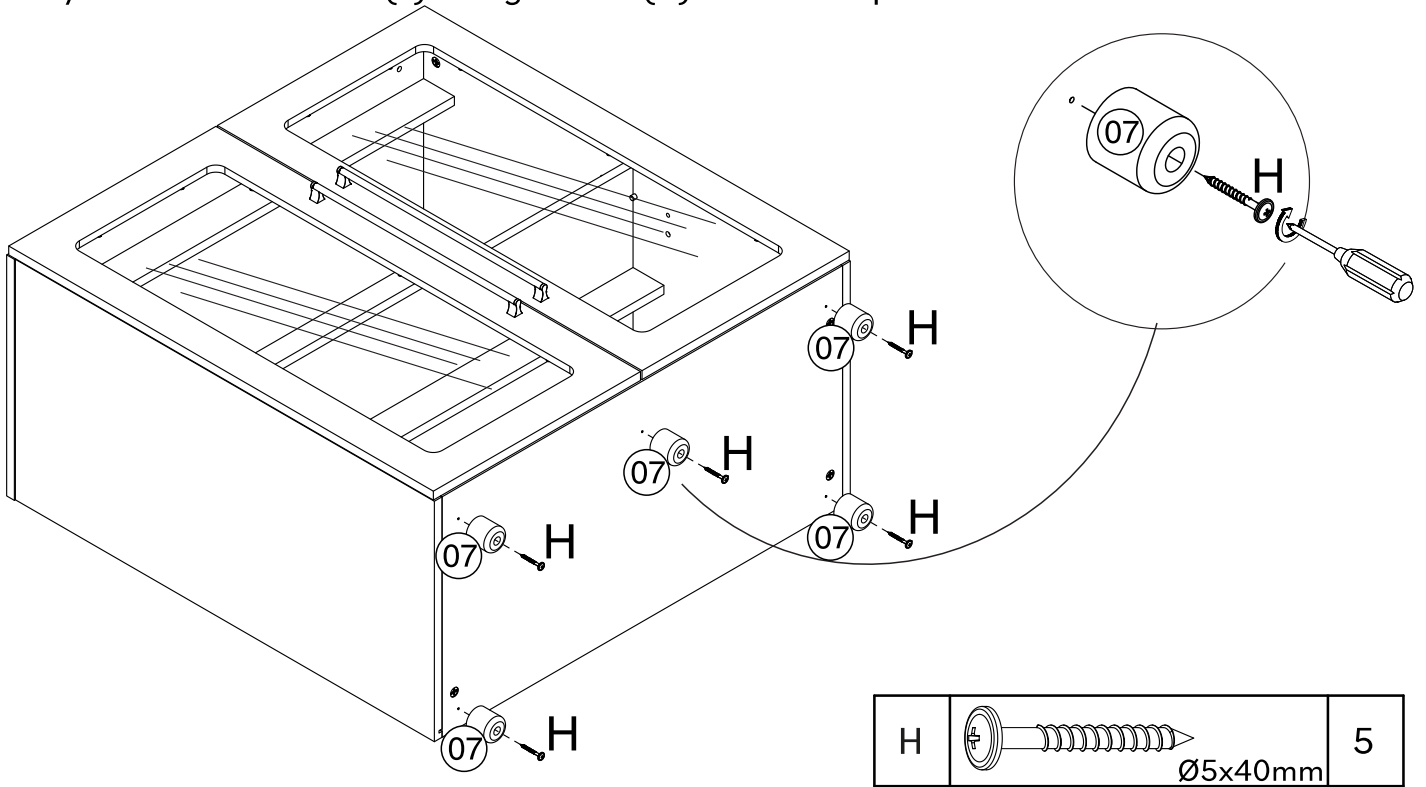

Modular Assembly Options

Step 15

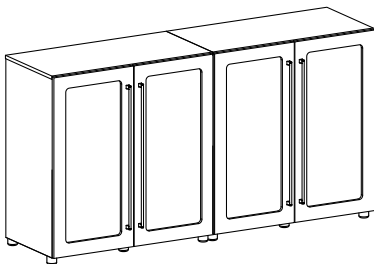

Step 16

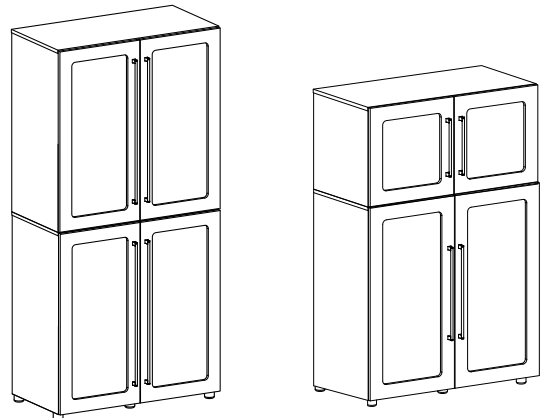

Step 15

Attach your cabinets side by side using Screws (G) and a Phillips screwdriver. The holes as pre drilled.

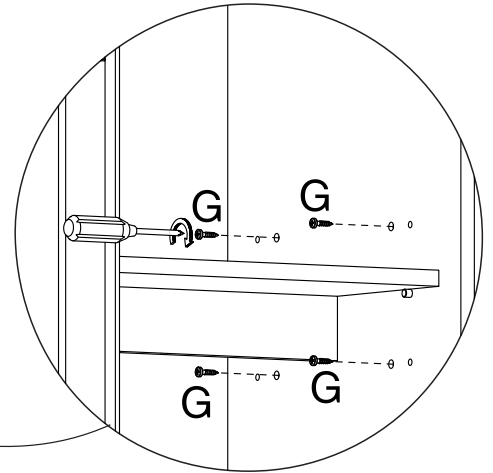
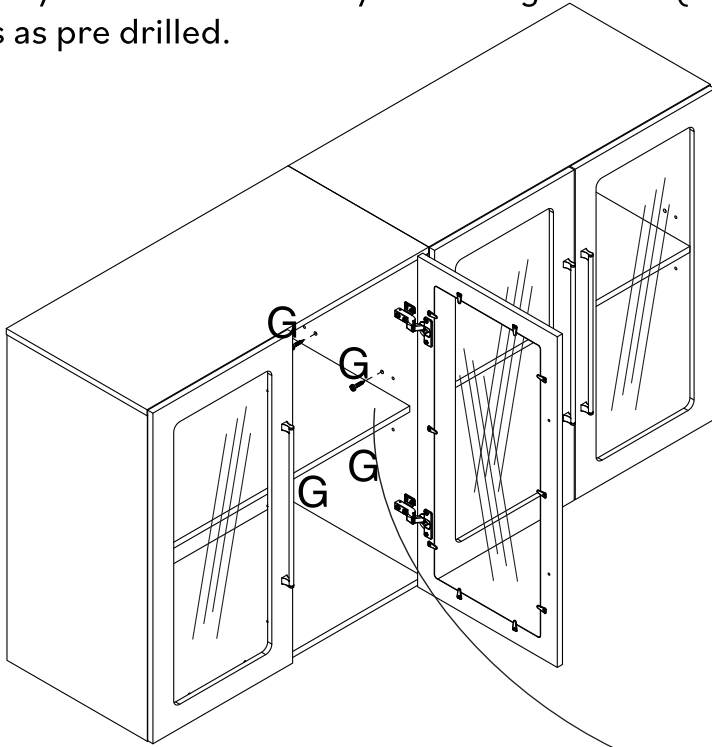

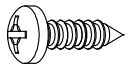
G		Ø4x20mm	4
---	--	---------	---

Step 16

If assembling your cabinets on top of each other, use Screws (G) and a Phillips screwdriver to join them through the top and bottom panels. The holes are predrilled

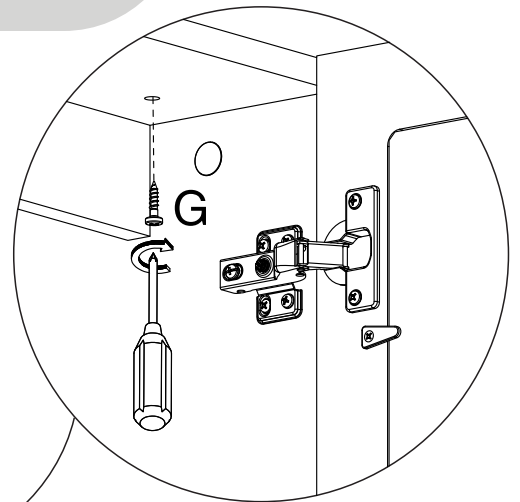
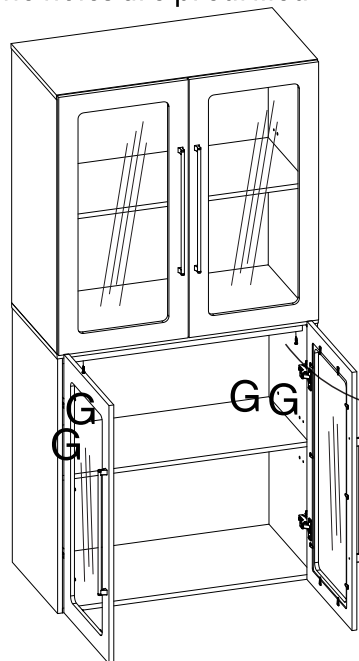

Assembly Option

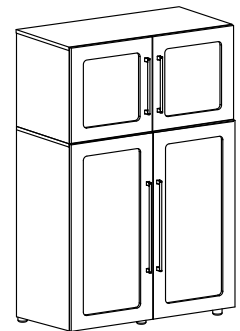

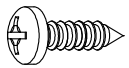
G		Ø4x20mm	4
---	---	---------	---

Step 17

With everything in place use Stickers (J) to cover the extra holes.

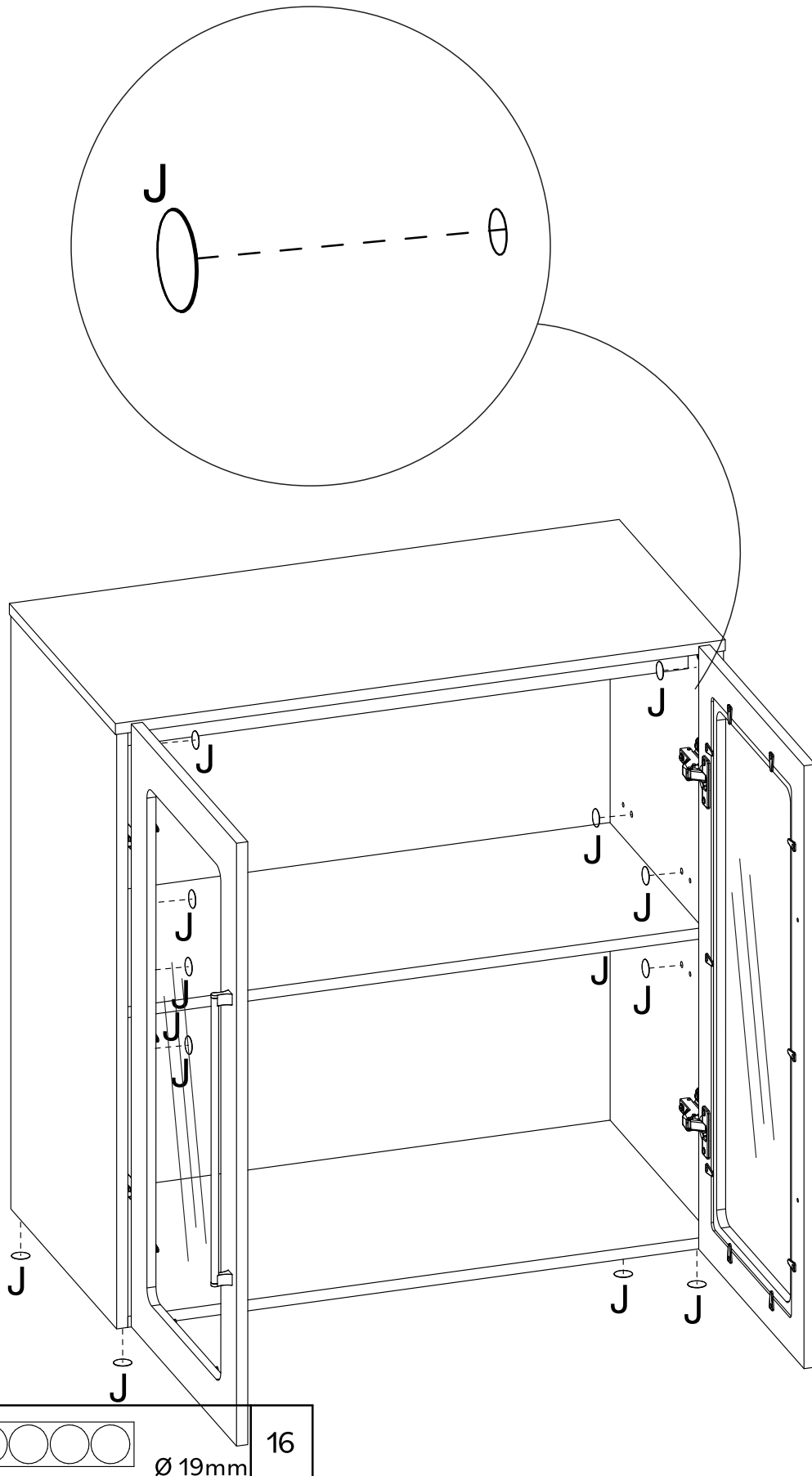

Step 18

Attach your Cabinet to the wall. Secure Wall Anchor (P) to your cabinet using Washer (O), Screw (G) and a Phillips screwdriver.

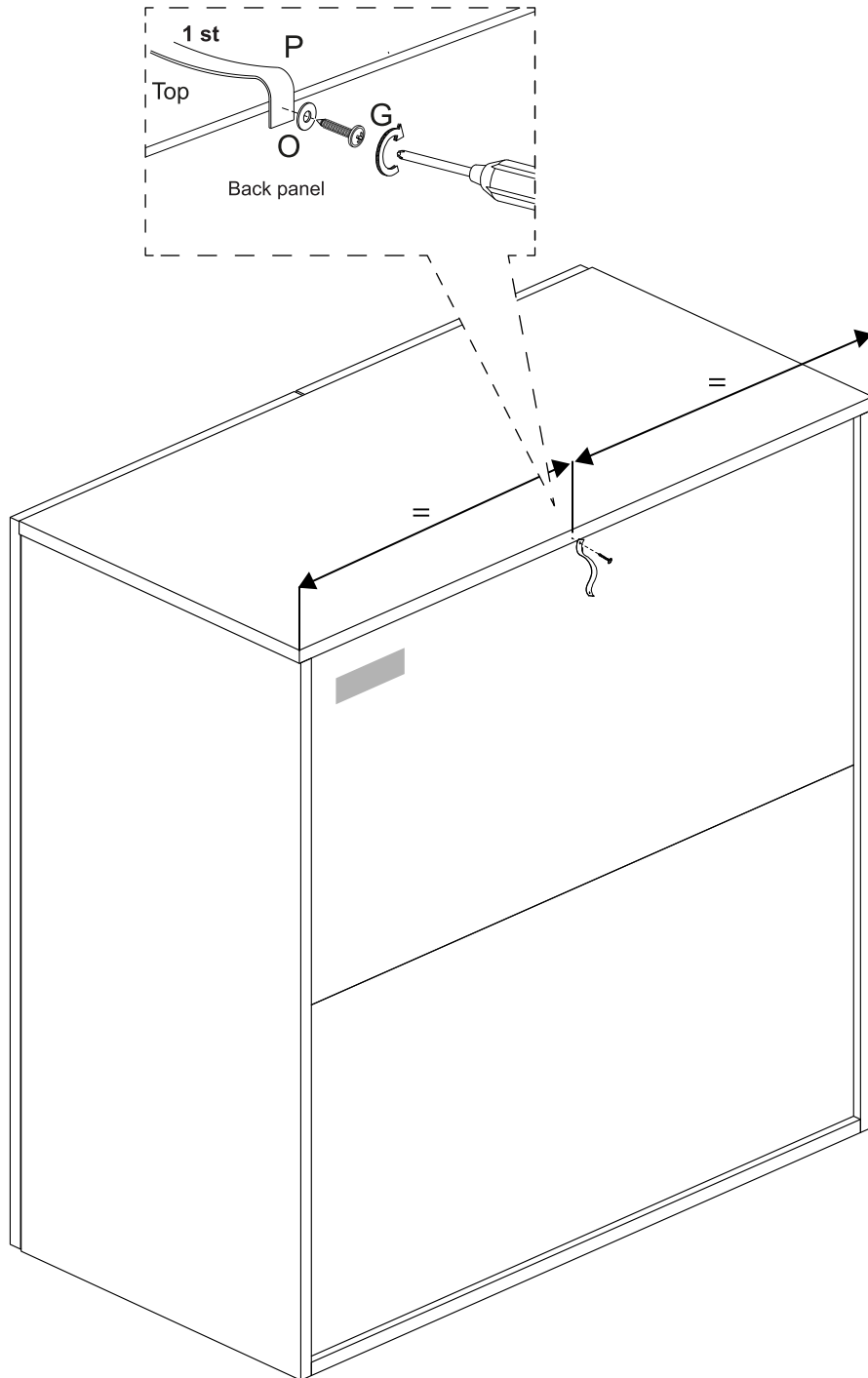

G		Ø4x20mm	1
---	--	---------	---

O		1/4x5/8	1
---	--	---------	---

P		20x200mm	1
---	--	----------	---

Step 19

To finish this up use a plastic bush suitable for your wall. Then, secure the Wall anchor (P) to the wall using Washer (O) and a screw also suitable for your wall.

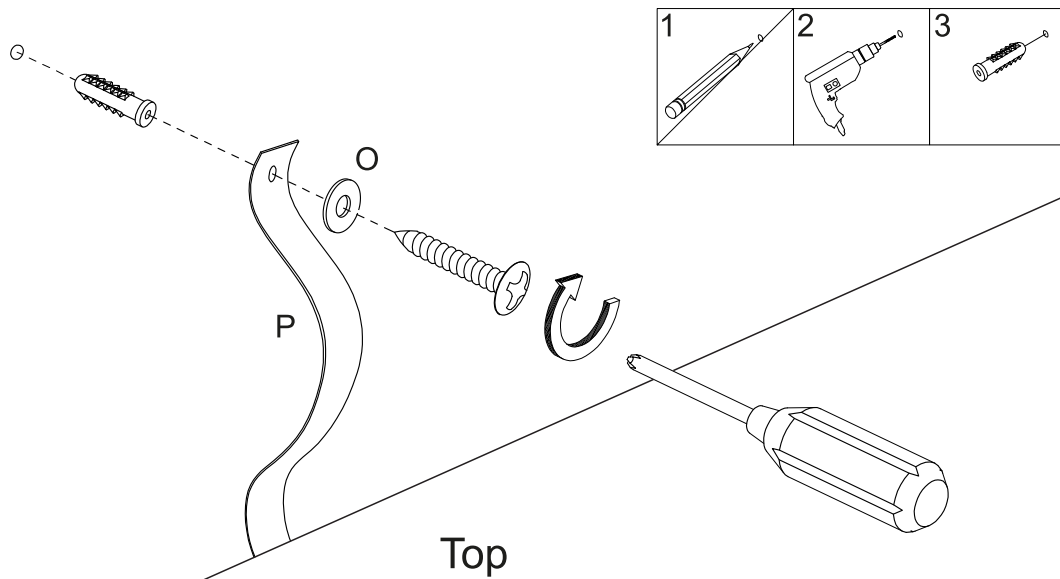

O		1/4x5/8	1
---	---	---------	---

Warning

Serious or fatal injuries can occur from furniture tipping over. To prevent the furniture from tipping over we recommend that it is permanently fixed to the wall. Wall anchor and hardware are included with this product. Please make sure hardware is suitable for your walls before installing, as different wall materials may require different types of anchors.

You did it! Enjoy your new Modular Cabinet!

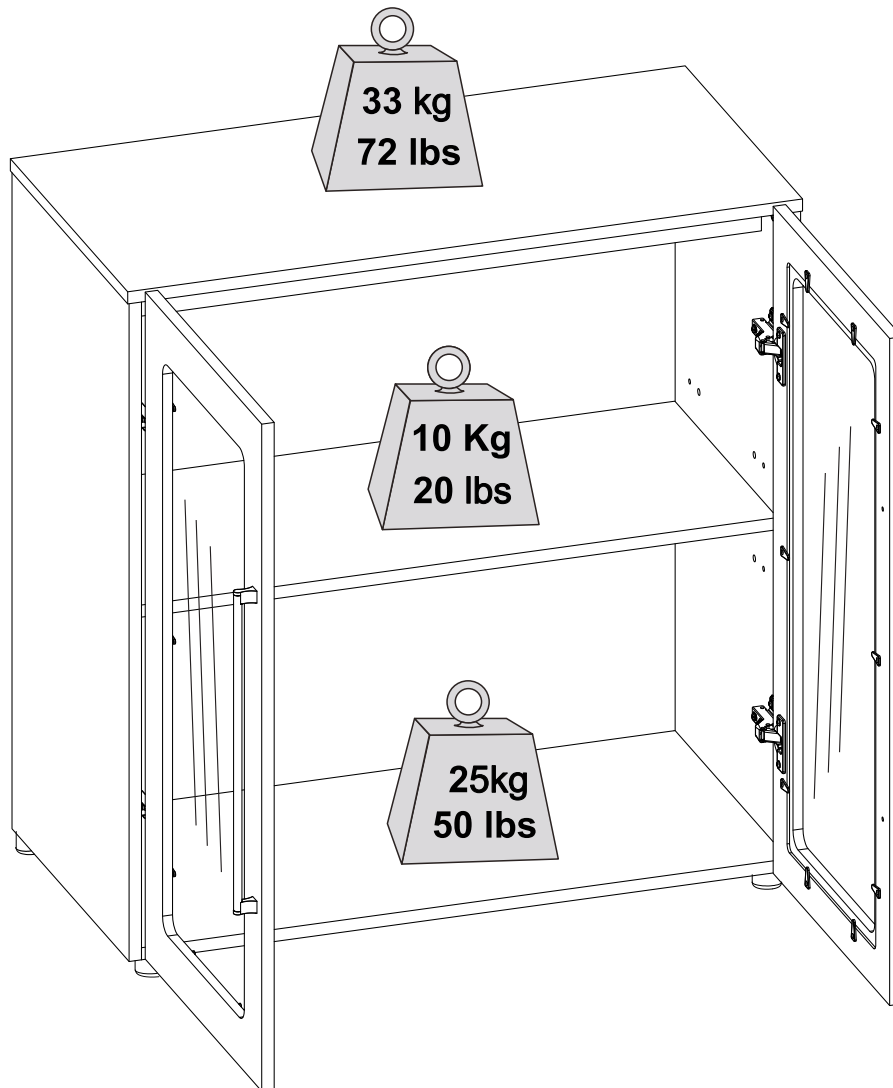

Congratulations on your new piece of furniture!

We would love to hear about it and see it.